



Leigh VRS Vacuum & Router Support for Leigh Dovetail Jigs

Installation & Setup Guide

- VRSD24*** fits D4R Pro, D4R & D4 Jigs, and 24" (610mm) D3, D1258R and D1258 Jigs
- VRS24*** fits the Super24 Jig
- VRS18** fits the Super18 Jig
- VRS12** fits the Super12 Jig
- VRS16** fits the D1600 Jig

*VRSD24 & VRS24 parts are not interchangeable

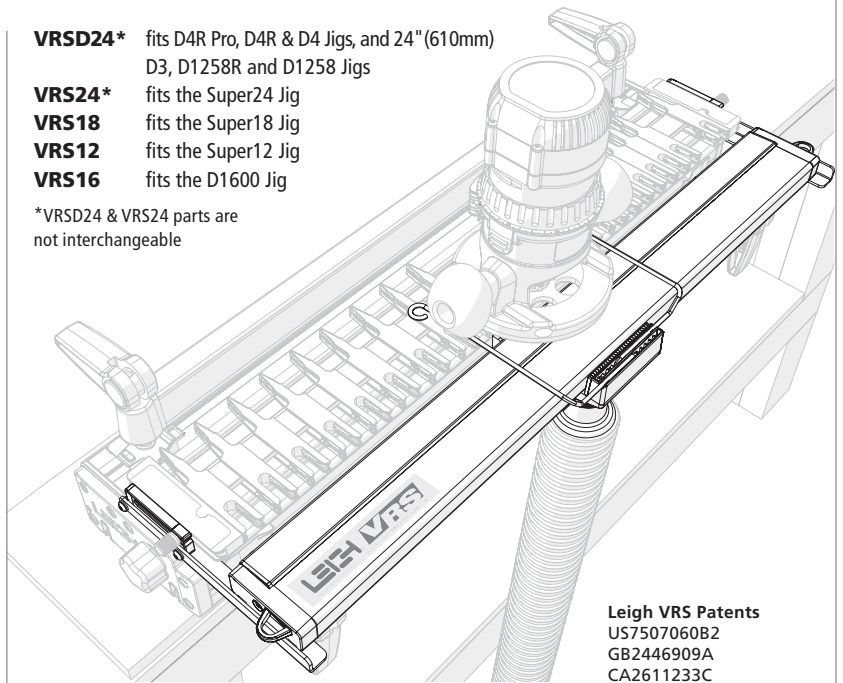

Leigh VRS Patents
US7507060B2
GB2446909A
CA2611233C

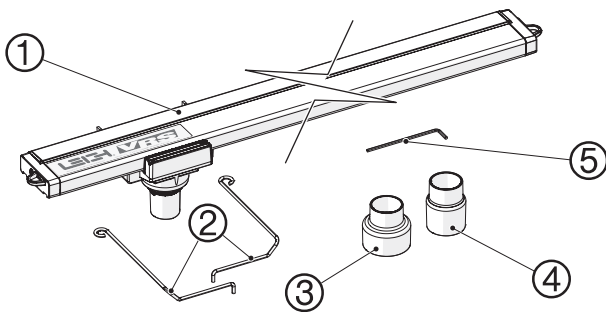

1 WHAT'S IN THE BOX All VRS models include:

- ① One extruded aluminum body and ABS collector
- ② One pair of router follower rails
- ③ One large hose adaptor
- ④ One small hose adaptor
- ⑤ One hex key

Plus, parts in Steps 2, 3, or 4, depending on your model.

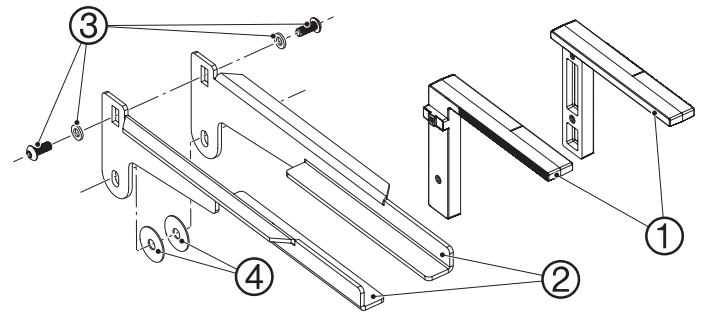

2 VRSD24 for D4R Pro, D4R, D4 and 24" (610mm) D3, D1258R and D1258

- ① One pair short finger assembly support brackets
- ② One pair of steel VRS brackets (Black)
- ③ Two mounting screws and washers
- ④ Two nylon washers

The VRSD24 can be used for all dovetailing and box joint & Isoloc joint template routing. It does not work with the M2 or MMTA.

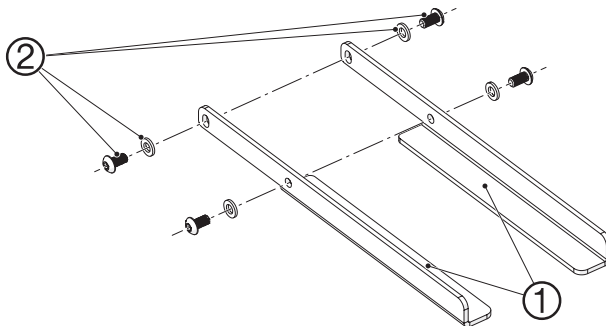

3 VRS12, VRS18, VRS24 for Super12, Super18 & Super24

- ① One pair of steel VRS brackets
- ② Four mounting screws and washers

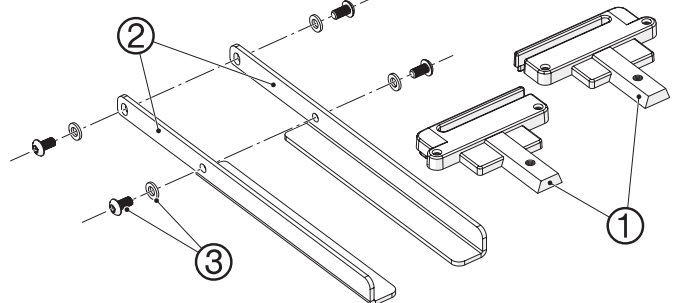

4 VRS16 for the D1600

- ① One pair of modified finger assembly support brackets
- ② One pair of steel VRS brackets
- ③ Four mounting screws and washers

VRS Installation for 24" (610mm) D-Series Jigs

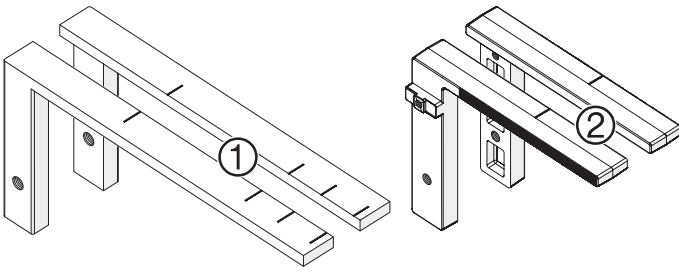

5 D4R Pro, D4R, D4, 24" (610mm) D3, D1258R and D1258 owners With the exception of the D4R Pro, first remove the long support brackets ① from your jig (or short brackets from your D1258/R, not shown). Then, install the **new** short brackets ② included with the VRSD24. **D4R Pro Jig owners: The new brackets are identical to those supplied with your jig. Keep as spares.**

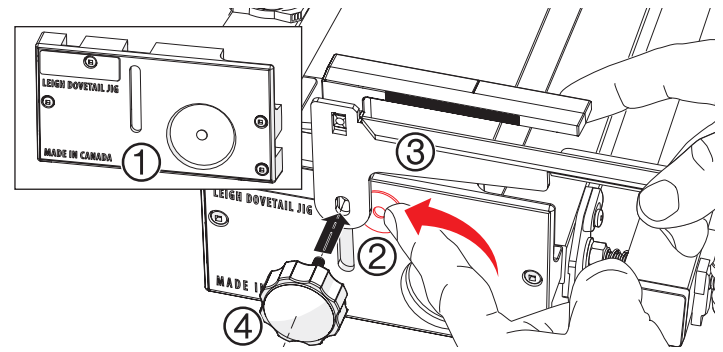

6 If the end housings of your jig look like this ①, slide one of the nylon washers ② between the steel bracket ③ and the end housing, and then thread the bracket knob ④ back in. Repeat this step on the opposite end of the jig.

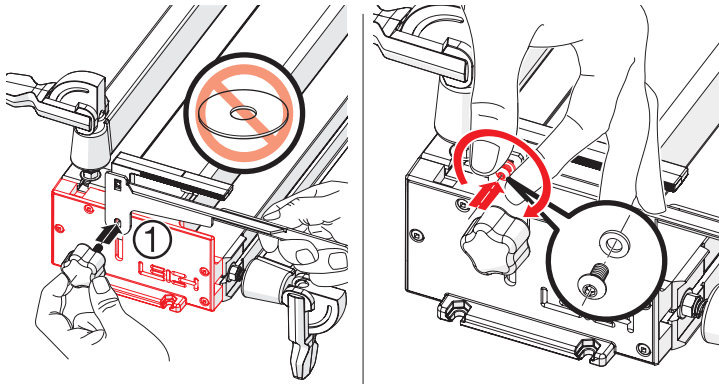

7 If the end housings look like this ①, it's a D4R Pro, D4R or late model D4 jig, and the nylon washers **should not be used**. Install the two 10-24 button head screws and washers, one at each end, finger tight only.

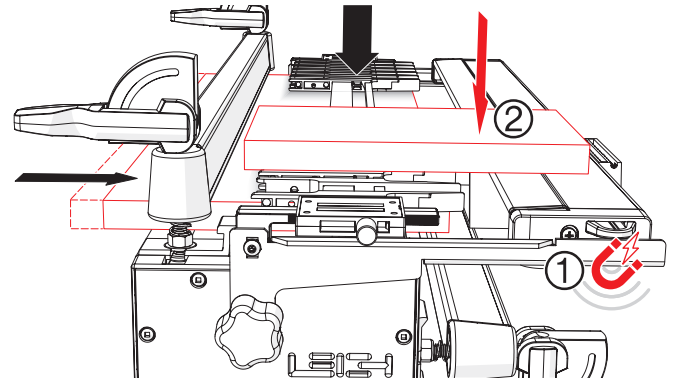

8 Install the spacer board and jig finger assembly on the jig and lower it onto the support board. Install the VRS onto the steel brackets ①. It attaches magnetically. Lay a piece of flat board ② on the finger assembly, extending out over the top of the VRS extrusion.

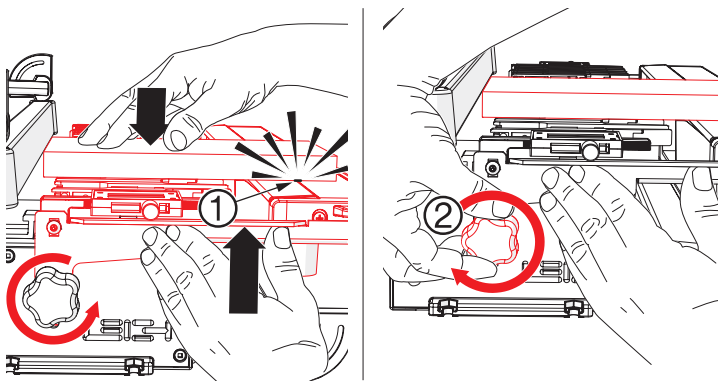

9 Loosen the support bracket knobs and while holding the board down flush on the finger assembly, raise one steel bracket until the **peak** ① on top of the VRS extrusion touches the underside of the board. Now tighten the knob at that end ②. Repeat at other end. **Double-check and readjust both ends as needed until the finger assembly is level with the VRS extrusion peak.**

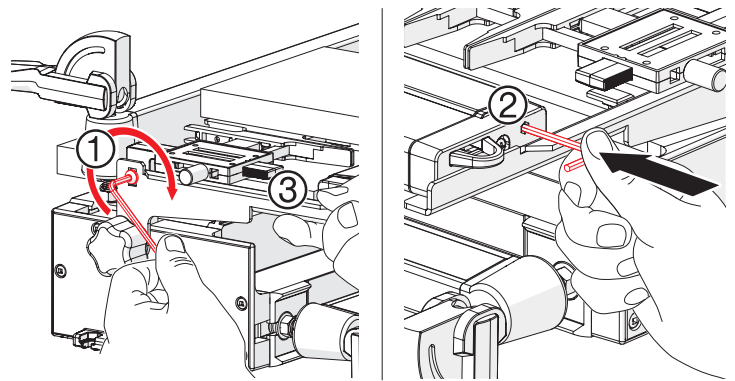

10 Now firmly tighten the two button head screws ①. The hex key stows in the right hand end of the VRS ②. **After installation, when raising and lowering the combined VRS and finger assembly, always take the weight at the inner end of the brackets ③, not at the VRS ends.** Note: The VRS height may need to be reset when using Isoloc or Box Joint Templates.

VRS Installation for Super Jigs and D1600 Jig

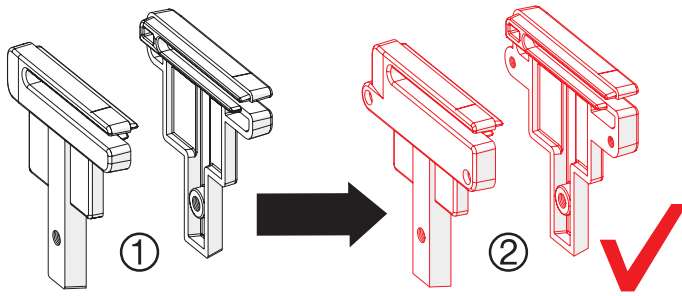
**11 Super Jig and D1600 owners**

Super Jig owners: Your jig already has these new brackets ②.

D1600 owners: Remove the existing cast support brackets ①. Use the new type ② supplied with your VRS16.

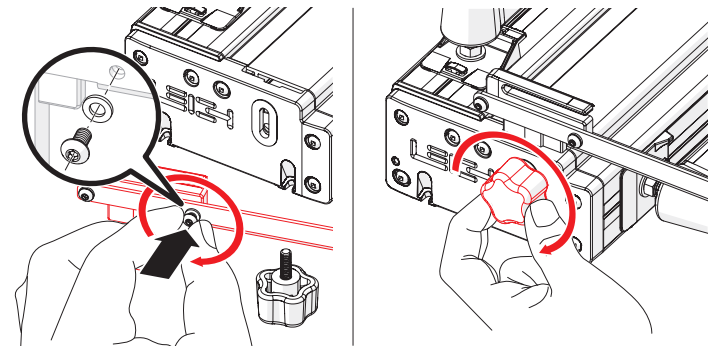

12 Attach the pair of steel VRS support brackets to the cast finger support brackets (with the horizontal surfaces inwards) using the four 10-24 button head screws and washers, **but just finger tighten only**.

Fit the assembled brackets to both ends of the jig.

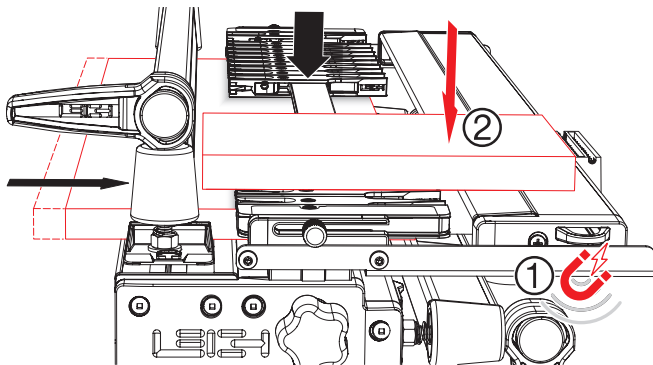

13 Install the spacer board and jig finger assembly on the jig and lower it onto the support board. Install the VRS onto the steel brackets ①. It attaches magnetically. Lay a piece of flat board ② on the finger assembly, extending out over the top of the VRS extrusion.

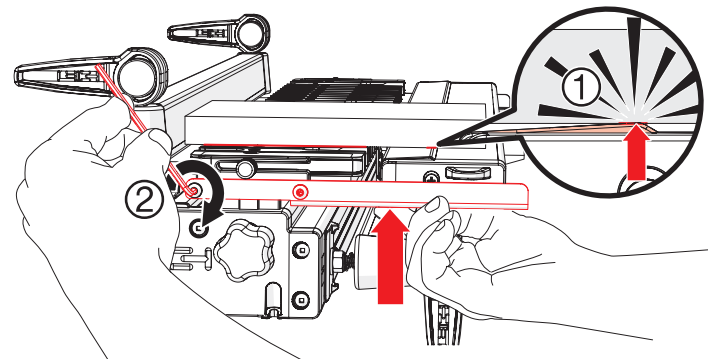

14 Starting on one end, raise one steel bracket until the VRS extrusion's **peak** ① touches the underside of the board. Now tighten only the rear screw with the provided hex key ②. Repeat step for opposite end. **Double-check and readjust both ends as needed until finger assembly is level with VRS extrusion peak.**

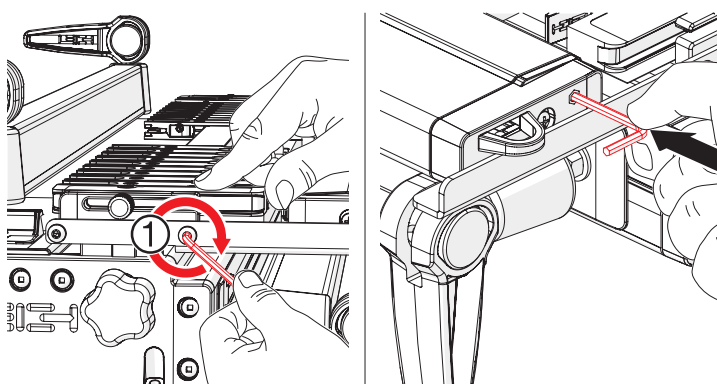

15 Now firmly tighten the other two button head screws ①. The hex key stows in the right hand end of the VRS.

Using the VRS

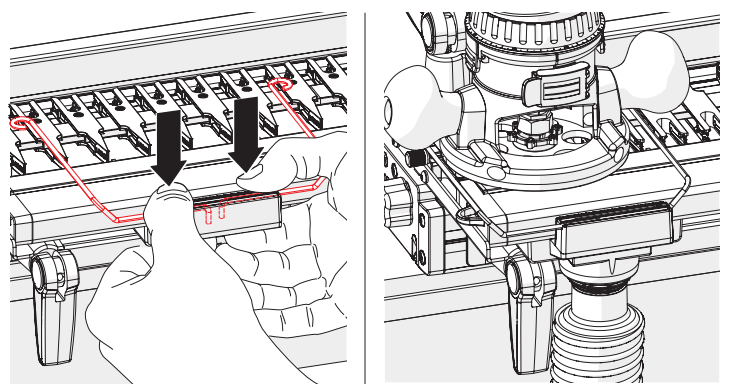

16 Install the two router follower rails by placing the wire ends into the selected holes as far as possible; then using thumb and index finger, squeeze and **snap** the arm down into the end of the slot. Position the wire brackets to allow routing of the workpiece outer edges. Efficient waste collection does not require centering the router bit in the collector.

Using the VRS cont.

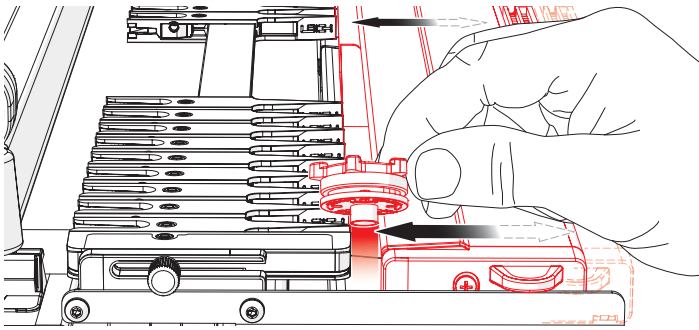

17 Adjust the VRS forward/backwards to create a gap between the extrusion and the jig guide fingers (or template), that is slightly greater than the guide bushing's diameter used.

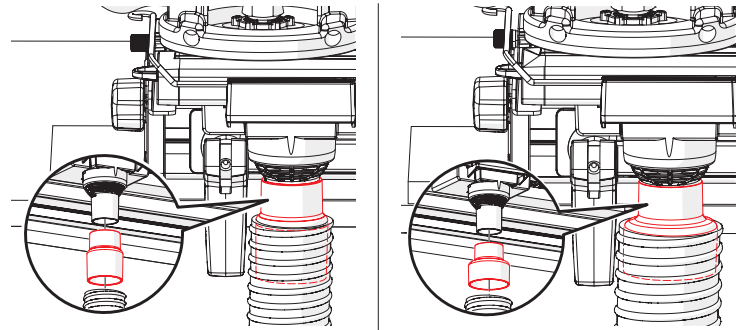

18 Attach the shop vacuum hose directly to the collector nozzle or use one of the two hose adaptors supplied. Try keeping the front clamps vertical and turned away from the hose adaptor to allow maximal router travel.

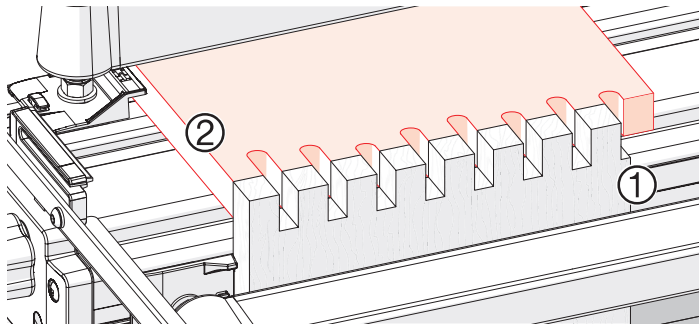

19 For maximum efficiency, always back up vertically mounted workpieces ① with a backer board ②. This not only prevents chips and dust exiting the rear of the board, it also aids in preventing tear out from the rear of the workpiece.

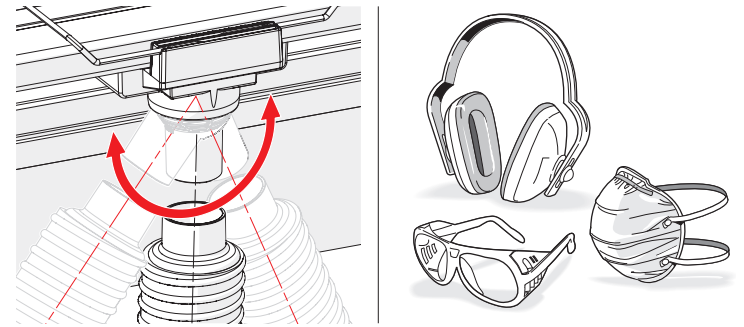

20 Safety The improved swivel joint nozzle on the VRS provides highly efficient dust and chips collection but like all shop dust collection systems, it can't be 100% effective. **When routing, always wear approved protective eye, ear and breathing gear.**

VRS PARTS LIST Ordering: Quote Jig-VRS model, part #, description, quantity

PART #	QUANT	PART DESCRIPTION
5216	1	VRS Extrusion for the VRS16
5212	1	VRS Extrusion for the VRS12
5218	1	VRS Extrusion for the VRS18
5224	1	VRS Extrusion for the VRS24
5424	1	VRS Extrusion for the VRSD24
ALL MODELS		
5230	1	VRS RH End Cap c/w magnet, keeper discs & screw
5240	1	VRS LH End Cap c/w magnet, keeper discs & screw
7145	2	End Cap Screw 10 x 1-1/4" (self tapping)
5300	3	Rare Earth Magnets
4165400	1	Collector Assembly
5315	6	Magnet Keeper Discs
5325	4	Nylon Collector Rollers
5320	1	LH Router Follower Rail
5330	1	RH Router Follower Rail
426150	1	Small Hose Adaptor
426155	1	Large Hose Adaptor
5360	1	Hex Key 1/8"
5555	1	Instruction/parts sheet
D-SERIES JIGS		
371	2	Support Bracket Knob, Nylon Washer
5260	1	Jig Support Bracket RH
5270	1	Jig Support Bracket LH
5380	1	VRS Steel Bracket RH (Black)
5390	1	VRS Steel Bracket LH (Black)
6199	2	VRS Bracket Washers #10
6410	2	VRS Bracket Screws 10-24 x 3/8" Hex-Soc Button Hd
SUPER JIGS and D1600		
5280	1	VRS Steel Bracket RH (black)
5290	1	VRS Steel Bracket LH (black)
6199	4	VRS Bracket Washers #10
6410	4	VRS Bracket Screws 10-24 x 3/8" Hex-Soc Button Hd
8050	1	Jig Support Bracket RH (incl with VRS16 only)
8060	1	Jig Support Bracket LH (incl with VRS16 only)

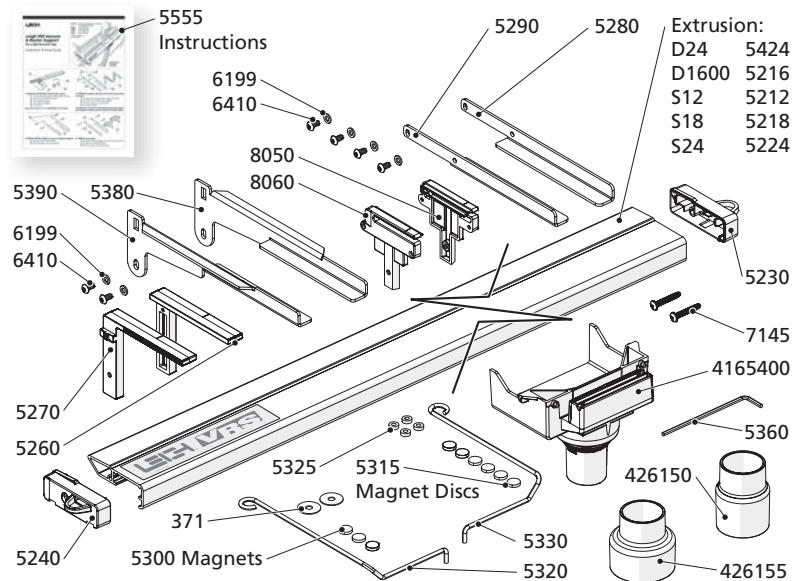

800-663-8932 Canada/USA
leightools.com

© 2007 Leigh Industries Ltd. All rights reserved. No part of this publication may be reproduced, stored in a retrieval system, or transmitted in any form or by any means, electronic, mechanical, recording, or otherwise, without the prior written permission of Leigh Industries Ltd. E&OE (Errors and Omissions Excepted) Updated 09/2022

Printed in Canada

LEIGH
Leightools.com