

# Leigh FMT Pro Mortise & Tenon Jig

*Models FMT Pro, FMT Pro-M*

*User Guide*

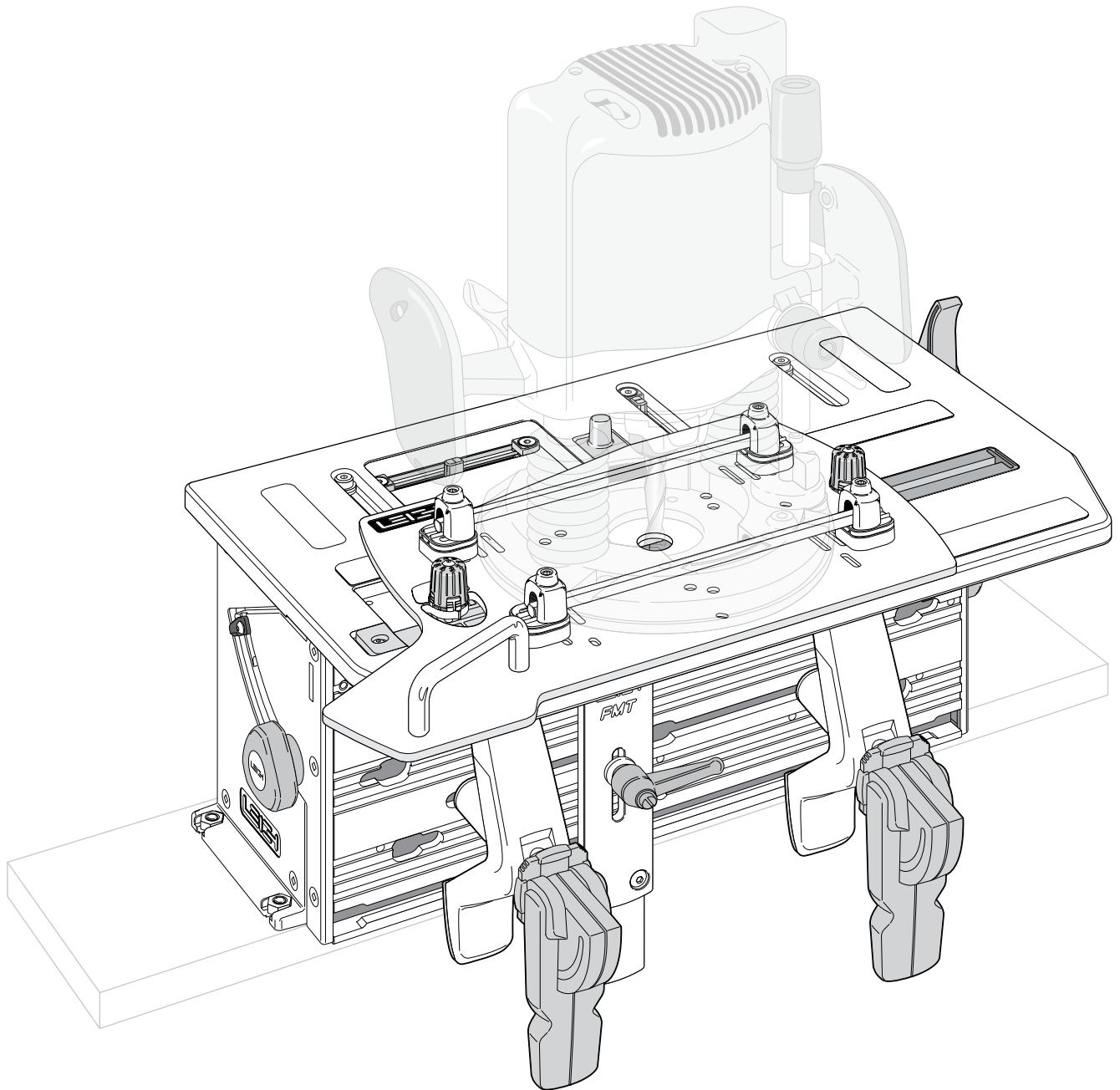

See page 69 for customer support

**800-663-8932**

**LEIGH**® Leightools.com

*Watch the Online Instructional Videos  
in the Support Section at [Leightools.com](http://Leightools.com)*



## Your New Leigh FMT Pro Frame Mortise & Tenon Jig

Congratulations for selecting the unique Leigh FMT Pro, the best mortising and tenoning jig available. The FMT Pro will allow you to rout a large range of sizes of mortise and tenon joints with total control over joint fit.

To gain the most advantage from this unique tool, please read all of this User Guide; carefully set up the jig following the simple setup directions, and thoroughly familiarize yourself with the basic functions and principles of operation. Use scrap wood before attempting any actual projects with valuable hardwood.

## Customer Support

If you have any questions that are not answered in this user guide, please call Leigh Customer Support: **1-800-663-8932** in North

America or email: [help@leightools.com](mailto:help@leightools.com). For support contacts in your country of purchase, see Customer Support on page 69.

*Reminder: If at first you don't succeed, read the instructions!*

## Important! Inches and Millimeters

The Leigh FMT Pro is available in two models; Inch or Metric. The only difference is in the guides and bits used, otherwise the jig itself is identical. Text and illustrations in this English language User Guide indicate dimensions in both inches and millimeters, with "inches" first, followed by "millimeters" in square brackets, i.e.  $\frac{1}{2} \times 2$ " [12x50mm].

**Do not be concerned that the inch/millimeter equivalents are not mathematically "correct".** Just use the dimensions that apply to your guides and bits.



**Before starting, watch the Instructional Video**

**Scan the QR Code to stream to your tablet or smart phone, or view it in the support section at [Leightools.com](http://Leightools.com)**



Scan QR Code

## TECHNICAL BULLETINS

**Downloadable pdfs are available at [leightools.com](http://leightools.com) on the Support page for these How To's and more for your Leigh FMT Pro jig:**

- Mortise & Tenon Joints on Shaped Pieces
- Rout Tenons on Extra Wide Boards
- Side Stop
- Specialty Guides

<b>CHAPTER 1</b>	<b>Mounting the FMT Pro</b> .....	<b>1</b>
<b>CHAPTER 2</b>	<b>Mounting the Router</b> .....	<b>3</b>
	Fence Rod Mounting.....	3
	Screw Mounting .....	8
<b>CHAPTER 3</b>	<b>The FMT Pro Jig</b> .....	<b>11</b>
	The Clamp Plate and Clamping.....	11
	The Table.....	14
	Jig Operation Concept.....	16
	Safety and Router Operation .....	17
	Wood Preparation.....	19
<b>CHAPTER 4</b>	<b>Mortise &amp; Tenon Procedures</b> .....	<b>21</b>
	Single Mortise & Tenon, Test.....	21
	Production Procedures .....	27
	Small Joints.....	28
<b>CHAPTER 5</b>	<b>Multiple Joints</b> .....	<b>31</b>
	Double In Line Joints.....	31
	Twin Joints.....	33
	Quadruple Joints.....	35
	Triple Joints .....	37
<b>CHAPTER 6</b>	<b>Workpiece and Joint Options</b> .....	<b>41</b>
	Different Workpiece Thicknesses.....	41
	Longer and Shorter Joints.....	42
	Thicker and Wider Boards.....	44
<b>CHAPTER 7</b>	<b>Special Joints</b> .....	<b>47</b>
	Angled Joints .....	47
	Through Tenons.....	48
	Bridle Joints.....	50
	Asymmetric Tenons .....	51
	Haunched Joints .....	51
	Doweling .....	54
<b>Appendix I</b>	<b>Joint Specifications, Guide and Bit Selection</b> .....	<b>55</b>
	Joint Specifications.....	55
	Guide and Bit Selection.....	57
<b>Appendix II</b>	<b>Jig Adjustments</b> .....	<b>61</b>
<b>Appendix III</b>	<b>Parts List</b> .....	<b>63</b>
<b>Appendix IV</b>	<b>Customer Support</b> .....	<b>69</b>

## Add Leigh accessories to make your jig even more versatile.

### Optional Specialty Guides

#### Square Tenons

Square tenons are often used for replicating period furniture.



Item 670900

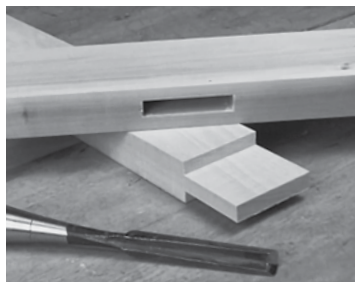

#### Y-Axis Mortise

In instances when mortises need to be routed at 90° to the clamp plate, this guide does the trick.



Item 6701YAM



#### Louver Doors

Make beautiful louver doors with these guides and bit.

L/R matching pair  
Item 6701LGP



1/4" HSS Louver Guide Bit, 1/2" shank  
Item 168-500



### Optional Guides, Bits and Accessory Kit for Great Savings

#### Joint Guides

Three optional guide sets are available increasing the number of joint sizes you can make to 68! 16 optional guides in 1/4", 3/8" and 1/2" (6, 10 and 12mm) sizes, make a complete set. Each guide can be purchased individually or as a set for better value. Buy all three or as part of the accessory kit below for even greater savings. Item 6720 or 6820

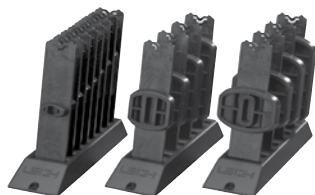

#### Router Bits

8-piece set in HSS or Solid Carbide opens up your possibilities for joint sizes. Item 162-180 or 162-180C

**Accessory Kit for Savings** Combine an optional guide set and boxed inch bit set for the best savings. Includes an 8-piece boxed inch bit set and 16 optional guides in 1/4", 3/8" and 1/2" (6, 10 and 12mm) sizes for a complete set. Item ACMT or ACMTC

### Optional Extra Clamps Save Time

Leigh Surface clamps are identical to FMT Pro clamps. Save time when switching between mortise and tenon boards. **Bonus!** This tough, versatile cam-action clamp can also be mounted on any flat surface, on any angle or on a table saw. You can never have too many clamps.

Item SHDC1 Surface mount (one clamp)

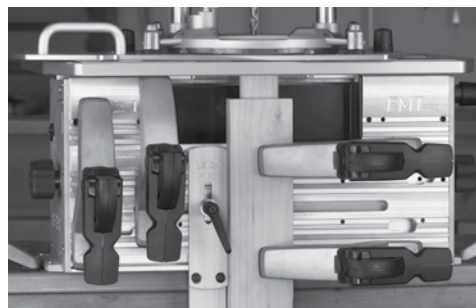

Routing tenons with mortise board clamps in place

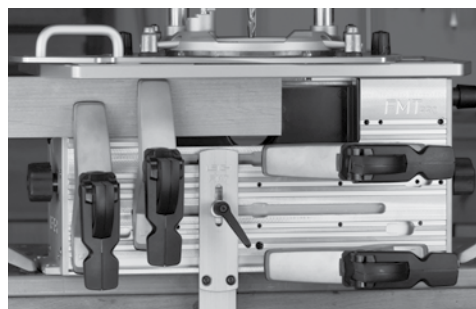

Routing mortises with tenon board clamps in place



1/8" to 3" capacity



Use on jigs and fixtures



Use vertically on bench

Visit [www.leightools.com](http://www.leightools.com) for more details