

## TD330 User Guide

# CHAPTER 4 Mounting & Assembly

The following steps will show you how to prepare the beam and assemble your Leigh TD330 Through Dovetail Jig.

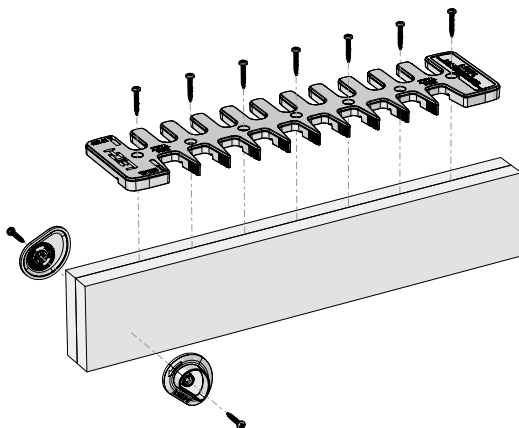

### You will need:

- A workbench with vice or a portable workbench
- 2 pieces of 3/4" [19mm] MDF to make a beam 1-1/2" x 3-1/2" x 19" [38mm x 90mm x 483mm]
- Router with 1/2" collet
- Electric drill, preferably bench or pedestal, but handheld will work
- 3/32" drill bit
- Two Quick-Grip clamps
- Square
- Ruler or tape measure
- No.2 Phillips screwdriver
- Wood glue

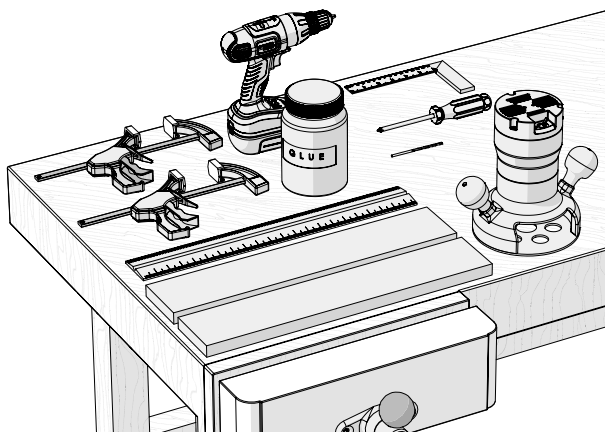

**Note:** The finished beam must be 1-1/2" [38mm] thick.



## Watch the Online Instructional Video



*Reduce your learning time dramatically!* Stream to your smart phone or tablet to use in your workshop while you're working. See Instructional Videos section in Support menu at [leightools.com](http://leightools.com) or scan QR code for instant video.

**4-1 Watching the online video in addition to reading this user guide will reduce your learning time dramatically.** The video can be streamed to your smart phone or tablet and used in your shop as a visual reference. Visit [leightools.com](http://leightools.com) and find the video in the Support section.

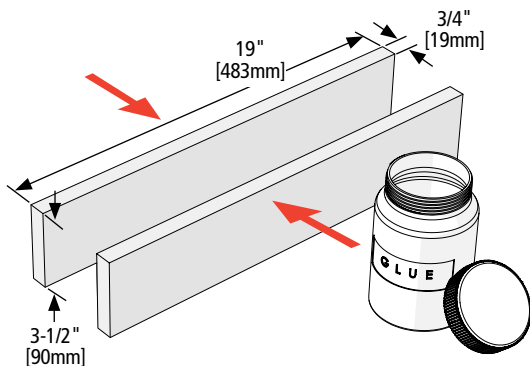

**4-2 Making the Beam** We recommend laminating two pieces of MDF: 3/4" [19mm] x 3-1/2" [90mm] x 19" [483mm]. Clamp the glued pieces together and set aside to dry. Be sure the top edges are flush and free of glue residue. Alternate materials may be used, eg, a common 2x4 in North America, however the finished thickness must be 1-1/2" [38mm]. See Step 4-14 for special instructions. If you are making dovetails using narrow boards, see Step 6-66.

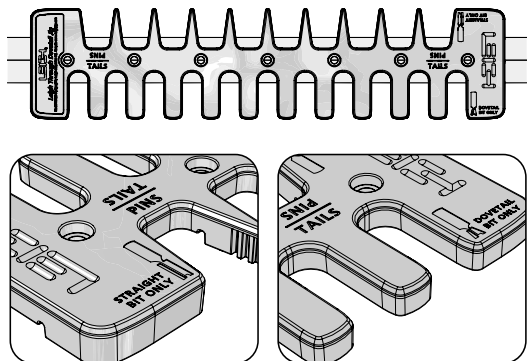

**4-3** One side of the template is used for routing pins, and the other side for routing tails.

**PINS** and **TAILS** is clearly marked on the template, as well as which bit to use.

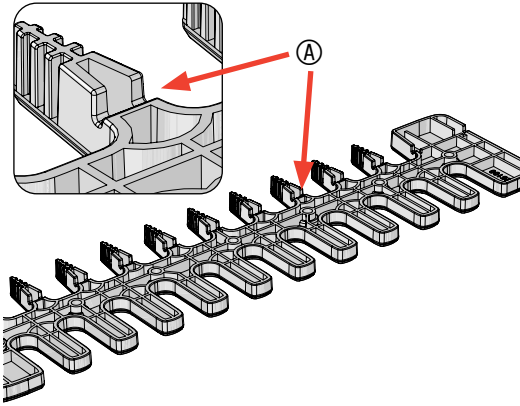

**4-4** The **PINS** side of the template has positioning ridges (A) molded into the underside.

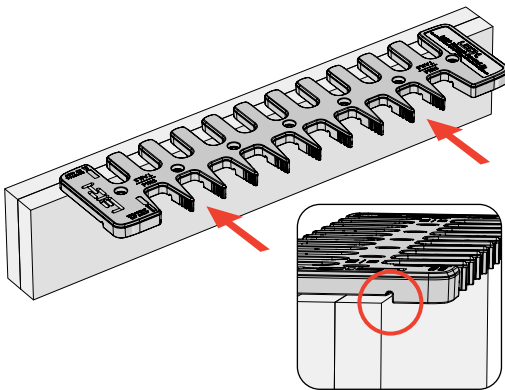

**4-5** With the **PINS** side of the template facing you, lay it flat on the top of the beam and slide it backwards until the positioning ridges contact the edge of the beam. Center the template left to right. The template is now positioned correctly.

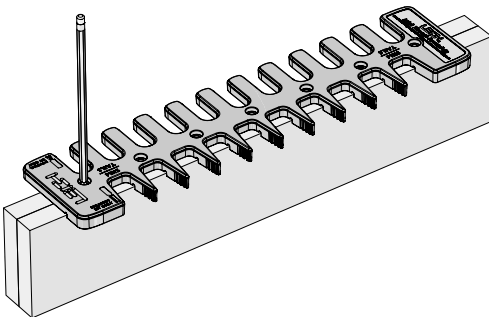

**4-6** Use a pencil and mark the location of all screw holes on the top of the template. Hold the template in place and proceed to the next step.

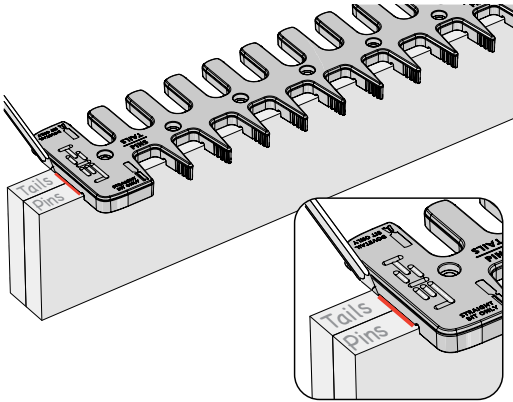

**4-7** Use the left edge of the template as a guide and draw a pencil line completely across the top of the beam.

Mark **PINS** and **TAILS** on the top left side of the beam as indicated.

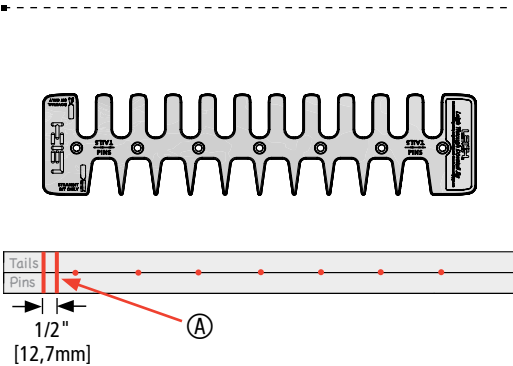

**4-8** Remove the template and place a mark  $1/2$ " [12,7mm] to the right of the line on the top of the beam. Use a square and draw a second line **A** completely across the top of the beam at the  $1/2$ " [12,7mm] mark. This line will be used to position the side stops.

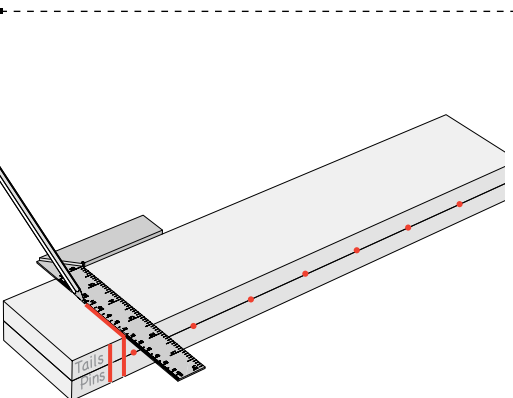

**4-9 Mark layout lines for the side stops.** Place the beam flat on the workbench with the **TAILS** side up. Use a square and draw a line perpendicular from the side stop positioning mark on the top of the beam.

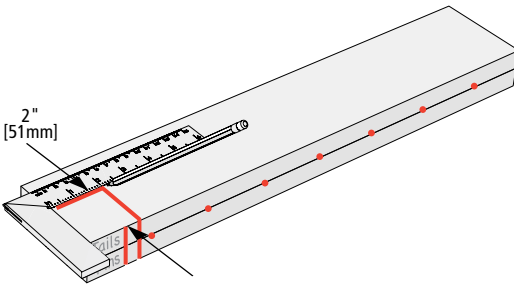

**4-10** Next, draw a horizontal line, 2" [51mm] down from the top of the beam. Make sure the horizontal line intersects the vertical line. This is the mounting point for the side stops.

Rotate the beam and repeat for the **PINS** side, **at the same end of the beam.**

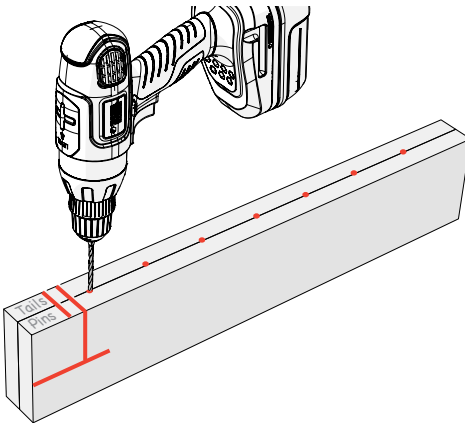

**4-11** Use a drill press or hand drill with a 3/32" bit to drill pilot holes at all screw hole locations on the top of the beam and at the side stop positioning marks.

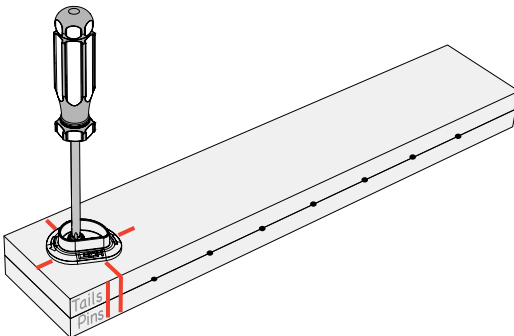

**4-12** Place the beam on the workbench with the **TAILS** side facing up. Align the center of a side stop with the pilot hole and attach it using an included screw. Use a screwdriver, not a power drill, to attach the side stop.

Repeat the process on the **PINS** side of the beam.

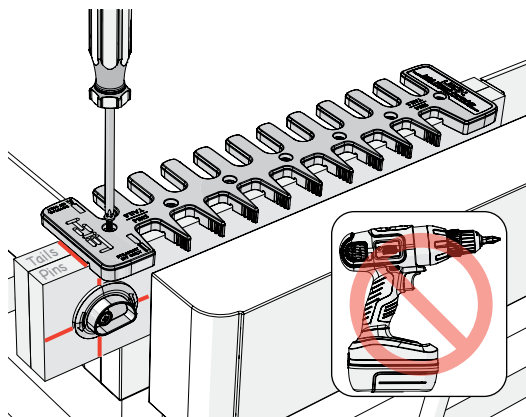

**4-13** Clamp the beam in the vice with the PINS side facing you. With the PINS side of the template toward you, place it on the beam and align it with the pre-drilled holes. Use a screwdriver to attach the template with the included screws. Do not tighten the screws yet! See next step.

**⚠ Do not use a power drill, as it may overstress the template.**

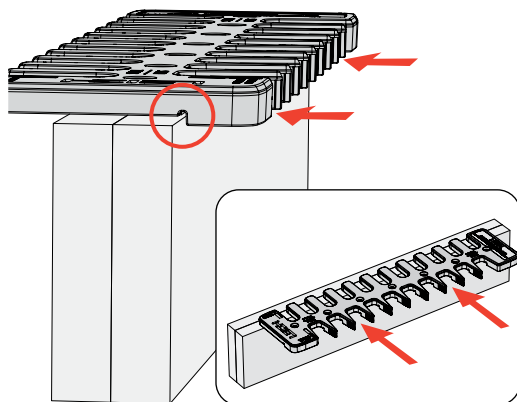

**4-14** Make sure the positioning ridges (see Step 4-5) are held against the beam while tightening the screws.

**4-15** As a last resort, you can use a straight, flat 19" [483mm] piece of common 2x4. However this may generate a lot of tearout on the beam. Since a 2x4 has rounded corners, preparation is required. **Note:** the finished thickness must be 1-1/2" [38mm].

Use a table saw, router table or jointer to skim off the top surface of the 2x4. Now go back to Step 4-4 for the rest of the beam preparation.

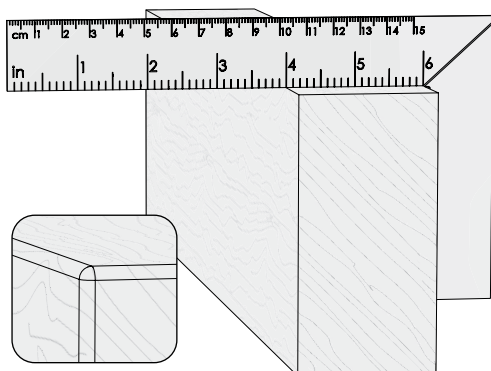

**4-16 Prepare the Beam**

To prevent tear-out of your good material, grooves must be routed in all template openings, on both sides of the beam, as shown in the following steps.

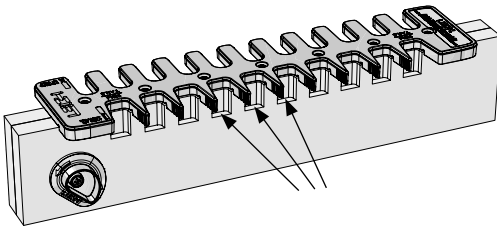

Preparing the beam is particularly important when using a common 2x4 because its side grain will tear out badly.

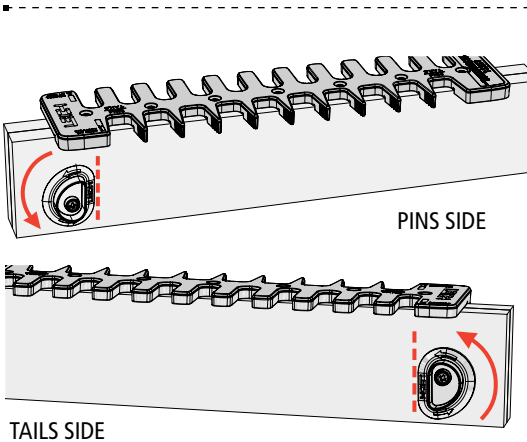

**4-17** Turn both side stops until the straight edge is vertical and facing toward the middle of the beam.

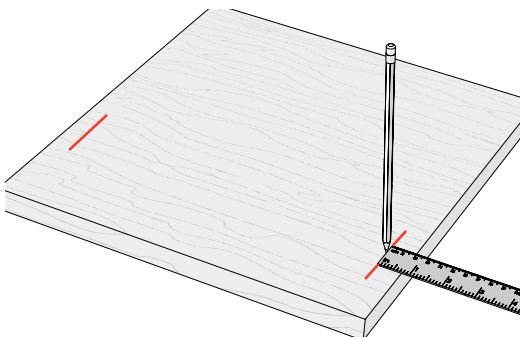

**4-18 Depth of Cut** Select a board at least 13-1/4" [330mm] wide and 1/2" [12,7mm] to 3/4" [19mm] thick. Length is not important as long as it can be clamped safely in the vice.

Mark a depth of cut line 3/4" from the top and bottom ends of the board. Clamp the board in the vice with the depth of cut line facing you.

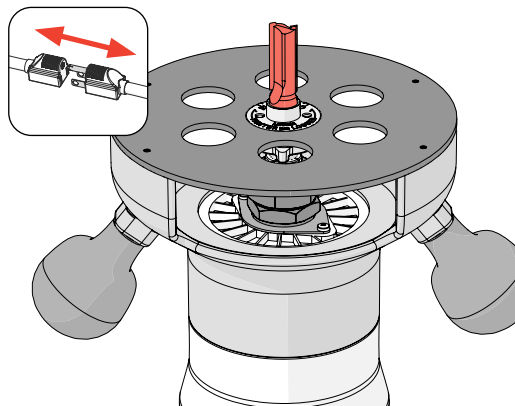

#### 4-19 Install the Straight Bit

With the router unplugged, install the included 1/2" straight bit. The bit goes through the guide bushing and fits in the router collet. Tighten the collet.

The collet and bit must not touch the eBush or eBush nut. Rotate the collet to ensure both spin freely.

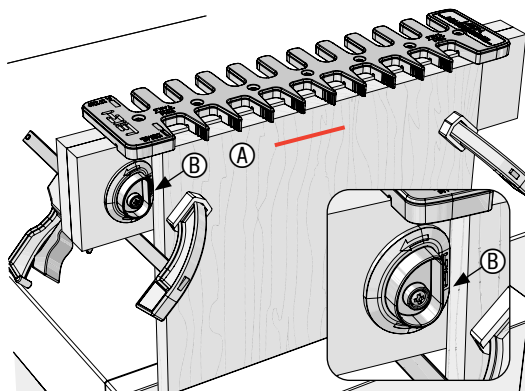

**4-20** With the **PINS** side of the jig facing you, place the jig on the board **A**. Slide the jig to the right until the side stop touches the left edge of the board **B** and clamp the jig in place.

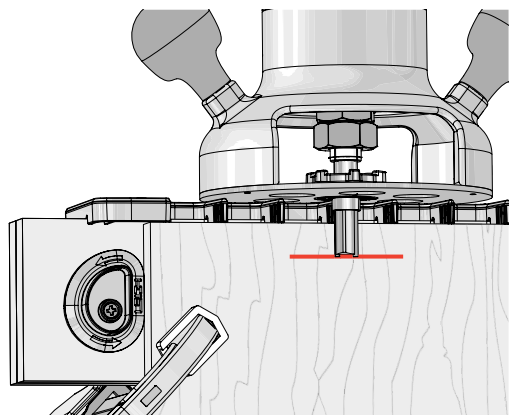

**4-21** Place the router on the jig and adjust the tip of the bit up or down until it's at the center of the line.

Rotate the collet to ensure it spins freely.



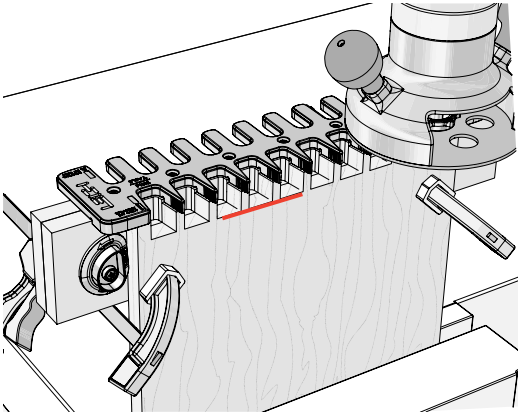

**4-22** Hold the router firmly and rout through the board and into the beam, in each template opening.

Be sure the guide bushing touches the left side of each template opening on the way in and the right side on the way out.

Check to make sure all the grooves are cleanly routed before removing the jig.

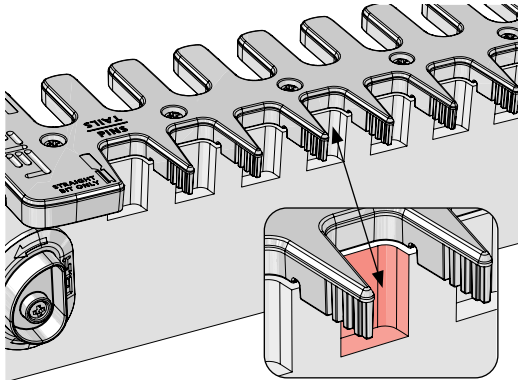

**4-23** Remove the jig from the board.

There will now be a clean groove in each template opening on the **PINS** side of the beam.

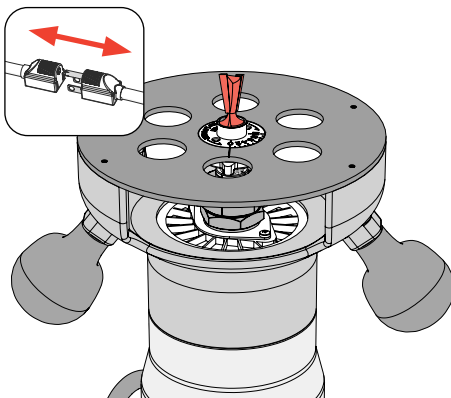

#### **4-24 Install the Dovetail Bit**

Unplug the router and install the included 1/2" 8° dovetail bit. The bit goes through the guide bushing and fits in the router collet. Tighten the collet.

The collet and bit must not touch the eBush or eBush nut. Rotate the collet to ensure both spin freely.

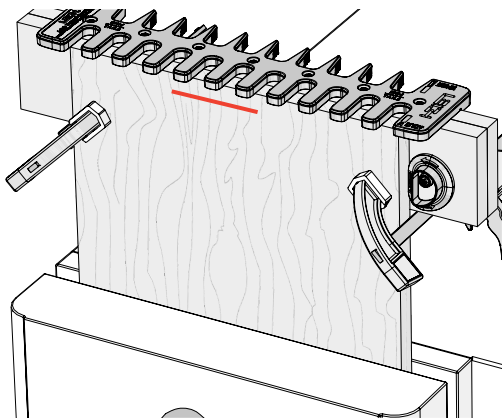

**4-25** Unclamp the board, flip it end for end, keeping the depth of cut lines facing you and reclamp it in the vice.

Place the jig on the board with the **TAILS** side toward you and slide it to the left until the side stop touches the board edge.

Clamp the jig in place.

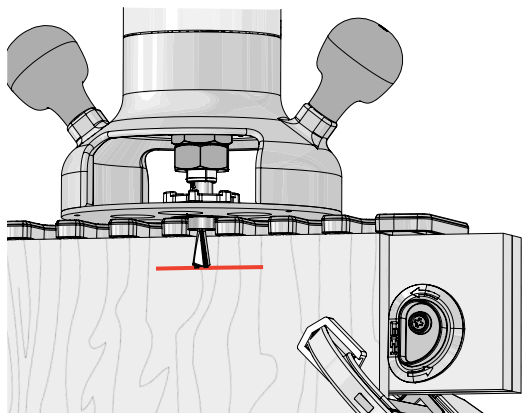

**4-26** Place the router on the jig and adjust the bit until the tip is at the depth of cut line.

Rotate the collet to ensure it spins freely.

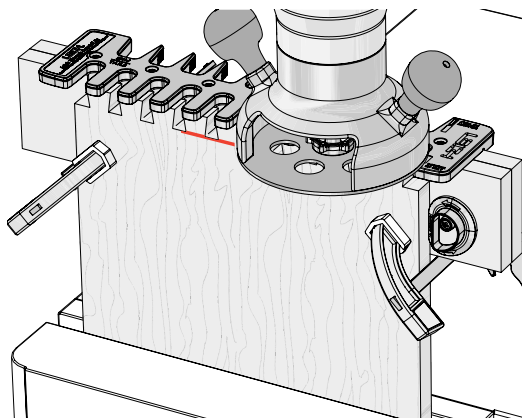

**4-27** Hold the router firmly and rout through the board and into the beam, in each template opening.

Be sure the guide bushing touches both sides of the template opening.

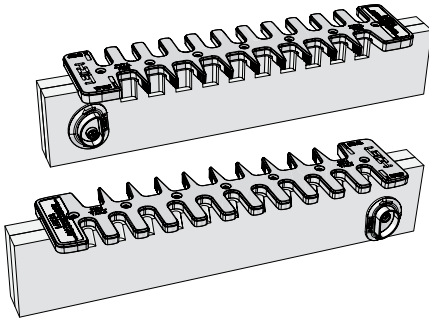

**4-28** The beam and jig are now ready to use. ■

This page is left blank intentionally.