

Parts List

PART NO.	QUANTITY PER JIG	PART DESCRIPTION
311	2	1/2" x 3" Compression Springs
371	6	1/4" x 7/8" x .031" Nylon Washers
501	4	8-32 x 3/8" Square Socket No.2 Robertson
3080	1	Side Stop Fence Knob
5100	2	Sub-Base Fence Rods
5130	2	M6x14mm Hex Socket Button HD Cap Screws (for Festool)
6000	1	LH. End-Housing
6005	1	RH. End-Housing
6010	1	Top Extrusion
6015	1	Bottom Extrusion
6020	11	10-1 1/4" Self tapping # 2 Robertson Oval HD Screws
6026	2	18mm x 6.4mm x 1.2mm Steel Washers
6030	6	1/4 - 20 Hex Nuts (for Quadrant Knobs & Jig Holddown)
6040	2	Limit Stop Posts
6050	1	Angle Indicator Decal
6055	1	UHMW Strip Long
6056	3	UHMW Strip Short
6060	4	1/4-20 x 1" Flat HD Machine Screws (Jig Hold-down)
6100	1	Clamp Plate
6105	1	Vacuum Box
6110	1	LH Quadrant
6115	1	RH Quadrant
6120	2	Quadrant Bushings
6125	3	Hex Socket Flat Point Set Screws 1/4-28 x 3/8"
6130	2	Outrigger Bars
6135	1	Quadrant Angle Indicator
6140	8	6-32 X 3/8" Hex Socket Button HD Screws
6145	3	10 x 1 1/4" Self Tapping #2 Robertson SQ Drive Pan Hd Screws
6155	5	Hex Socket Flat Point Set Screw 1/4-28 X 5/8"
6166A		Sidestop Fence Assembly complete
6166	1	Sidestop Fence
6171	1	Sidestop Squaring Block
6191	1	Side Stop T-Bolt
6199	2	Side Stop Fence Washer
6410	2	10-24 x 3/8" Hex Socket Button HD Cap Screw
6175	4	10-24 x 1/2" Flat HD Hex Socket Machine Screws
6195	8	8-32 x 3/4" Flat HD Machine Screws (for Outrigger & Low Shim Spacers)
6196	4	8-32 Hex Nuts (for Outriggers)
6200	2	Clamp T-Bolts 3/8"-16
6205	3	3/8" x 3/4" x .062" Nylon Flat Washers
6210	2	3/8"-16 Clamp T-Bolt Brass nuts
6220	2	Clamp Arm
6225	2	Clamp Arm Heel Pads
6230	2	Clamp Arm Toe Pads
6235	2	Clamp Swivel Pads
6240	2	Clamp Lifters
6245	2	Clamp Lifter Springs
7025	2	Quadrant Knobs
801-375	2	Cam-Action Speed-Clamps
802-375	2	Speed-Clamp Step Washers

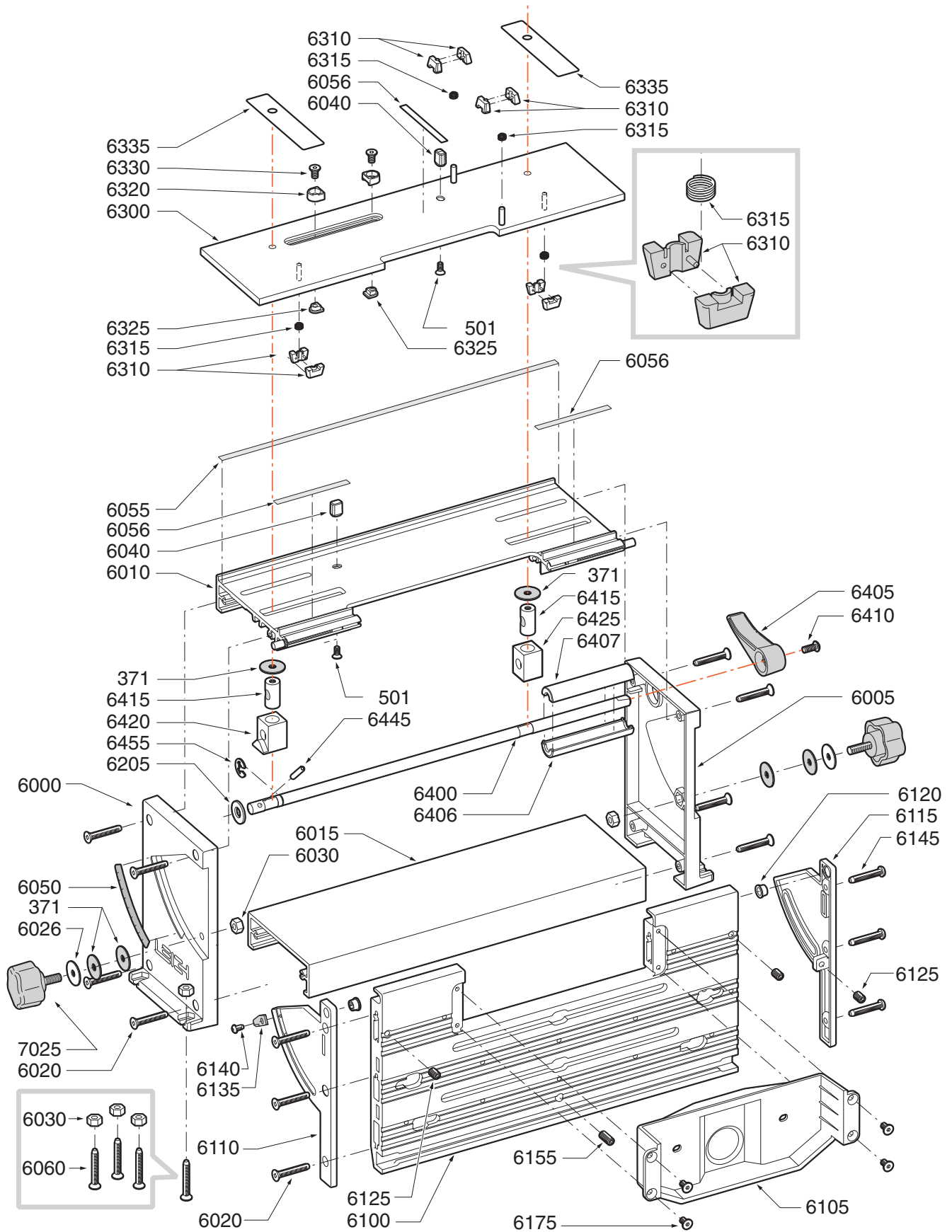

PART NO.	QUANTITY PER JIG	PART DESCRIPTION
6300	1	Intermediate Plate Assembly c/w pressed-in Pins
6310	4 pairs	Wedge Blocks
6315	4	Wedge Block Compression Springs
6320	4	Limit Stops
6325	4	Limit Stop Nuts
6330	4	10-24 x 3/8" Hex Socket Nyloc Flat HD Machine Screws
6335	2	UHMW Glides
6400	1	Table Clamp Rod
6405	1	Table Clamp Handle
6406	1	Clamp Handle Sleeve- Lower
6407	1	Clamp Handle Sleeve- Upper
6410	4	10-24 x 3/8" Hex Socket Button HD Cap Screw
6415	2	"Pull Down" Clamp Block
6420	1	LH "Push-Up" Clamp Sleeve
6425	1	RH "Push-Up" Clamp Sleeve
6430	2	Hex Socket HD Shoulder Screws 1/4" x 3/4" (10-24)
6435	2	1/4" Flat Washers SS
6440	2	1/4" Fibre Washers
6445	1	5/32" x 1" Spring Pin
6455	1	SnapRing 3/8" x .035" thick
6500	1	Table Plate Assembly c/w Decals & Teflon Pads
6505	1	Sight
6510	1	LH Sight Rail
6515	1	RH Sight Rail
6530	2	Sight Rail Spring Detents
6535	1	R.H. Guide Pin "Track"
6540	4	Teflon Decal Pads
6550	1	Guide Latch
6555	1	Guide Latch Spring
6600	1	Sub-Base Plate Assembly c/w Decals & Teflon Pads
6605	1	LH Teflon Pad
6610	1	RH Teflon Pad
6615	2	Guide Pins
6620	2	Guide Pin Bushes
6625	2	Guide Pin Knobs
6626	2	Guide Pin Height Washers
6630	2	O-rings 4.5mm I.D. x 1mm
6633	2	O-rings 7.0mm I.D. x 1mm
6635	4	Sub-Base U-posts (includes 2 screws in each)
6640	4	"Low" Shim-Spacers
6645	4	"High" Shim-Spacers
6655	4	8-32 x 1" No. 2 SQ DR Flat HD Machine Screws (for High-Shims)
6660	1	Sub-Base Handle
6665	1	"INCH" Mandrel
6670	1	"METRIC" Mandrel

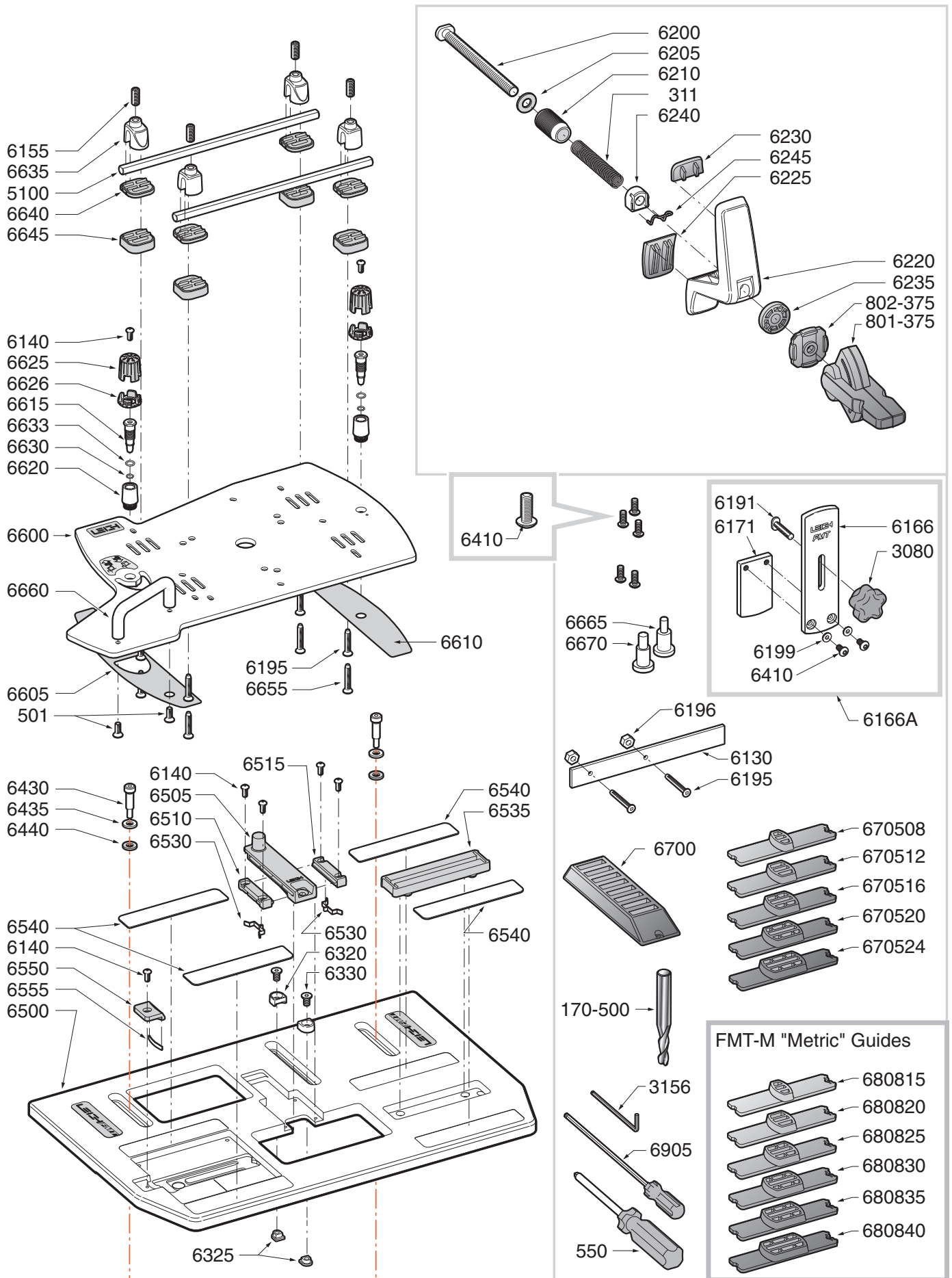

PART NO.	QUANTITY PER JIG	PART DESCRIPTION
670508	1	5/16" x 1/2" Template Guide
670512	1	5/16" x 3/4" Template Guide
670516	1	5/16" x 1" Template Guide
670520	1	5/16" x 1 1/4" Template Guide
670524	1	5/16" x 1 1/2" Template Guide

FMT-M Metric Guides

680815	1	8 mm x 15 mm Template Guide
680820	1	8 mm x 20 mm Template Guide
680825	1	8 mm x 25 mm Template Guide
680830	1	8 mm x 30 mm Template Guide
680835	1	8 mm x 35 mm Template Guide
680840	1	8 mm x 40 mm Template Guide

6700	1	Template Guide Stand
6900	1	FMT User Guide
6905	1	LEIGH 1/8" Ball End Hex Screw Driver
3156	1	5/64" Hex Key (for No.6 Button HD)
550	1	LEIGH No.2 Robertson Screw Driver
170-500	1	5/16" dia x 1/2" Shank HSS Spiral Upcut Bit

Bit Not Included With FMT-M From Factory

