

## RTJ400 OPERATION

## CHAPTER 13

## 3/32" Box (Finger) Joints

**IMPORTANT  
SAFETY NOTE**

Before using your Leigh RTJ400 you must have completed the preparatory steps listed in the previous pages, including reading the jig safety recommendations in Chapter 3.

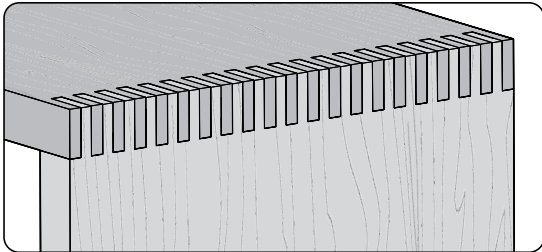

### Watch the Online Instructional Video



Scan QR Code

**Reduce your learning time dramatically!** Stream to your smart phone or tablet to use in your workshop while you're working. See Instructional Videos section in Support menu at [leightools.com](http://leightools.com) or scan QR code for instant video.

**13-1 Getting Started**

Review the drawing below. **Symmetrical** joints have pins (A) on both edges of one board, and sockets (B) on both edges of the mating board. **Asymmetrical** joints have a pin (C) on one edge and a socket (D) on the other edge of each board.

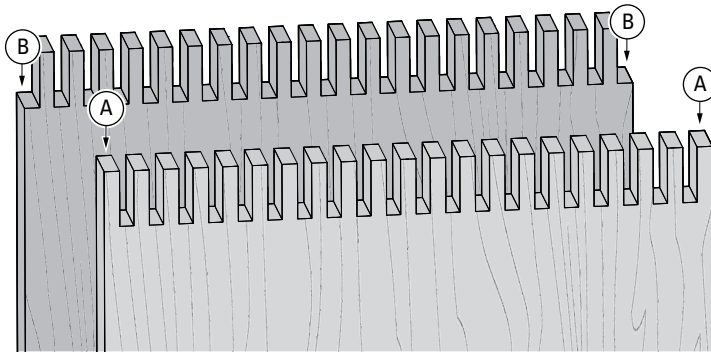

SYMMETRICAL

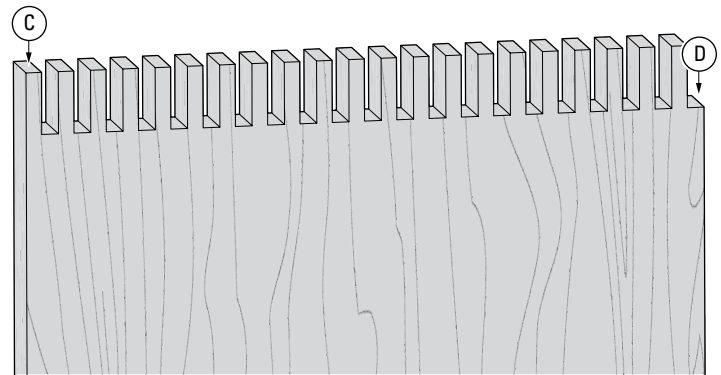

ASYMMETRICAL

**13-2 Bit, Guide Bushing and Blocker**

3/32" box joints are routed with the optional 3/32" straight bit 163, the e10 guide bushing (eBush) and a blocker. They can be routed in board thicknesses up to the maximum cutting depth of the bit, in this case, 3/8" [9.5mm].

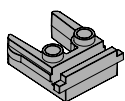

Blocker

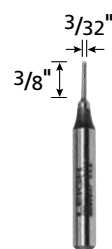
e10 eBush  
(Guide Bushing)163  
(Optional)**BOX JOINT BIT CUTTING DEPTH**

Bit Diameter	3/32"											
Item No. HSS (Optional)	163											
Item No. Solid Carbide	-											
Depth of Cut	<table border="1"> <tr> <td>0"</td> <td>1/8"</td> <td rowspan="6"> </td> </tr> <tr> <td>1/4"</td> <td>3/8"</td> </tr> <tr> <td>1/2"</td> <td>5/8"</td> </tr> <tr> <td>3/4"</td> <td>7/8"</td> </tr> <tr> <td>1"</td> <td></td> </tr> </table>	0"	1/8"		1/4"	3/8"	1/2"	5/8"	3/4"	7/8"	1"	
0"	1/8"											
1/4"	3/8"											
1/2"	5/8"											
3/4"	7/8"											
1"												

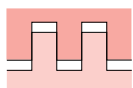

**Symmetrical Joints** have a full pin at each board edge. The total number of pins and sockets will always be an odd number.

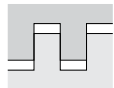

**Asymmetrical Joints** have a full pin at one edge and a full socket at the other. The total number of pins and sockets will always be an even number.

**Symmetrical Board Width Chart for 3/32" Box Joints**

<b>Total Pins &amp; Sockets</b>	3	5	7	9	11	13	15	17	19	21	23	25	27	29	31	33	35	37	39	41
<b>Inches</b>	9/32"	15/32"	11/16"	7/8"	1 1/16"	1 1/4"	1 13/32"	1 21/32"	1 27/32"	2 1/32"	2 1/4"	2 7/16"	2 5/8"	2 13/16"	3 1/32"	3 7/32"	3 13/32"	3 19/32"	3 11/16"	4
<b>Millimeters</b>	7	12	17	22	27	32	37	42	47	52	57	62	67	71	77	82	87	91	97	102

**Asymmetrical Board Width Chart for 3/32" Box Joints**

<b>Total Pins &amp; Sockets</b>	4	6	8	10	12	14	16	18	20	22	24	26	28	30	32	34	36	38	40
<b>Inches</b>	3/8"	9/16"	25/32"	31/32"	1 1/32"	1 11/32"	1 1/16"	1 3/4"	1 13/16"	2 1/8"	2 11/32"	2 17/32"	2 23/32"	2 29/32"	3 1/8"	3 3/16"	3 1/2"	3 11/16"	3 29/32"
<b>Millimeters</b>	10	15	20	25	29	34	40	44	49	54	60	64	69	74	79	84	89	94	99

**13-3** Board widths are determined by the total number of pins and sockets in the joint design and whether the joint is symmetrical or asymmetrical. Use this chart to determine board widths up to 4" [102mm] for 3/32" joints. For wider boards, see [www.leightools.com](http://www.leightools.com).

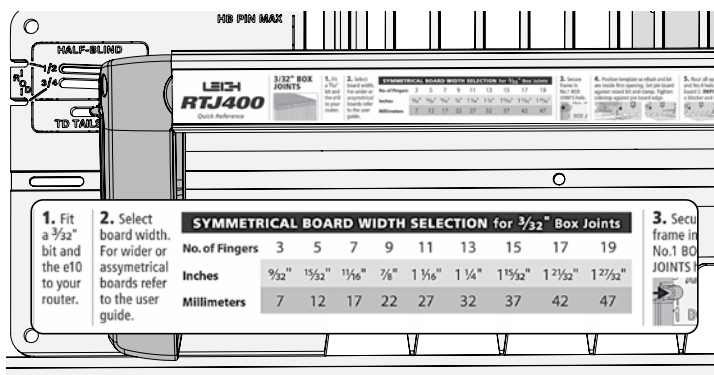

**13-4** Use the Quick Reference strip to determine the correct straight bit and eBush combination. **IMPORTANT NOTE:** Read the whole chapter before routing any boards, and see quick fit instructions in 13-15.

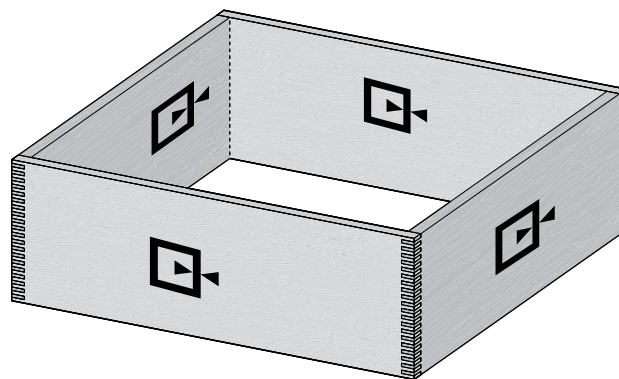

**13-5 Making a Box** Note the symbols indicating either side of the pin and socket boards can face in or out. With box joints, the same edge of the board goes against the side stop.

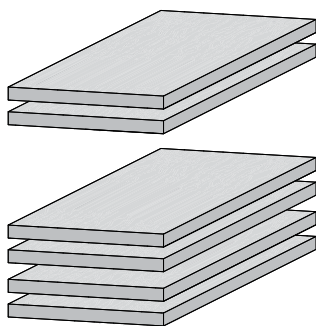

**13-6** Prepare four similar boards 1/4" x 4 5/8" by about 8" long [10mm x 115mm x 200mm]. For the quick fit test you will need two test boards about 1/4" or 3/16" thick. Boards of different thicknesses may also be joined. **IMPORTANT: Read this whole chapter before routing any boards.**

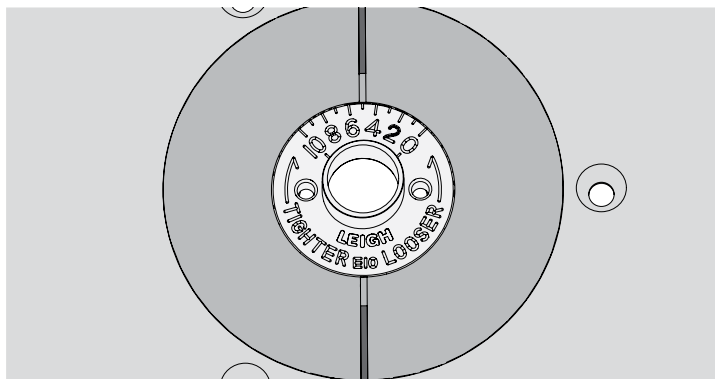

**13-7** Fit the e10 eBush to the router table insert ring, set to 5.

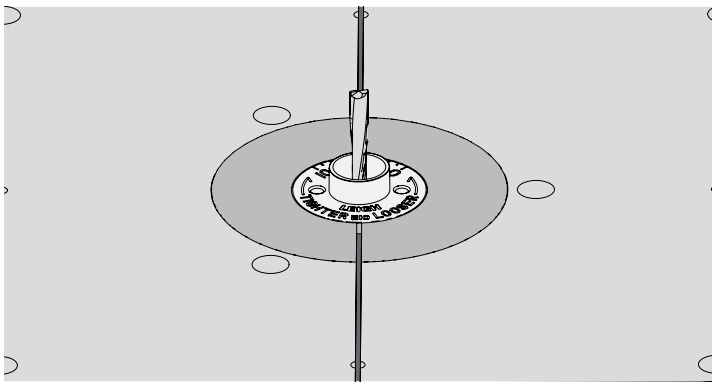

**13-8** With the power disconnected from the router, install the optional 3/32" Leigh 163 bit. **⚠** Make sure the bit spins freely within the bushing before reconnecting the power.

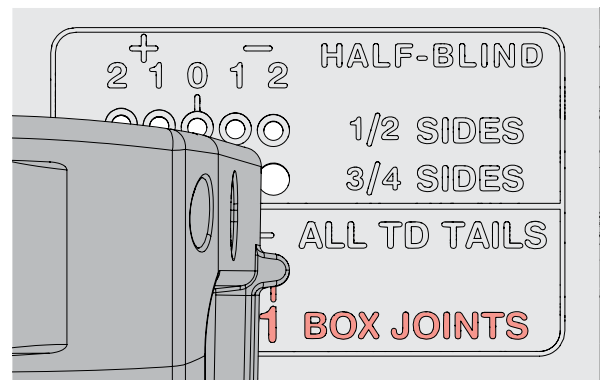

**13-9** Insert the right frame pin in the **No.1 hole, BOX JOINTS** mode and the left frame pin in the **TD TAILS & BJ slot** and latch the frame.

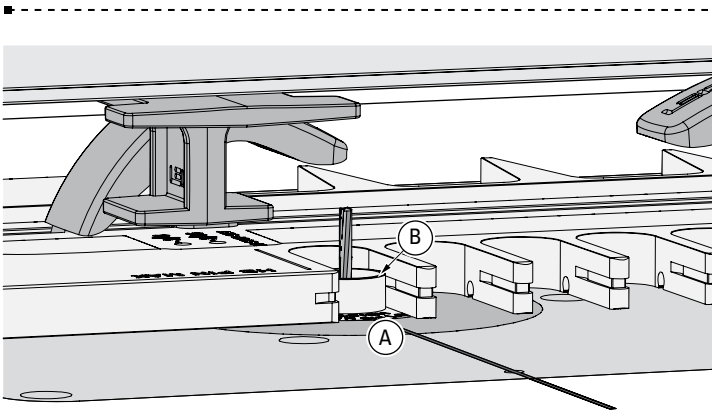

**13-10** Raise the bit above the template and move the template, putting the eBush in the first template opening **A** with the inner edge of the opening **B** touching the bushing.

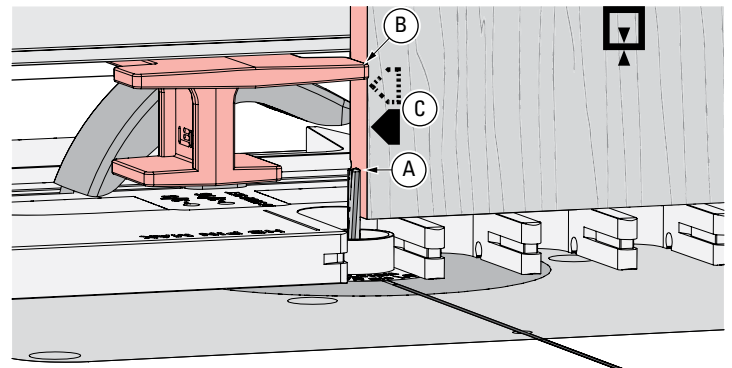

**13-11** Set pin board 1 on the template, touching the 3/32" bit **A**. Clamp in place. Move the side stop to touch the board edge **B** and tighten it. **The 3/32" box joint requires moving the template from right to left in four steps. Always keep the same side edge of the board to the side stop when routing box joints C.**

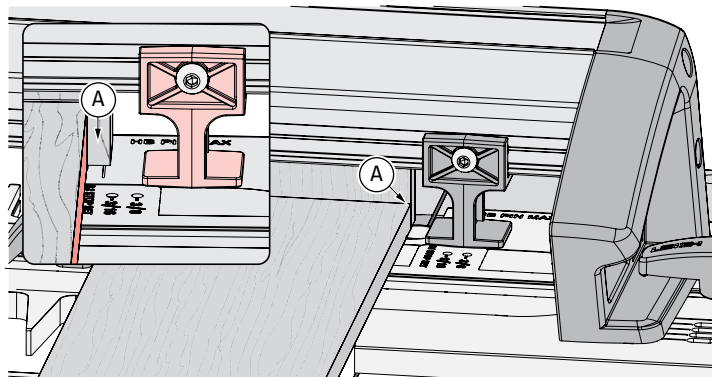

**13-12** Position a backer board at least 3/16" [4.5mm] from the board edge **A**. This prevents the backer board from interfering with the side stop when the frame is repositioned in subsequent steps. The backer board stays in place for the complete procedure.  
**Note: Clamp removed for clarity.**

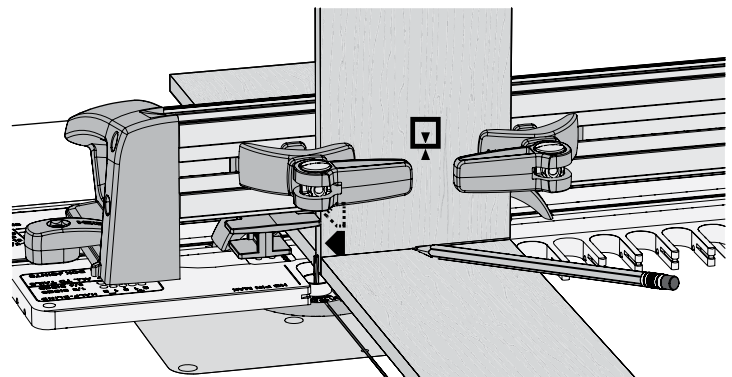

**13-13** Place the end of a socket board on the template and pencil a line on the pin board.

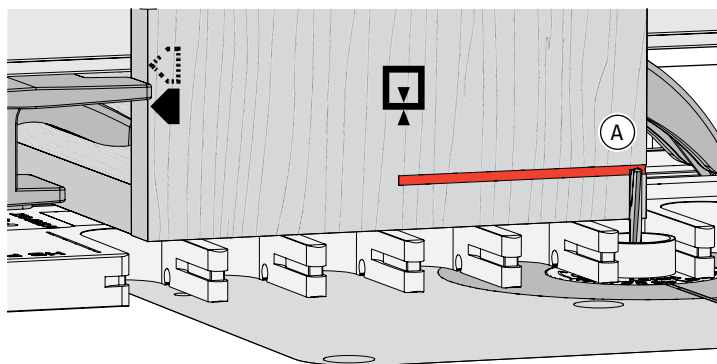

**13-14** Adjust the bit until the tip is level with the center of the pencil line on pin board 1 (A). ⚠ Double check that the bit still rotates freely. **IMPORTANT: Bit height determines the flushness of the joint, so set your bit properly the first time.** Adjustments for flushness are at the end of the chapter.

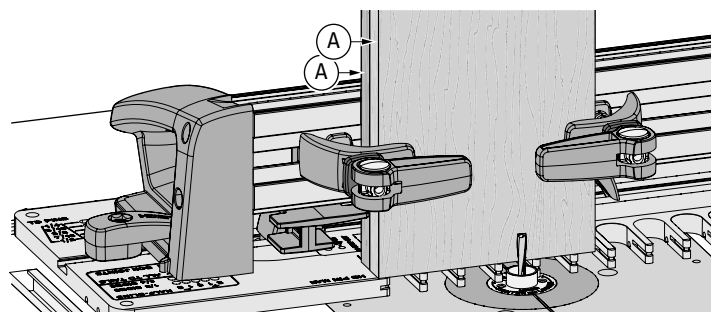

**13-15 Quick Fit Test** To save time and wood, clamp the two approx.  $\frac{3}{16}$ " thick scrap **test** boards in the jig, back to back (A). ⚠ **Review the remaining steps in this Chapter.** Rout both boards in all four frame pin positions 1, 3, 2 and 4. Join the routed boards and make the joint fit adjustments in the next three steps. Don't worry about board edge alignment, the test is for joint fit only.

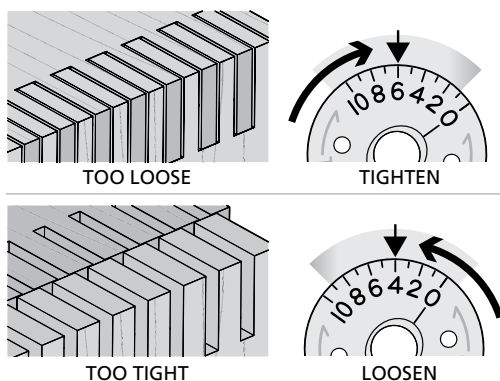

**13-16 Joint Fit Adjustment** Join the boards, keeping the same side board edges together. If the joint is too loose, turn the eBush to a higher number, as shown in the next step. If too tight, turn the eBush to a lower number.

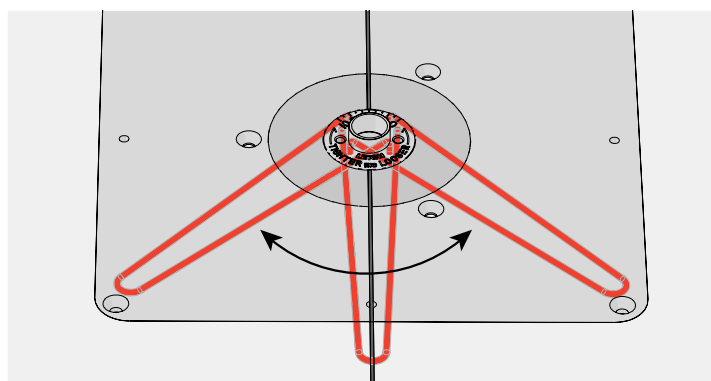

**13-17** Each increment on the eBush changes the joint glue line fit by 0.002" [0.05mm]. Half an increment, a mere 1000th inch! **Re-tighten the eBush nut after each guide bushing adjustment.**

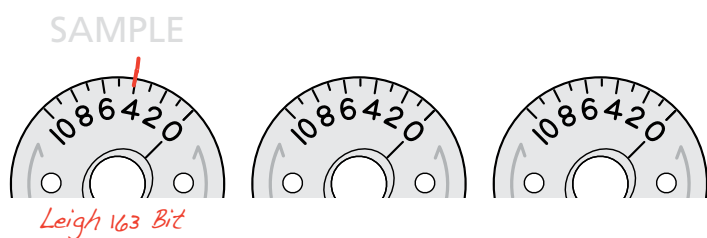

**13-18** On the eBushes above, record the settings you used to achieve perfect joint fit. The first eBush is an example of how to record your setting.

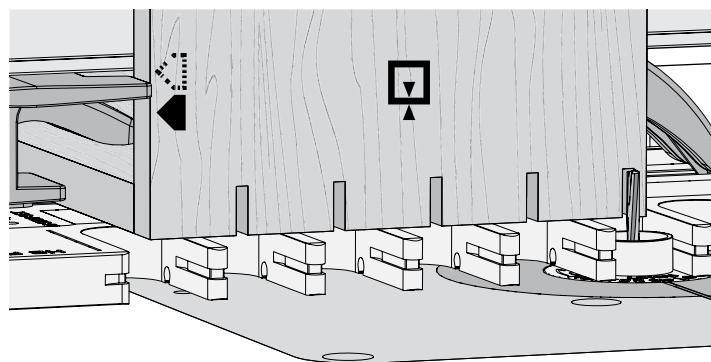

**13-19** Now that your joint tightness has been determined, with the frame pin in position 1, re-clamp pin board 1. Rout in and out of each template opening. ⚠ The eBush must touch one side of the opening as you enter and the other side as you exit.



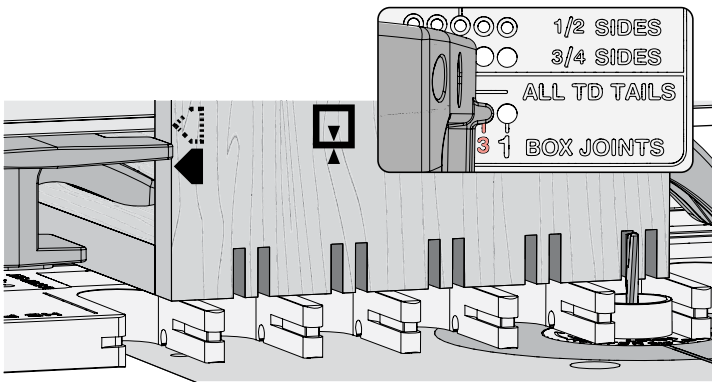

**13-20 Leave the board in place.** Unlatch the frame and move the right frame pin to position 3. Rout in every template opening.

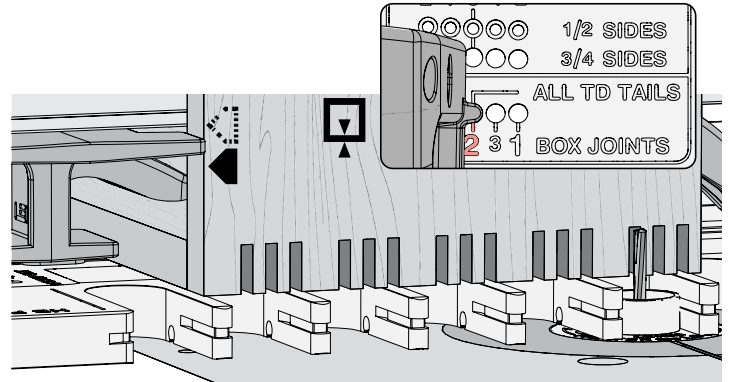

**13-21 Leave the board in place.** Unlatch the frame and move the right frame pin to position 2. Rout in all openings.

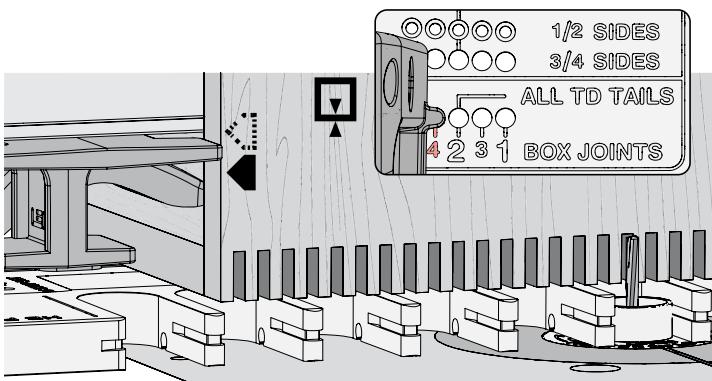

**13-22 Leave the board in place.** Unlatch the frame and move the right frame pin to position 4. Rout in every template opening. Unclamp and flip the board, keeping the same edge against the side stop. Clamp the board. Repeat the steps in reverse order. Remove pin board 1. Repeat procedure for pin board 2.

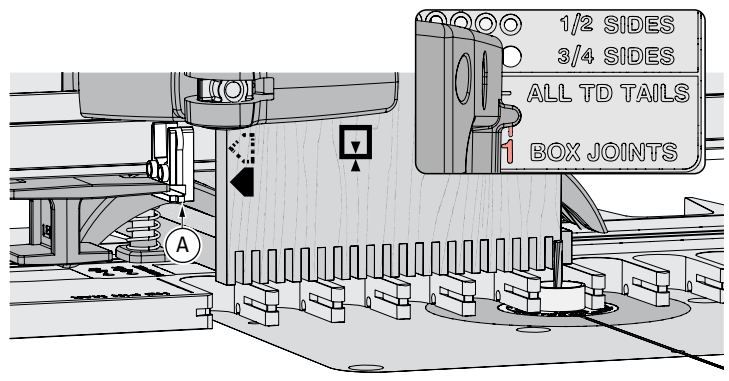

**13-23 Leave pin board 2 in place and do not unlatch the frame.** Loosen the side stop and move it away from the board. **Note: The right frame pin should already be in position 1.** Attach one of the blockers to the side stop. Make sure the blocker is seated firmly against the side stop (A).

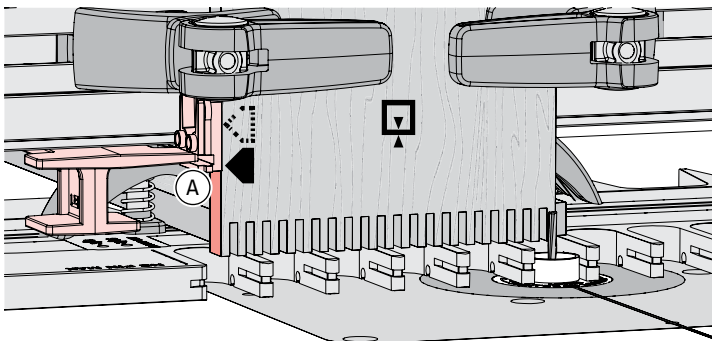

**13-24 Leave the board in place.** Move the side stop, with the blocker attached, against the board and tighten it (A).

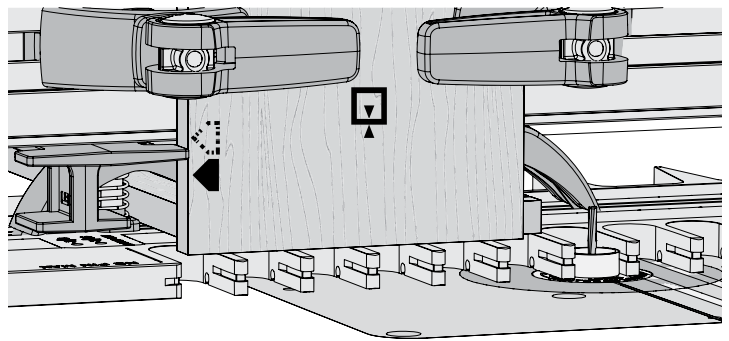

**13-25 Remove the routed pin board and the blocker.** Clamp socket board 1 against the repositioned side stop with its bottom edge flush on the template.

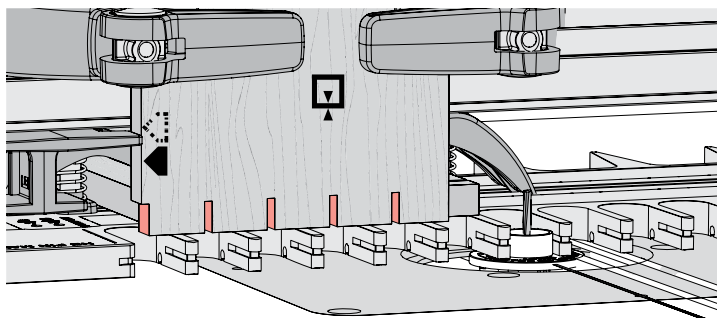

**13-26** Rout in and out of each template opening.

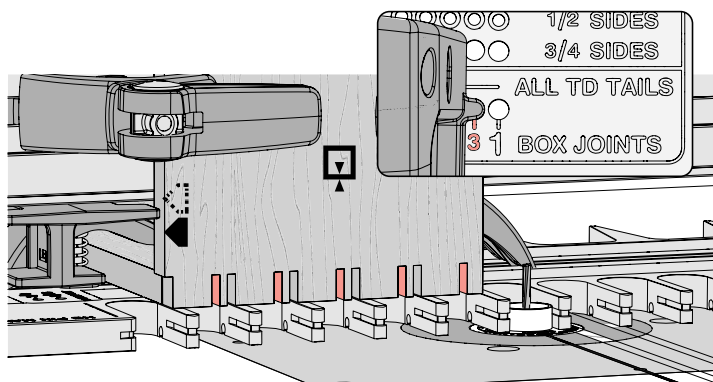

**13-27** Leave the board in place. Unlatch the frame and move the right frame pin to position 3. Rout in every template opening.

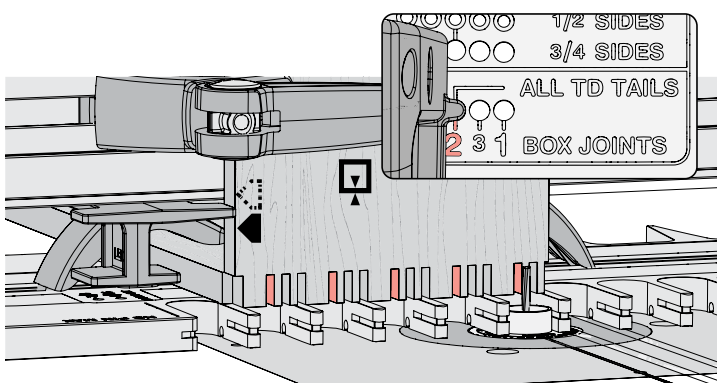

**13-28** Leave the board in place. Unlatch the frame and move the right frame pin to position 2. Rout in every template opening.

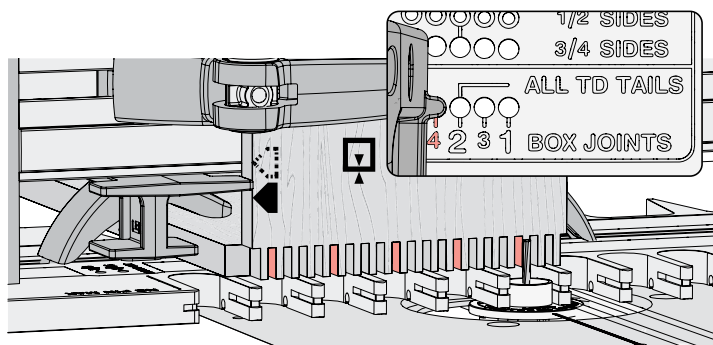

**13-29** Leave the board in place. Unlatch the frame and move the right frame pin to position 4. Rout in every template opening. Unclamp and flip the board, keeping the same side edge against the side stop. Clamp it and repeat the steps in reverse order. Remove socket board 1. Repeat the procedure for socket board 2. Remove socket board 2. All boards are now complete and ready for assembly.

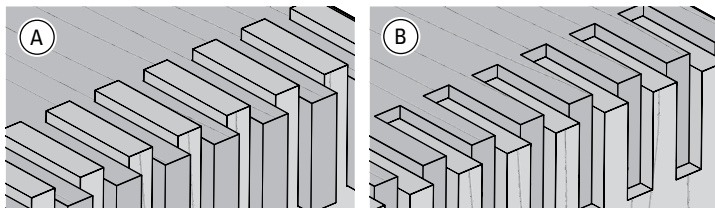

OVER FLUSH

UNDER FLUSH

**13-30** If the joint is over flush (A), lower the bit to suit. If the joint is under flush (B), raise the bit to suit. Rout a fresh test joint until fit and flushness are perfect before routing the actual workpieces. ■