

# Leigh Hold-Down Surface Clamps



## Surface Mount

The simple mounting procedure for Leigh Surface clamps makes them ideal for custom jig and fixture applications as well as bench top use.

- 1.** Drill a 1 1/2" flat bottom hole 5/16" deep. Use spade, saw tooth or Forstner bit.



- 2.** With the anchor in place, use the two large holes as guides and drill two 9/32" holes through the bench top.

- 3.** Countersink the two 9/32" holes from the bottom.

- 4.** Rotate the anchor and use two 1/4"-20 screws (supplied) to secure anchor from the bottom. **NOTE:** If bench thickness prevents securing the anchor from the bottom, two #8 wood screws may be used from the top.

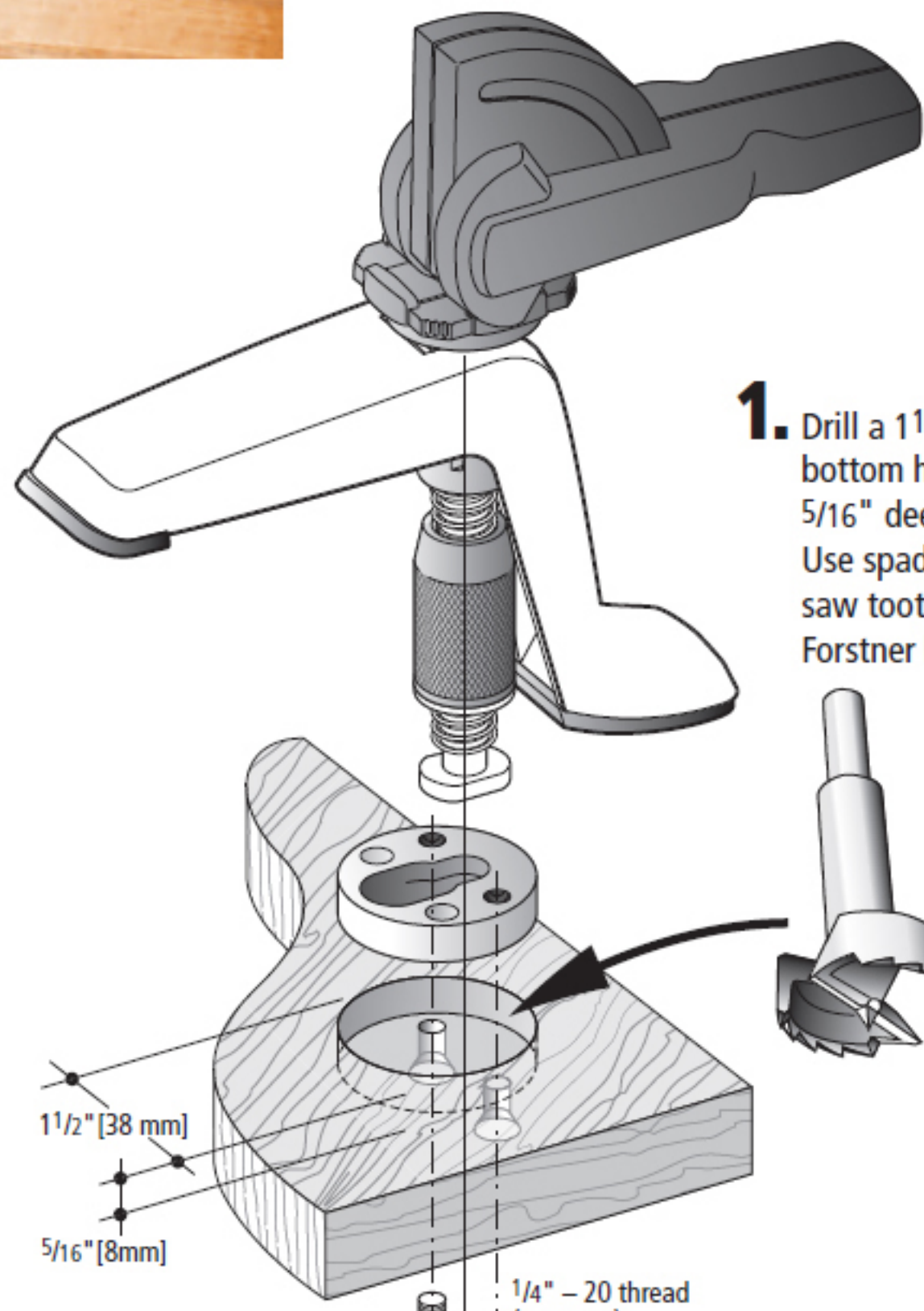
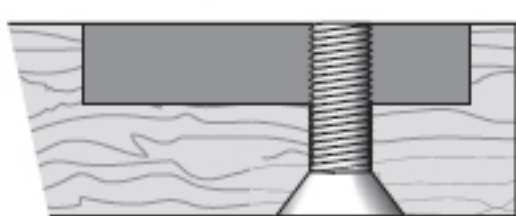

1 1/2" [38 mm]  
5/16" [8mm]

1/4" - 20 thread (common)

1/4" [6mm]

1/4" [6mm]

**NOTE:**  
The center line of the T-Bolt must be 3 3/4" from any obstruction to allow free movement of the clamp.

T-Bolt center line

