

# SUPERJIG - CHAPTER 13 Sliding Dovetails



Watch the Online  
Instructional  
Video



Scan QR Code

**Reduce your learning time dramatically!** Stream to your smart phone or tablet to use in your workshop while you're working. See Instructional Videos section in Support menu at [leightools.com](http://leightools.com) or scan QR code for instant video.

**1** With the Finger Assembly in **HALF-BLIND DOVETAIL TAILS (HB TAILS) mode**, install the cross-cut fence

Sliding Dovetail slots are cut across the board face.

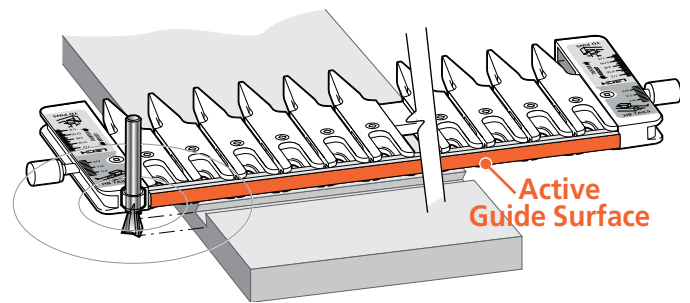
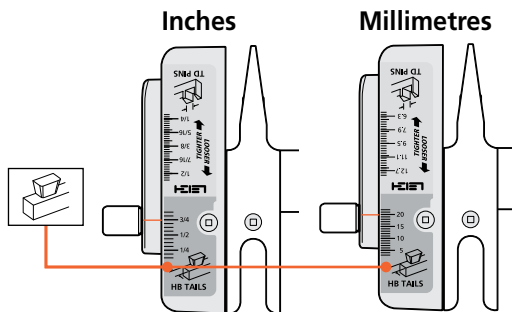

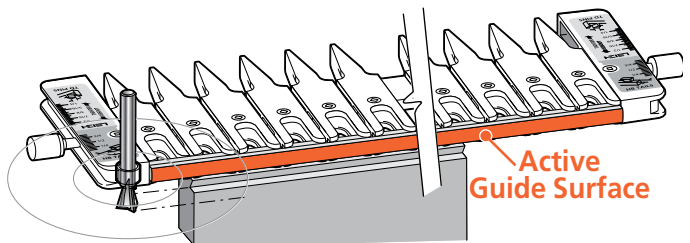
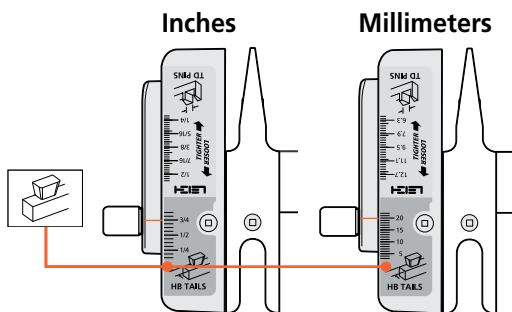

**2** KEEP the finger assembly in the same mode

**3** Sliding Dovetail tails are cut across the board end edge

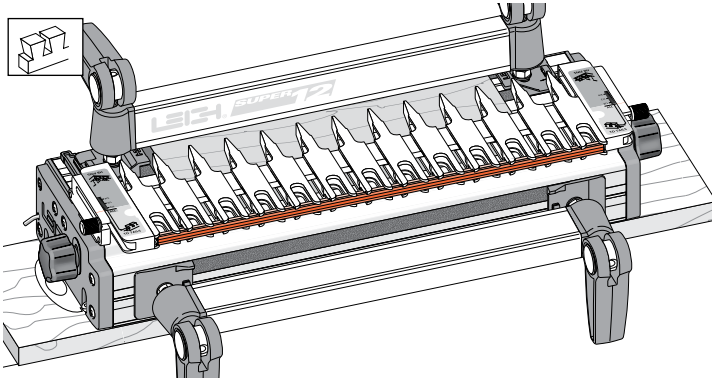



**13-1** With the finger assembly in the  HB TAILS mode, the cross cut fence fits into the recesses in the ends of the tail guides to allow routing of sliding dovetails.

 Space the guides fairly evenly across the jig and firmly seat the fence into end of each guidefinger to ensure a straight cut.

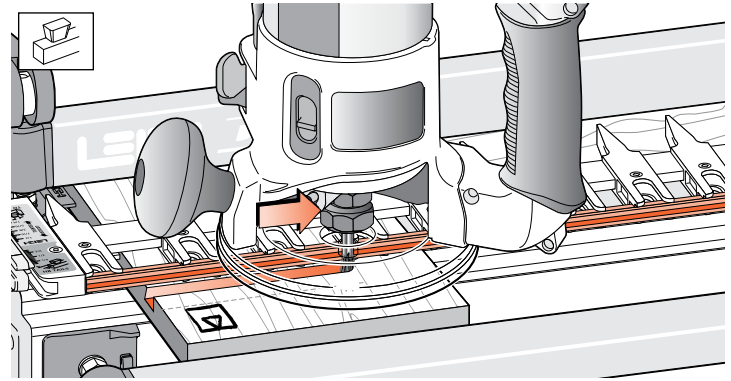

**13-2** Using the cross cut fence as a guide surface for the guidebush, you can make lateral router cuts across the faces of horizontal boards (dovetail *slots*), and...

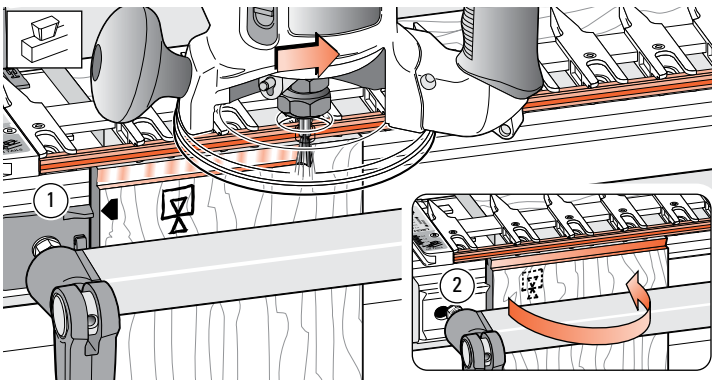

**13-3** Across the top ends of vertical boards to cut the tails. First rout one side ①...

Then turn the board side-over-side to cut the other half of the tail ②.

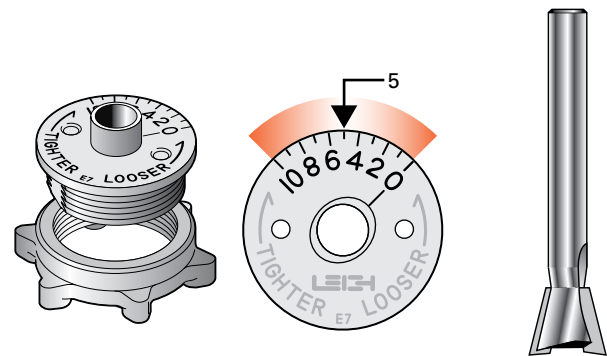

**13-4** Turn the e7-Bush to “5” and use the No. 120-8, ½" x 14° bit for sliding dovetails. This e7-Bush setting will allow for fine fit adjustment later.

A standard 7/16" [11,1mm] guidebush (min. depth ¼" see page 67) can be used but without the fine adjustment provided by the e7-Bush.

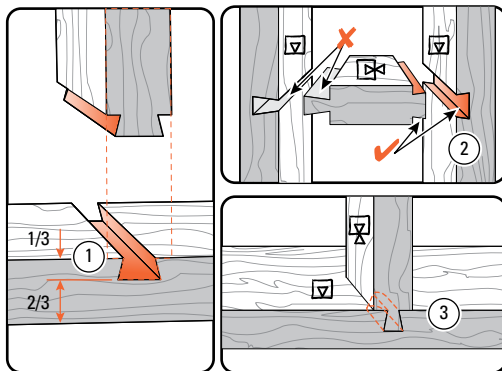

**13-5** On a full width joint, the slot depth-of-cut should be no more than 1/3 the board thickness ①. If the tail board is a load-bearing horizontal member (e.g., bookshelf or step), make the tail fairly thick for good tail neck strength ②. Shorter sliding dovetails for less structural demand may be slightly deeper, with narrower profiles, especially if appearance is important ③ (e.g., where narrow rails join wider boards).

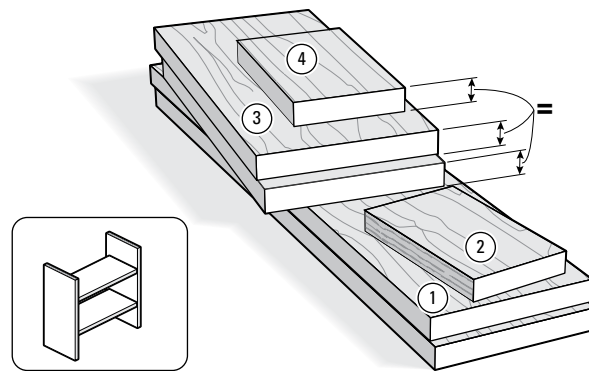

**13-6** Use ¾" x 5½" [20x140mm] softwood to make two slot boards ①, plus one narrow test slot board ②, two tail boards ③ and one narrow test tail board ④. The tail boards ③ and test tail board ④ must be exactly the same thickness. This will make two uprights and two shelves.

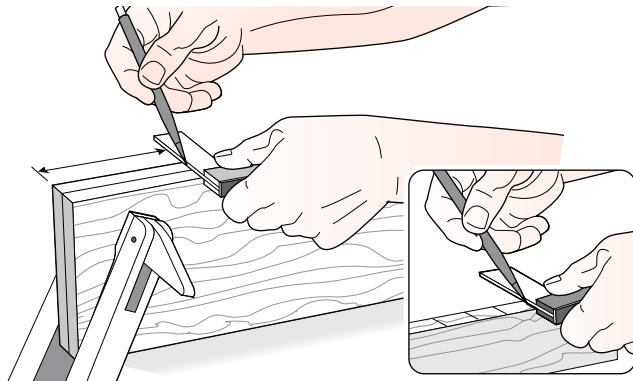

**13-7 Marking Out:** Do not mark the slot positions on the board faces, Mark the edges of both slot boards together for perfectly level shelves. Stay at least 7" [180mm] in from the ends for clamping on this test project. 13-25 describes how to rout close to both ends. Mark the narrow test slot board in the same way at several closely spaced random spots. This board is used only for setup.

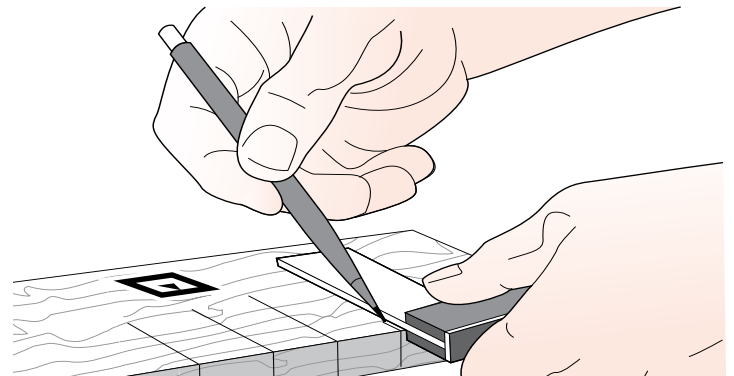

**13-8** On the test slot board only, square the marks across the face.

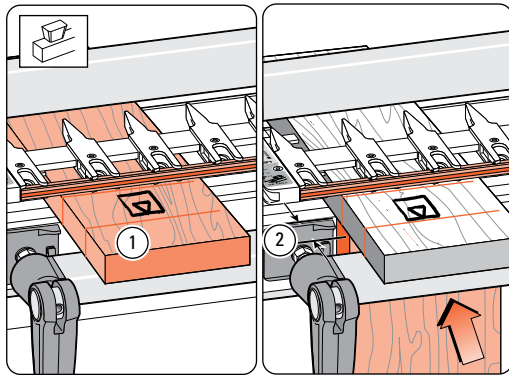

**13-9** Mount the test slot board in the rear clamp, markings up ①. Mount a 3/4" [20mm] thick ② square-ended board vertically in the front clamp against the side stop, with the top edge butting the underside of the test board (yes, the 3/4" [20mm] thickness is important).

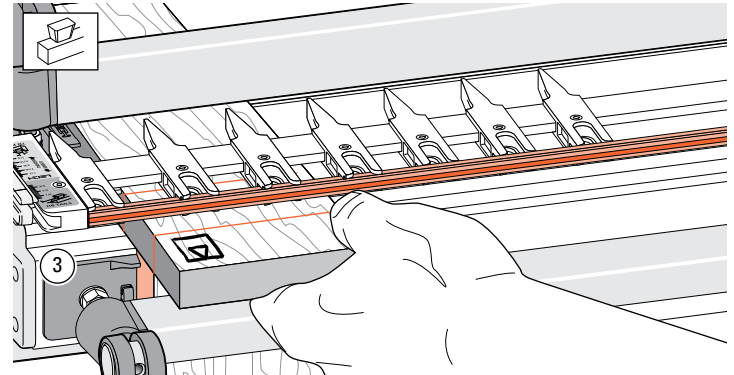

**13-10** Position and clamp the test board so that one of the edge marks is in line with the outside edge of the vertical board ③.

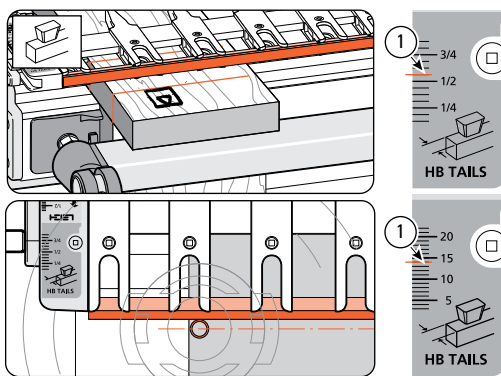

**13-11** With the finger assembly (including the cross cut fence) on the support brackets in the HB TAILS mode, set the scale to 3/16" [14mm] ①. The routed slot will be close to centered on the slot line. Make sure the finger assembly is level and sitting flush on top of the board.

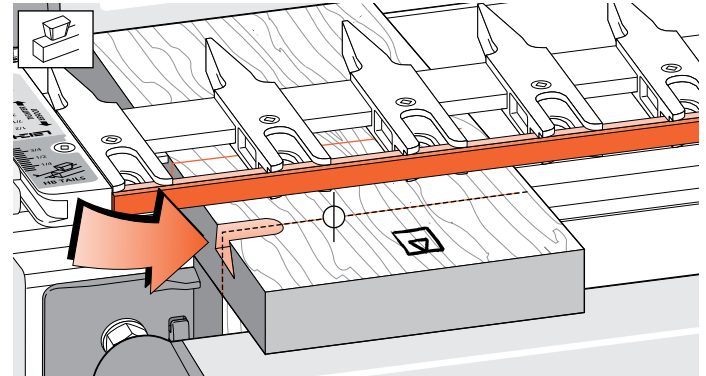

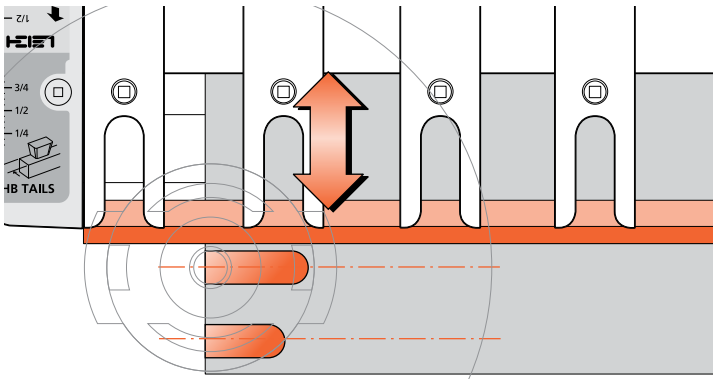

**13-12** Adjust the bit so the cut depth is about 5/16" [8mm]. Rout from left to right maintaining light inward pressure of the guidebush on the fence. Rout in only about 1" [25mm] and back out again.

 Do not lift the router.

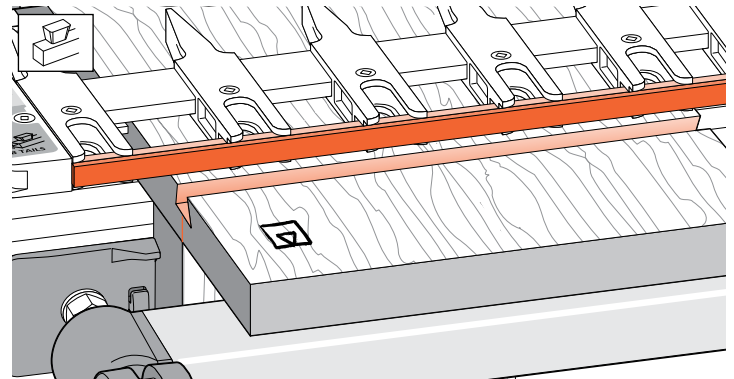

**13-13** Check to see if this short slot is centred on the pencil line. If not, adjust the finger assembly in or out and re-test on the other lines as necessary until the slot is centred. Lock the finger assembly in this position and record the setting for future reference.



**13-14** Now rout sliding dovetail slots in the two main slot boards with the boards in the horizontal position in the rear clamp, slot side, that is inside face  up. The guidefingers must be flush on the board.

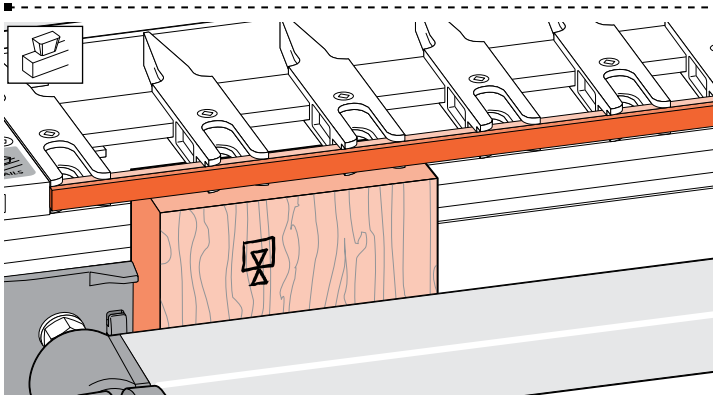

**13-15** Replace the spacer board in the rear clamp, and with the finger assembly on the spacer board, mount a test tail board vertically in the front clamp, flush under the guidefingers. Either side can face out .

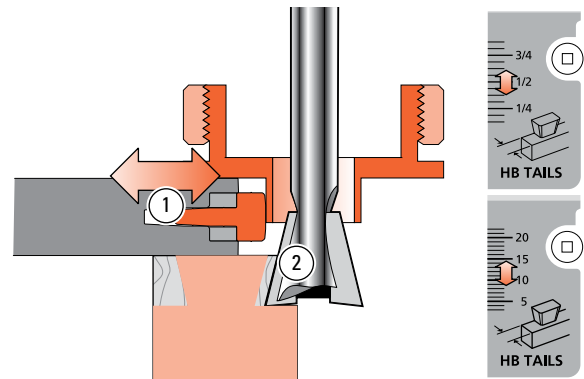

**13-16** The  HB TAILS scale is not designed for this mode, but it does allow you to make quick adjustments for tail size and joint fit on sliding dovetails. Adjust and set the finger assembly ① so it is clear that the routed tail ② will be too large for the slot.

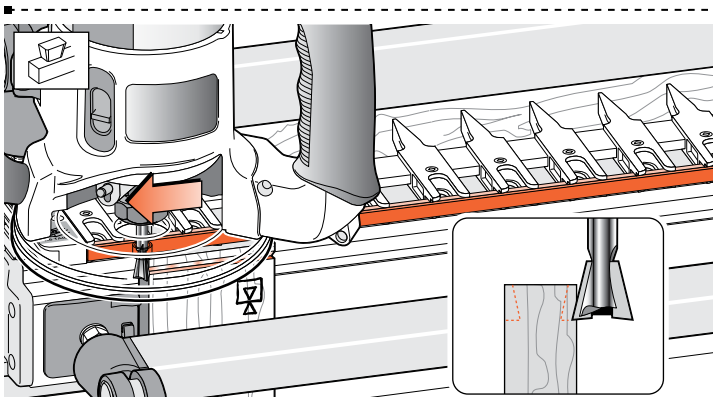

**13-17**  Rout one side of the test tail board. Make one light pass from right to left (climb routing). Make sure you control it firmly, because it is driven in this direction by the bit. Only the tip of the bit should be cutting on the first cut (see inset). This *back* or *climb* routing leaves a very clean shoulder in side grain.

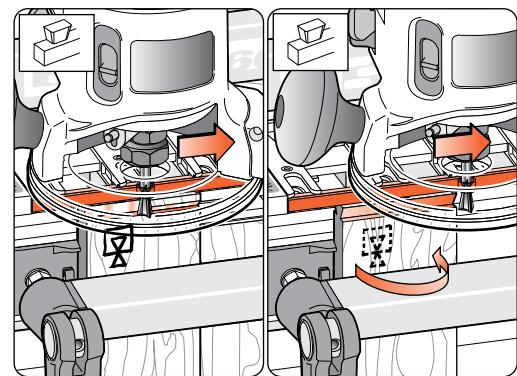

**13-18** Finish left to right, with the guidebush touching the fence. Turn the test tail board around in the jig and rout the other side in the same manner.

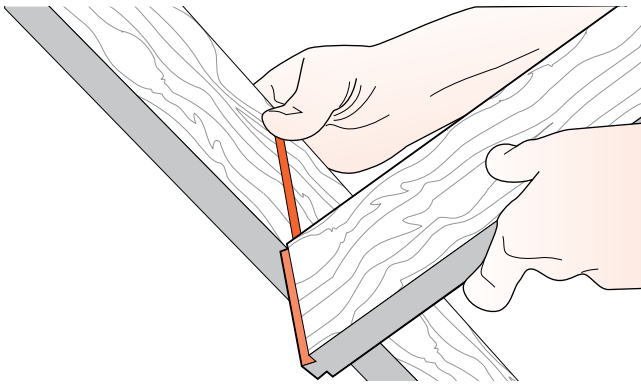

**13-19** Test the joint for fit. The tail should be too big. If it is too small, adjust the finger assembly outward by at least half the difference and rout another test tail on the other end of this test board.

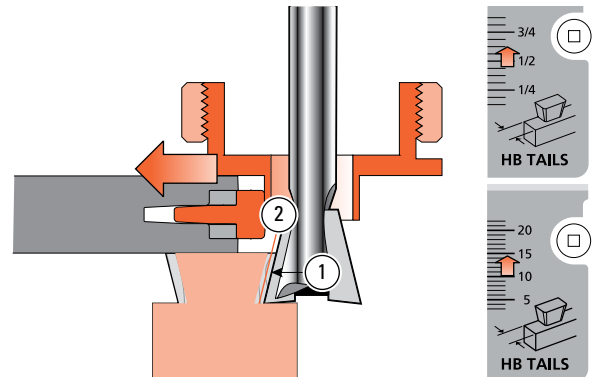

**13-20** If the tail is too wide ① move the finger assembly in toward the jig by half the amount the tail is too wide ②. Rout the same test board again. Adjust and re-test until fit is slightly loose or slightly tight.

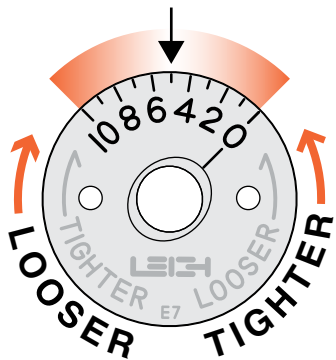

**13-21** Note: the e7-Bush fit adjustment for sliding dovetails works reverse to normal. Fit adjustments are made by adjusting the tail size only, not the socket. The e7-Bush is turned down to a lower number for a tighter fit, and up to a higher number for a looser fit. Each increment changes the glue line fit by 0.001" [0,025mm] When the fit is satisfactory, rout one end of a project tail board and test again. If the fit is good, rout all tail board ends.

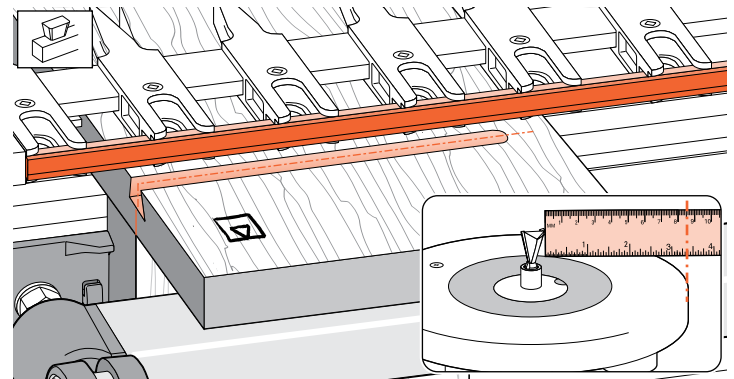

**13-22 Stopped Sliding Dovetails**

If a stopped sliding dovetail is called for...

Measure from the outside tip of the dovetail bit to the edge of the router base.

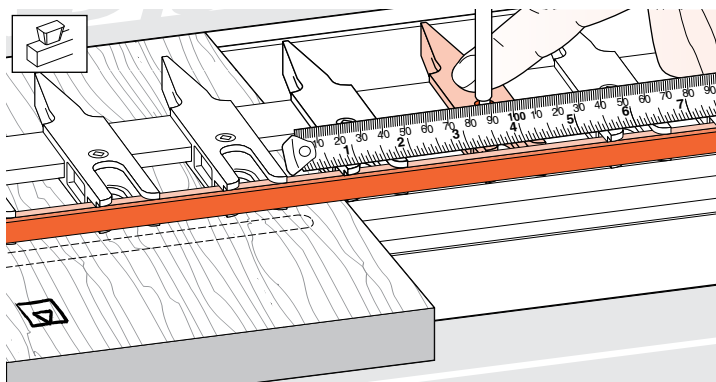

**13-23** Measure the same distance from where you want the slot stopped to a position on the finger assembly. Move a guidefinger to that point and mark the guidefinger with a felt pen as a visual router stop mark...

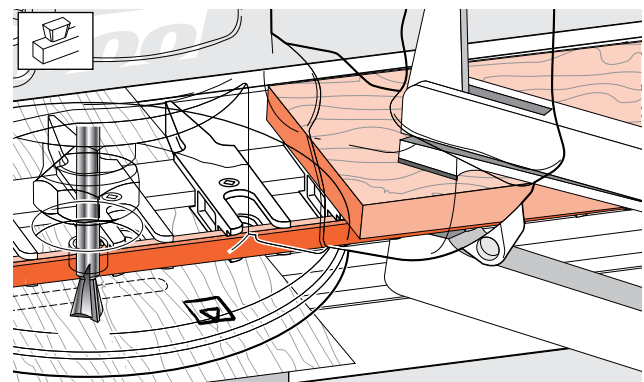

**13-24** Or lightly clamp (with a soft-jawed clamp) a short board to the finger assembly to act as a router stop.

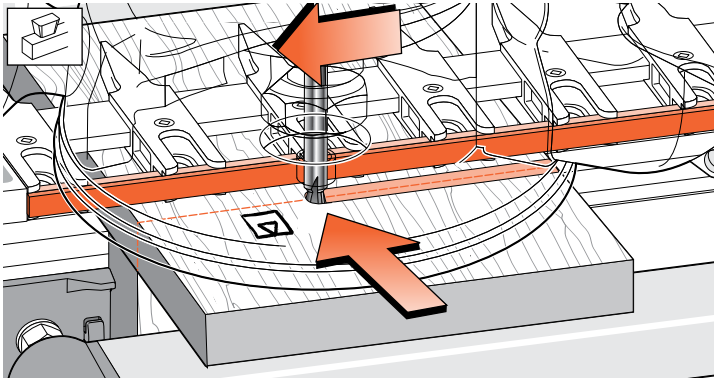

**13-25** ⚠ Dovetail slots preferably are routed from left to right because the bit's clockwise rotation pulls the guidebush against the fence. However; as when routing close to both ends of a board, it may be necessary to rout slots from right to left. **Bit rotation** will tend to pull the router away from the fence. Feed slower and maintain constant guidebush pressure against the fence. ■

---