



Watch the Online Instructional Video



Scan QR Code

Reduce your learning time dramatically! Stream to your smart phone or tablet to use in your workshop while you're working. See Instructional Videos section in Support menu at leightools.com or scan QR code for instant video.

SUPERJIG - CHAPTER 1

Jig Assembly, Mounting, and Using the Clamps

Make Sure You Have All the Parts.

Before you start to assemble your Leigh SUPERJIG, check to make sure you have received all the required parts.

The small carton you removed from the end of the main carton contains:

1. 2 support brackets
2. 4 cam-action speed clamps
4 cam clamp pivot nuts
3. 1 e7-Bush & Nut with Pin Wrench
2 each, front and rear Side Stops
1 Spacer
4. 2 support knobs
5. 4 clamp springs
4 clamp T-bolts
4 flat washers
4 T-bolt nuts
4 Jig Hold-down Wood Screws No.10 x 1"
6. 2 scale thumbscrews c/w nylon washers
7. 2 Dovetail bits, 1 straight bit, 1 Collet Reducer
8. Square-head guidefinger screwdriver

Also included are any other small optional items you may have ordered with your new jig. Check the packing slip for this information.

The main carton contains:

9. 1 main jig body
1 Leigh jig User Guide
Warranty/Registration Card

The large inner box contains:

10. 1 finger assembly on a bar, complete with scales
Super12, with 13 guidefingers
Super18, with 16 guidefingers
Super24, with 19 guidefingers
2 lengths bridge material – see Chapter 9
1 crosscut fence (same as bridge) – see Chapter 13
2 clamp bars c/w end plugs
1 Nylon Stop Rod – see Chapter 10
1 Quick Reference pull-out card

If any items are missing from your jig, contact your supplier or Leigh Industries immediately.

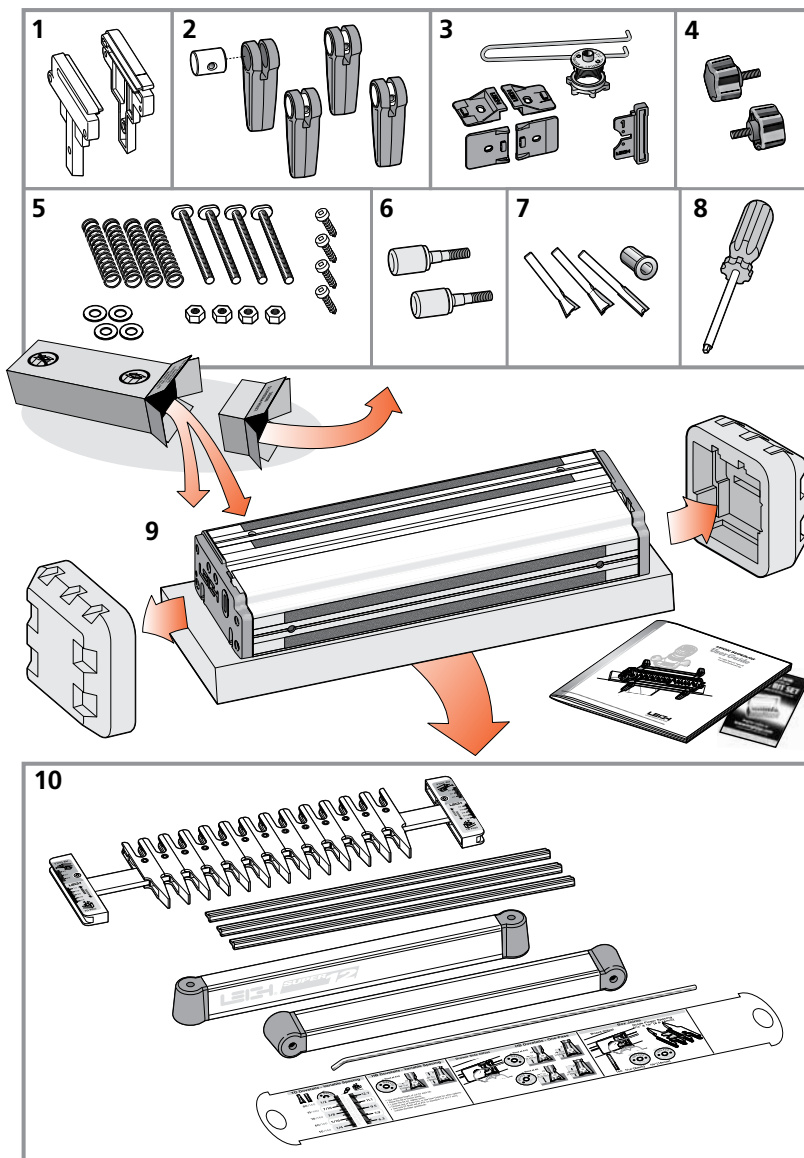

Important Note

Mount your jig securely, assemble it completely, and make sure you have read and understood the Safety section of this user guide before using the jig.

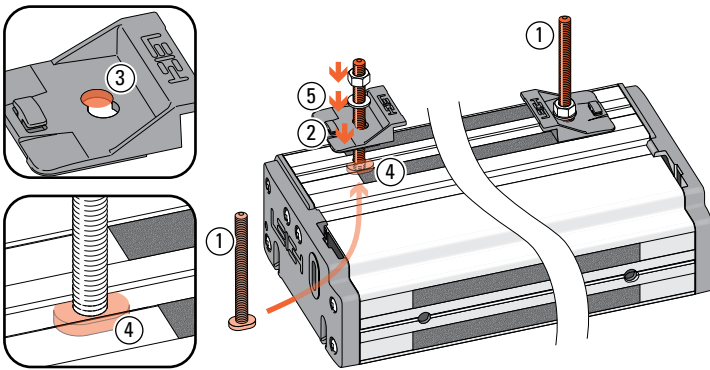

1-1 Install Side Stops Insert two clamp T-bolts through the rear jig body holes ① and place a “stepped” rear side stop over each bolt ②, using the rear part of the double-hole ③. Make sure the bolt’s “T” is between the extrusion ribs ④. Don’t forget the steel washer ⑤ and use a ½" [13mm] wrench to tighten the nuts.

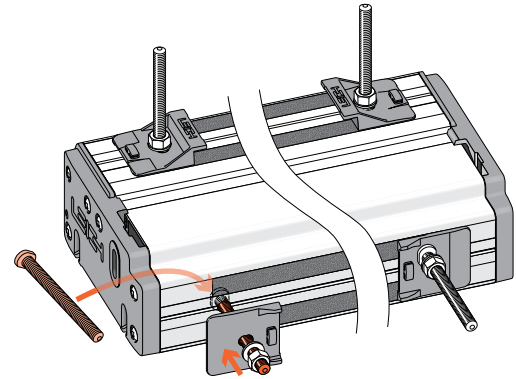

1-2 Insert the two front clamp T-bolts through the jig body holes. **Make sure the bolt’s “T” is between the extrusion ribs.** Place a front side stop and steel washer over each bolt but **only finger-tighten the front nuts**; you will need to index these to the rear stops later.

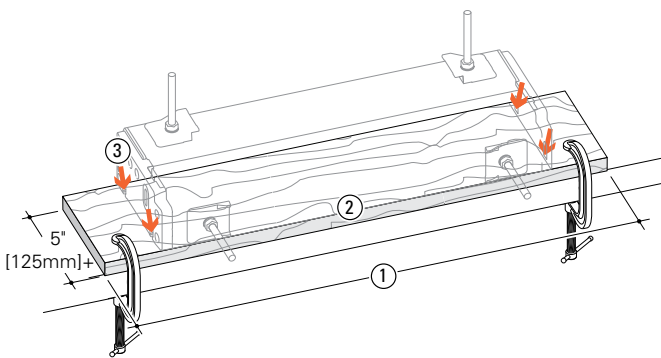

1-3 Prepare a flat ¾" [20mm] mounting board (plywood or MDF), at least 5" [125mm] wide. Length ①: 26" for Super12, 32" for Super18, 40" for Super24 [660, 830 or 1000mm respectively]. Clamp it to the front of your bench. Center the jig on the board, front face slightly overhanging the board edge ②. Mark the four hold down screw positions. Drill small pilot holes at a slight angle ③.

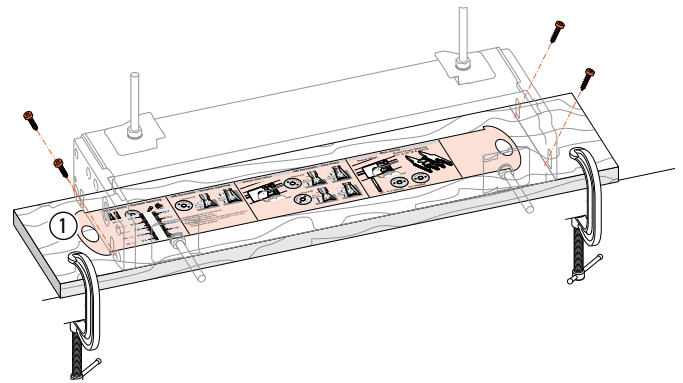

1-4 Quick Reference Pull-Out Decide which end of the jig you wish to access the “Quick Reference” instruction pull-out and place the jig over the pull-out ①. Using the screws provided; screw the jig to the board. Make sure that the pull-out slides freely.

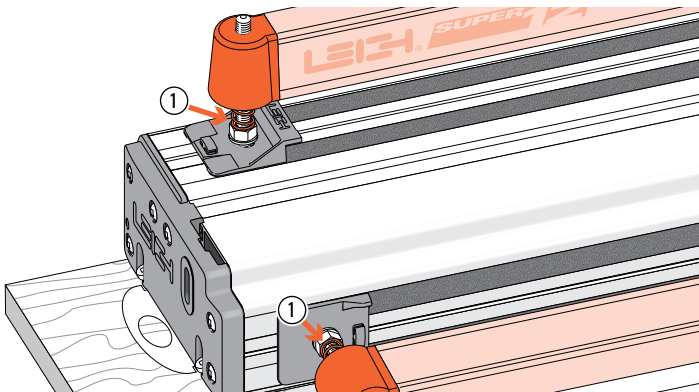

1-5 Place four springs ① and two clamp bars on the T-bolts. Make sure the clamp bars move freely on the T-bolts.

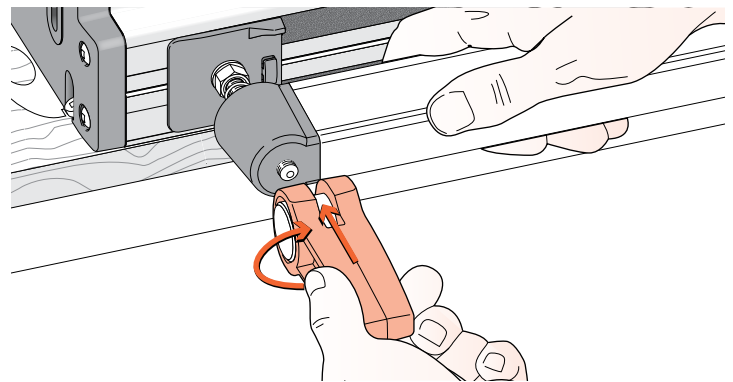

1-6 Screw a clamp lever assembly onto each T-bolt.

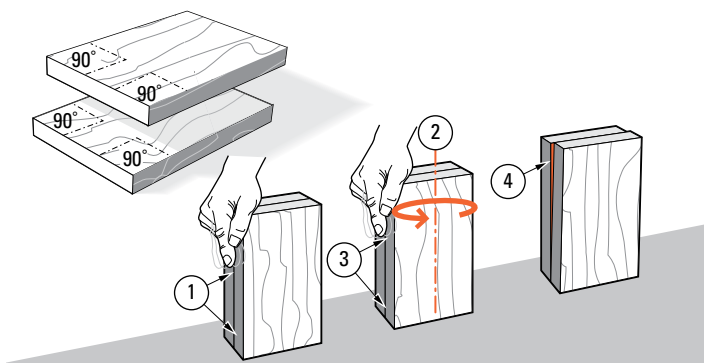

1-7 Now you need two boards about $\frac{3}{4}$ " x 6" x 8" long [20 x 150 x 200mm]. Both must have perfectly square ends to accurately index the front and rear side stops.

 Check for squareness: stand both pieces vertically on a flat surface. Make sure side edges are flush at bottom and top ①. Turn one piece around on its end ②. If side edges are flush top to bottom ③, the boards are square. If not, ④; cut two that are.

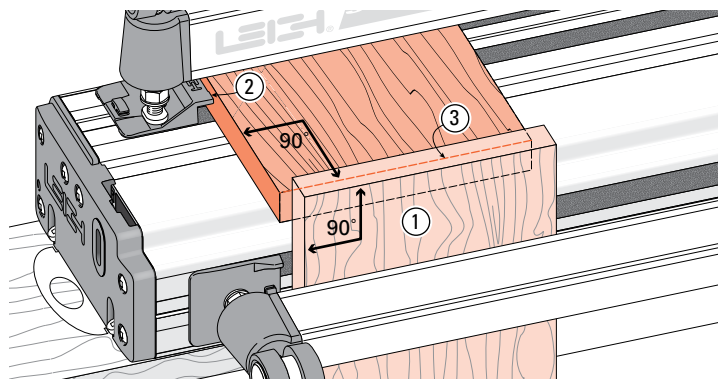

1-8 Align Front Side Stops Clamp one square ended board in the front, not touching the left side stop and with the top edge above the top surface of the jig body ①. Place the other square board in the rear clamp, tight against the left rear side stop ②, with its front edge touching flush across the rear of the vertical board ③. Tighten the rear clamp.
Note: Do not overtighten the right hand clamps during this step.

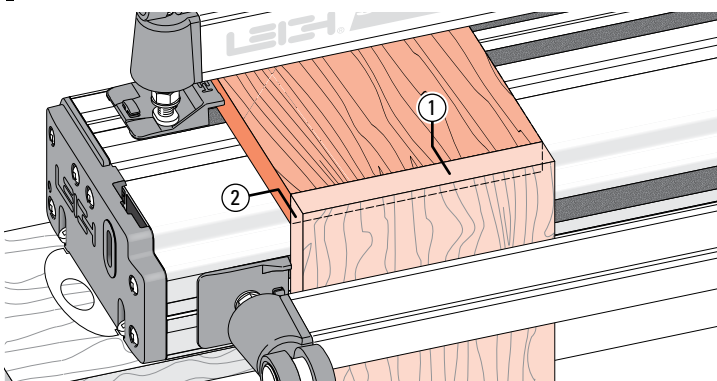

1-9 Now loosen the front clamp and position the front board so its top end edge is perfectly flush and level with the top face of the horizontal board ① and, both boards left edges are also perfectly flush ②. Tighten the clamp.

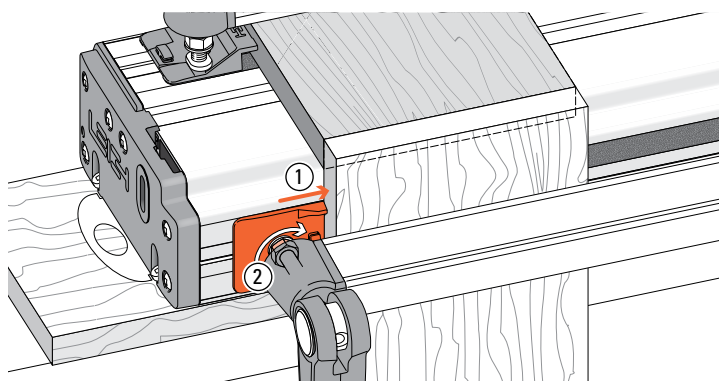

1-10 Now push the front left side stop inwards and flush against the vertical board ① and firmly tighten the clamp bolt nut. Repeat operations 1-8 thru 1-10 at the right side of the jig. The front and rear side stops are now indexed to provide accurate board alignment in all routing procedures. You may now remove the boards.

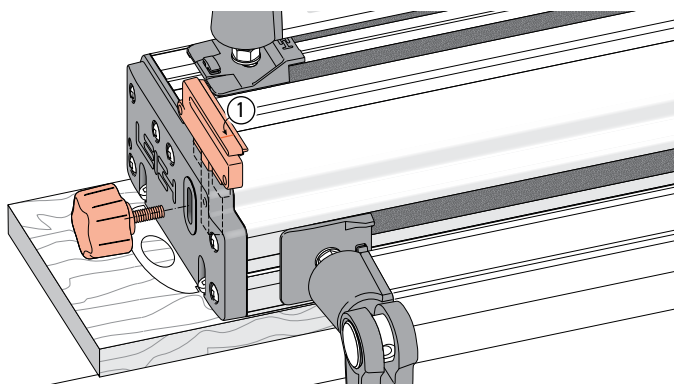

1-11 Insert the right and left support brackets. Attach the knobs, raise them to full height and tighten the knobs.
Note: For clarity, the set lines on support brackets are shown in red in this user guide. The actual bracket lines are black.

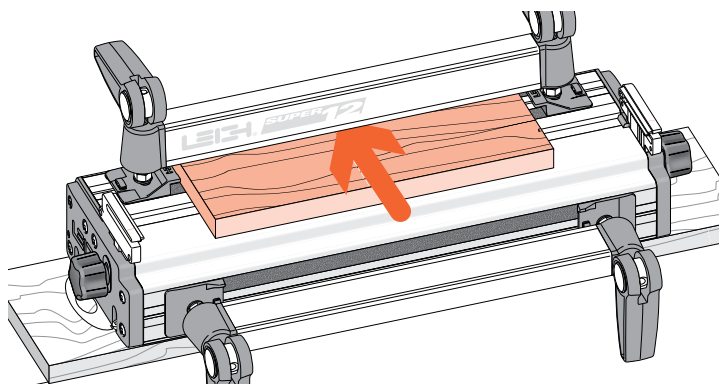

1-12 Make up a spacer board. This will be used to support the finger assembly in all front-clamping vertical board modes. Use MDF or plywood for flatness and stability. We suggest $\frac{3}{4}$ " x 6" [20x150mm], in lengths of 11" [280mm] for Super12, 17" [430mm] for Super18, and 23" [600mm] for Super24. **Note:** Thickness of spacer board has no relationship to thickness of vertical board being routed. Clamp board in rear of jig.

IMPORTANT

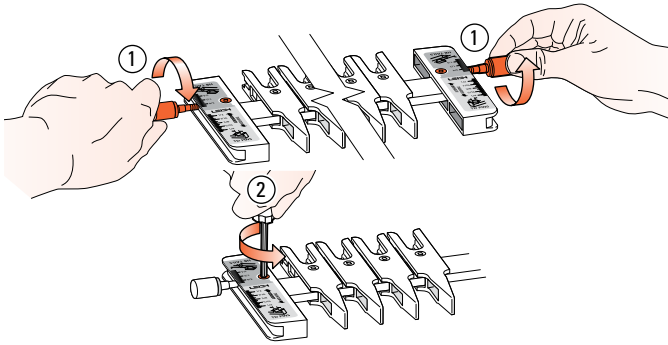

1-13 Before using the jig, the scales must be set into position on the finger assembly. Install the two thumbscrews a few turns into the scales ①. Loosen the scale lock screw ② at each end by one turn only.

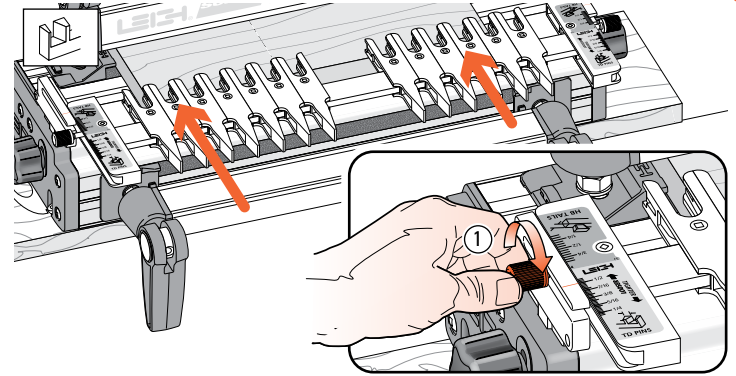

1-14 Slide the finger assembly onto the support brackets, in the TD Pin mode and set on the 1/2" [12,7mm] setting. First, tighten both thumbscrews ①. Do not lower the assembly onto the finger support board.

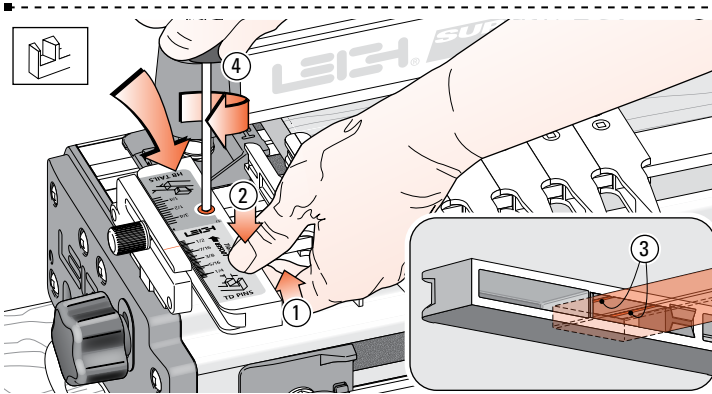

1-15 Pull up on the finger bar ① while pushing down on the scale ② to ensure the bar is touching the two registration pads ③ inside the scale. Maintain pressure and tighten the scale lock-screw ④. Repeat at the other end. To maintain correct finger assembly alignment, follow this procedure whenever you remove the scales from the finger assembly.

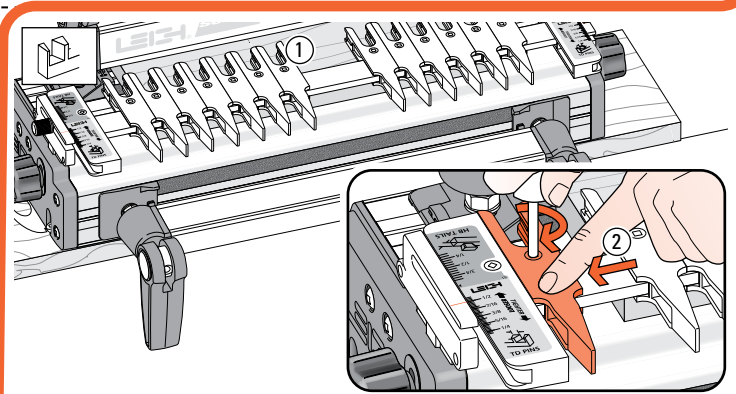

1-16 With the finger assembly in TD Pins mode ①, move the outer end guidefingers to touch the scale block and lock in position ②. Note: the outer end guidefingers are used for router support only. When guidefingers are loosened, the finger assembly should easily slide on the support brackets. If not, apply a little candle wax to the mating surfaces.

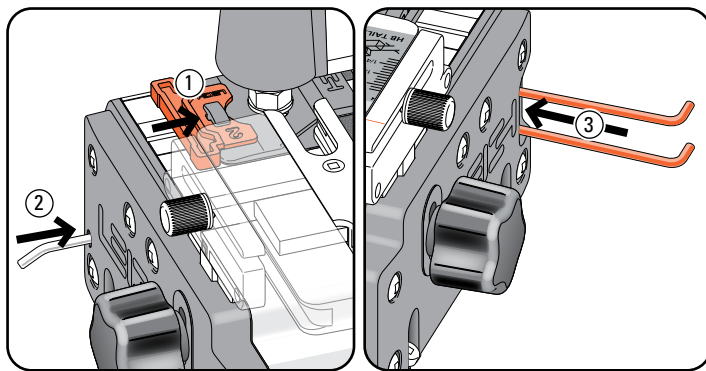

1-17 Finally, slip the Spacer on the outside of the left rear side stop ①, the nylon stop rod through its storage hole in the left end ② and the pin wrench in its slot in the right hand end housing ③.

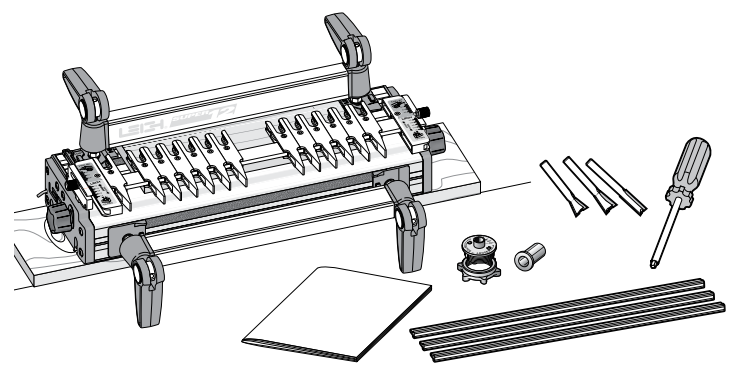

1-18 With Superjig assembled and mounted, you have some items left over:

- 1 Leigh jig user guide
- 1 Leigh e7-Bush and nut
- 2 Dovetail bits
- 1 Straight bit
- 1 Collet Reducer
- 1 square-head screwdriver
- 3 bridge-piece/crosscut extrusions

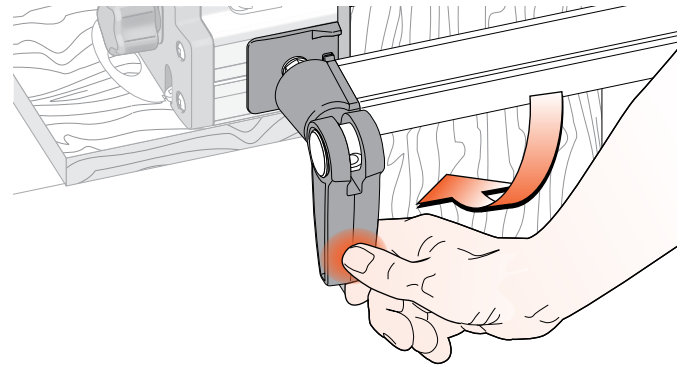
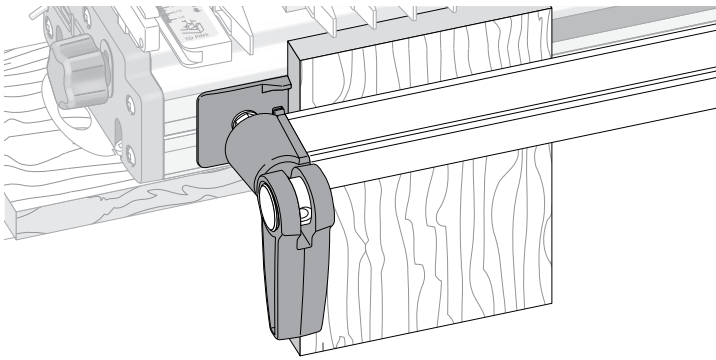

1-19 The Jig Clamps Use a piece of flat, even-thickness wood to familiarize yourself with the jig cam clamps. You will operate the cam-action speed clamps every time you use the jig, so get used to the feel of the clamps first. **Do not force the cam-action speed-clamp.** It has great leverage, and excessive force may damage the workpiece or the jig.

1-20 A smooth, firm action is enough to engage the clamp. Rule of thumb: If you can't throw the lever by pressing the end of it firmly with your thumb, reduce the tension. **Firm thumb pressure is about right.** A few minutes of trial and error will help you feel the right clamp tension.

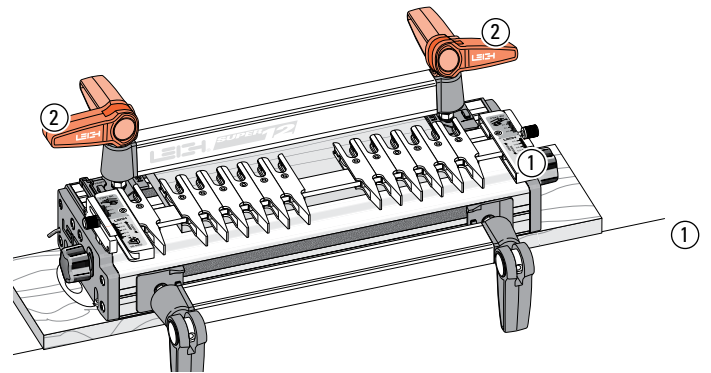
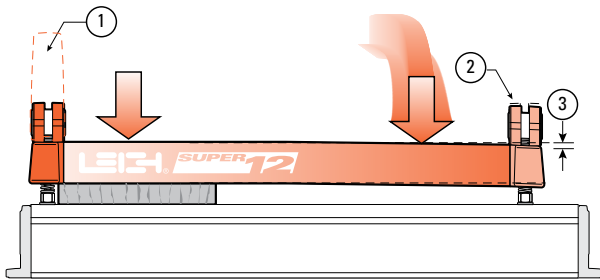

1-21 For all but the wider workpieces, you need only operate the clamp on the workpiece end of the jig to release the board ①. For narrower boards, the clamp at the free end ② should be just tight enough to bow the clamp bar about 1/16" [2mm] ③.

1-22 When engaged, the front clamp levers should normally point down and the rear levers should point away from the operator ① or up to 90° either side ② as required to obtain the optimum clamping pressure.

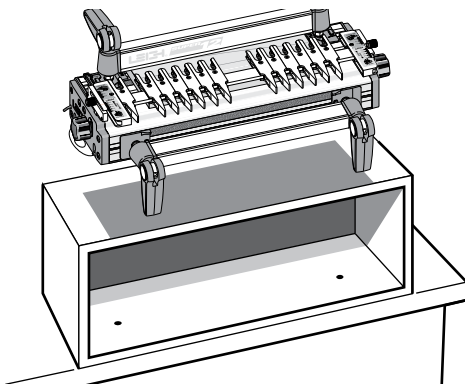

1-23 To gain height for a more comfortable working position or for routing longer boards, mount the jig to a box that can be bolted securely to a bench.

See also 15-13. ■

