

Leigh Hold-Down Bench Clamps

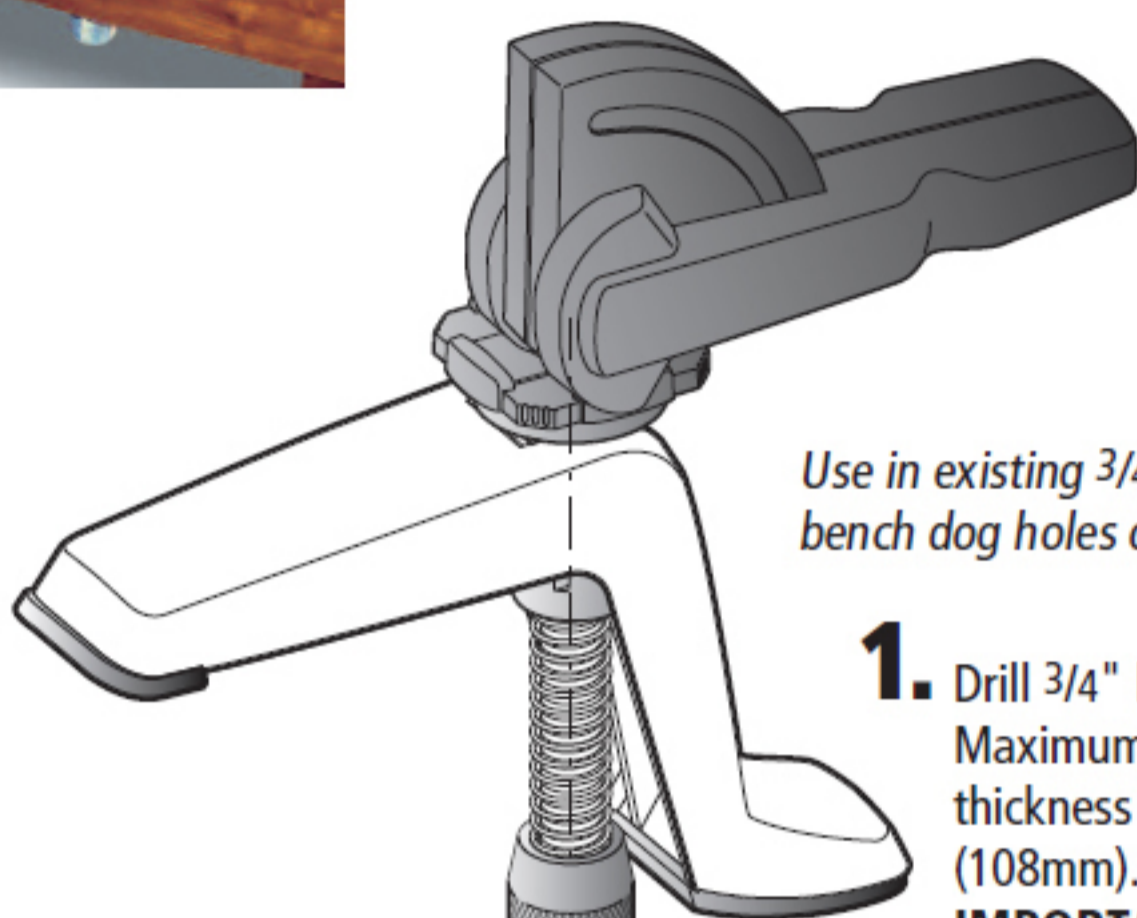

Bench Mount

Bench hold-down clamps mount easily on any flat surface, vertically, horizontally or on an angle. Simply use existing holes or drill your own for precise clamp spacing.



Use in existing 3/4" (19mm) bench dog holes or...

1. Drill 3/4" hole. Maximum bench thickness 4 1/4" (108mm). **IMPORTANT:** Drill at 90° to bench top. Use saw tooth, spade or Forstner bit.

Brass nut held in place with Loctite. Do not move.

3/4" [19mm]

3/8" - 16 thread

Speed nut

2. Slide speed nut along threaded rod until it contacts bottom of workbench. Then twist to tighten.

Mounting Options

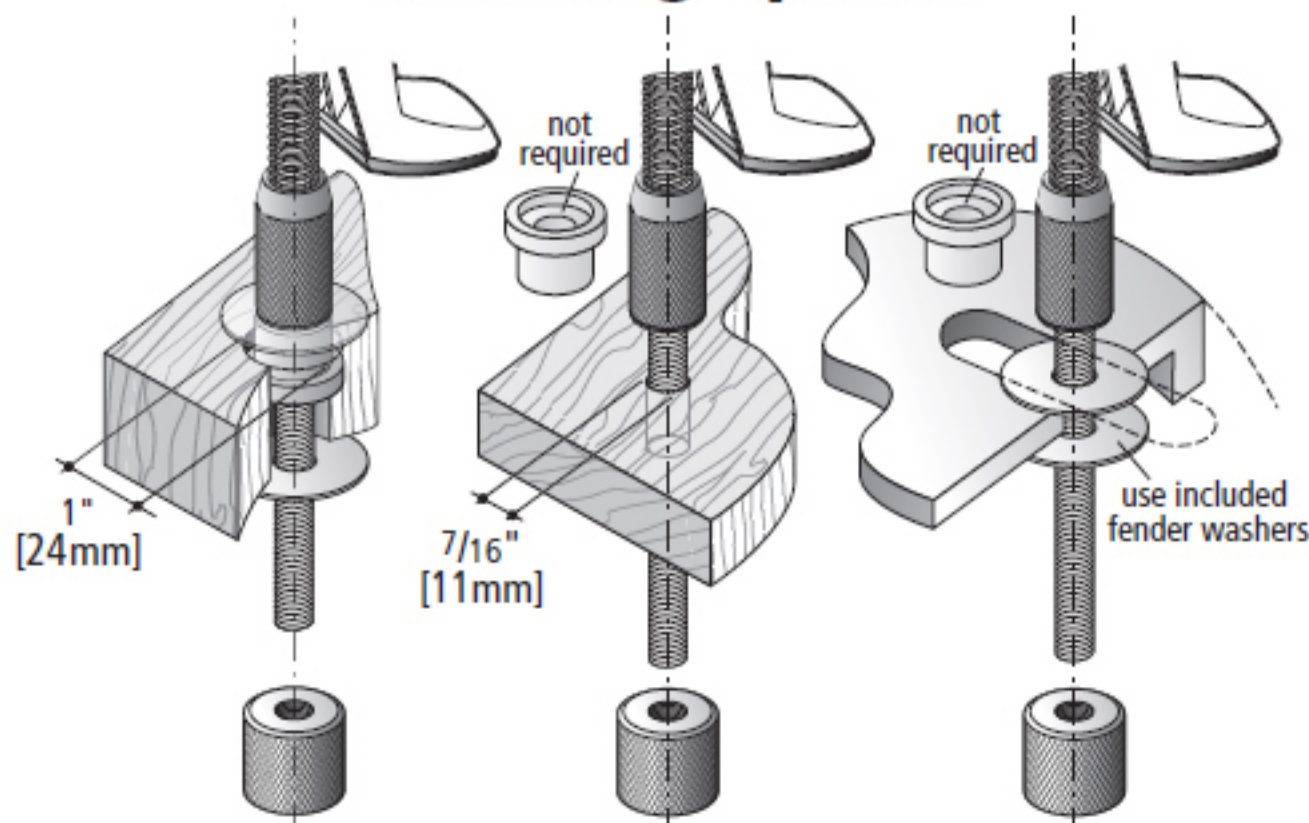

Larger diameter bench hole mount

Smaller diameter bench hole mount

Drill press table mount