

## CHAPTER 7

## Half-Blind Box Joint Procedures

See Page ii for joint sizes.

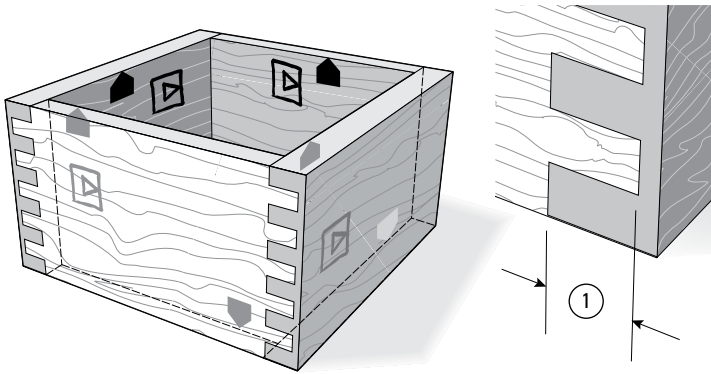

**7-1 Half-Blind Joints** Unlike normal box joints, the inside faces of half-blind box joint boards always face away from the jig body, and alternate edges are placed against the side stop. Set the depth of cut ① to about  $\frac{1}{8}$ " [3mm] less than the drawer-front thickness. Use only the "Symmetrical" board widths for half-blind joints.

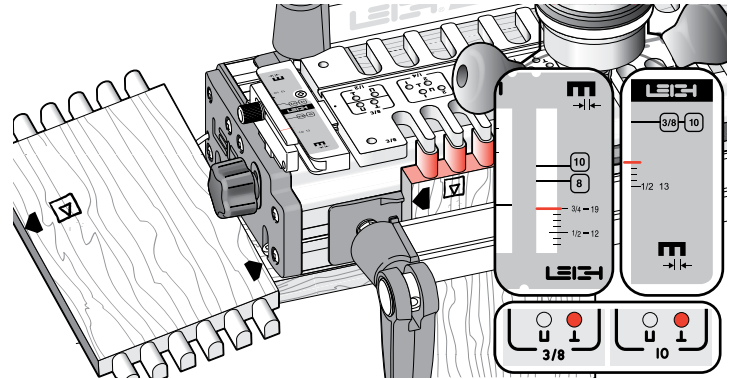

**7-2** Set the template pin on the **L** setting and the scales to the thickness of the box sides, e.g.  $\frac{3}{4}$ " [20mm] shown here. Rout the box side ends vertically in the front clamp.

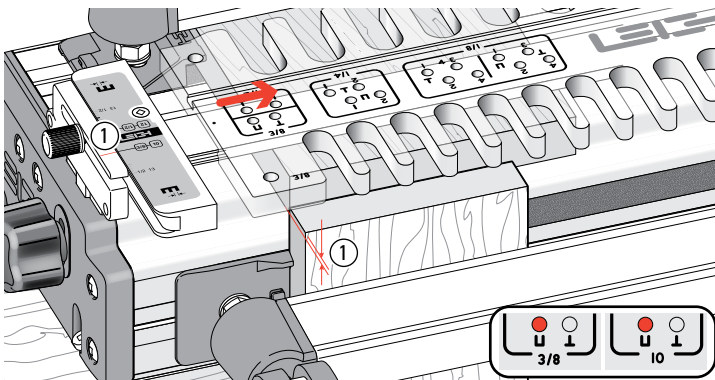

**7-3** Set the template pin on **U**. Clamp a scrap piece vertically in the jig front with its top end slightly above the jig body ①. Clamp a box front horizontally with the inside face **□** away from the jig body, and the front end edge against the scrap board.

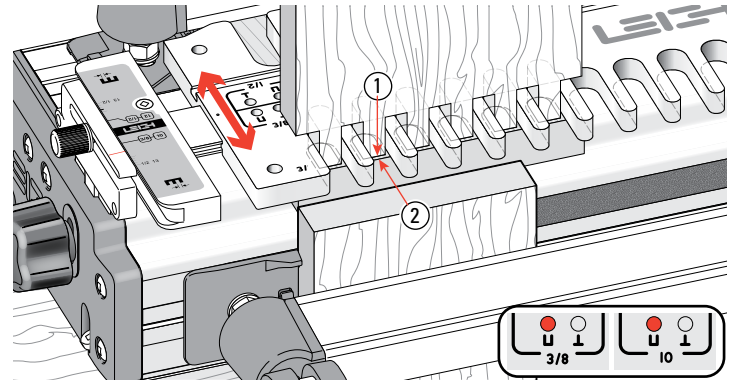

**7-4** Place one of the routed box sides vertically through the template with the rounded part of the fingers in the rounded guide crotches. Adjust the template so the front face of the side board ① is  $\frac{1}{16}$ " [1,5mm] in from the end edge of the box front ②. Lock the scales on the same setting at both ends.

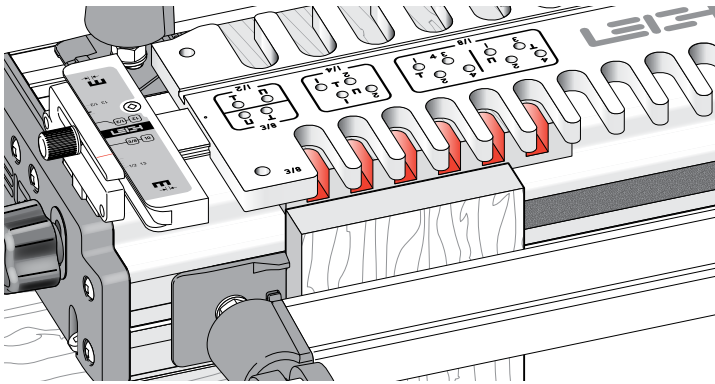

**7-5** Rout a test piece to test the scale setting for joint flushness and adjust the template in or out to produce the required flush fit.

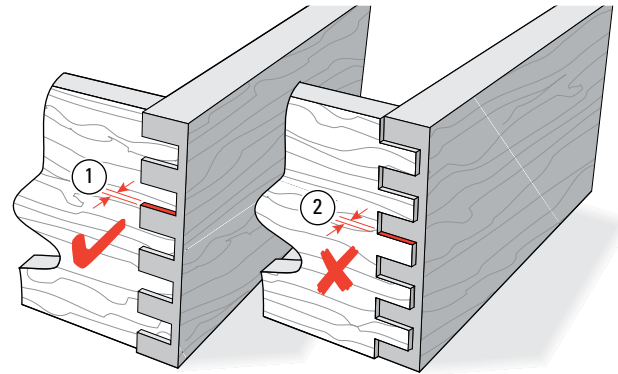

**7-6** The drawer front pins should project through the side sockets by no more than  $\frac{1}{64}$ " [0,25mm] for clean-up ①. If the sides project ②, adjust the template inward to suit.

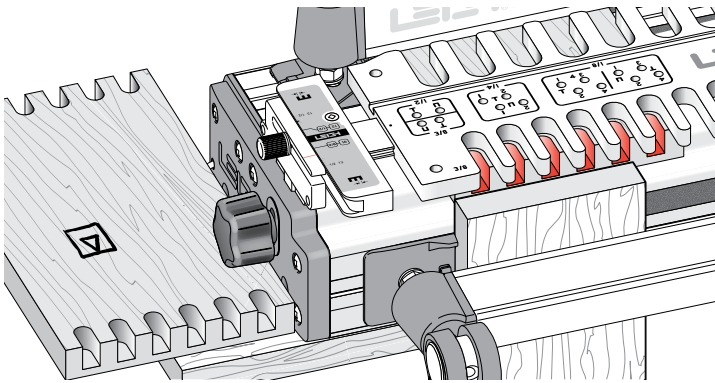

**7-7** When satisfied with the flushness fit, rout all the ends of the box fronts and backs in this mode.

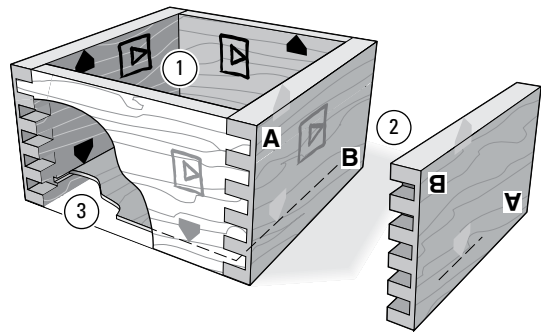

**7-8** Square half-blind box joint boards must be assembled with the inside faces inwards ① but unlike normal box joints, the sides edges may be up or down ②. So you can decide on the preferred board orientation before marking and routing the box bottom grooves ③. You will probably need to clamp in both directions when gluing-up.

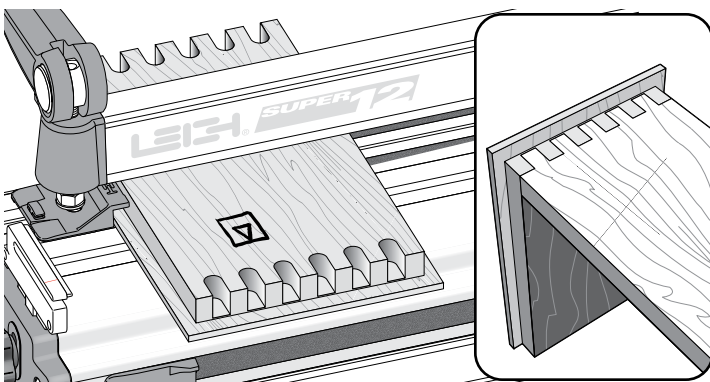

### 7-9 Rabbeted Half-Blind Box Joints

Rabbeted half-blind workpieces do not require blocking on D4R and SuperJigs if the rabbet is  $\frac{3}{8}$ " or less.

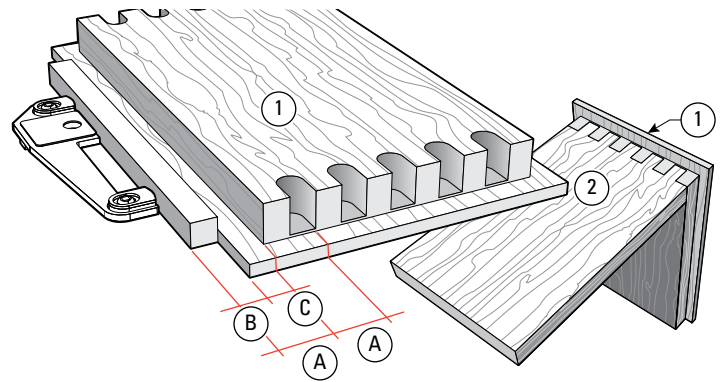

### 7-10 Rabbeted Joints on older D-Series Jigs

Rabbeted drawer fronts ① and the mating sides ② have to be blocked away from the side stops. Block drawer sides ② away from the side stops by one complete comb pitch (A). Block the drawer front ① away by (B) which is comb pitch (A) minus rabbet width (C). ■