

B975 User Guide

CHAPTER 6

Box Joints on Wider Boards

This chapter assumes you are familiar with all procedures in this user guide and you have established good joint fit and flushness using test boards before routing wide boards.

Watch the Online Instructional Videos at Leightools.com



- Click on the Support tab
- Go to the Instructional Videos and User Guides page

IMPORTANT SAFETY NOTE

Before using your Leigh B975, you must have completed the preparatory steps listed in the previous pages, including reading the jig safety recommendations in Chapter 2.

6-1 Getting Started The Box Joint & Beehive Jig can be used to rout box joints on boards wider than the jig width, up to 17-13/16" [453mm]. This is accomplished easily using a step-over cam and simple procedure. **This example uses 3/4" box joints on 3/4" thick boards.** Procedures for routing 1/2" and 3/4" joints are identical.

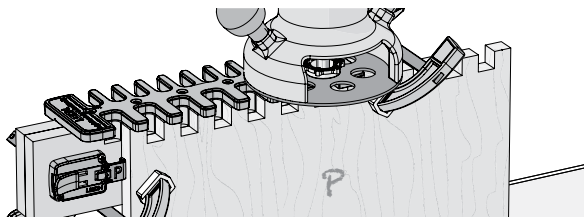

6-2 Parts Required 3/4" and 1/2" box joints are routed with the included Leigh No.160IND 1/2" straight bit and the Leigh e10 guide bushing (eBush). **No other bit diameter and guide bushing combination may be used.** Maximum board thickness for both joint sizes is 13/16" [20.6mm]. Depth of cut can be increased beyond the board thickness for raised joints. **Note:** Optional 1/2" diameter spiral upcut bits may also be used.

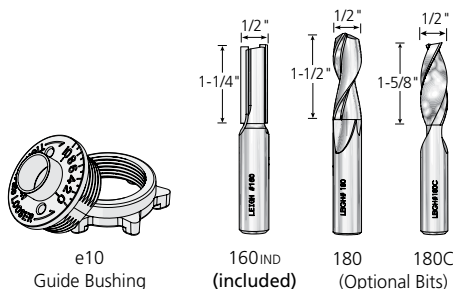

Bit Cutting Depth

Bit Diameter	1/2"
Item No. Carbide Tipped	160IND
Item No. Spiral HSS (Optional)	180
Item No. Spiral Solid Carbide (Optional)	180C

Depth of Cut	0"	1/4"	1/2"	3/4"	13/16"
0"					
1/4"					
1/2"					
3/4"					
13/16"					

6-3 Joint layout Review the drawing below. **Symmetrical** joints have pins (A) on both edges of the pin board, and sockets (B) on both edges of the socket board. **Note: Only symmetrical joints can be routed on wider boards.** Asymmetrical joints are not possible on wide boards.

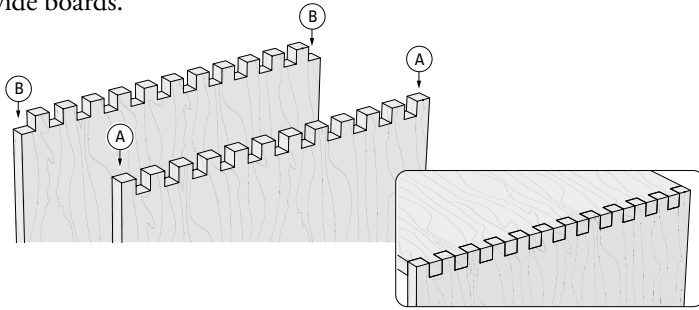

6-4 Board Width Selection Board widths are determined by the total number of pins and sockets in the joint design. Use this chart to choose your board width.

Board widths indicated in the chart below will produce full size pins and sockets at each board edge for symmetrical joints. Symmetrical joint board widths may be reduced as required, resulting in smaller but equally sized pins and sockets at each board edge.

Symmetrical Board Widths for 3/4" Box Joints on Wider Boards*											
Total Pins & Sockets	3	5	7	9	11	13	15	17	19	21	23
Inches	2 3/16"	3 11/16"	5 3/16"	6 11/16"	8 3/16"	9 11/16"	11 3/16"	12 11/16"	14 3/16"	15 11/16"	17 3/16"
Millimeters	56	94	132	170	208	246	284	322	360	398	437

Symmetrical Board Widths for 1/2" Box Joints on Wider Boards*																	
Total Pins & Sockets	3	5	7	9	11	13	15	17	19	21	23	25	27	29	31	33	35
Inches	1 7/16"	2 1/2"	3 1/2"	4 1/2"	5 9/16"	6 9/16"	7 5/8"	8 5/8"	9 5/8"	10 11/16"	11 11/16"	12 11/16"	13 3/4"	14 3/4"	15 3/4"	16 13/16"	17 13/16"
Millimeters	37	63	89	115	141	167	193	219	245	271	297	323	349	375	401	427	453

*Note: Wider boards are not possible when using a router table.

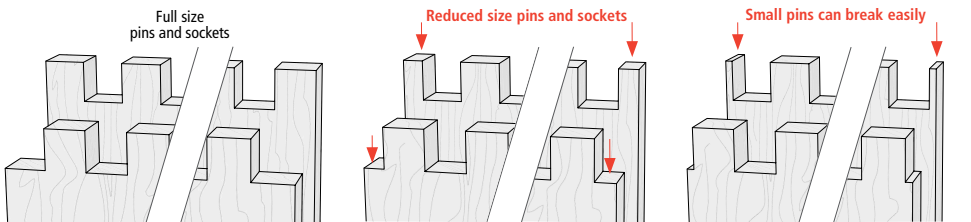

Width specified in the board width chart results in full size pins and sockets at each edge of the board.

When a symmetrical board width is reduced, the joint will have smaller, but equal sized pins and sockets at each edge of the board.

When the board width is reduced further, the result is very narrow and fragile pins at each edge of the board.

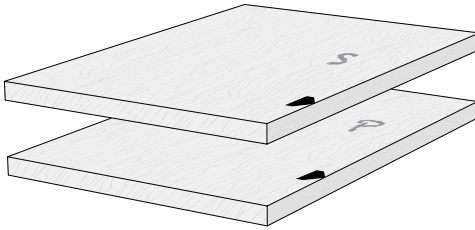

6-5 Wood Preparation In this example we are using boards with the following dimensions: 3/4" x 17-3/16" x 24" [19mm x 437mm x 203mm].

Mark the pin and socket boards and the board edge that goes against the side stop.

IMPORTANT: Read this whole chapter before routing any boards.

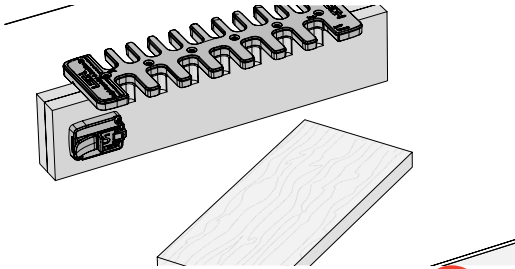

6-6 Boards wider than 9-11/16" [246mm] cannot be centered under the template. Therefore a narrower board must be used to position the side stop. Select a narrow board width from the chart and cut a board to that width, in this case, 3-11/16" [94mm].

Symmetrical Board Widths for 3/4" Box						
Pins & Sockets	3	5	7	9	11	1
inches	2 3/16"	3 11/16"	5 3/16"	6 11/16"	8 3/16"	9 11/16"
meters	56	94	132	170	208	246

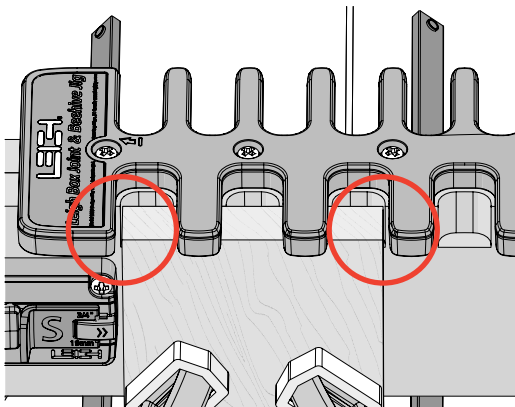

6-7 With the socket board stop fully retracted, clamp the narrow board in the vice and center the left end of the template over the board, leaving equal amounts of the board showing at each edge. Clamp the jig in place.

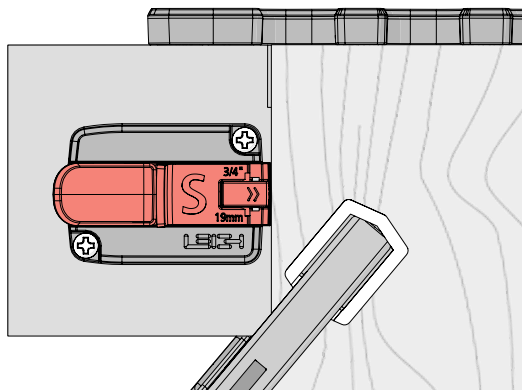

6-8 Slide the socket board stop until it touches the edge of the board and lock in place. The side stop is now set.

Remove the jig from the narrow board, and remove the board from the vice.

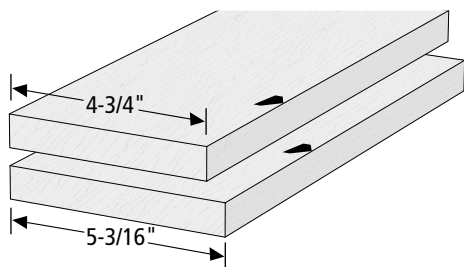

6-9 Boards Widths Less Than the Chart Width

For example: If the chart width is 17-3/16" [437mm] and your board width is 16-3/4" [425mm], the difference is 7/16" [11mm]. Select a narrow board width from the chart, in this case 5-3/16" [132mm], and reduce its width by the difference, 7/16" [11mm]. The narrower board width is now 4-3/4" [121mm]. Cut a board to that width and use the narrow board for step 6-7.

Symmetrical Board Widths for 3/4" Box

Pins & Sockets	3	5	7	9	11	1
inches	2 3/16"	3 11/16"	5 3/16"	6 11/16"	8 3/16"	9 11/16"
meters	56	94	132	170	208	246

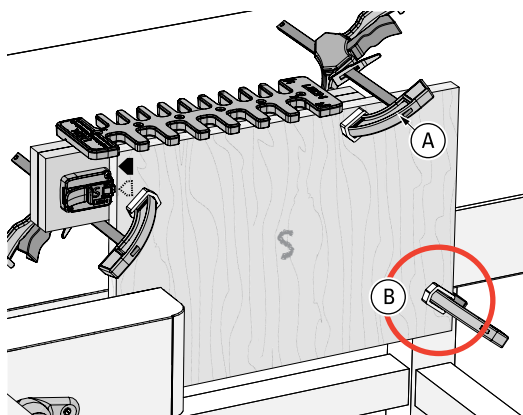

6-10 Routing the Socket Board

Clamp the wide socket board in the vice. Make sure the right hand clamp (A) will not interfere with the router. Wide and heavy boards should be secured with an extra clamp (B), or supported from the bottom.

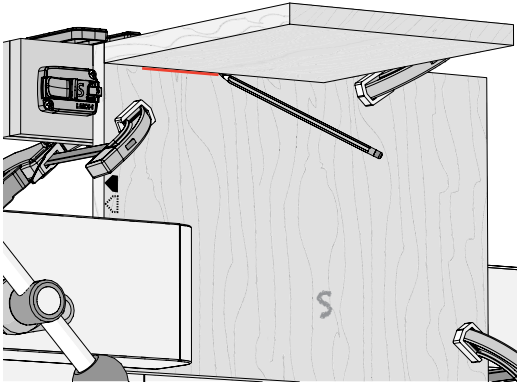

6-11 Set the depth of cut using a board the same thickness as the pin board, in this case $3/4"$. Holding the board flush under the template, draw a line on the socket board.

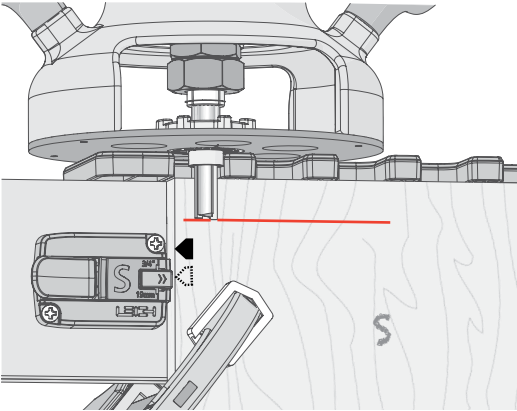

6-12 Place the router on the jig and adjust the tip of the bit up or down until it's at the center of the line. Rotate the bit and collet to ensure it spins freely and does not contact the eBush.

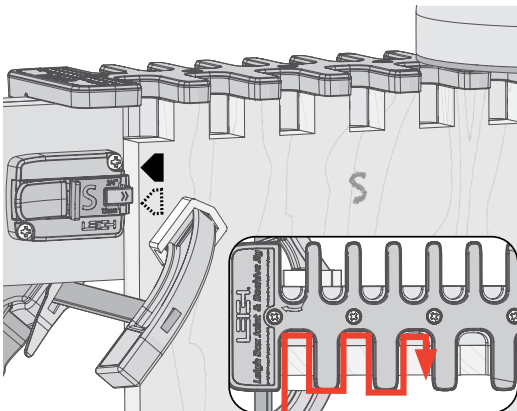

6-13 Now, hold the router firmly, as you rout straight in and out of all template openings.

Do not rotate the router.

Be sure the e10 touches the left side of the template opening on the way in, and the right side on the way out.

⚠ Do not remove the jig from the board.

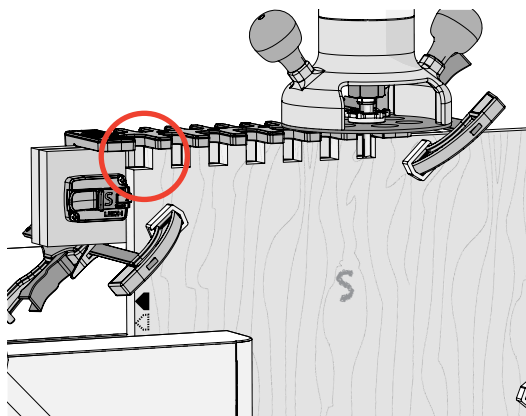

6-14 There will now be sockets on the left side of the board. The remaining part of the board is routed next, but first...

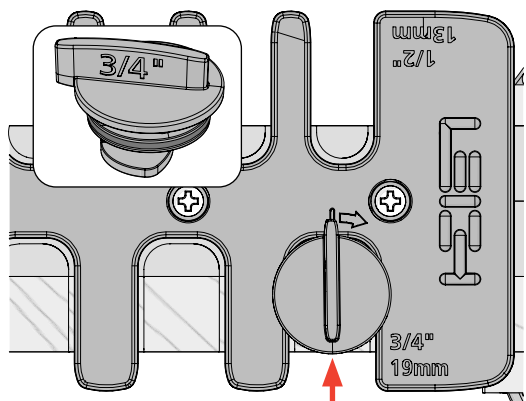

6-15 ...point the tip of the 3/4" cam to the back of the jig and insert it in the extreme right hand template opening.

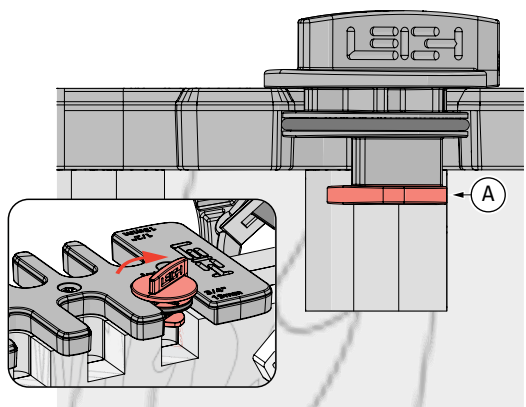

6-16 Turn the cam clockwise until the bottom part of the cam **A** touches the right side of the last routed opening of the board.

Leave the cam in place.

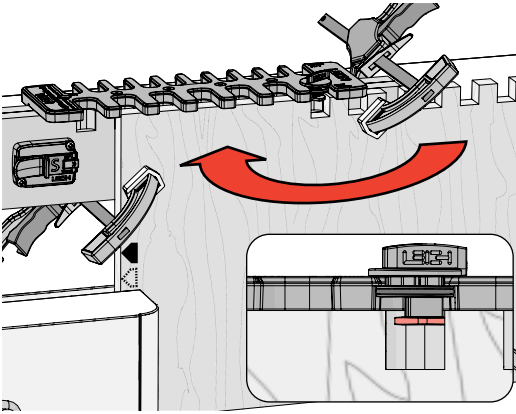

6-17 Unclamp the jig, flip the board horizontally, and re-clamp in the vice.

Position the jig on the board so the right edge of the cam just touches the inside right edge of the last routed opening. Clamp the jig in place making sure the right hand clamp will not interfere with the router. Remove the cam.

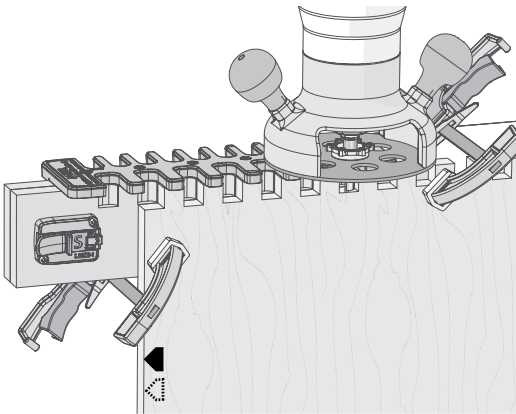

6-18 Rout the remaining part of the socket board. Remove the jig from the board and unclamp the board from the vice.

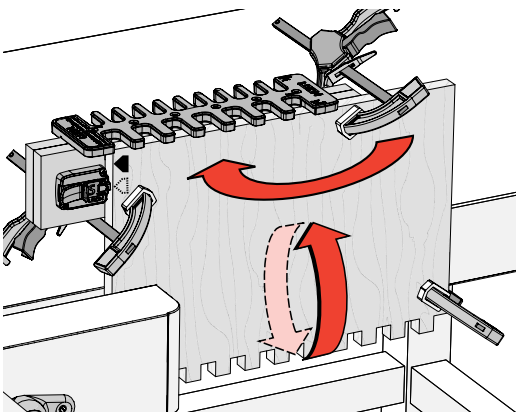

6-19 To rout the other end of the socket board, turn the board horizontally and flip it end for end, and re-clamp in the vice. Place the jig on the board with the side stop against the left board edge.

If you're making a box, rout a second socket board.

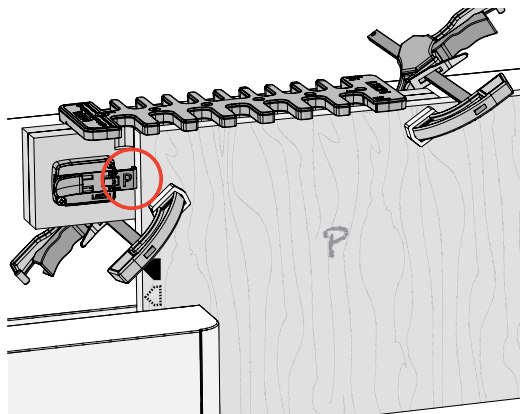

6-20 Routing the Pin Board

Flip the pin board stop to the **P** position. Place the jig on the board and slide it to the right until the left edge of the board touches the pin board stop. Clamp the board in place.

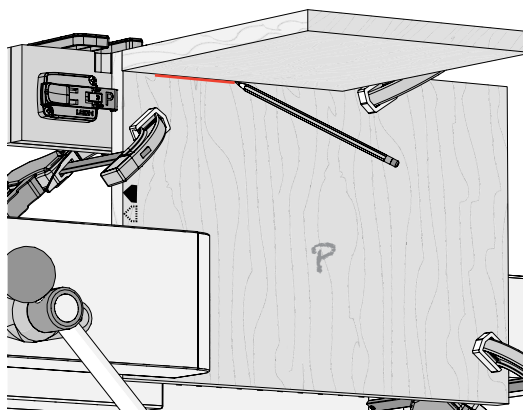

6-21 Socket and pin boards can be different thicknesses. Hold a board of the same thickness as the socket board, flush under the template, and draw a line on the socket board to indicate depth of cut.

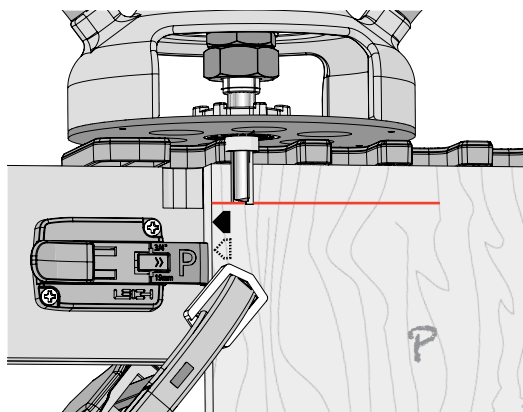

6-22 Place the router on the jig and adjust the tip of the bit up or down until it's at the center of the line. Rotate the bit and collet to ensure it spins freely and does not contact the eBush.

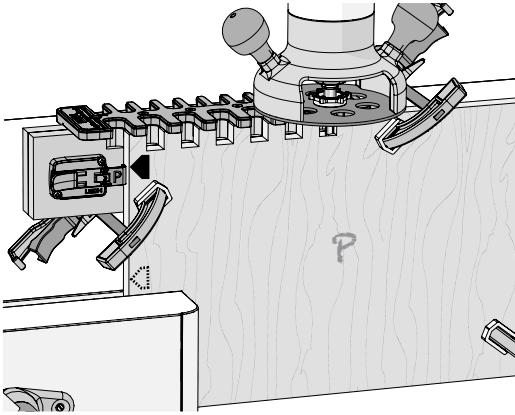

6-23 Now, hold the router firmly, as you rout straight in and out of each template opening. Be sure the e10 guide bushing touches the left side of the template opening on the way in, and the right side on the way out.

⚠ Do not remove the jig from the board.

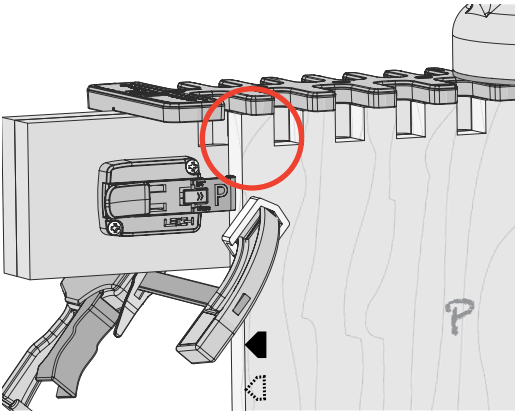

6-24 There will now be pins on the left side of the board. The remaining part of the board is routed next, but first...

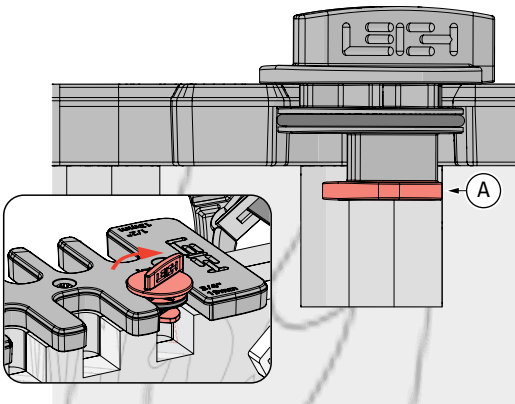

6-25 ...point the tip of the 3/4" cam to the back of the jig and insert it in the extreme right hand template opening.

Turn the cam clockwise until the bottom part of the cam **A** touches the right side of the last routed opening of the board.

Leave the cam in place.

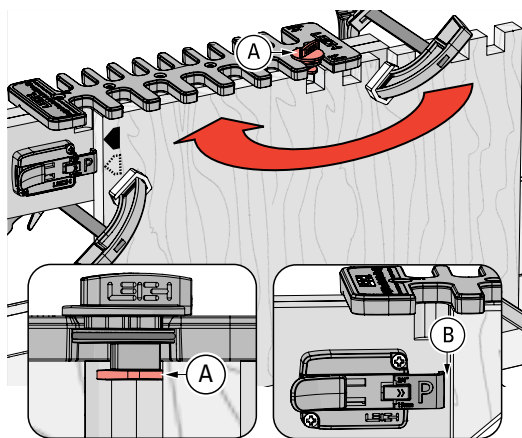

6-26 Unclamp and flip the board horizontally. Re-clamp in the vice.

The stepover cam (A), **not the side stop**, is used to position the jig on the board. There will be a small gap (B) between the side stop and the board. Place the jig on the board with the edge of the cam just touching the inside right edge (A) of the last routed opening of the pin board. Clamp the jig in place. Rout the rest of the pin board.

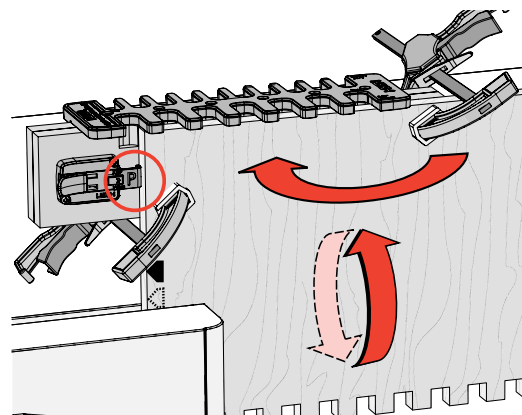

6-27 Remove the jig and unclamp the board from the vice.

To rout the other end of the pin board, turn the board horizontally and flip it end for end, and re-clamp. Place the jig on the board with the side stop against the left board edge.

If you're making a box, rout a second pin board.

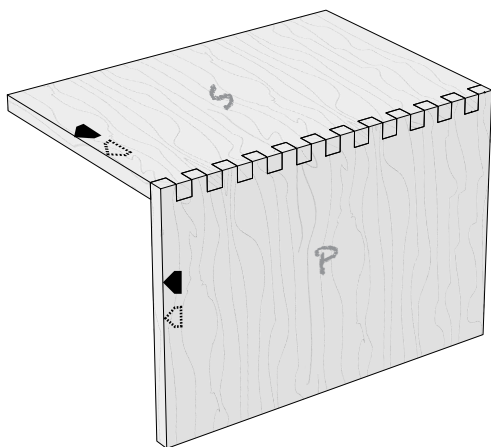

6-28 Assemble the joint, keeping the marked board edges aligned. ■