

## B975 User Guide

# CHAPTER 4 Mounting & Assembly

*The instructions on the following pages will guide you through the assembly process for the Leigh B975.*

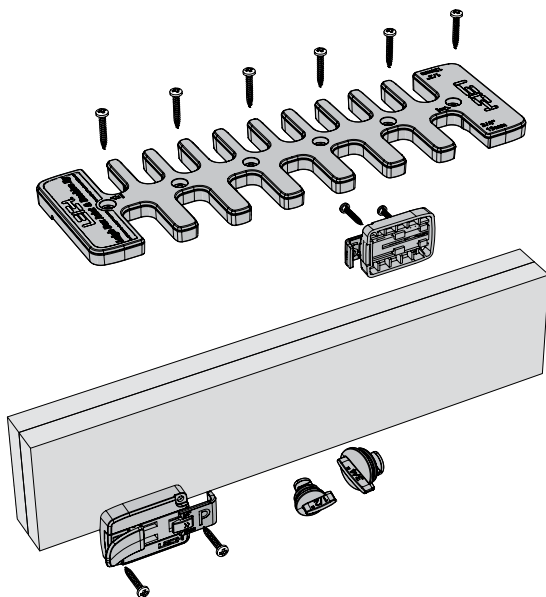

Watch the Online  
Instructional Videos  
at [Leightools.com](http://Leightools.com)



- Click on the Support tab
- Go to the Instructional Videos and User Guides page

### You will need:

- A workbench with vice or a portable workbench
- 2 pieces of 3/4" MDF to make a beam 1-1/2" x 3-1/2" x 16" [38mm x 90mm x 406mm]
- Router with 1/2" collet
- Electric drill, preferably bench or pedestal, but handheld will work
- 1/8" drill bit
- Two Quick-Grip clamps
- Square, ruler or tape measure
- No.2 Phillips screwdriver
- Wood Glue

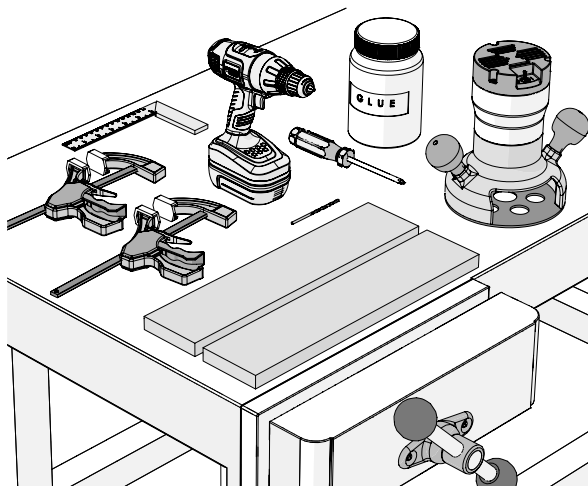

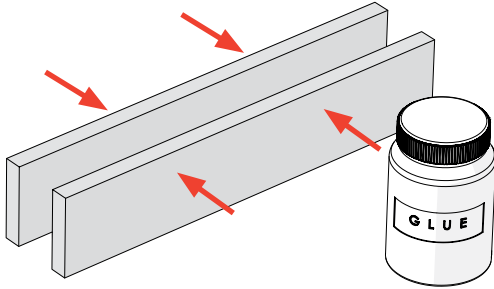

**4-1 Making the Beam** We recommend laminating the two pieces of 3/4" MDF. Place the glued pieces in a vice or use clamps to hold them together. The template will be attached to the top of the beam, so be sure the top edges are flush and free of glue residue. Set aside to dry completely. Alternatively, a common 2x4 may be used. See step 4-15 for special instructions.

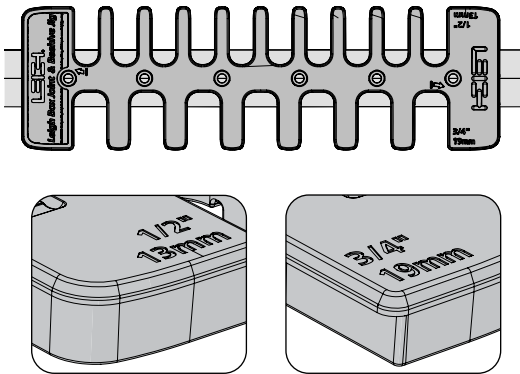

**4-2** One side of the template is used for 3/4" box joints and the other side is used for 1/2" joints.

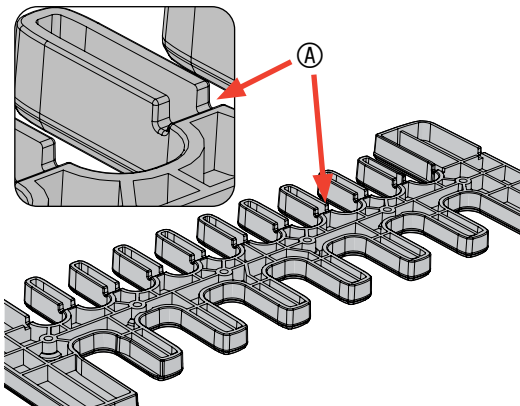

**4-3** The 1/2" comb has positioning ridges **A** molded into the bottom side of the template.

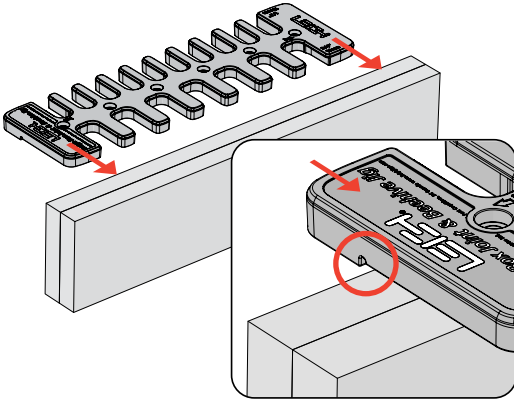

**4-4** With the 3/4" comb facing you, lay the template flat on the beam and center it left to right. Slide the template forward until the ridges on the underside of the 1/2" comb contact the back of the beam. The template is now positioned correctly.

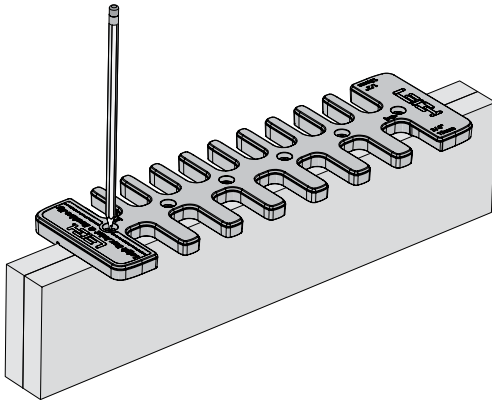

**4-5** Use a pencil and mark the location of all screw holes on the top of the template. Hold the template in place and proceed to the next step.

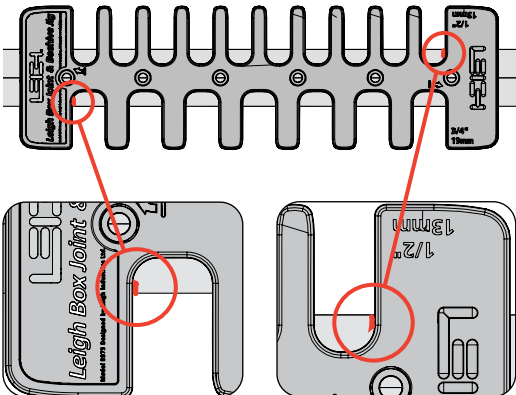

**4-6** Make a pencil line on the top of the beam at each end of the jig on the 3/4" and 1/2" sides.

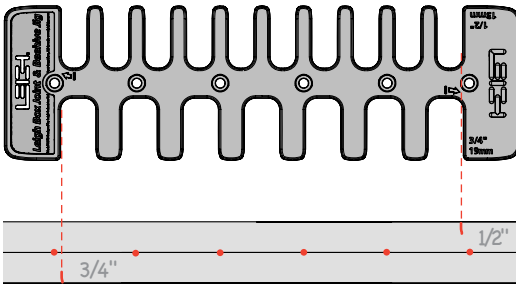

**4-7** Remove the template and mark  $3/4"$  and  $1/2"$  beside the lines, to indicate which is the  $3/4"$  and which is the  $1/2"$  side of the beam.

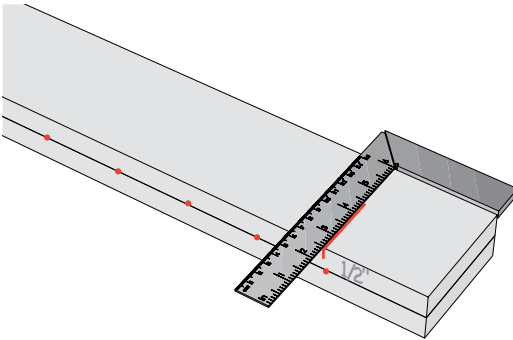

**4-8** Mark layout lines for the side stops. First, place the beam flat on the workbench with the  $1/2"$  side of the beam facing up. Use a square and draw a vertical line down from the positioning mark on the top of the beam.

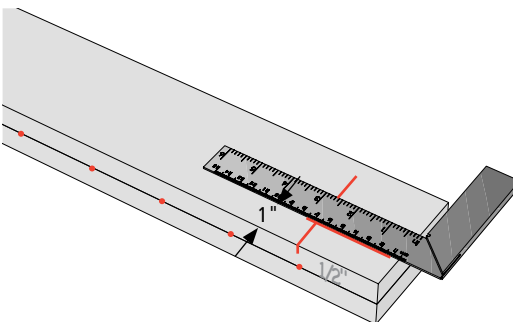

**4-9** Next, draw a horizontal line,  $1"$  down from the top of the beam.

Rotate the beam and repeat for the  $3/4"$  side.

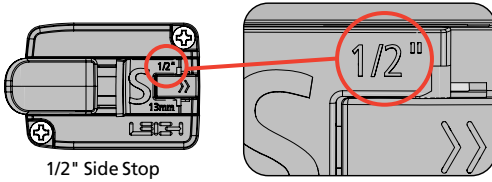
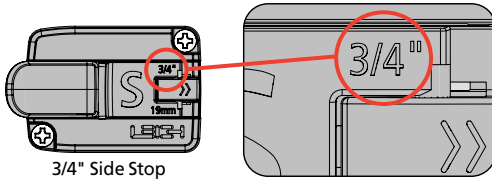

**4-10** The 3/4" and 1/2" side stops will be attached in the following steps.

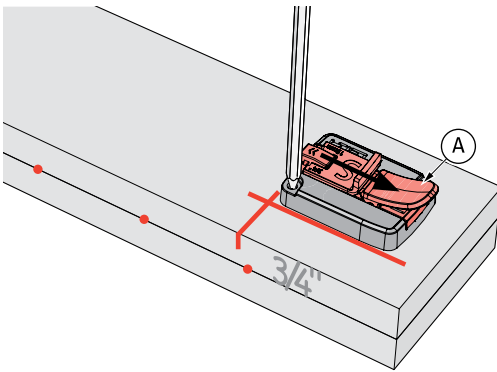

**4-11** Install the 3/4" side stop. Lift the thumb lock (A), retract the center portion of the 3/4" side stop fully and press the thumb lock down to lock it in place. Position it against the layout lines as shown.

Use a pencil to mark the screw hole locations.

Rotate the beam and repeat the process for the 1/2" side.

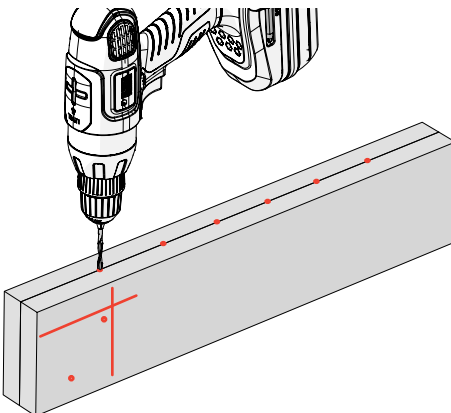

**4-12** Use a drill press or hand drill with a 1/8" bit to drill pilot holes at all screw hole locations.

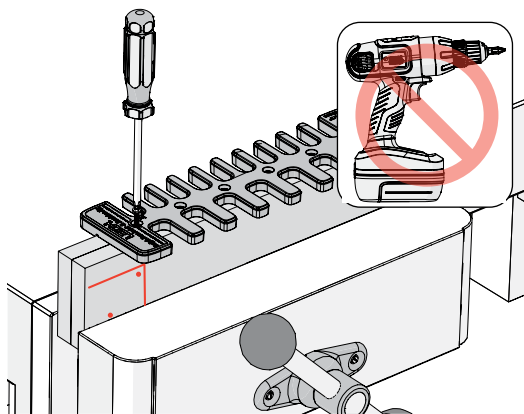

**4-13** Clamp the beam in the vice with its 3/4" side facing you. Position the template on the beam with the 3/4" side of the template facing you. Align it with the pre-drilled holes.

Use a screwdriver to attach the template with six of the included screws. **⚠ Do not use a power drill, as this may overstress the template.**

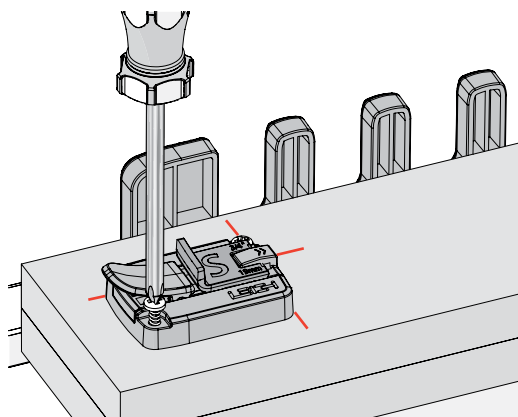

**4-14** Place the beam on the workbench with the 3/4" side of the beam facing up. Position the 3/4" side stop against the horizontal and vertical lines, with the thumb lock facing the left end of the beam, and attach it using the included screws. Again, use a screwdriver, not a power drill, to attach the side stop.

Repeat the process with the 1/2" side stop on the 1/2" side of the beam.

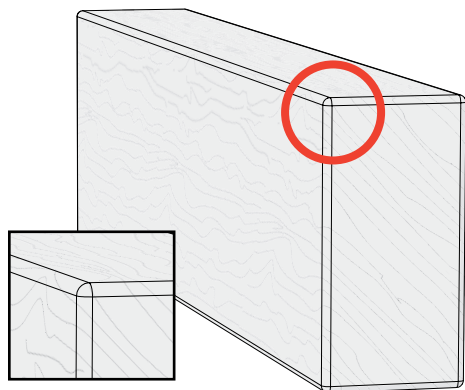

**4-15** Alternatively, you can use a straight, flat 16" [406mm] piece of common 2x4. Since a 2x4 has slightly rounded corners, the top edge should be squared off.

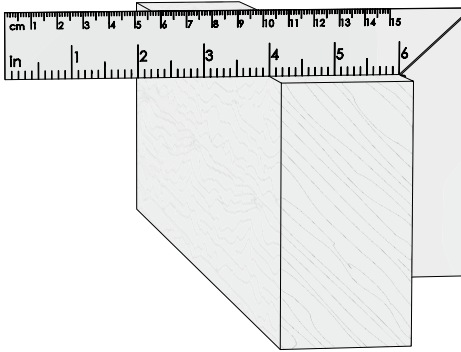

**4-16** Use a table saw, router table or jointer to skim off the top surface of the 2x4. Now go back to step 4-7 for the rest of the beam preparation.

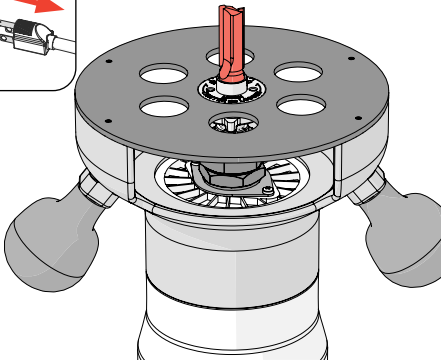
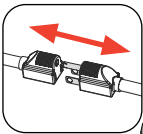

#### **4-17 Install the Bit**

Install the No.160IND 1/2" straight bit (or equivalent) in the router. The bit goes through the guide bushing and fits in the router collet.

Tighten the collet and rotate the bit and collet to ensure it spins freely and does not contact the eBush or eBush nut.

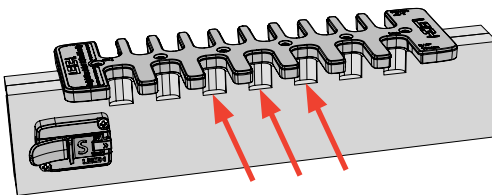

#### **4-18 Prepare the Beam**

To prevent tearout of the beam, grooves must be routed in all template openings, on both sides of the beam, as shown in the following steps.

Preparing the beam is particularly important when using a common 2x4 because its side grain will tear out badly.

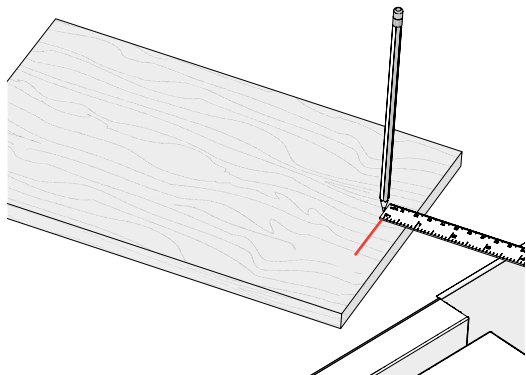

#### 4-19 Depth of Cut

Select a board at least 9-3/4" [248mm] wide and 1/2" to 3/4" thick. Length is not important as long as it can be clamped safely in the vice.

Set the depth of cut by marking a line 3/4" from the top end of the board. Clamp the board in the vice with the depth of cut line facing you.

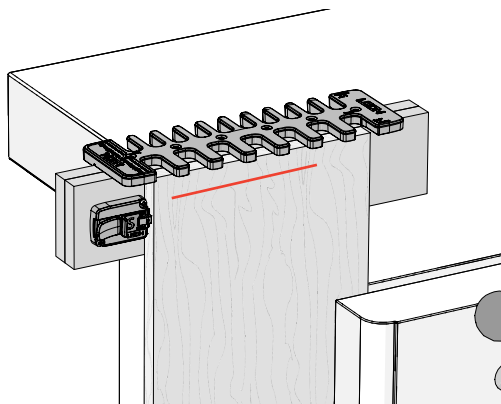

**4-20** With the socket board stop fully retracted, and the 3/4" side of the jig facing you, lower the jig onto the board. Slide the jig over until the left edge of the board touches the socket board stop as shown.

Clamp the jig in place.

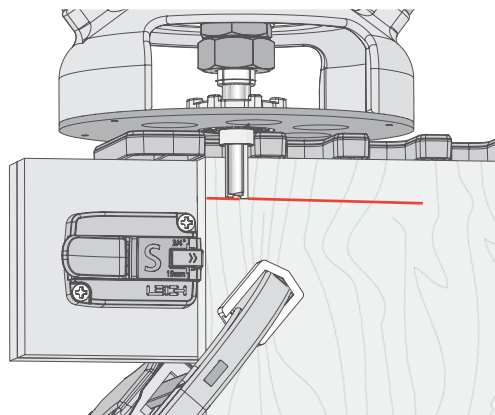

**4-21** Place the router on the jig and adjust the tip of the bit up or down until it's at the center of the line. Rotate the bit and collet to ensure it spins freely and does not contact the eBush.



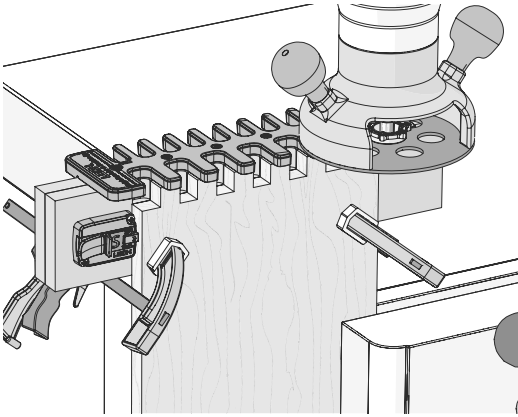

**4-22** Hold the router firmly and rout through the board and into the beam, in each template opening. Be sure the guide bushing touches the left side of each template opening on the way in and the right side on the way out.

Use the other end of the board and repeat for the 1/2" side of the jig.

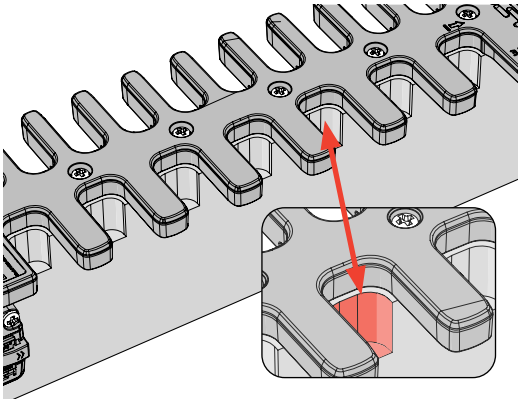

**4-23** There will now be a clean groove in each template opening on both sides of the beam.

The beam and jig are now ready to use. ■

This page is left blank intentionally.