

Mounting the FMT Pro

Jig Assembly and Mounting

The Leigh FMT Pro comes almost fully assembled with all adjustments factory set — however, before you start to set up your Leigh FMT Pro Jig, make sure you have received all the required parts.

- 1. 1 The main Jig Body, complete with:
1 Table ①
- 2. 1 Router Sub-Base ②
- 3. 1 User Guide
- 4. 1 Box Containing:
 - A 2 Vacuum Hose Adaptors
 - B 4 Jig Hold-Down Nuts and Bolts 1/4"-20
 - B 4 U-Posts with 4 Set-Screws and Four 3/4" Countersink Screws
 - B 4 1" Countersink Screws
 - B 3 Hex Socket Button Head Screws 10x24 x 3/8"
 - B 2 Hex Socket Button Head Screws M6
 - C 4 High Shim Spacers
 - C 4 Low Shim Spacers
 - C 1 1/4" and 1/2" Centering Mandrel
 - C 1 8 and 12mm Centering Mandrel
 - D 1 5/16" HSS Spiral Upcut 1/2" Shank
 - E 2 Outrigger Bars with 4 Screws and Nuts
 - F 1 Leigh Square Drive Screwdriver
 - F 1 Leigh 1/8" Hex Ball Screwdriver
 - F 1 5/64" Hex Key
 - F 2 Router Hold-down Rods
 - G 5 5/16" guides (or 6x8mm with FMT Pro-M) & 1 Guide Stand
 - H** 1 Side Stop Fence with Lever**
 - I 2 Cam-Action Speed Clamp Assemblies

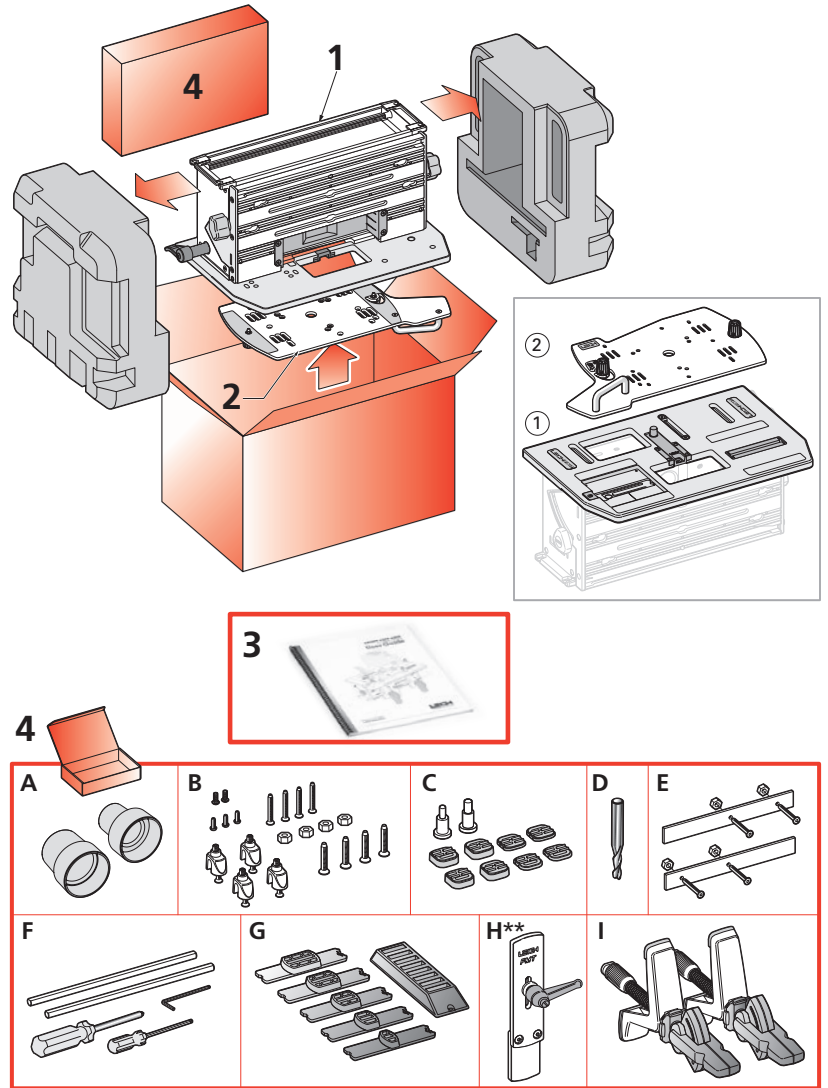

VACUUM BOX UPDATE: Most drawings throughout this user guide show an older version of the vacuum box, clamp plate and top extrusion. All FMT Pro jigs are shipped with the newest parts. These changes are reflected in Appendix III.



**** SIDE STOP UPDATE:** Some illustrations show the side stop fence with a “knob”. All FMT Pro jigs are shipped with a side stop fence with a “lever”, (see H in drawing above).

Note: Any optional accessories that you ordered may also be inside the parts box, or packaged inside the main carton. If any of these items are missing from your order, please notify your supplier or Leigh Industries immediately.



Watch the Online Instructional Video

Scan the QR Code for instant video

To view the instructional video online go to Leightools.com support section. Stream while you work to your smart phone or tablet.



Scan QR Code

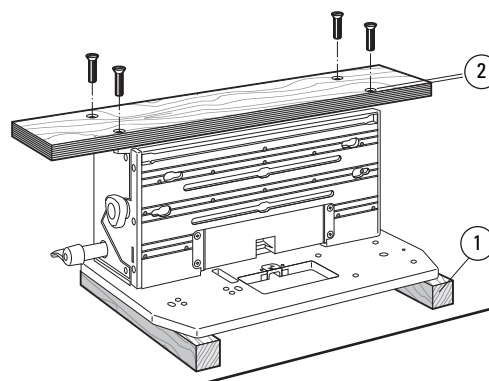
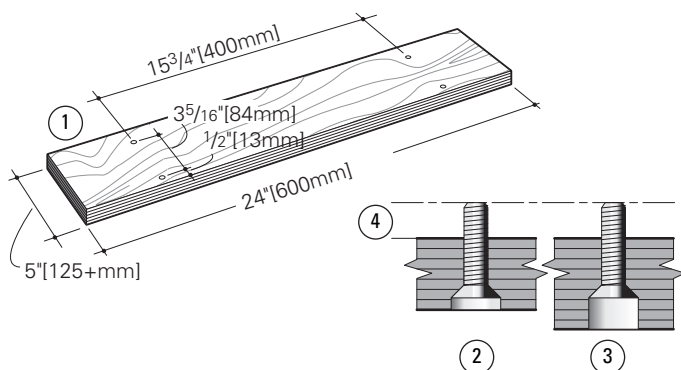

1-1 Mounting the FMT Pro Prepare a flat board at least $\frac{3}{4}$ " [20mm] thick, a **minimum** of 24" x 5" [600x125mm]. Drill four $\frac{7}{32}$ " [7mm] holes on $15\frac{3}{4}$ " x $3\frac{5}{16}$ " [400x84mm] centers, $\frac{1}{2}$ " [13mm] **in from the front edge of the board** ①. Countersink ②, or counter-bore ③ if board is thicker, the underside so that the four $\frac{1}{4}$ -20 x 1" long machine screws will project above the top surface by $\frac{3}{8}$ " [9,5mm] ④.

1-2 Turn the jig upside down on two wooden blocks ① (to protect the table and sight knob). Using the four nuts and four flathead countersunk machine screws, bolt the base board to the jig using the two nut recesses in each end housings. **The $\frac{1}{2}$ " [13mm] front edge ② to the front of the jig (of course).** Now you can clamp your FMT Pro to any bench.

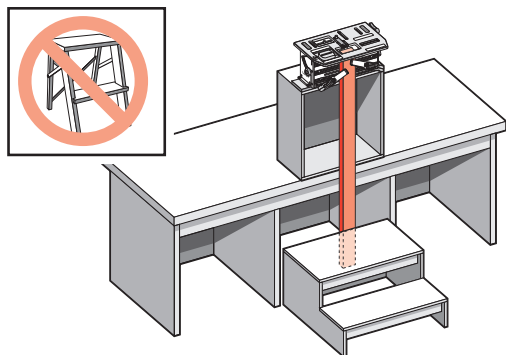

1-3 For routing long vertical rails it may be necessary to build a jig stand to mount securely on your bench. Make the stand and bench height combination sufficient to accept the board length you have in mind. *The jig stand should be bolted securely to the bench.* Make up a stable platform as shown here to stand on. **Do not use a collapsible step stool, these are unstable and unsafe.** ■