

D4R Pro - CHAPTER 7

Router Preparation

Prepare your router for optimal use with the D4R Pro.

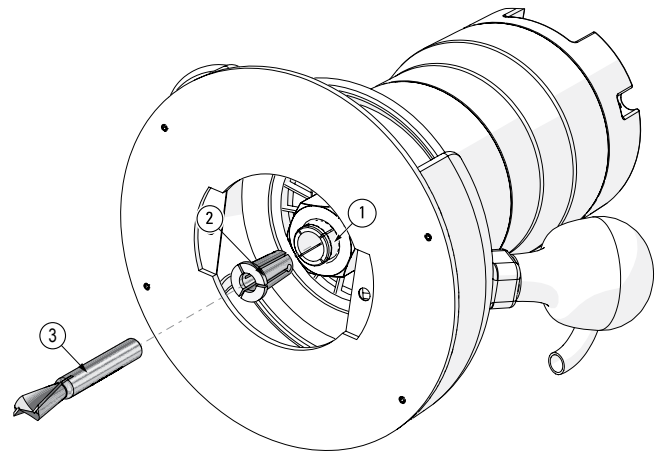
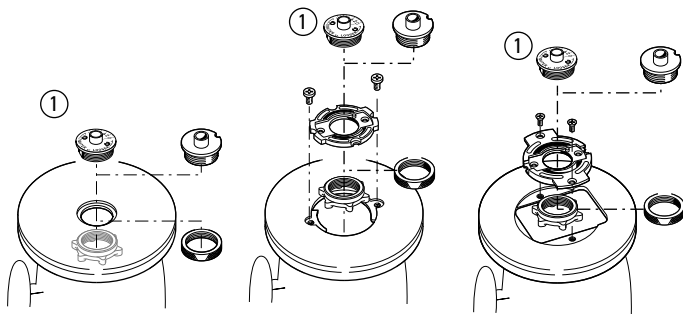

7-1 Fit the included e7-Bush ①. Some routers may require adaptation for the e7 to fit, *see page 69*. If the eBush is incompatible with your router, any $7/16$ " [11,1mm] guidebush (min. depth $1/4$ ", *see page 70*) will work for all Through and Half-Blind joints. The e7 is required for box joints on the D4R Pro.

7-2 The D4R Pro and accessory templates utilize both 8mm and $1/2$ " shank bits. Your router requires a $1/2$ " collet for optimum versatility ①. Included 8mm shank bits fit an 8mm collet directly. Routers with $1/2$ " collets must use $1/2$ " to 8mm collet reducer ② supplied with the jig. Collet reducer ② is inserted in router collet ① (chuck) and 8mm shank bit ③ is inserted in collet reducer.

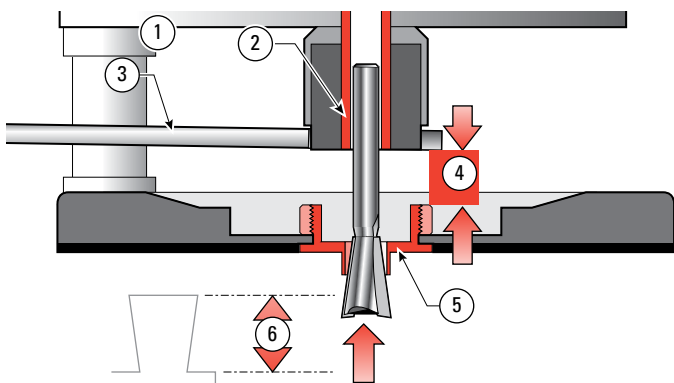

7-3 When fitting a bit to the router ①, fit the shank as far into the collet ② as possible. Always rout with the collet as close to the guidebush as possible. Usually you can't securely grip the collet nut with a wrench ③ if the collet is at its optimum low position. Fit the bit so that the remaining travel ④ between collet and guidebush ⑤ will let the bit reach the required depth of cut ⑥.

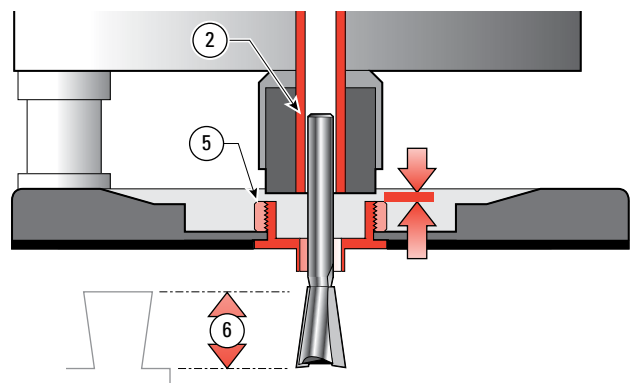

7-4 Tighten the collet ② securely and lower the collet to adjust the depth of cut ⑥, but make sure the collet does not contact the guidebush ⑤. Some smaller collets can go down into the inside of the guide bush. Take advantage of this.

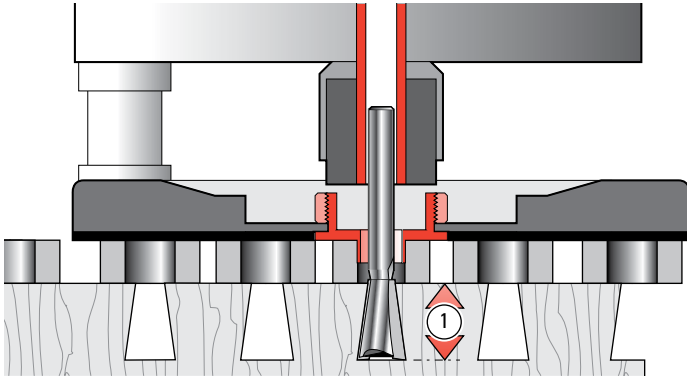

7-5 Depth of Cut: The depth of cut always refers to the actual depth of the cut into the wood beneath the guidefingers ①.

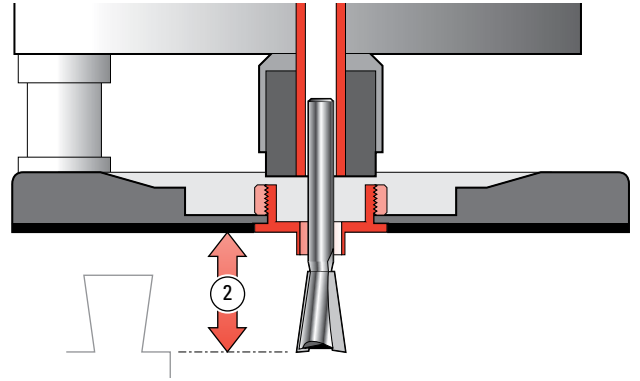

7-6 Depth of cut is **not** the distance the bit projects from the router base. This is **bit projection** ②. This guide generally refers to depth of cut. Bit projection ② is always .450" [11,5mm] more than depth of cut.

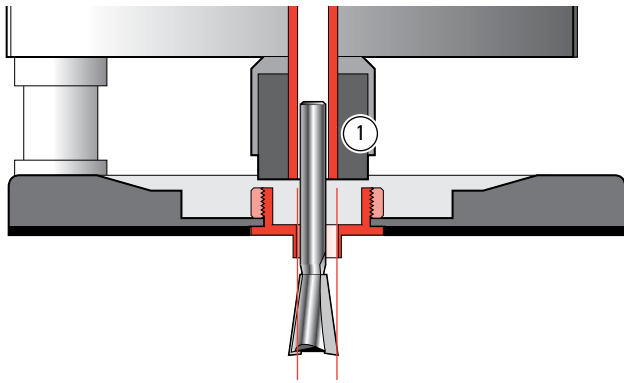

7-7 Ideally, the router collet (and bit) should be concentric (centered) to the guidebush as in figure 7-6. Regrettably, this is often not the case; the bit can be off center (eccentric to) the guidebush ①. The illustration shows the problem highly exaggerated. The good news: bit to bush alignment doesn't affect joint fit or flushness; both are "adjusted out" in normal jig setup.

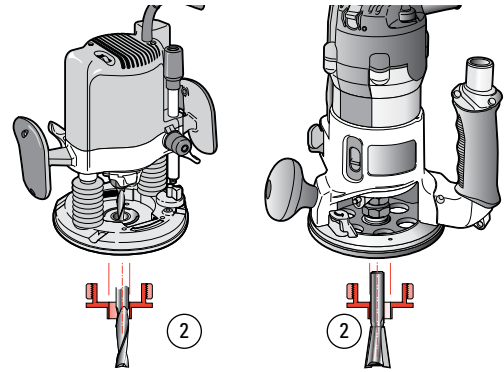

7-8 Concentricity problems can only arise if two routers are used for through dovetails, (one for pins; one for tails). Routers with different bit to guidebush offsets ② (misalignment shown highly exaggerated)...

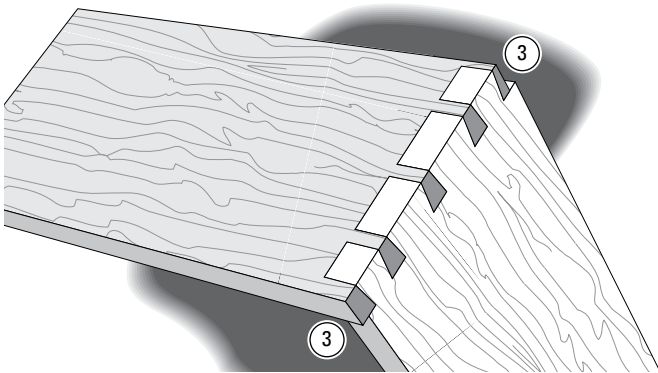

7-9 ...will cause pin to tailboard ③ misalignment (again, shown highly exaggerated).

Fortunately, some newer routers have sub-bases that can adjust for concentricity. If you don't have this type, it might pay to stick to a single router for through dovetails. ■

NOTE: Router Speed: Always use the fastest speed available on your router. The bits used on the D4R Pro are not large enough to warrant reducing router speed.