

Large and Small Through Dovetails

Watch the Online Instructional Video
The online video will reduce your learning time dramatically! Stream to your smart phone or tablet to use in your shop as a visual reference. Find the video in the Instructional Videos section of the Support menu at leighjigs.com.

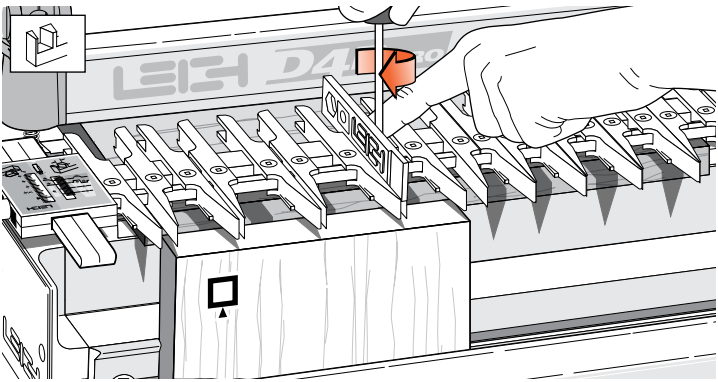

The following procedures considerably expand the D4R Pro jig's versatility. However, before attempting them, thoroughly master the techniques of Through Dovetails in Chapter 8.



9-1 LARGE THROUGH DOVETAILS

The procedures for using bits 90 and 160 or 100 and 150 are identical to the previous figures, except that a Leigh 716C or 5/8" [15,9mm] OD guidebush is used, and *each guidefinger must be at least 3/16" [5mm] apart*. Use the Leigh wrench gauge (3/16" [5mm] thick) to make sure there is enough separation. Note: Because the 716C or 5/8" [15,9mm] guidebush is used, the closest possible pin centers using these bit combinations is 1 3/8" [35mm], instead of 1" [25,4mm].

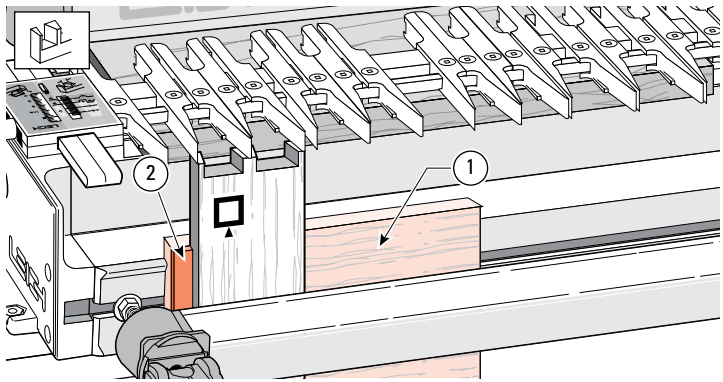

9-2 SMALL THROUGH DOVETAILS

Bits 50-8 and 60-8 allow you to create tiny through dovetails in material 3/8" [10mm] or less in thickness. This procedure is an extra bonus: the Leigh jig was not originally designed for it. The TD PINS scale does not go down far enough, so you have to space the boards away from the jig face with a shop-made block ① fitted with its own side stop ② (see 9-4). Use the e7 or a 7/16" [11,1mm] O.D. guidebush for these small joints.

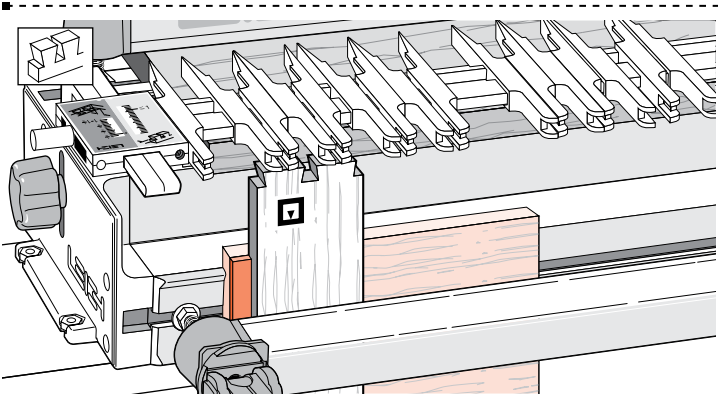

9-3 Use the same block with side stop when cutting the tails to ensure correct alignment of the pin and tail boards.

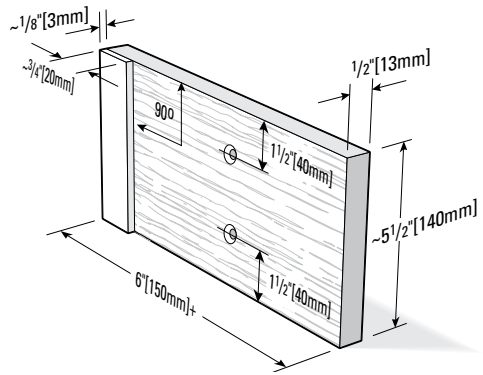

9-4 Make the block with its side stop out of 1/2" [13mm] stock as shown. Bore two 1/4" [6mm] holes, countersunk for a flat head screw (part no. 287) to allow the blocks to be used at either end of the jig.

