

Watch the Online Instructional Video

The online video will reduce your learning time **dramatically!** Stream to your smart phone or tablet to use in your shop as a visual reference. Find the video in the Instructional Videos section of the Support menu at leighjigs.com.



D4R Pro CHAPTER 4

Basic Jig Functions and Scale Modes

Here are the very basics for understanding the different D4R Pro dovetail modes and settings.

THE FOUR SCALE MODES

The Finger Assembly attaches to the support brackets in four different modes to match the type of joint you are cutting.

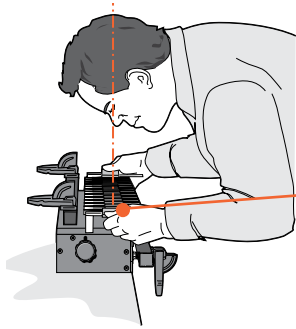

Always read scales from directly overhead to avoid parallax problems.

This index line is used when setting the finger assembly scales. The line is illustrated in red for clarity, but is black on the jig.

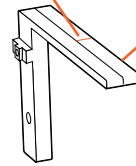

All D4R Pro jigs are shipped with "short" support brackets.

Note: Inch scales are shown here. Millimeter scales have identical layout.

The active scale is always on the right of each scale assembly.

The inactive scale is always on the left of each scale assembly and is upside down.

Each scale has its own mode icon (a drawing of the joint part made in that mode).

Scales are color coded. Silver background for Through Dovetails. Green background for Half-Blind Dovetails.

The specific settings for each scale are fully described in the appropriate chapters.

1. TD TAILS

3. HB TAILS

2. TD PINS

4. HB PINS

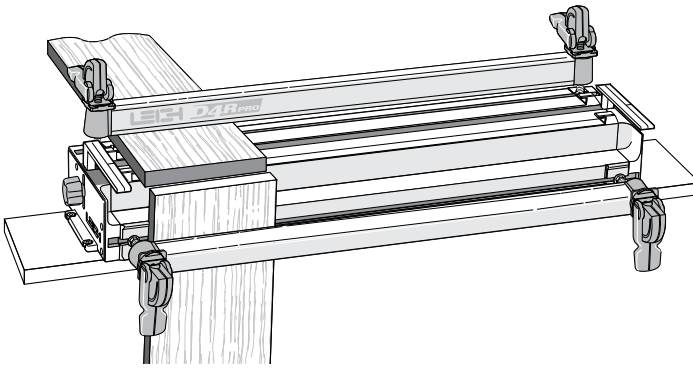

4-1 The two clamp bars hold workpieces horizontally or vertically. The side stops align the boards in the correct position each time.

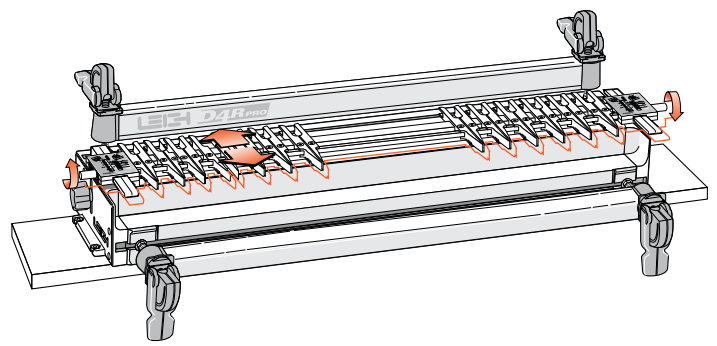

4-2 The guidefinger assembly slides on to the support brackets above the workpiece. The finger assembly is adjusted in or out using calibrated scales on each end to suit different thicknesses of vertical boards.

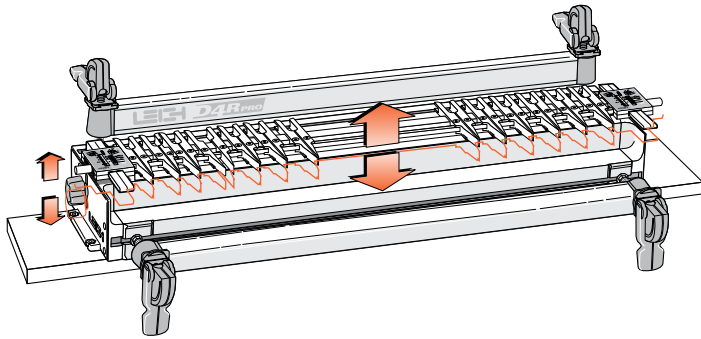

4-3 The finger assembly is raised or lowered using the support brackets to suit different thicknesses of horizontal boards. ■