

## Watch the Online Instructional Video

The online video will reduce your learning time **dramatically!** Stream to your smart phone or tablet to use in your shop as a visual reference. Find the video in the Instructional Videos section of the Support menu at [leighjigs.com](http://leighjigs.com).



## D4R Pro - CHAPTER 12

# Rabbeted Half-Blind Dovetails

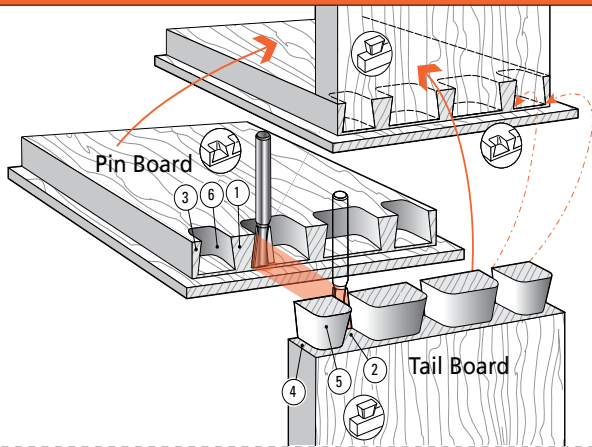

Before attempting rabbeted half-blind dovetails, first master the techniques of flush half-blind dovetails in chapter 10.

### 12-1 Rabbeted Half-blind Dovetail Terminology:

- |               |                    |
|---------------|--------------------|
| ① Pins        | ④ Half-pin sockets |
| ② Pin sockets | ⑤ Tails            |
| ③ Half-pins   | ⑥ Tail Sockets     |

The pins fit in the pin sockets. Joints should almost always end each side with half-pins.

### 12-2 Cutting Depth for Rabbeted Half-Blind Dovetails

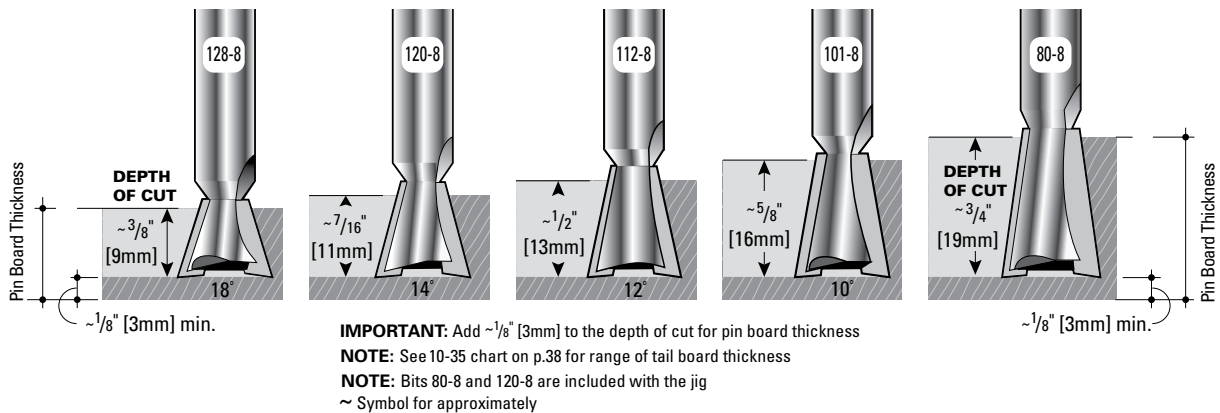

## ⚠ Important! Read This About Rabbeted HB Depth of Cut

Bit selection is critical. You need to select a specific dovetail bit for your rabbeted half-blind dovetail project, depending on the rabbet depth you are using.

- Choose one of the five  $1/2"$  [12,7mm] diameter dovetail bits shown above. See bit selection in Appendix II.
- Depth of cut must be as specified for each of the five bits illustrated above. *Exception: See fig.11-26. Note: No's 101-8, 112-8 and 128-8 are optional Leigh bits.*
- Raising the bit above its specified cutting depth will result in loose joints and may damage the jig, bit and/or guidebush. A lower setting will result in tighter joints that may not fit together.
- Small Depth of Cut adjustments will change joint fit tightness. See 10-3 to 10-5 for why.
- Rabbeted Half-blind PINS and TAILS are routed with the same dovetail bit and must be at the same Depth of Cut.
- All half-blind dovetail bits work with the Leigh e7-Bush supplied with your Leigh jig or a standard  $7/16"$  [11,1mm] outside diameter guidebush.
- Each dovetail bit will produce only one depth of cut. Only  $1/2"$  [12,7mm] cutting diameter bits can be used for half-blind dovetails.

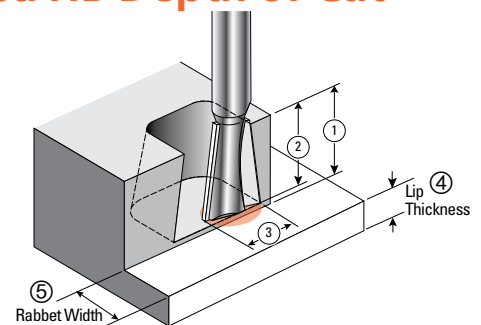

**RABBET DEPTH** ① determines the **maximum depth of cut** ② you can use. Select a bit with a depth of cut that is at least  $1/16"$  [1,6mm] **less** than the rabbet depth.

Lip thickness ④ will vary depending on overall board thickness – maximum  $3/8"$  when using undercut side stops.

Rabbet width ⑤ is variable and set to suit project.

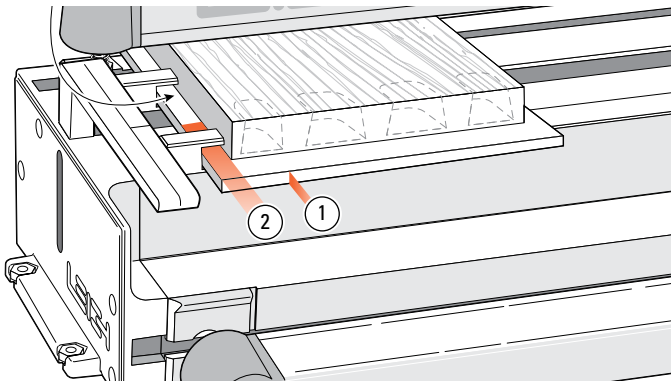

**12-3** Provided the drawer front lip is  $\frac{3}{8}$ " [9,5mm] or less in thickness ①, you can mount and rout rabbeted drawer fronts and sides exactly the same way as flush drawer fronts. If the lip is thicker or wider than  $\frac{3}{8}$ " [9,5mm] ② see 12-6 thru 12-8.

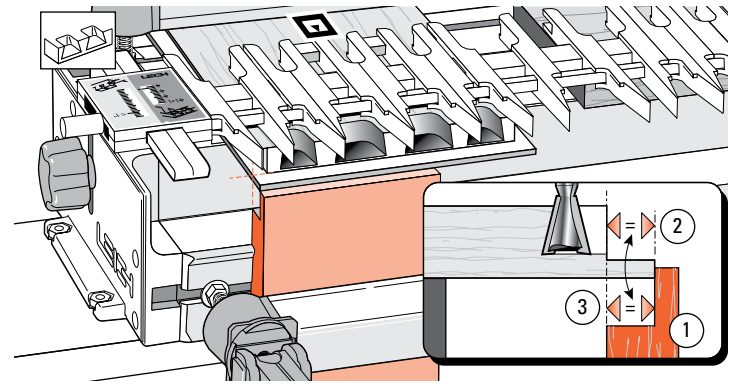

**12-4 Rabbeted Pins** You will need to clamp a scrap stop block ① in the front of the jig out from the jig's front face by exactly the depth of the rabbet ②. This brings the pin ends exactly in line with the front jig face ③, ensuring that the scale reading is accurate.

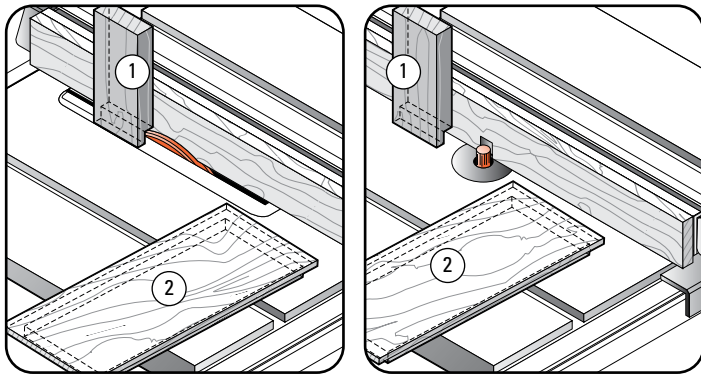

**12-5** An easy accurate way to do this is to rabbet the end of a scrap piece ① vertically over a dado blade or router bit at the same time as you rabbet the drawer front (horizontally) ②.

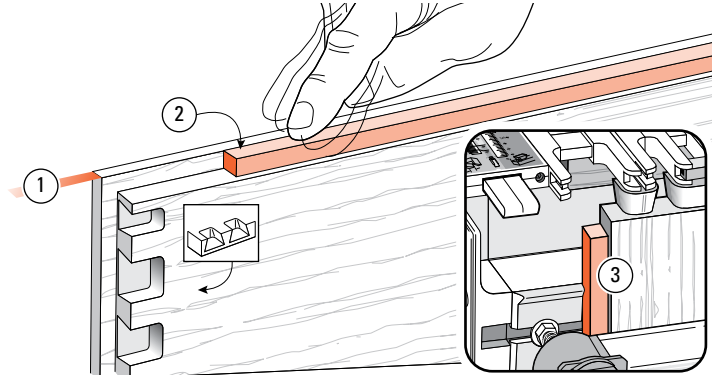

**12-6** If the lip thickness ① is greater than  $\frac{3}{8}$ " [9,5mm], it will not fit under the side stop. Block the drawer side away from the front side stop by exactly rabbet depth (see 12-3). Make up a block ② and stick it to the jig face ③ with double-sided tape. Make sure it touches the side stop. This will offset the drawer side from the side stop by the width of the rabbet, and align the sockets with the pins.

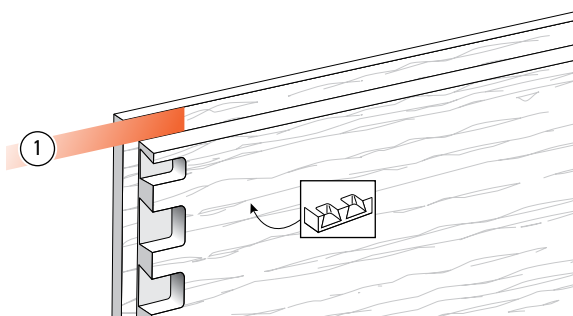

**12-7** If the rabbet width ① is greater than  $\frac{3}{8}$ " [9,5mm], the drawer side must be offset from the front side stop by the depth of the rabbet minus  $\frac{3}{8}$ " [9,5mm]. Make up a block to this measurement and stick it to the face of the jig, touching the front side stop. This will offset the drawer side away from the side stop and align the sockets with the pins.

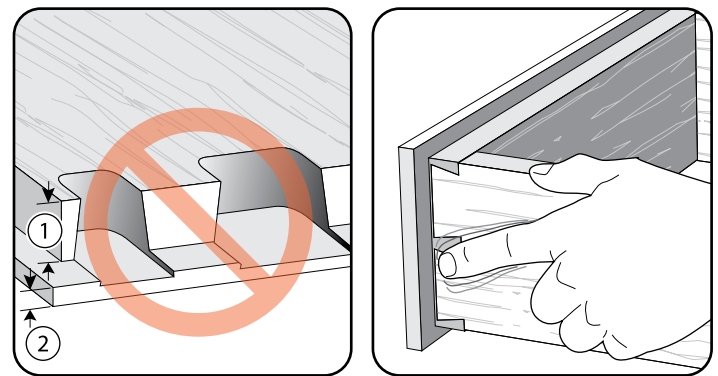

**12-8** Make sure you select a dovetail bit that has a working depth of cut less than the rabbet height ①. Otherwise, you will rout into the rabbet lip ②.

It is difficult to clean up the drawer sides and front corner after assembling a rabbeted drawer, so make sure the fit is flush before you complete the drawers (see 10-28 to 10-30). ■