

TD330 User Guide

CHAPTER 6 Router Table Operation

This chapter assumes you have set up your jig following the Mounting & Assembly instructions in Chapter 4, Steps 4-16 to 4-28. You should also be familiar with all procedures in this user guide.

IMPORTANT SAFETY NOTE

Before using your Leigh TD330, you must have completed the preparatory steps listed in the previous pages, including reading the jig safety recommendations in Chapter 2.



Watch the Online Instructional Video



Scan QR Code

Reduce your learning time dramatically! Stream to your smart phone or tablet to use in your workshop while you're working. See Instructional Videos section in Support menu at leightools.com or scan QR code for instant video.

6-1 Watching the online video in addition to reading this user guide will reduce your learning time dramatically. The video can be streamed to your smart phone or tablet and used in your shop as a visual reference. Visit leightools.com and find the video in the Support section.

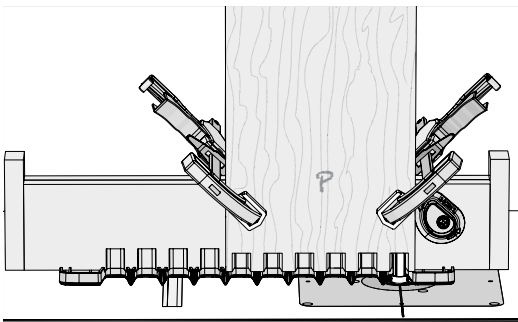

6-2 Getting Started The TD330 can be used to rout dovetail joints on a router table, on boards up to a maximum width of 12-7/8" [327mm] and up to 13/16" [20,6mm] thick. This example uses 3/4" [19mm] thick boards. Different board thicknesses may be joined.

6-3 Parts Required All through dovetails are routed with the included Leigh VM160CH 1/2" straight bit, Leigh VM80-500CH 1/2" 8° dovetail bit and Leigh e10 guide bushing (eBush). **No other bit diameters, angles and guide bushing combinations may be used.** Maximum board thickness for through dovetail tails is 13/16" [20,6mm]. **Note:** Optional 1/2" diameter spiral upcut bits may also be used.

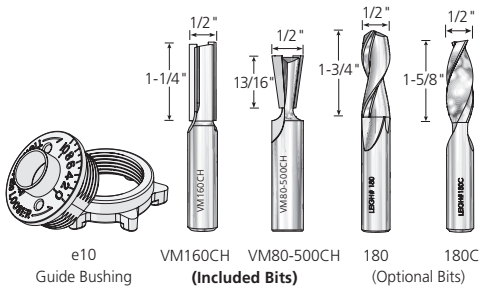

Bit Cutting Depth	
Bit Diameter	1/2"
Item No. Carbide Tipped	VM160CH
Item No. Carbide Tipped	VM80-500CH
Item No. Spiral HSS (Optional)	180
Item No. Spiral Solid Carbide (Optional)	180C

6-4 Router Table Requirements Router tables are typically used with a bearing bit or fence, however, the Leigh TD330 is guided around a guide bushing mounted in the router table. Leigh eBushes (guide bushings) are designed around the 1-3/8" diameter industry standard. See specifications below.

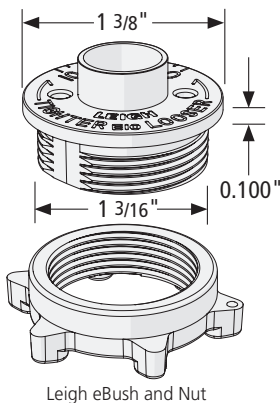

Leigh eBush and Nut

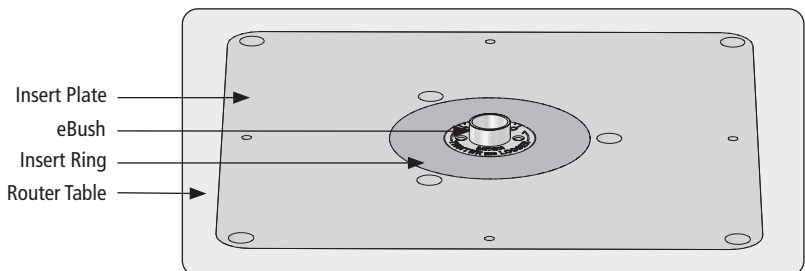
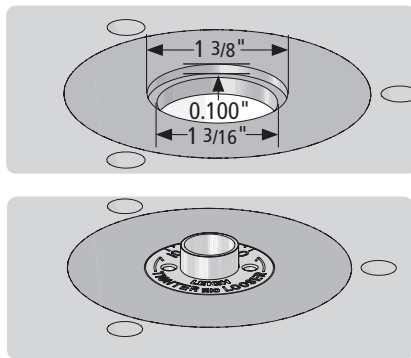

6-5 Insert Ring To install the eBush in your router table insert plate, you may need a 1-3/8" diameter counter bore insert ring (A). See previous step for specifications. Insert rings are not standard. You will need to check with your router table or insert plate (router lift) manufacturer, as to what adaptation, if any, is required.

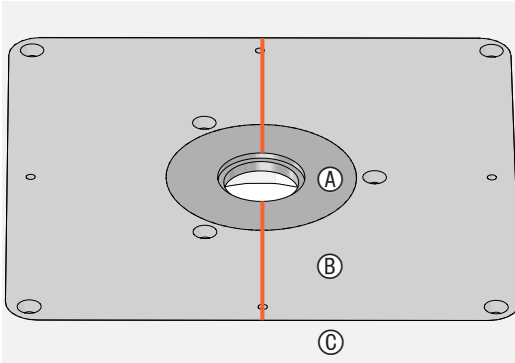
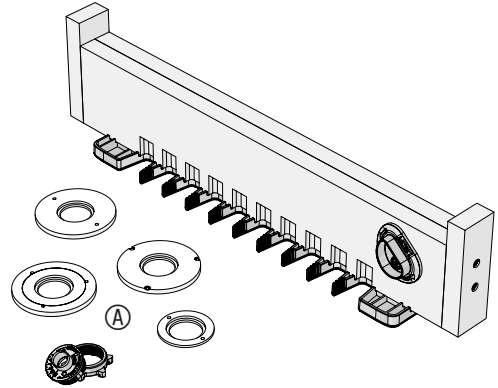

6-6 Draw a reference line with a permanent marker on the router table, from the 12 o'clock position to the 6 o'clock position, centered on the guide bushing opening. (shown in red for clarity only).

This will ensure correct orientation of the eBush to the insert ring (A), the insert plate (B), and the router table (C).

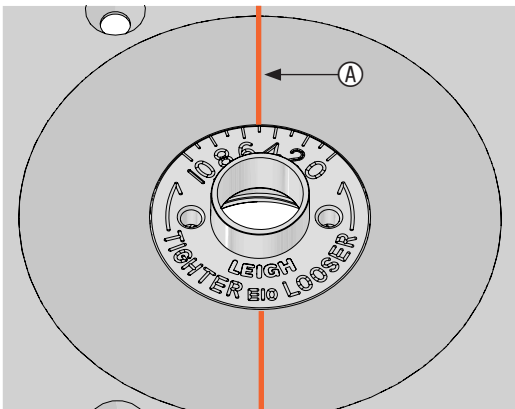

6-7 Install the e10 guide bushing in the router table. Set the eBush to the 5 position to start.

All settings for the eBush will be aligned to the line (A) you've drawn on the router table. The line will also help guide the TD330 when routing.

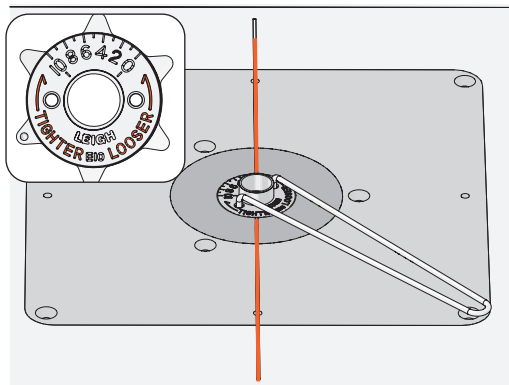

6-8 eBush adjustments are made with the included pin wrench. Markings on the eBush indicate which way to turn it for a looser or tighter fit. See Chapter 3.

Remember, every time you adjust the eBush you must re-tighten the eBush nut.

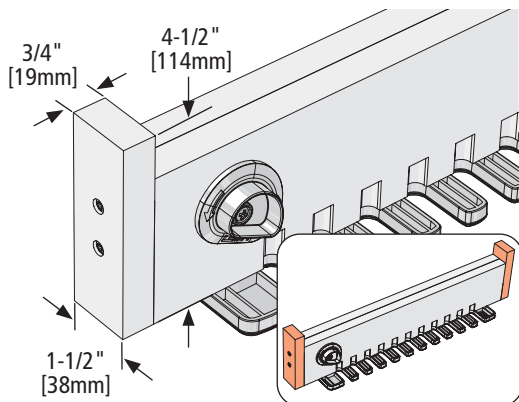

6-9 Safety Before using the jig on a router table, handles must be attached to the ends of the beam. Handles should be $3/4$ x $1-1/2$ x $4-1/2$ [19mm x 38mm x 114mm].

The handles will help keep your fingers away from the bit and help control the jig during routing.

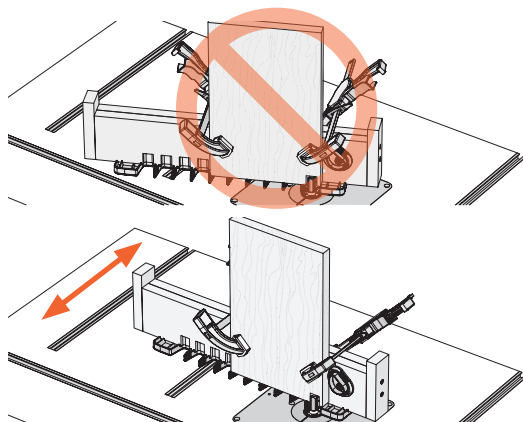

6-10 Remember the barrel of the eBush is elliptical, so changing the angle of the jig affects the diameter of the guide bushing, resulting in inconsistent pins and tails.

Always keep the jig parallel to the router table.

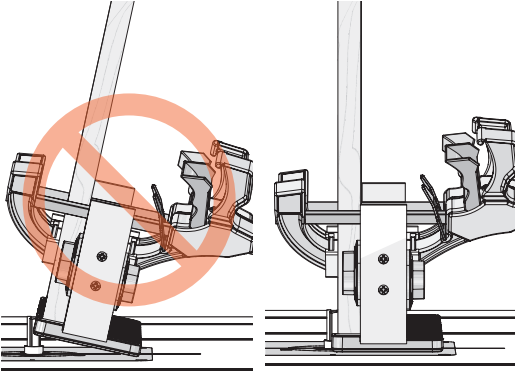

6-11 Never tilt the jig. Keep the jig flat on the router table at all times.

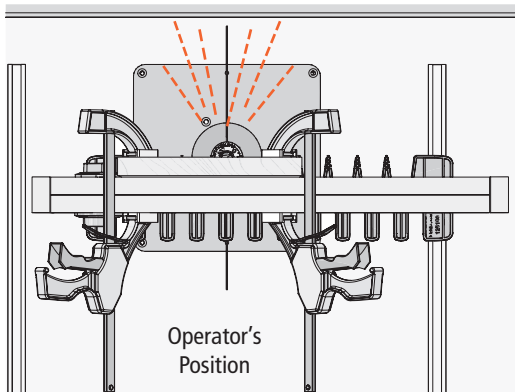

6-12 Chips and sawdust are thrown out at high speed. Always stand and use the jig away from chip and sawdust ejection.

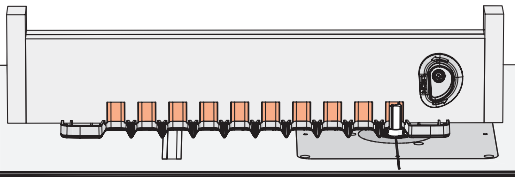

6-13 Reminder If you haven't already done so, you must rout grooves on each side of the beam (see Chapter 4, Steps 4-16 to 4-28).

6-14 Identify the **PINS** and **TAILS** sides of the jig on the beam.

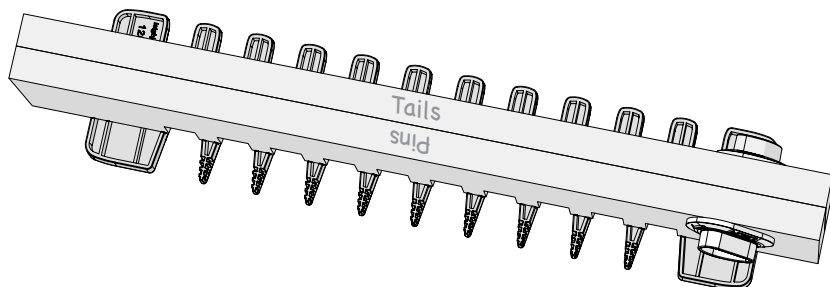

6-15 Through Dovetail Terminology

- Ⓐ Pin
- Ⓑ Pin socket
- Ⓒ Half-pin
- Ⓓ Half-pin socket
- Ⓔ Tail
- Ⓕ Tail socket

The pins fit in the pin sockets. Joints should almost always end each side with half-pins.

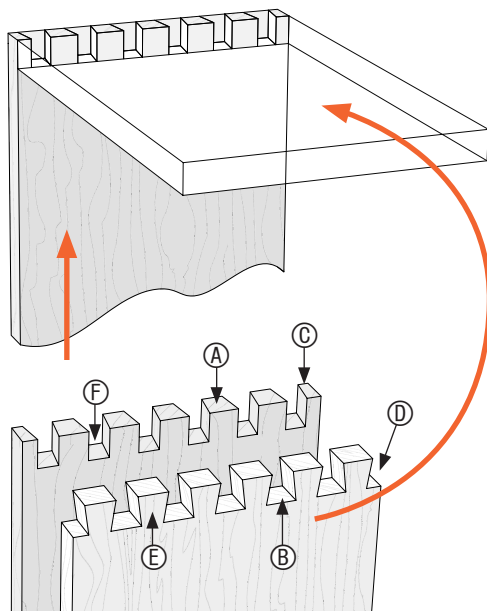

6-16 Board Width Selection Board widths are determined by total number of pins and sockets in joint design. Use this chart to determine board widths up to 12-7/8" [327mm].

Board Width Selection for TD330											
inches	No. of Tails	1	2	3	4	5	6	7	8	9	10
	Min	1 1/8	2 3/8	3 5/8	4 7/8	6 1/8	7 3/8	8 5/8	9 7/8	11 1/8	12 3/8
	Exact	1 1/4	2 1/2	3 3/4	5	6 1/4	7 1/2	8 3/4	10	11 1/4	12 1/2
	Max	1 5/8	2 7/8	4 1/8	5 3/8	6 5/8	7 7/8	9 1/8	10 3/8	11 5/8	12 7/8
mm	No. of Tails	1	2	3	4	5	6	7	8	9	10
	Min	29	60	92	124	156	187	219	251	283	314
	Exact	32	64	95	127	159	191	222	254	286	318
	Max	41	73	105	137	168	200	232	264	295	327

6-17 Board Width Selection Board widths indicated in the **exact** column of the chart will produce **half-pins** at each board edge. Board widths may be increased by 3/8" [9,5mm] resulting in larger, but equally sized pins at each board edge. Similarly board widths may be reduced by a maximum of 1/8" [3,2mm], resulting in smaller but equally sized pins at each board edge. Narrower widths may result in very small and weak pins at the edges of the pin board.

Symmetrical

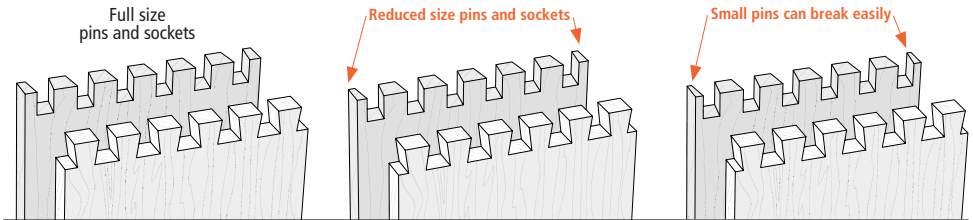

The EXACT width specified in the board width chart results in half-pins and sockets at each edge of the board.

When board width is reduced, the joint will have smaller, but equal sized pins and sockets at each edge of the board.

When the board width is reduced further, the result is very narrow and fragile pins at each edge of the board.

! IMPORTANT: Read the whole chapter before routing any boards.

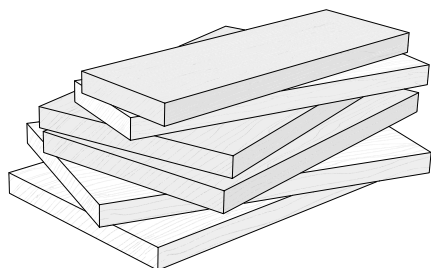

6-18 Making a Box

Prepare four similar boards $\frac{3}{4}$ " thick \times $7\text{-}1\frac{1}{2}$ " wide by about 12" long [19mm \times 191mm \times 305mm], and two test boards, $\frac{3}{4}$ " [19mm] thick by about 4" [100mm] wide.

Note: Boards of different thicknesses may also be joined.

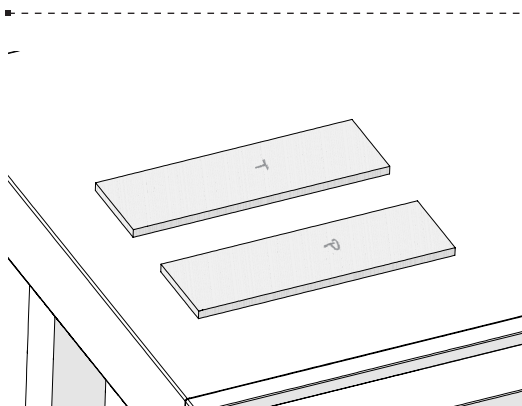

6-19 Routing a Test Fit Joint

The two test boards are used to establish joint fit before making the box.

Mark the outside face of one of the test boards with a "**T**" (tail board) and one with a "**P**" (pin board).

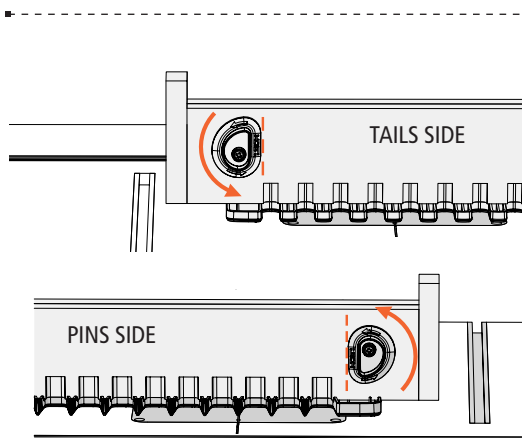

6-20 Turn both side stops until the straight edge is vertical and facing the middle of the jig.

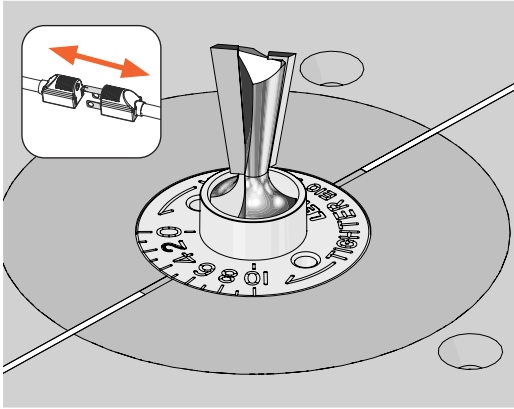

6-21 Rout the Test Tail Board

With the router unplugged, install the included 1/2" 8° dovetail bit and tighten the collet nut.

 The collet and bit must not touch the eBush or eBush nut. Rotate the collet to ensure both spin freely before reconnecting the power.

Ensure the eBush is set to 5.

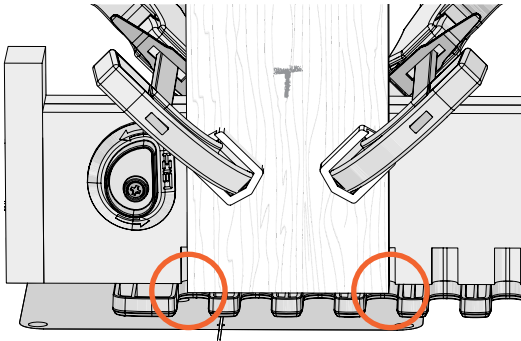

6-22 Place the test tail board on the jig leaving equal amounts of overhang on each board edge. Always position the board edge in the first template opening nearest the side stop.

Clamp the board in place.

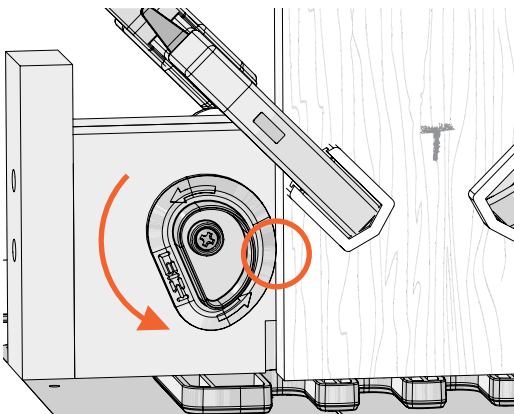

6-23 Rotate the side stop counter-clockwise until it touches the edge of the board. The side stop is now set to rout the test tail board.

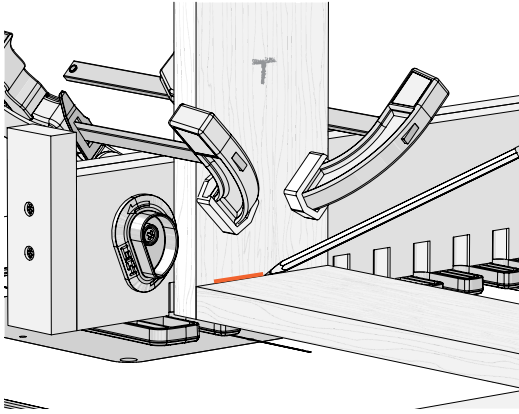

6-24 Pin and tail boards may differ in thickness. Always use the mating board to determine the depth of cut. Hold the test pin board flush against the template and draw a line on the tail board, indicating depth of cut.

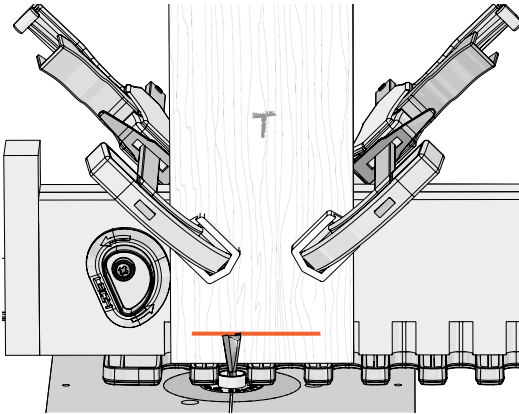

6-25 Adjust the tip of the bit until it's at the depth of cut line.

Rotate the collet to ensure it spins freely.

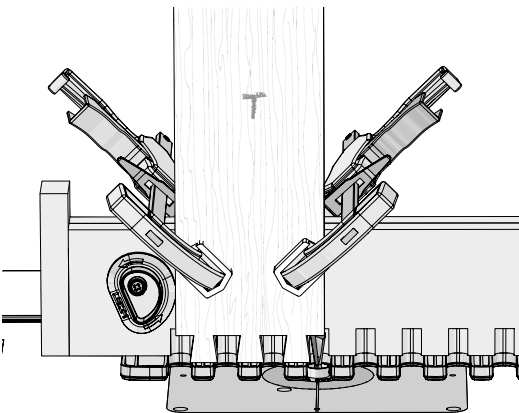

6-26 Hold the jig firmly and rout straight in and out of each template opening. Be sure the e10 guide bushing touches the left side of each template opening on the way in, and the right side on the way out. **Do not rotate the jig.**

Chips and sawdust can accumulate between the template openings. Check each routed slot to ensure it has been routed completely.

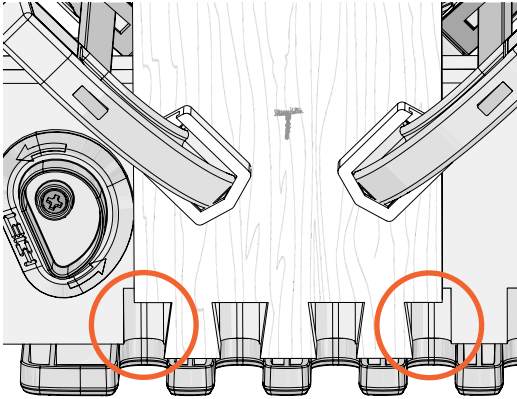

6-27 You will now have a half-pin socket at each board edge.

Do not remove the tail board as it is used to set the **PINS** side stop.

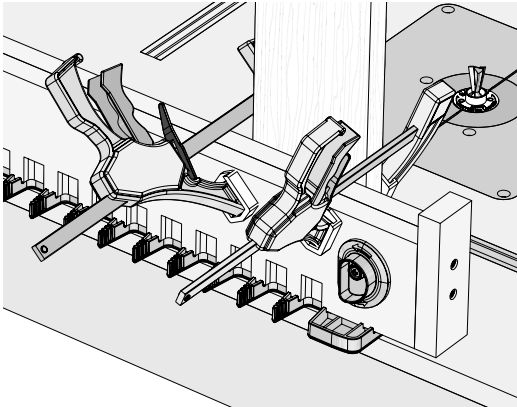

6-28 Position the jig so that the pin fingers overhang the edge of the router table.

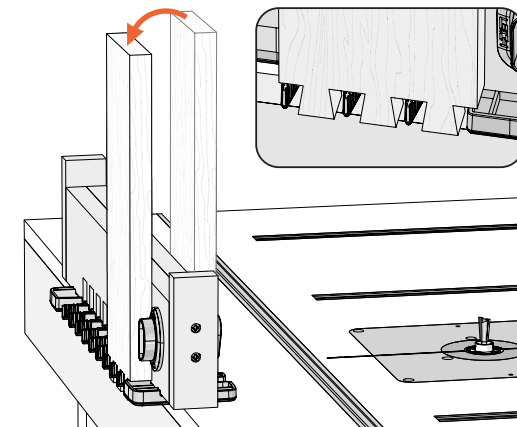

6-29 Unclamp the tail board. Keeping the same face toward you, move the tail board to the **PINS** side of the jig and fit the pin sockets over the pin fingers of the template.

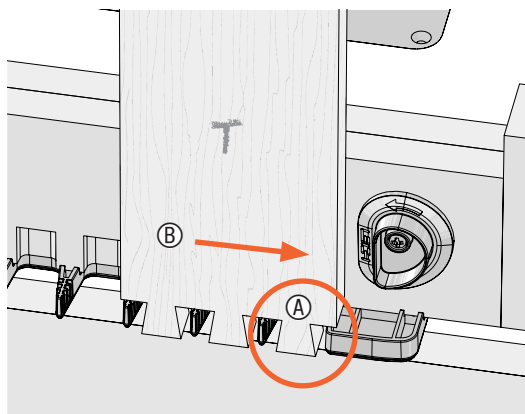

6-30 The leftmost tail should be in the first template opening closest to the side stop **A**.

There will be some slight play in the tail board. Hold the tail board firmly against the **PINS** side of the beam and the template, and move the board toward the side stop **B**.

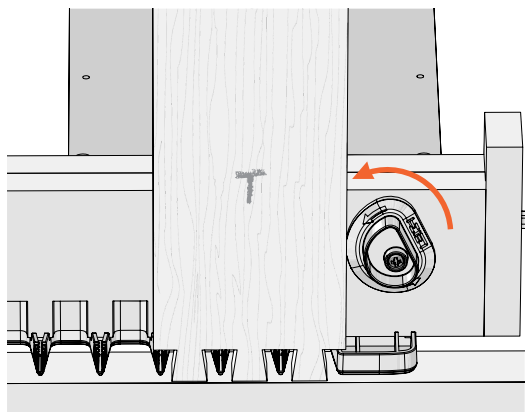

6-31 While holding the tail board firmly in place, rotate the side stop counter clockwise until it touches the edge of the board.

The side stop is now set to rout the test pin board.

Remove the tail board.

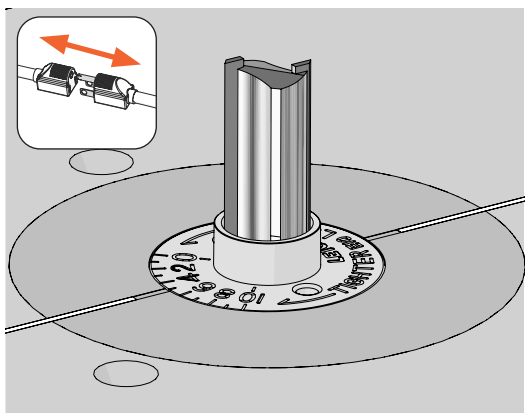

6-32 Rout the Test Pin Board

With the router unplugged, install the included 1/2" straight bit and tighten the collet nut.

⚠ The collet and bit must not touch the eBush or eBush nut. Rotate the collet to ensure both spin freely before reconnecting the power.

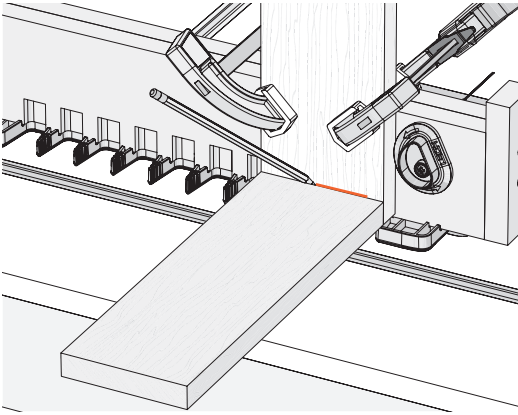

6-33 With the **PINS** side of the jig facing you, set the test pin board flush on the template with the edge against the side stop.

Clamp it in place.

Use the mating tail board to mark the depth of cut.

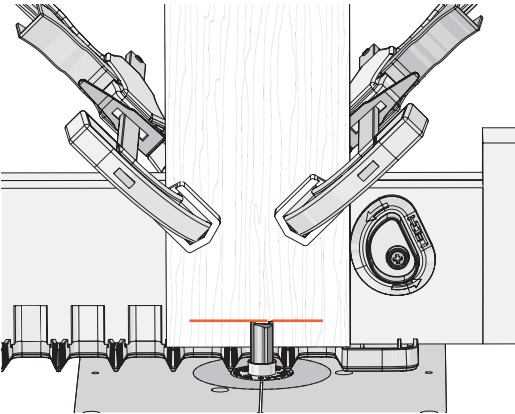

6-34 Adjust the bit until the tip is at the depth of cut line.

Rotate the collet to ensure it spins freely.

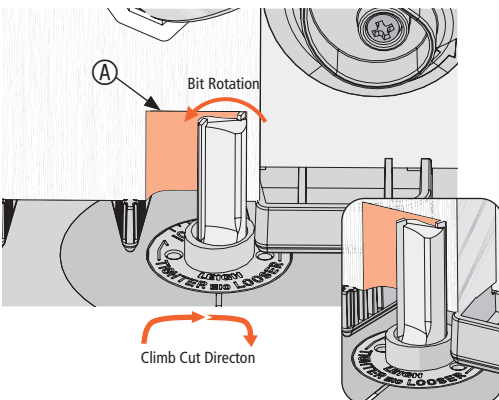

6-35 Make a Climb Cut When routing pins, you should always start with a shallow climb cut as this will produce a clean shoulder (A).

A climb cut may pull the jig to the right, so be sure to hold it firmly. Start on the right of the template opening and make a shallow cut as you move the jig to the right.

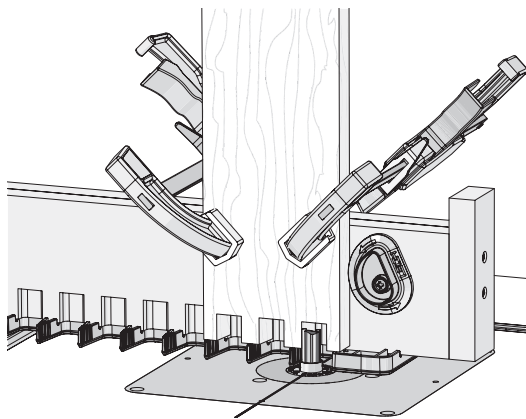

6-36 After making the climb cut, rout out the rest of the wood between the pins, in all template openings, along the width of the board.

Be sure the guide bushing touches both sides of the template opening.

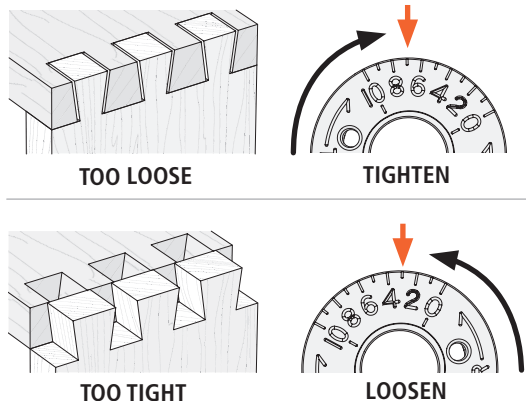

6-37 Joint Fit Adjustment

With the marked sides facing out, assemble the test boards. If the joint is too loose, use the pin wrench and turn the eBush to a higher number **and rout a new pin board.**

If the joint is too tight, turn the eBush to a lower number **and rout a new pin board.** One or two test cuts should produce the proper fit.

Re-tighten the eBush nut after each guide bushing adjustment.

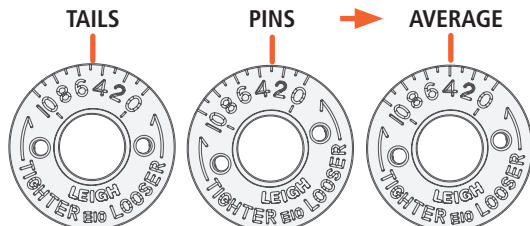

$$\text{Tails} + \text{Pins} = \text{Divided by } 2 =$$

$$5 + 3 = 8 \div 2 = 4$$

6-38 Once the fit is correct, add the two eBush settings together and divide by two. **Example:** 5 for tails, 3 for pins ($5 + 3 = 8$) ($8 \div 2 = 4$). Record setting “4” on an eBush diagram in the next step.

SAMPLE

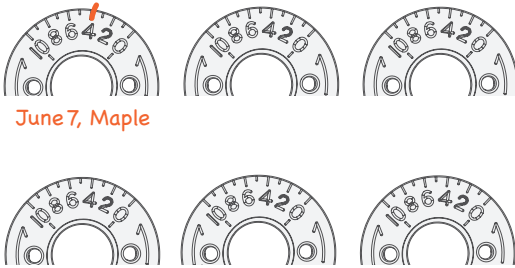

6-39 Use these eBush diagrams to record the settings you used to achieve perfect joint fit. The first eBush is an example of how to record your setting.

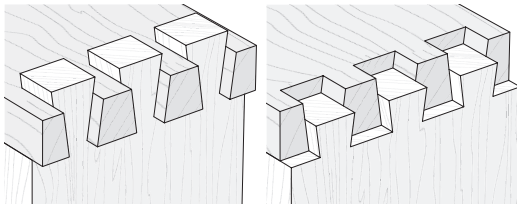

OVER FLUSH

UNDER FLUSH

6-40 Joint flushness is determined by the depth of cut.

If the joint is over flush, lower the bit to make a shallower cut.

If the joint is under flush, raise the bit to make a deeper cut.

Rout new test joints until fit and flushness are perfect before routing the final boards.

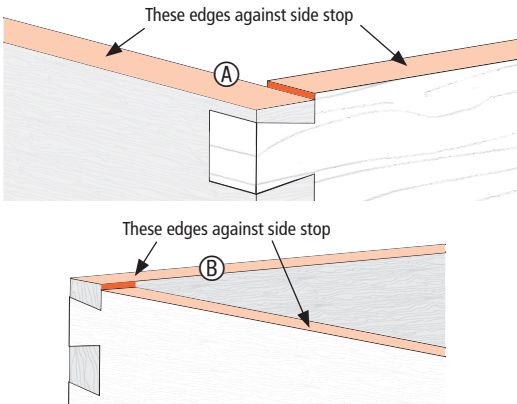

6-41 Joint Edge Flushness

If the edges of your joints are not flush, this could be due to bit concentricity issues.

The pin board edge that goes against the side stop might need to be raised **A** or lowered **B** slightly.

For instructions on bit concentricity adjustments, see Steps 5-33 to 5-44.

Note: The steps are the same, but the jig will be upside down.

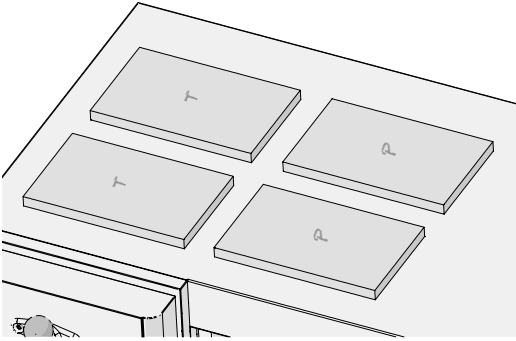

6-42 Making a Box

First establish the outside faces. Then lay out the four boards and mark the outside faces of two of the boards with a “**T**” (tail board) and two of the boards with a “**P**” (pin board).

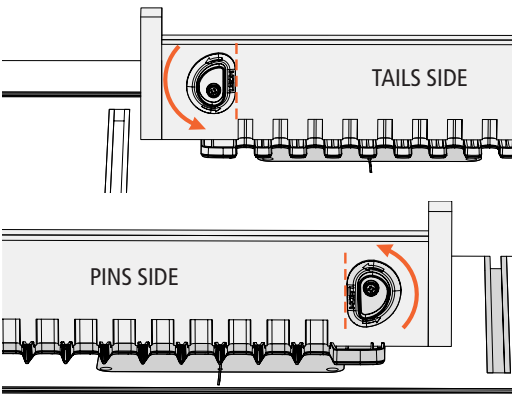

6-43 Turn both side stops until the straight edge is vertical and facing the middle of the jig.

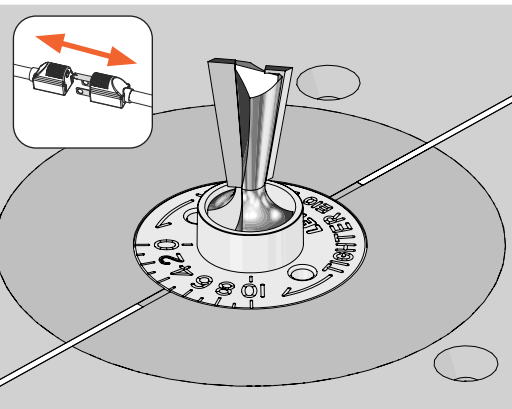

6-44 Routing the Tail Boards

Turn the eBush to the setting determined in the test joint.

With the router unplugged, install the 1/2" 8° dovetail bit and tighten the collet nut.

The collet and bit must not touch the eBush or eBush nut. Rotate the collet to ensure both spin freely before reconnecting the power.

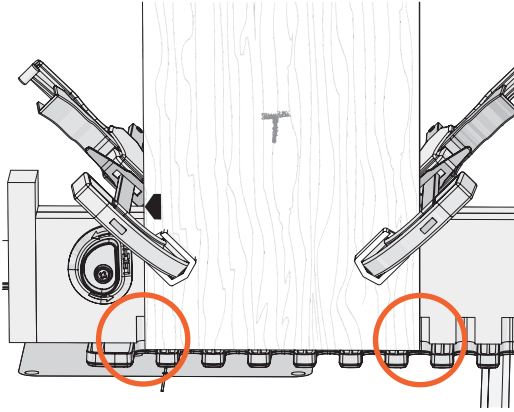

6-45 With the **TAILS** side of the jig facing toward you, position the tail board on the right side of the template, leaving equal amounts of overhang on each board edge.

Clamp the board in place.

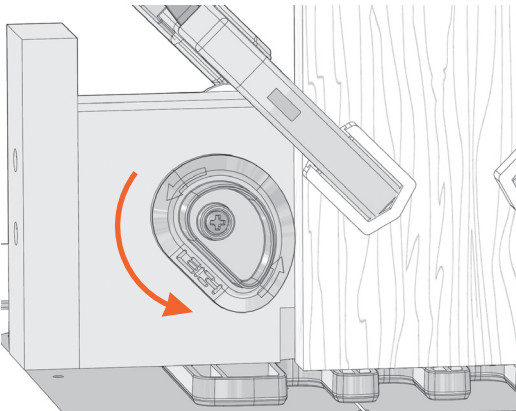

6-46 Rotate the side stop counter clockwise until it touches the edge of the board.

The side stop remains in place for all tail board routing.

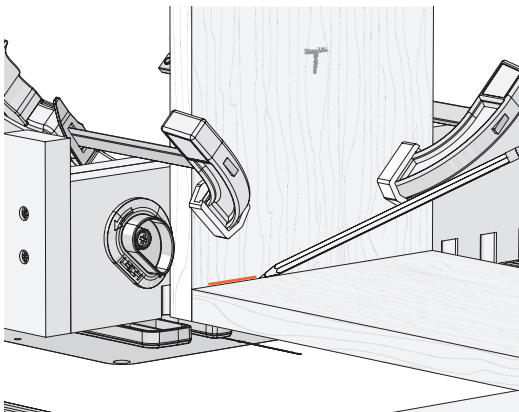

6-47 Hold a pin board flush against the template and draw a line on the tail board, indicating depth of cut.

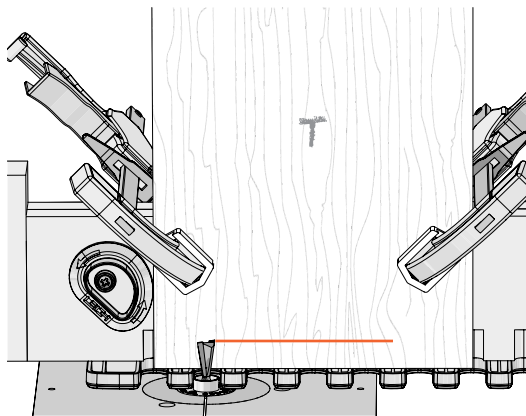

6-48 Adjust the bit until the tip is at the depth of cut line.

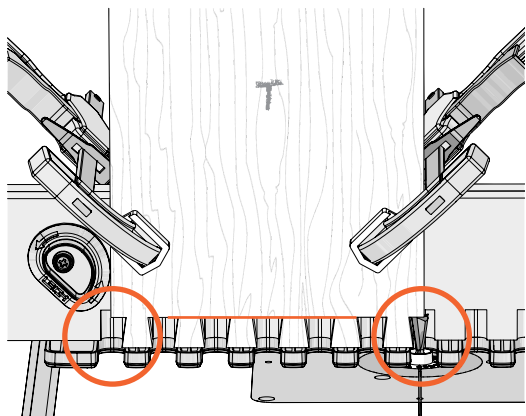

6-49 Hold the router firmly as you rout straight in and out of each template opening. The diameter of the guide bush is slightly smaller than the openings in the template, so be sure the guide bushing touches both sides of the template opening.

Do not rotate the jig.

There will now be a half-pin socket at each edge of the tail board.

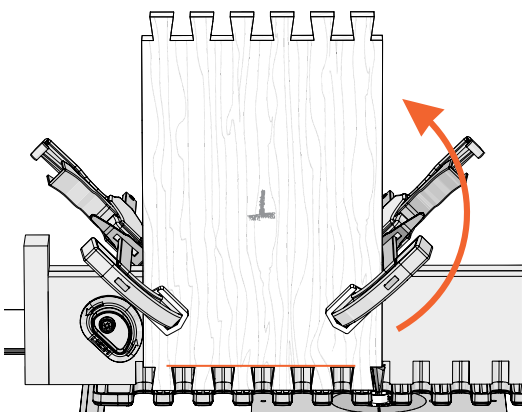

6-50 Unclamp the tail board. Keeping the same face toward you, rotate the board 180° and set it down flush on the template with the edge against the side stop.

Clamp it in place.

Rout the other end of the tail board and repeat for the second tail board.

Do not remove the tail board as it is used to set the **PINS** side stop.

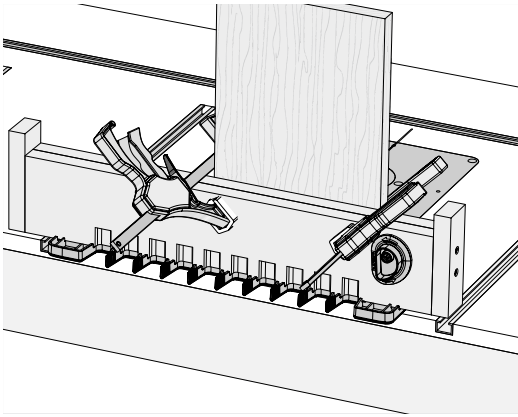

6-51 Position the jig so that the pin fingers overhang the edge of the router table.

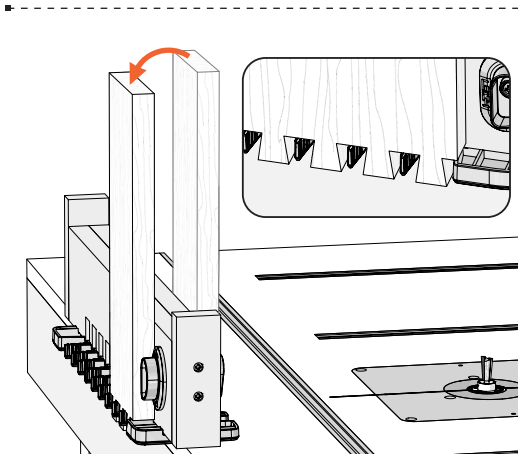

6-52 Unclamp the tail board.

Keeping the same face toward you, move the tail board to the **PINS** side of the jig and fit the pin sockets over the pin fingers on the template.

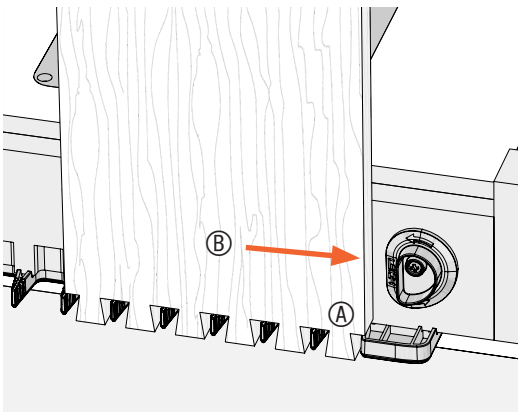

6-53 The leftmost tail should be in the first template opening closest to the side stop **(A)**.

There will be some slight play in the tail board. Move the board toward the side stop **(B)**.

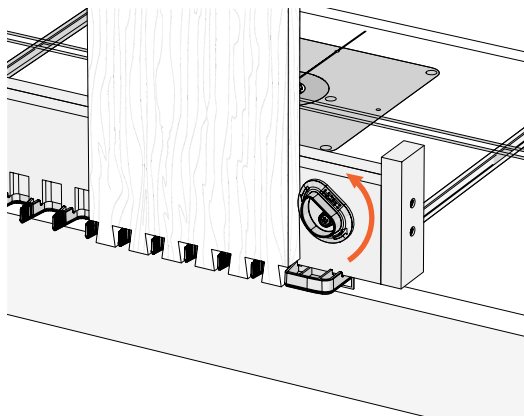

6-54 Hold the tail board firmly against the beam and rotate the side stop counter clockwise until it touches the edge of the board. The side stop is now set to rout the pin boards.

Remove the tail board.

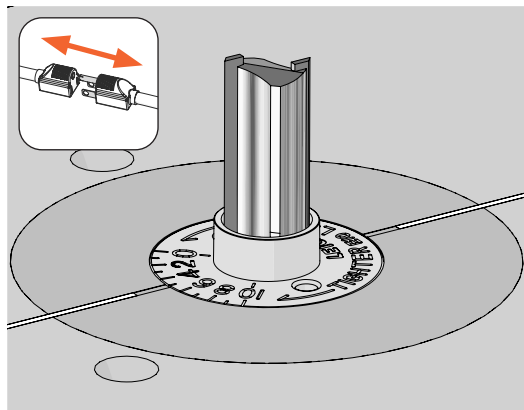

6-55 Routing the Pin Boards

Do not change the eBush setting.

With the router unplugged, install the included 1/2" straight bit and tighten the collet nut.

⚠ The collet and bit must not touch the eBush or eBush nut. Rotate the collet to ensure both spin freely before reconnecting the power.

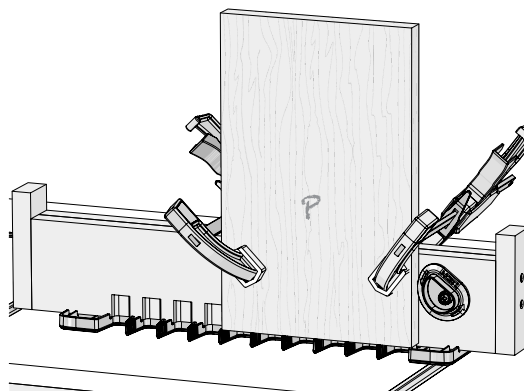

6-56 With the **PINS** side of the jig facing toward you, set the first pin board flush on the template with the edge against the side stop.

Clamp it in place.

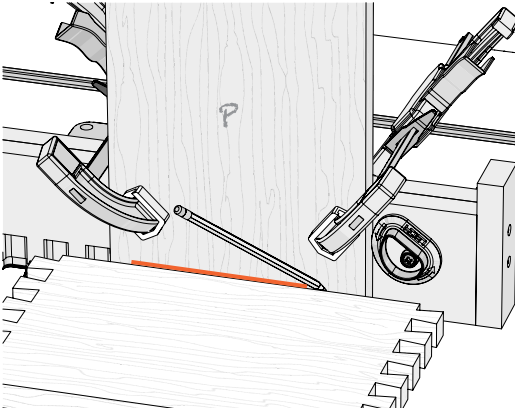

6-57 Hold a mating tail board flush on the template and draw a line indicating the depth of cut.

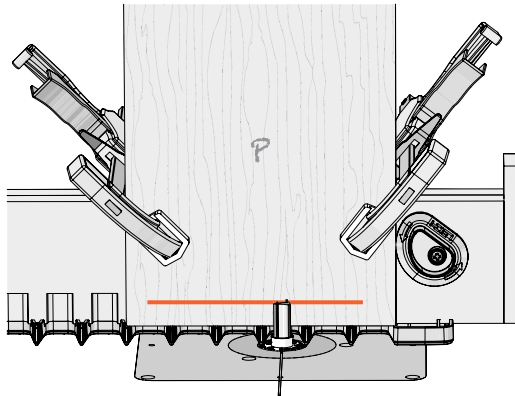

6-58 Adjust the bit until the tip is at the depth of cut line.

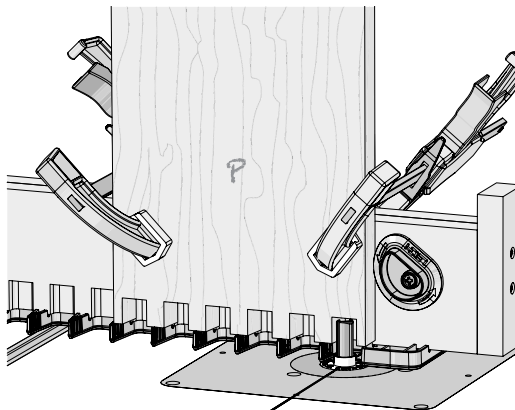

6-59 Hold the jig firmly and make a light climb cut (See Step 6-35).

Then rout out the rest of the wood between the pins, along the full width of the board.

Be sure the guide bushing touches both sides of the template opening.

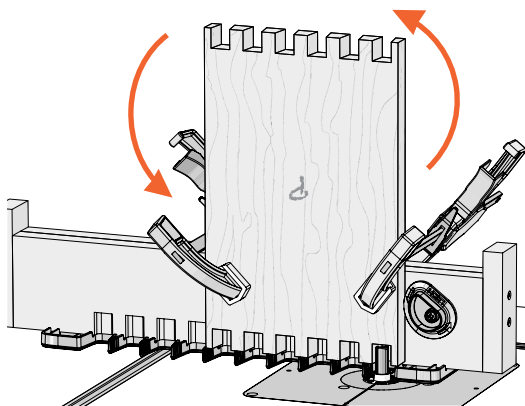
**6-60** Unclamp the pin board.

Keeping the same face toward you, rotate the board 180° and set it down flush on the template with the edge against the side stop.

Clamp it in place.

Rout the other end of the pin board and repeat for the second pin board.

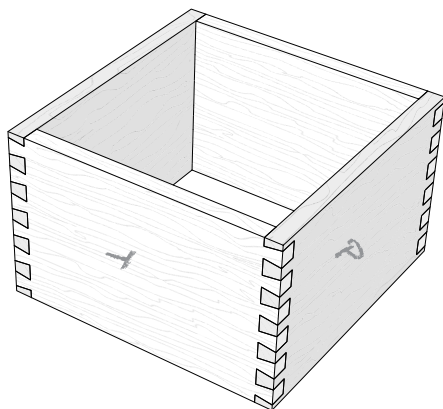
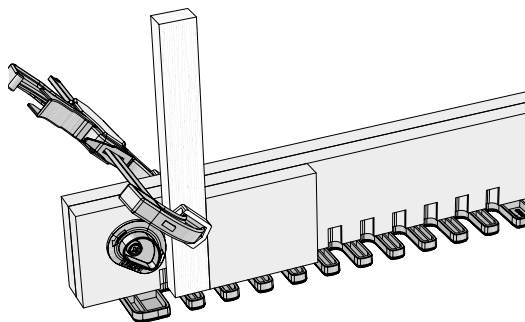
**6-61** Assemble the box keeping all marked board faces outward.**6-62 Clamping Narrow Boards**

See Steps 5-66 to 5-73 for narrow board clamping. ■