

TD330 User Guide

CHAPTER 5 Routing Through Dovetails

Note: The instructions in this chapter are based on using 3/4" [19mm] thick boards. Different board thickness may also be joined together.

IMPORTANT SAFETY NOTE

Before using your Leigh TD330, you must have completed the preparatory steps listed in the previous pages, including reading the jig safety recommendations in Chapter 2.



Watch the Online Instructional Video



Scan QR Code

Reduce your learning time dramatically!

Stream to your smart phone or tablet to use in your workshop while you're working. See Instructional Videos section in Support menu at leightools.com or scan QR code for instant video.

5-1 Watching the online video in addition to reading this user guide will reduce your learning time dramatically. The video can be streamed to your smart phone or tablet and used in your shop as a visual reference. Visit leightools.com and find the video in the Support section.

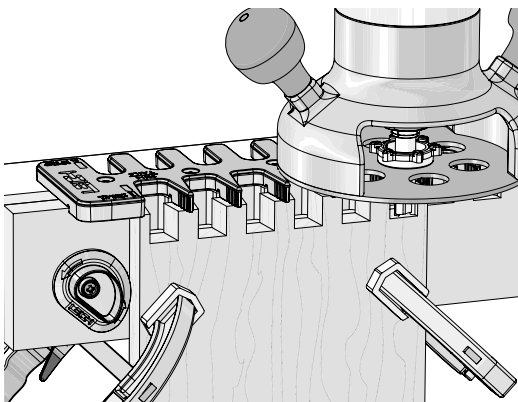

5-2 Getting Started The steps in this chapter show the jig used on a workbench. For router table operation, see Chapter 6.

5-3 Parts Required All through dovetails are routed with the included Leigh VM160CH 1/2" straight bit, Leigh VM80-500CH 1/2" 8° dovetail bit and the Leigh e10 guide bushing (eBush). **No other bit diameters, angles and guide bushing combinations may be used.** Maximum board thickness for through dovetail pin and tail boards is 13/16" [20,6mm]. Pin and Tail boards of different thicknesses may also be joined, up to a maximum of 13/16". **Note:** Optional 1/2" diameter spiral upcut bits may also be used.

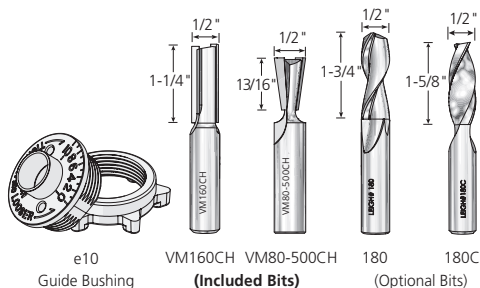

Bit Cutting Depth	
Bit Diameter	1/2"
Item No. Carbide Tipped	VM160CH
Item No. Carbide Tipped	VM80-500CH
Item No. Spiral HSS (Optional)	180
Item No. Spiral Solid Carbide (Optional)	180C
Depth of Cut	0"
	1/4"
	1/2"
	3/4"
	13/16"
	1"

5-4 Through Dovetail Terminology

- Ⓐ Pin
- Ⓑ Pin socket
- Ⓒ Half-pin
- Ⓓ Half-pin socket
- Ⓔ Tail
- Ⓕ Tail socket

The pins fit in the pin sockets. Joints should almost always have a half-pin at each side of the joint.

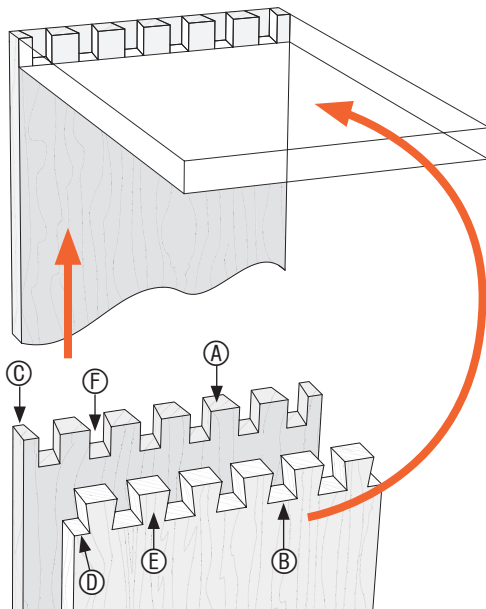

5-5 Board Width Selection Board widths are determined by the total number of full tails in the joint design. Use this chart to determine board widths up to 12-7/8" [327mm].

Board Width Selection for TD330											
No. of Tails		1	2	3	4	5	6	7	8	9	10
inches	Min	1 1/8	2 3/8	3 5/8	4 7/8	6 1/8	7 3/8	8 5/8	9 7/8	11 1/8	12 3/8
	Exact	1 1/4	2 1/2	3 3/4	5	6 1/4	7 1/2	8 3/4	10	11 1/4	12 1/2
	Max	1 5/8	2 7/8	4 1/8	5 3/8	6 5/8	7 7/8	9 1/8	10 3/8	11 5/8	12 7/8
No. of Tails		1	2	3	4	5	6	7	8	9	10
mm	Min	29	60	92	124	156	187	219	251	283	314
	Exact	32	64	95	127	159	191	222	254	286	318
	Max	41	73	105	137	168	200	232	264	295	327

5-6 Board Width Selection Board widths indicated in the EXACT column of the chart will produce **half-pins** at each board edge. Board widths may be increased by 3/8" [9,5mm] resulting in larger, but equally sized pins at each board edge. Similarly, board widths may be reduced by a maximum of 1/8" [3,2mm], resulting in smaller but equally sized pins at each board edge. Narrower widths may result in very small and weak pins at the edges of the pin board.

Symmetrical

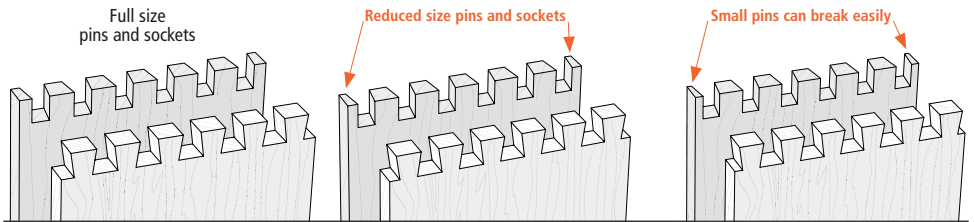

Width specified in the board width chart results in half size pins and sockets at each edge of the board.

When a symmetrical board width is reduced, the joint will have smaller, but equal sized pins and sockets at each edge of the board.

When the board width is reduced further, the result is very narrow and fragile pins at each edge of the board.

⚠ IMPORTANT: *Read this chapter before routing any boards.*

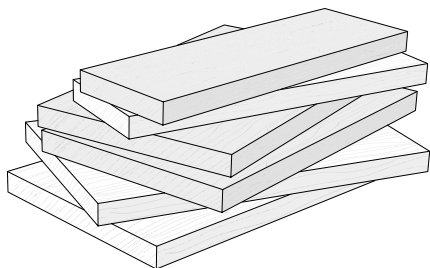

5-7 Making a Box

Prepare four similar boards 3/4" thick × 7-1/2" wide by 12" long [19mm×191mm×305mm], and two test boards, 3-3/4" [100mm] wide and the same thickness.

Note: Boards of different thicknesses may also be joined.

5-8 Routing a Test Fit Joint

The two test boards are used to establish joint fit before making the box.

Mark the outside face of one test board with a “**T**” (tail board) and the other one with a “**P**” (pin board).

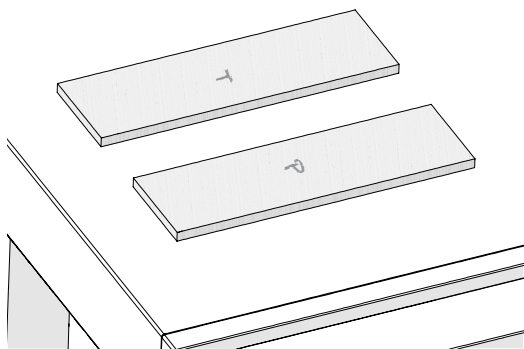

5-9 If you haven't already done so, install the e10 guide bushing in the router. See Steps 3-2 and 3-10 to 3-12. Test joints are always started with the eBush set at the 5 position.

Retighten the eBush nut after each guide bushing adjustment.

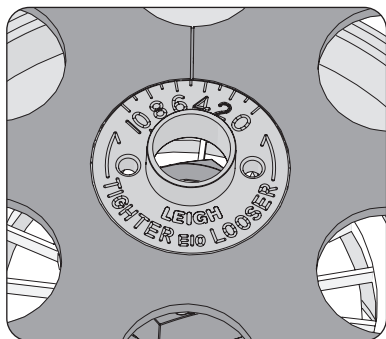

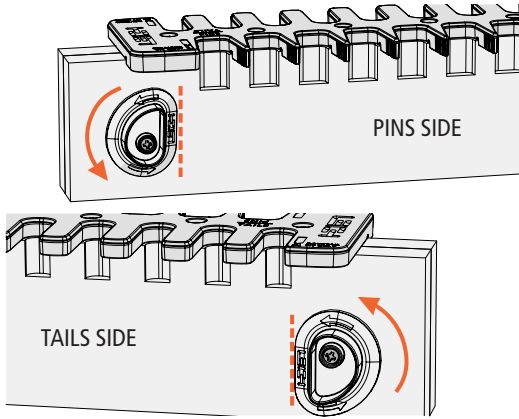

5-10 Turn both side stops until the straight edge is vertical and facing the middle of the jig.

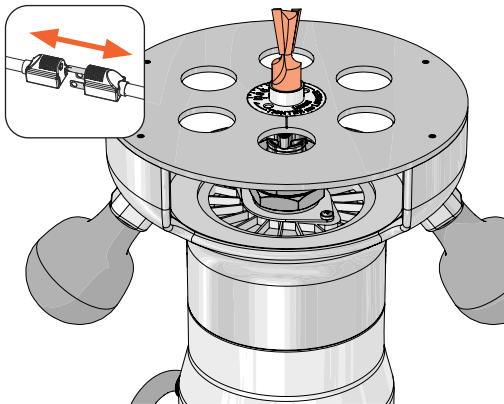

5-11 Tail boards are always routed first Unplug the router and install the 1/2" 8° dovetail bit. The bit goes through the guide bushing and fits in the router collet. Tighten the collet.

The collet and bit must not touch the eBush or eBush nut. Rotate the collet to ensure both spin freely.

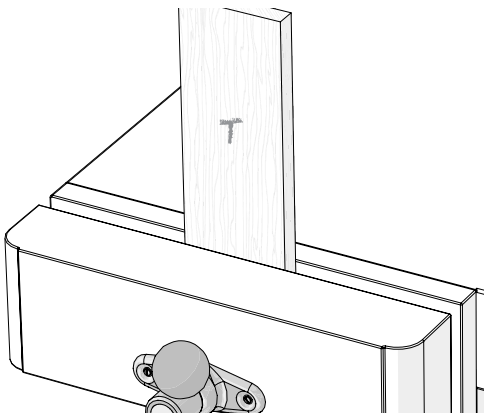

5-12 Clamp the test tail board in the vice with the "T" facing you.

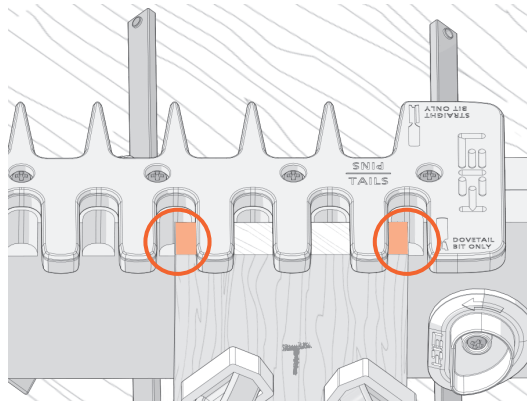

5-13 With the **TAILS** side of the jig toward you, position the right end of the jig over the test tail board, leaving equal amounts of the board showing at each edge, and clamp it in place.

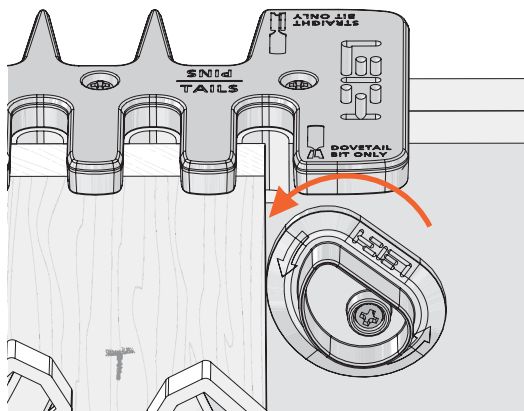

5-14 Set the **TAILS** Side Stop

Rotate the side stop counter clockwise until it touches the edge of the board.

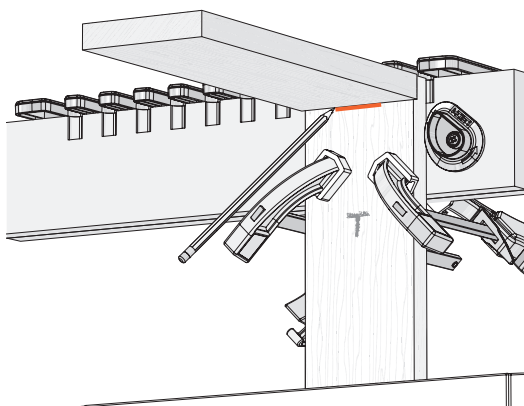

5-15 Pin and tail boards may differ in thickness. Always use the mating board to determine depth of cut. Hold the mating pin board flush under the template and mark a line on the tail board, indicating depth of cut.

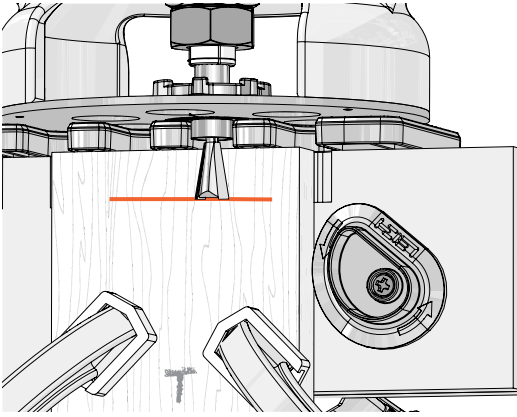

5-16 Place the router on the jig and adjust the dovetail bit until the tip is at the depth of cut line.

Rotate the collet to ensure it spins freely.

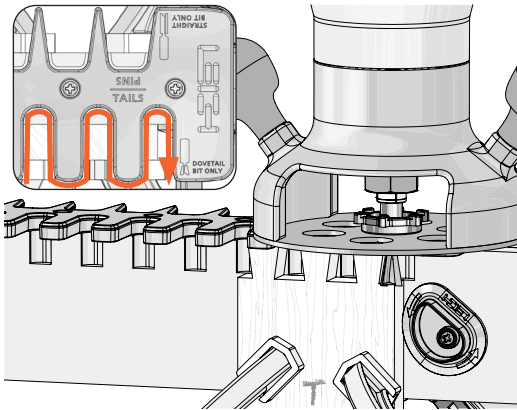

5-17 Rout the Test Tail Board

Hold the router firmly as you rout straight in and out of each template opening.

The diameter of the guide bush is slightly smaller than the openings in the template, so be sure the guide bushing touches both sides of the template opening.

Do not rotate the router.

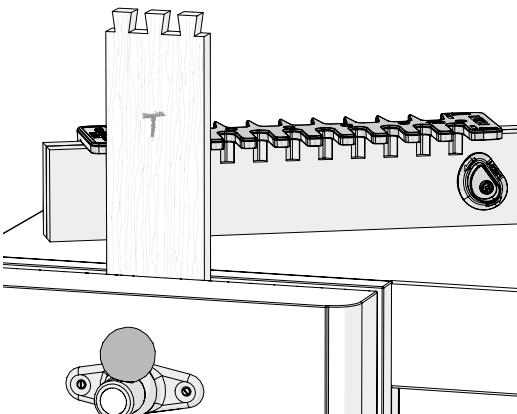

5-18 Remove the jig. There will now be a half-pin socket at each edge of the board.

Leave the tail board clamped in the vice as it used to set the **PINS** side stop.

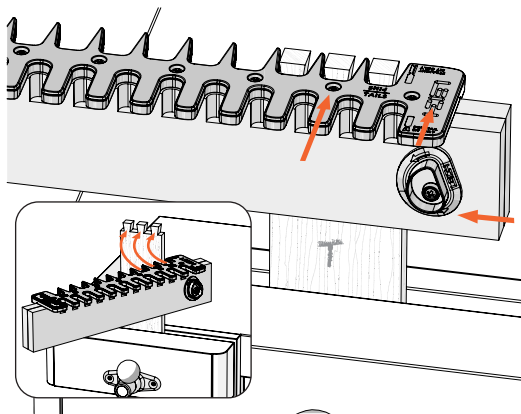

5-19 Set the PINS Side Stop

Leaving the tail board in the vice, insert the pin side of the template into the routed pin sockets. The rightmost tail should be in the first template opening closest to the side stop.

See 5-20 below which shows from the back side.

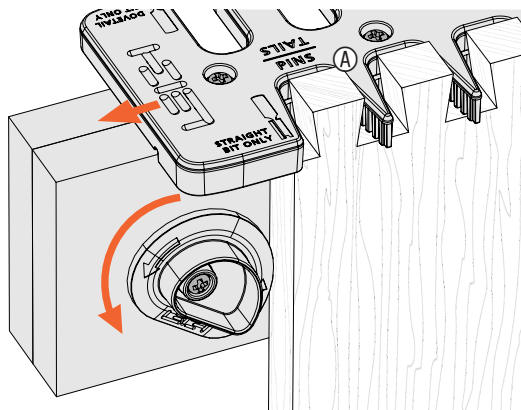

5-20 There may be slight play between the template pins and the tail board pin sockets. Hold jig firmly against tail board and move jig to the left until the play is eliminated (A).

While holding the jig firmly against the tail board, turn the side stop counter clockwise until it touches the board edge. The side stop is now set to rout the test pin board. Remove the jig and tail board.

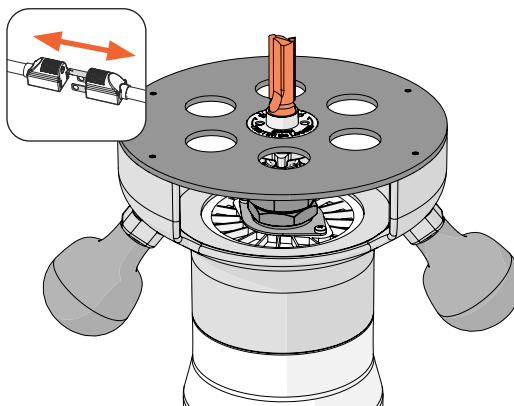

5-21 Rout the Test Pin Board

With the router unplugged, install the 1/2" straight bit. The bit goes through the guide bushing and fits in the router collet.

Tighten the collet.

The collet and bit must not touch the eBush or eBush nut. Rotate the collet to ensure both spin freely.

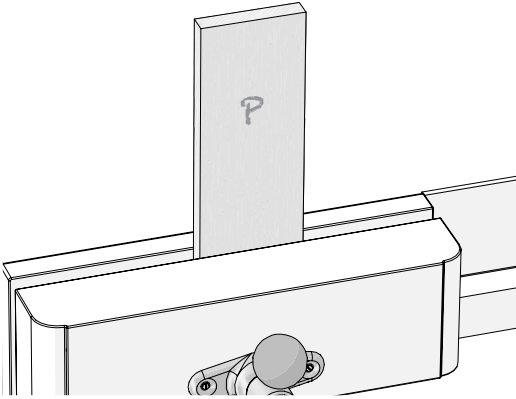

5-22 Clamp the test pin board in the vice with the outside (marked) face toward you.

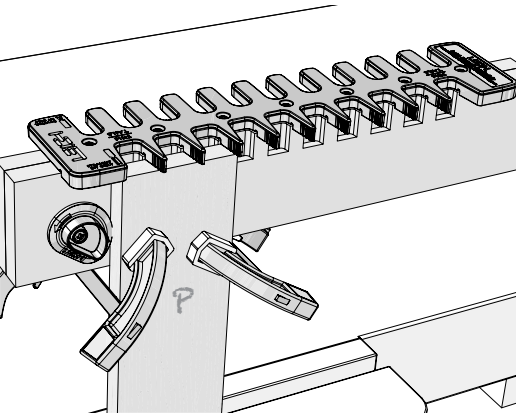

5-23 With the **PINS** side of the jig facing you, place it on the pin board and move it to the right until the side stop touches the board edge.

Clamp the jig in place.

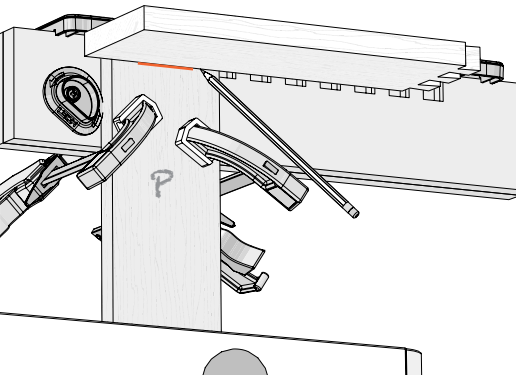

5-24 Always use the mating board to determine depth of cut. Hold the mating tail board flush under the template and mark a depth of cut line on the pin board.

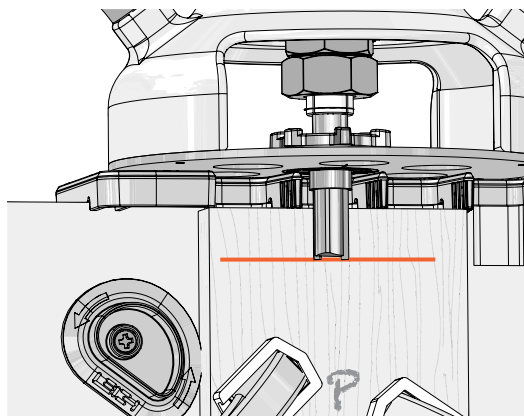

5-25 Place the router on the jig and adjust the bit until the tip is at the depth of cut line.

Rotate the collet to ensure it spins freely.

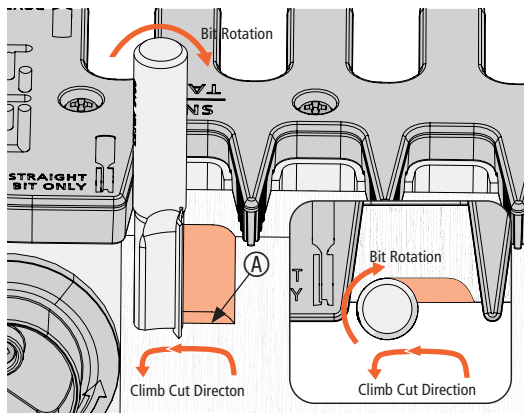

5-26 How to Make a Climb Cut

When routing pins, you should always start with a shallow climb cut, as this will create a clean shoulder (A).

A climb cut may pull the router to the left, so be sure to hold it firmly as you carefully make a shallow cut from right to left.

Note: For clarity the guide bushing is not shown.

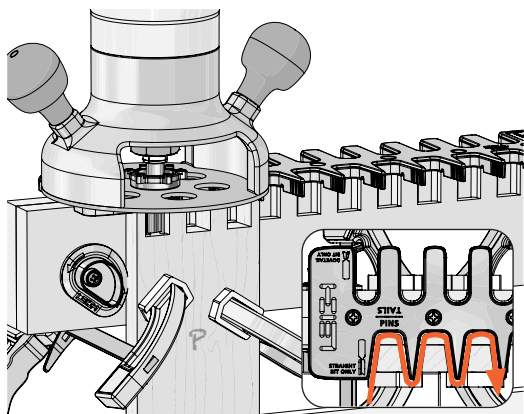

5-27 After making the climb cut, rout out the rest of the wood between the pins, in all template openings along the width of the board.

Be sure the e10 guide bushing touches the left side of the template opening on the way in, and the right side on the way out. **Do not rotate the router.**

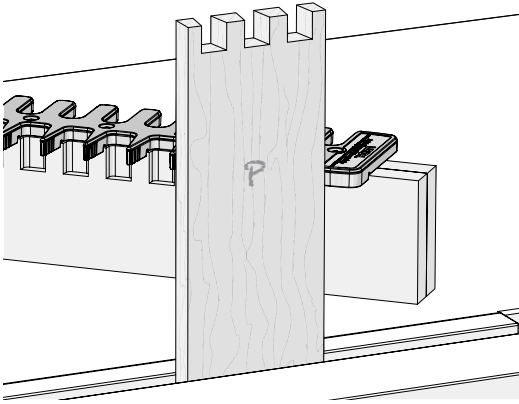

5-28 You will now have a half-pin on each edge of the board.

Do not adjust the side stops.

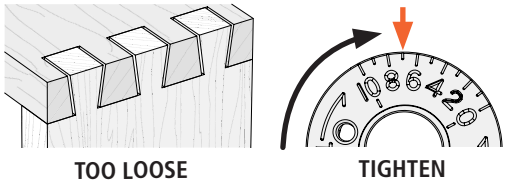

5-29 Joint Fit Adjustment

With the marked sides facing out, assemble the test boards. If the joint is too loose, use the pin wrench and turn the eBush to a higher number **and rout a new pin board.**

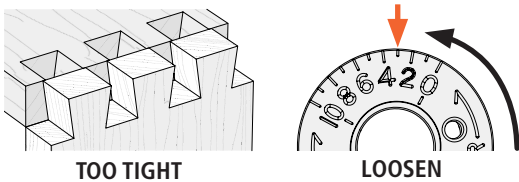

If the joint is too tight, turn the eBush to a lower number **and rout a new pin board.** One or two test cuts should produce the proper fit.

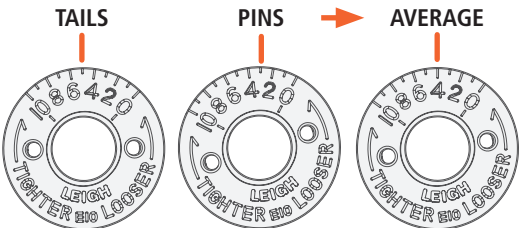

Tails + Pins = Divided by 2 =
 $5 + 3 = 8 \div 2 = 4$

5-30 Once the fit is correct, add the two eBush settings together and divide by two.

Example: 5 for tails, 3 for pins $(5 + 3 = 8)$ $(8 \div 2 = 4)$. Record setting “4” on an eBush diagram in the next step.

This will be the new eBush setting for **pins and tails** in all subsequent joints.

Re-tighten the eBush nut after each guide bushing adjustment.

SAMPLE

June 7, Maple

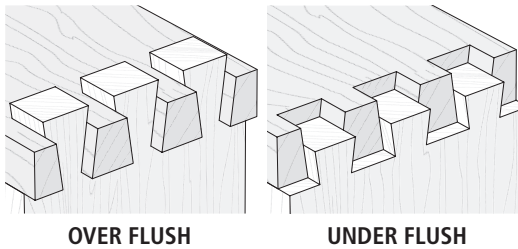

5-31 Use these eBush diagrams to record the settings you used to achieve a proper joint fit. The first eBush is simply an example of how to record your setting.

**OVER FLUSH****UNDER FLUSH**

5-32 Joint flushness is determined by the depth of cut.

If the joint is over flush, raise the bit to decrease the depth of cut.

If the joint is under flush, lower the bit to make a deeper cut.

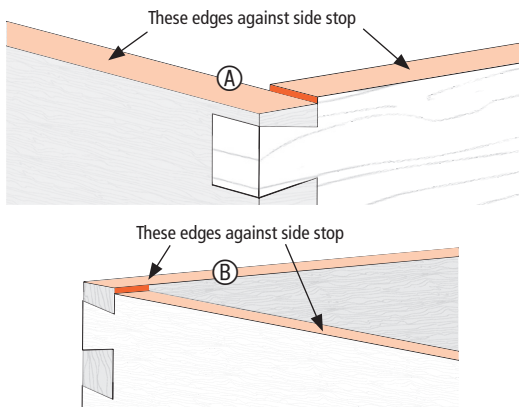

These edges against side stop

A

These edges against side stop

B

5-33 Joint Edge Flushness

If the edges of your joints are not flush, this could be due to bit concentricity issues.

The pin board edge that goes against the side stop might need to be raised **A** or lowered **B** slightly.

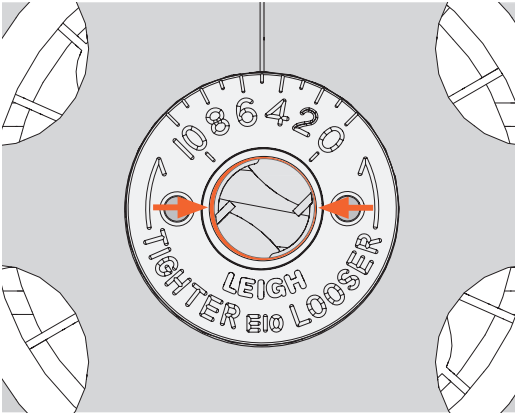

5-34 If each router bit is not centered in the guide bushing, the board edges may not be flush.

Some routers allow minor shifting of the router base plate to correct concentricity issues.

Otherwise, a slight adjustment to the **PINS** side stop can solve this problem.

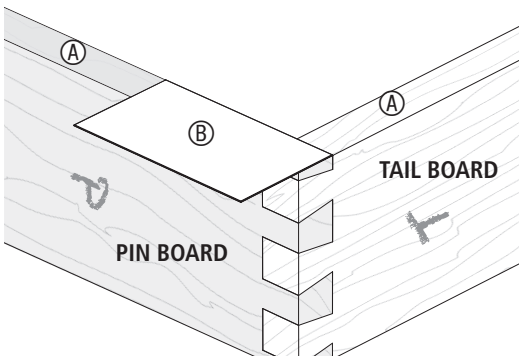

5-35 With the board edges that were against the side stops facing up **A**, use a feeler gauge, or something as simple as a business card **B** or two, to determine the amount of adjustment that is needed.

To raise the pin board edge, see Steps 5-36 to 5-40.

To lower the pin board edge, see Steps 5-41 to 5-44.

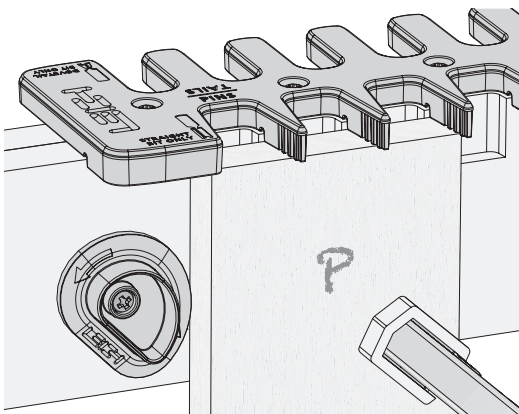

5-36 To raise the pin board edge clamp the jig to a new test pin board end with the edge against the side stop.

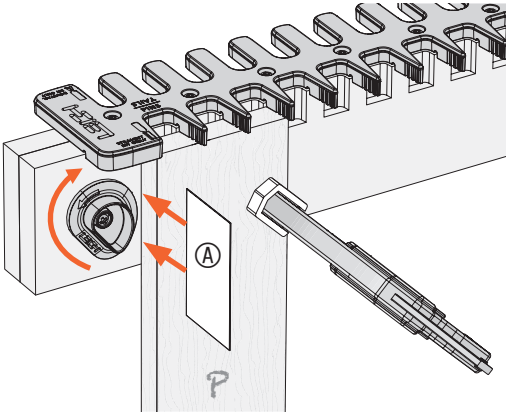

5-37 Rotate the side stop slightly clockwise and place the spacer **A** between the board edge and the side stop.

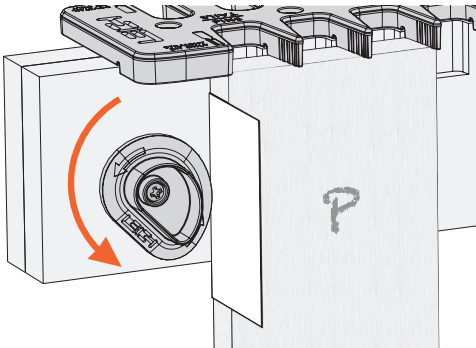

5-38 Then rotate the side stop counter-clockwise until it touches the spacer.

Remove the spacer and clamp.

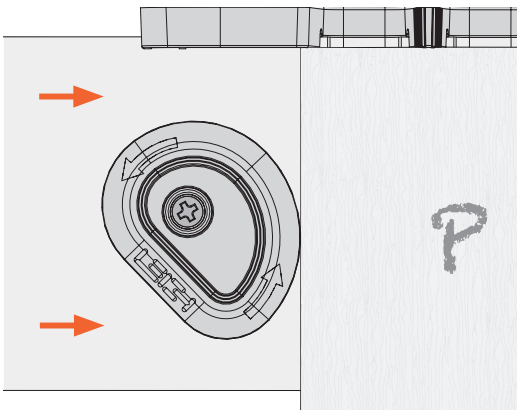

5-39 Shift the jig over until the side stop touches the board edge.

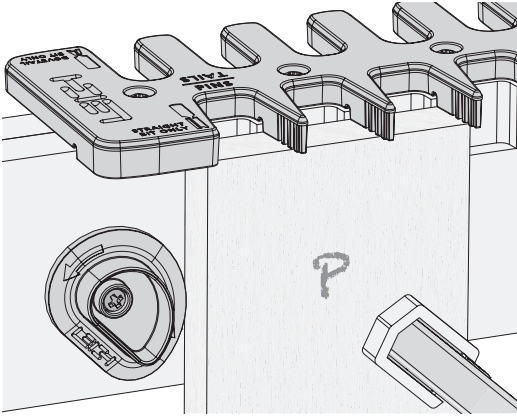

5-40 Clamp the jig in place.

Rout only a new test pin board end to fit in the test tail board. Test the edge flushness again and repeat the process until the edge flushness is correct.

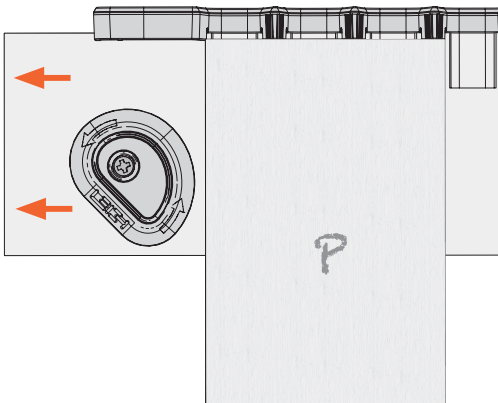

5-41 To lower the pin board edge, clamp a new test pin board end in the vice. Without adjusting the side stop, place the jig on top with a slight gap between the side stop and board edge.

Do not adjust the side stop yet.

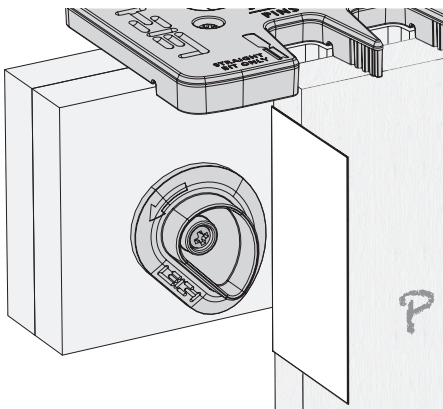

5-42 Place and hold the spacer between the side stop and board edge.

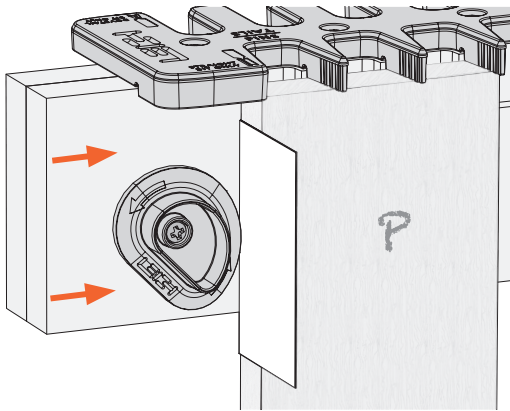

5-43 Shift the jig over until the side stop touches the spacer.

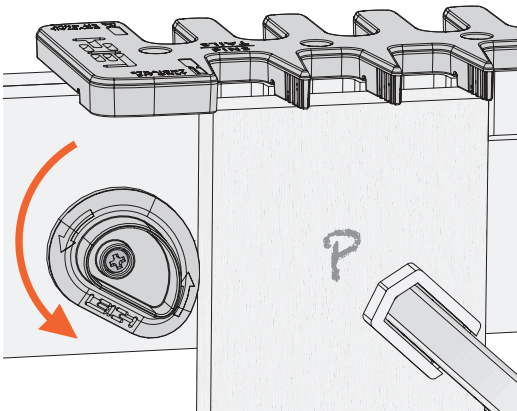

5-44 Clamp the jig in place, then remove the spacer and rotate the side stop counter clockwise until it touches the board edge.

Rout only a new test pin board end to fit in the test tail board. Test the edge flushness again and repeat the process until the edge flushness is correct.

5-45 Let's Make a Box

First establish the outside faces.

Lay out the four boards and mark the outside faces of two of the boards with a "T" (tail board) and the other two boards with a "P" (pin board).

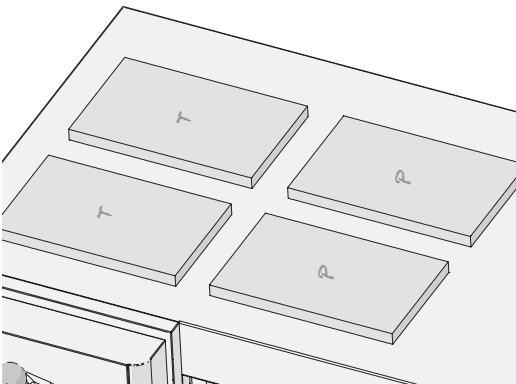

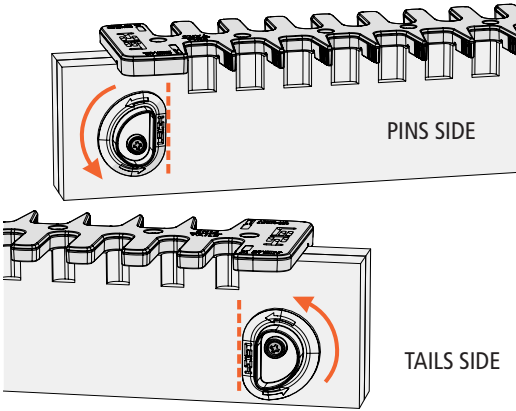

5-46 Turn both side stops until the straight edge is vertical and facing the middle of the jig.

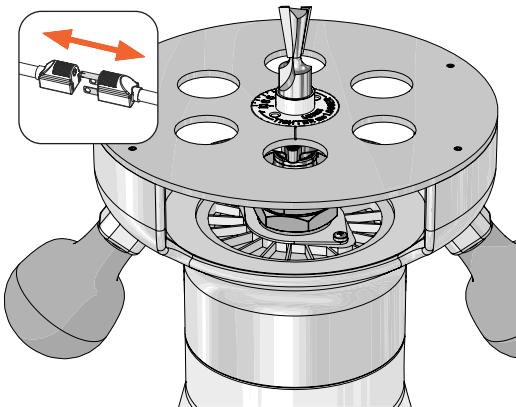

5-47 Routing the Tail Boards
With the router unplugged, install the 1/2" 8° dovetail bit.

The collet and bit must not touch the eBush or eBush nut. Rotate the collet to ensure both spin freely.

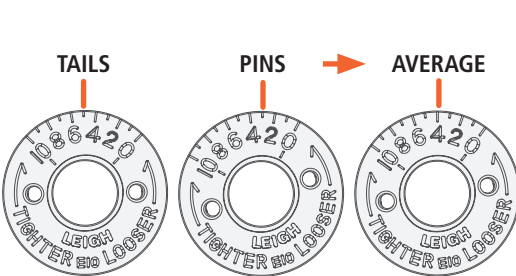

5-48 Set the eBush at the setting determined in **Step 5-30**. (Example shown.)

$$\text{Tails} + \text{Pins} = \text{Divided by } 2 =$$

$$5 + 3 = 8 \div 2 = 4$$

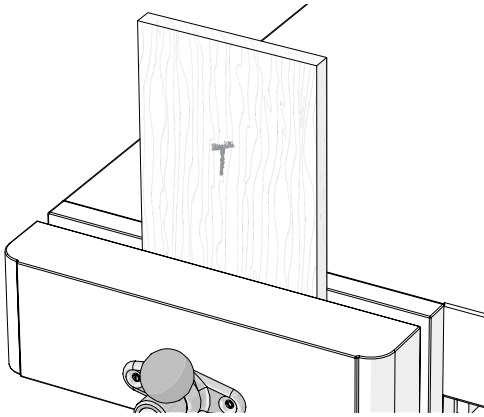

5-49 Clamp the first tail board in the vice with the marked face toward you.

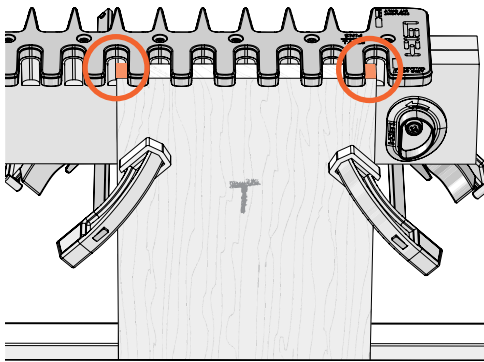

5-50 With the **TAILS** side of the jig facing you, position the right end of the jig over the tail board, leaving equal amounts of the board showing at each edge, and clamp it in place.

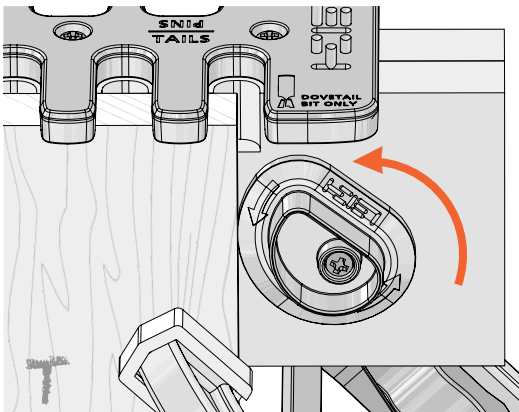

5-51 Rotate the side stop counter clockwise until it touches the edge of the board. The side stop is now set for all tail board routing.

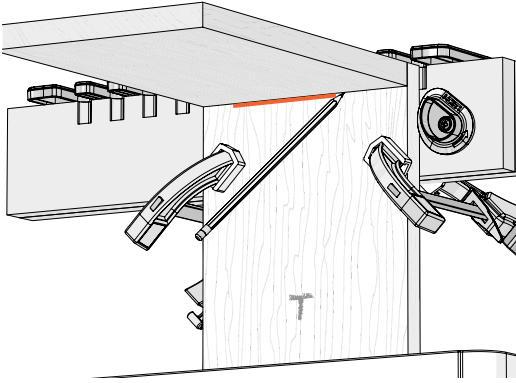

5-52 Place a pin board horizontally flush under the template and draw a depth of cut line on the tail board.

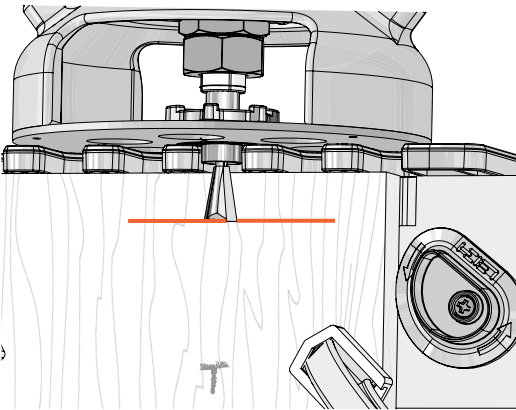

5-53 Place the router on the jig and adjust the bit until the tip is at the depth of cut line.

Rotate the collet to ensure it spins freely.

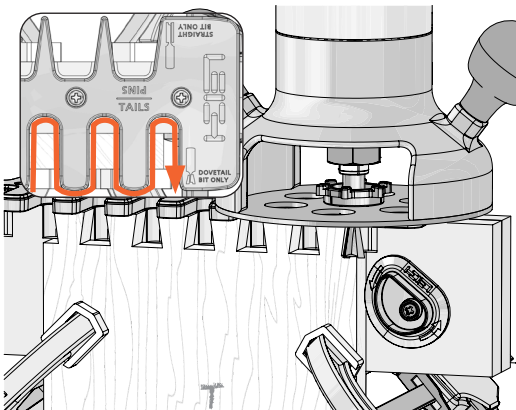

5-54 Hold the router firmly as you rout straight in and out of each template opening. The diameter of the guide bushing is slightly smaller than the openings in the template, so be sure the guide bushing touches both sides of the template opening.

Do not rotate the router.

There will now be a half-pin socket at each edge of the board.

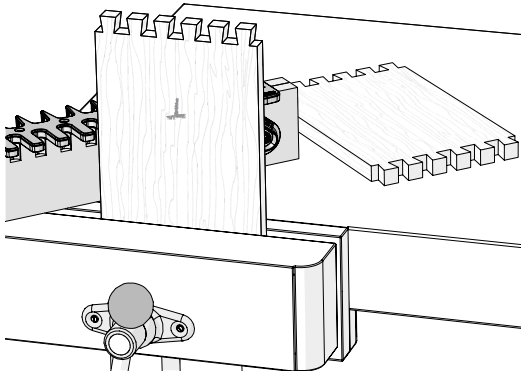

5-55 Unclamp the tail board, and keeping the same face toward you, rotate it end for end, and re-clamp in vice. Place jig on board with side stop against board edge. Clamp in place.

Rout the other end of the tail board and repeat the procedure on both ends of the second tail board.

Remove the jig, but leave the tail board in the vice, as it is used to set the **PINS** side stop.

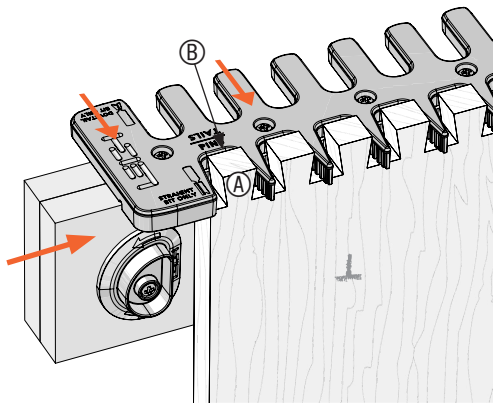

5-56 Set the PINS Side Stop

With the **PINS** side of the jig facing you, insert the template pin ends into the routed pin sockets. The leftmost tail **A** should be in the first template opening **B** closest to the side stop.

To eliminate any play between the pins of the template and the pin sockets of the tail board, hold the jig firmly against the back of the tail board and slide the jig to the right until the play is eliminated.

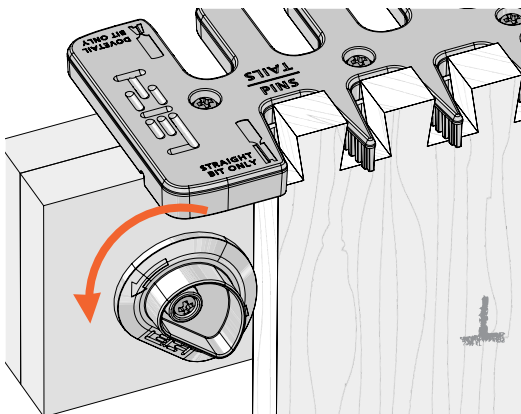

5-57 While holding the jig firmly in place, rotate the side stop until it touches the edge of the board.

The side stop is now set to rout the pin boards.

Remove the jig and tail board.

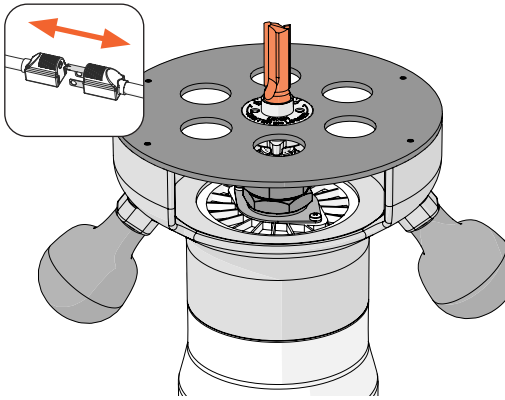

5-58 Routing the Pin Boards

Unplug the router and install the 1/2" straight bit. The bit goes through the guide bushing and fits in the router collet. Tighten the collet.

The collet and bit must not touch the eBush or eBush nut. Rotate the collet to ensure both spin freely.

Do not change the eBush setting.

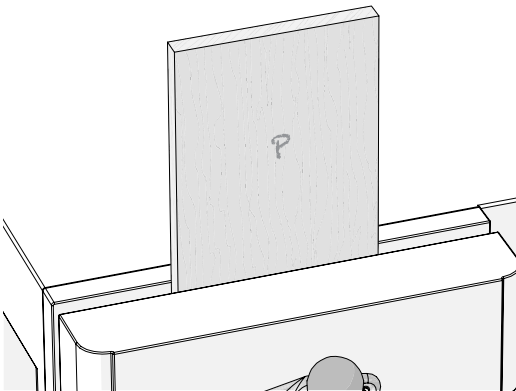

5-59 Clamp a pin board in the vice with the outside face toward you.

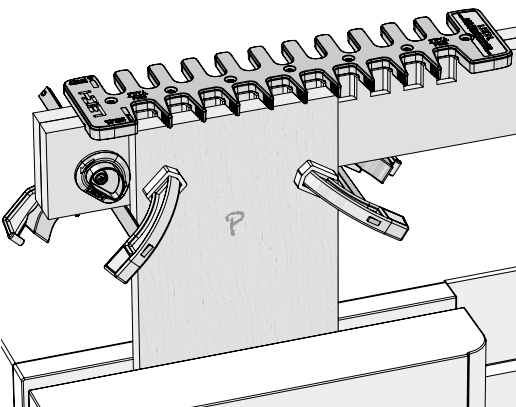

5-60 With the **PINS** side facing you, lower the jig on the board and move it to the right until the side stop touches the left edge of the board. Clamp the jig in place.

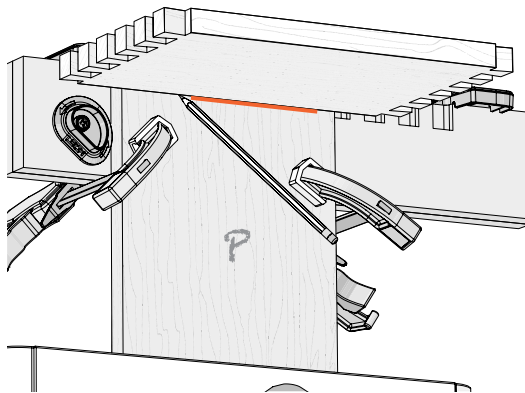

5-61 Place a tail board horizontally flush under the template and draw a depth of cut line on the pin board.

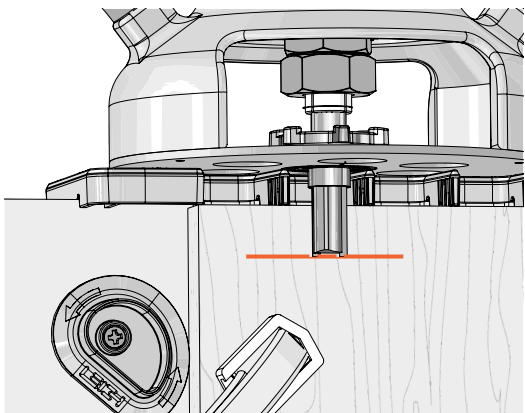

5-62 Place the router on the jig and adjust the bit until the tip is at the depth of cut line. Rotate the collet to ensure it spins freely.

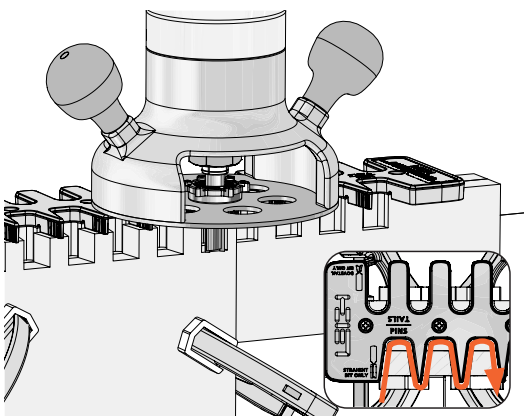

5-63 Hold the router firmly and make a shallow climb cut from right to left between the pins. (See Step 5-26).

Then rout out the remaining wood between the pins. Be sure the e10 guide bushing touches the left side of the template opening on the way in, and the right side on the way out.

Do not rotate the router.

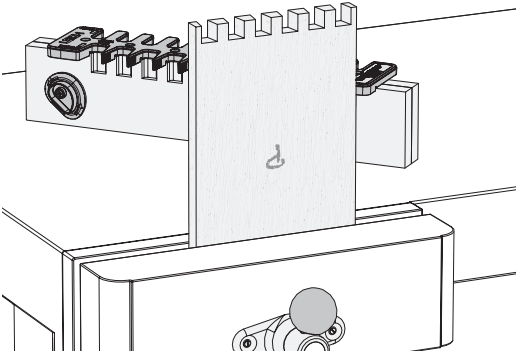

5-64 Unclamp the pin board, and keeping the same face toward you, rotate it end for end, and re-clamp it in the vice.

Rout the second end.

Repeat the procedure on the second pin board.

All four boards are now complete.

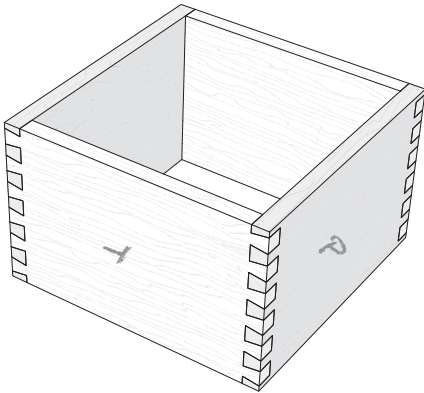

5-65 Assemble the box keeping all marked board faces outward.

Note: Any pin board end will fit any tail board end.

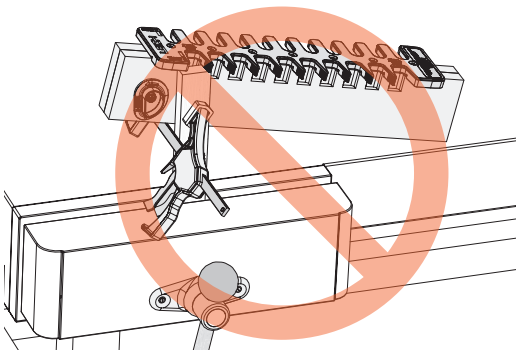

Clamping Narrow Boards

5-66 When working with narrow boards it may only be possible to use one clamp, meaning the jig cannot be held securely in place.

5-67 It may be necessary to support the beam to ensure secure clamping.

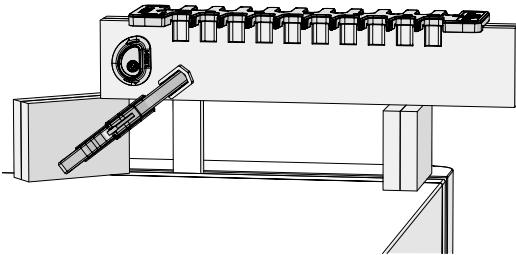

5-68 The jig can be supported using two wood blocks of the same height. The purpose of the blocks is to provide room for the clamp and to keep the jig level.

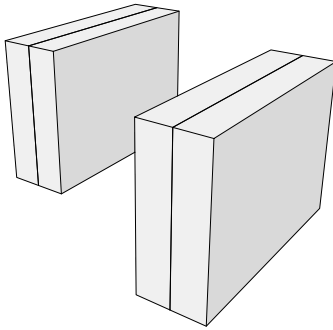

5-69 Place the jig upside down and rotate both side stops until the straight edge is vertical and facing the middle of the jig.

Place the narrow board **A** on the **TAILS** side of the jig and center it on the first template finger, closest to the side stop.

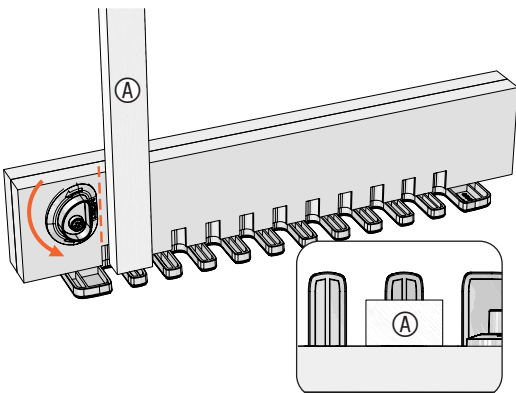

5-70 The narrow workpiece must be perpendicular to the jig.

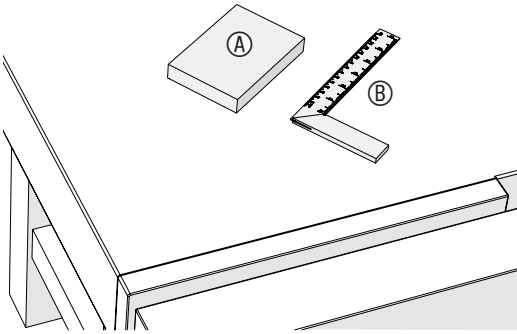

Use a square MDF block (A) or square (B) to align the tail board with the jig template.

5-71 While holding the tail board over the first finger, use the MDF block (A) or Square (B) on the template and against the tail board.

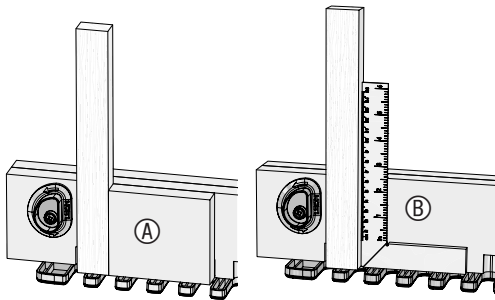

The tail board will now be perpendicular to the template.

5-72 Clamp the tail board to the jig.

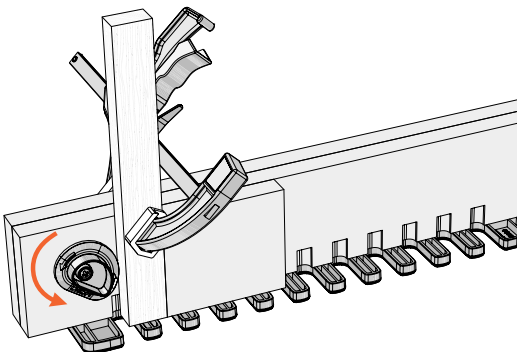

Turn the side stop counter clockwise until it touches the board edge.

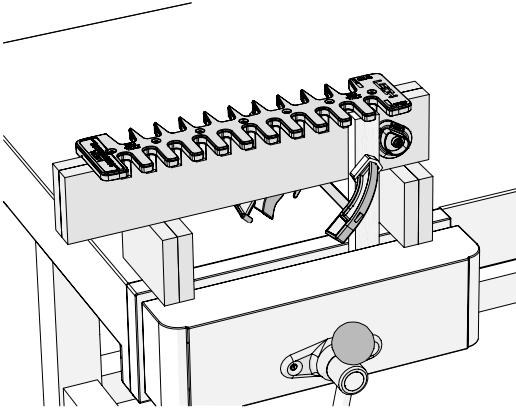

5-73 Remove the square or block and place the tail board in the vice with the beam resting on the blocks. Tighten the vice.

The jig is now held securely in place.

Use the square or block to align the other end of the tail board and the pin boards. ■