

# **LEIGH RTJ400**

*16" Router Table Dovetail Jig*

# **User Guide**

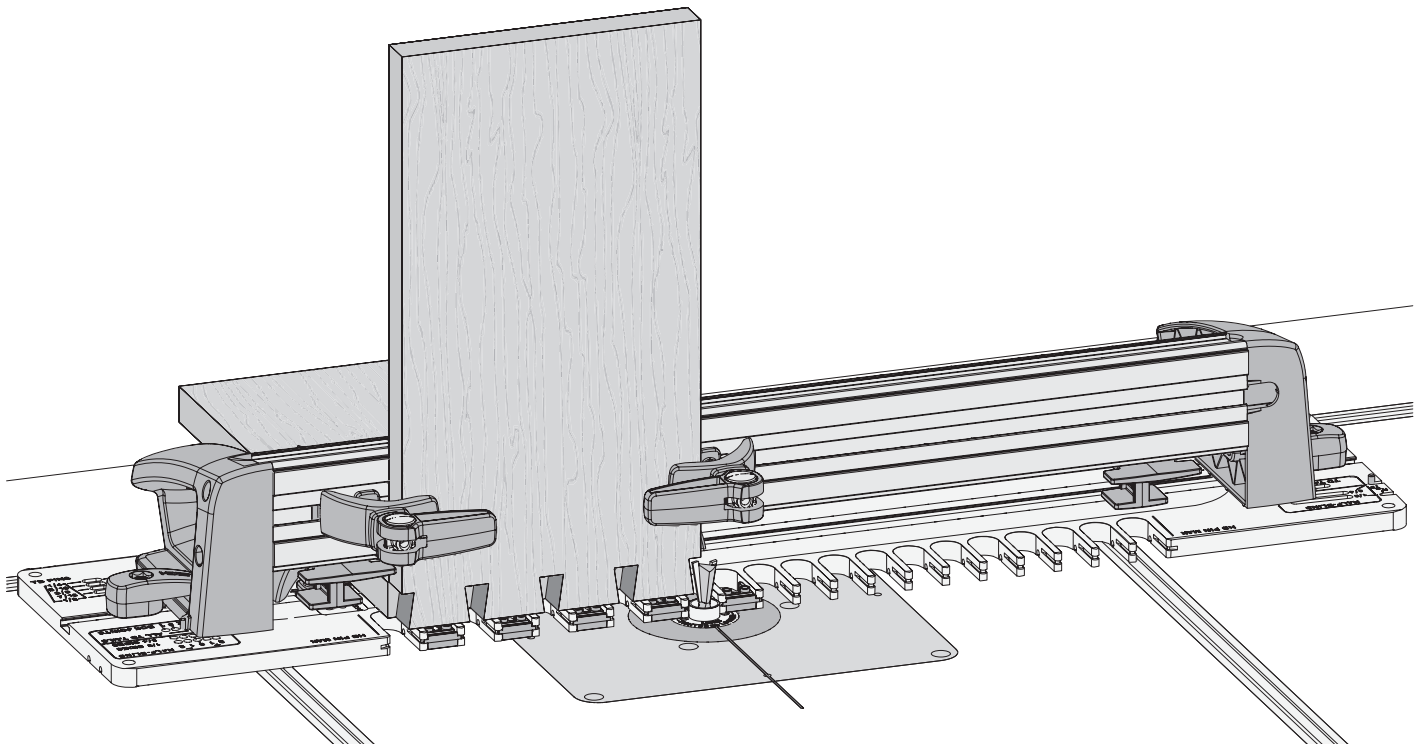

Dedicated Customer Support  
**1-800-663-8932**



## Your New Leigh RTJ400 Router Table Dovetail Jig for Through Dovetails, Half-Blind Dovetails and Box Joints

The RTJ400 was designed for the ever increasing use of router tables in shops everywhere. The RTJ400 can produce sizes and types of joints not possible with typical template jigs, including through dovetails, half-blind dovetails and box joints (finger joints), and thanks to the patented Leigh eBush, perfect fitting joints are guaranteed every time.

### Customer Support

If you have any questions that are not answered in this user guide, please call Leigh Customer Support: **1-800-663-8932** in North America or email: [help@leighjigs.com](mailto:help@leighjigs.com). For support contacts in your country of purchase, see Customer Support, Chapter 15. Leigh user guides are updated as required. A downloadable pdf of the latest version can be found on the Support page at [leighjigs.com](http://leighjigs.com).

*Reminder: If at first you don't succeed, read the instructions!*

## Contents

	<b>Introduction</b>	2
	Jig Features	3
	Bit Specifications	4
	Accessory Kit for the RTJ400	5
	Router Table Requirements	6
Chapter 1	<b>Assembling the RTJ400</b>	7
Chapter 2	<b>Glossary of Symbols</b>	11
Chapter 3	<b>Using your Jig Safely</b>	13
Chapter 4	<b>Basic Jig Functions</b>	15
Chapter 5	<b>Wood Preparation</b>	19
Chapter 6	<b>The Leigh eBush</b>	21
Chapter 7	<b>Through Dovetails</b>	23
Chapter 8	<b>Half Pitch Through Dovetails</b>	29
Chapter 9	<b>Half-Blind Dovetails</b>	35
	Rabbeted Half-Blind Dovetails	40
Chapter 10	<b>3/8" Box (Finger) Joints</b>	43
	3/8" Half-Blind Box Joints	48
Chapter 11	<b>3/4" Box (Finger) Joints</b>	53
Chapter 12	<b>3/16" Box (Finger) Joints</b>	59
Chapter 13	<b>3/32" Box (Finger) Joints</b>	65
Chapter 14	<b>Jig Parts</b>	71
Chapter 15	<b>Customer Support</b>	73
Chapter 16	<b>Quick Reference</b>	74
	Board Width Selection	74

### Important! Inches and Millimeters

Text and illustrations in this English language user guide indicate dimensions in both inches and millimeters, where applicable, with "inches" first, followed by "millimeters" in square brackets, i.e. ½" x 2"[12mm x 50mm].

**Do not be concerned that the inch/millimeter equivalents are not mathematically "correct". Just use the dimensions that apply to your guides and bits.**

The RTJ400 is covered by the following patent: U.S. Patent No. 8,534,329  
Patents for all Leigh elliptical guide bushings: U.S. 8,256,475 UK GB2443974

### Watch the Online Instructional Video

**The online video will reduce your learning time dramatically!** Stream to your smart phone or tablet to use in your shop as a visual reference. Find the video in the Instructional Videos section of the Support menu.



Dedicated Customer Support  
**1-800-663-8932**

### IMPORTANT Jig Design Update

The drawings in this user guide show an earlier version of the jig handles (A). The handles now have two protrusions to protect the pin (B). The functionality remains the same.

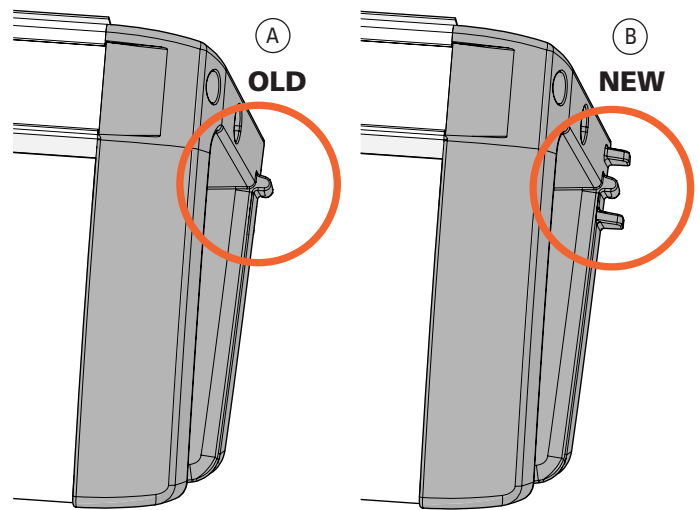

Overhead view of old and new handles.

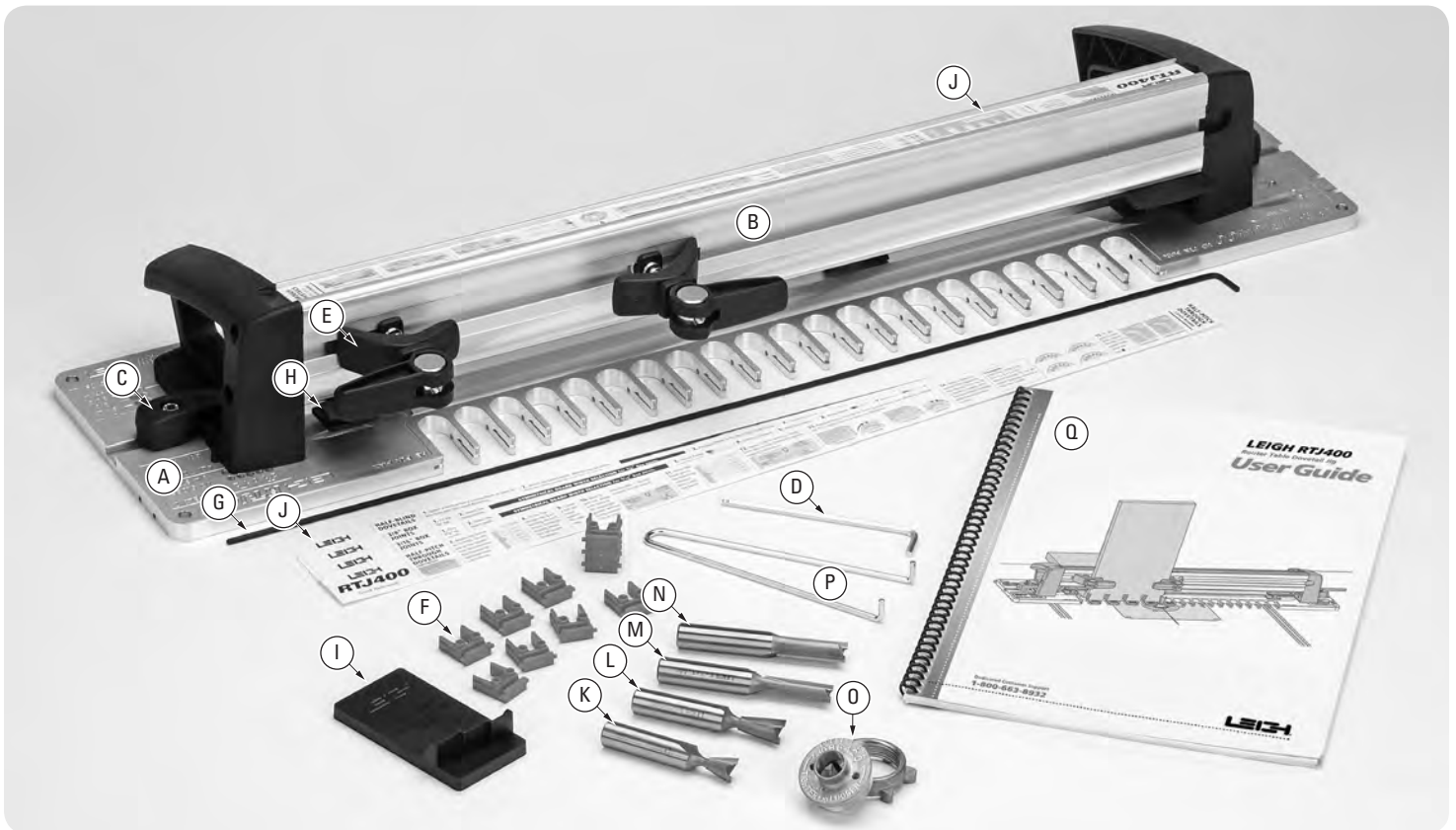

## RTJ400 Jig Features and Parts

See complete list of jig parts in Chapter 14.

**If any of these parts are missing from your jig, please notify your supplier or Leigh immediately. See Chapter 15, Customer Support.**

- Ⓐ **Jig Template**, CNC machined, with holes and slots to position the frame, and precision guides for routing tails, pins & sockets
- Ⓑ **Jig Frame**, CNC machined, with pins that fit into template holes & slots
- Ⓒ **Frame Latches**, 2, to secure jig frame to jig template
- Ⓓ **Hex Key**, 1/8" Ball End
- Ⓔ **Cam-Action Speed-Clamps**, 4, for mounting workpieces to jig
- Ⓕ **Blockers**, 10, inserted in template guide openings to prevent routing
- Ⓖ **Stop Rod**, inserted in template holes to limit cutting depth
- Ⓗ **Side stops**, 2, for mounting workpieces; adjustable for all joint types
- Ⓘ **Bit Depth Gauge**, for setting cutting depth on half-blind dovetails
- Ⓙ **Instruction Strips**, 5, for quick reference; inserted in jig top
- Ⓚ **Dovetail Bit 120-500**, 1/2" x 1/2" x 14°
- Ⓛ **Dovetail Bit 80-500**, 1/2" x 13/16" x 8°
- Ⓜ **Straight Bit 143-500**, 3/8" x 1-1/4"
- Ⓝ **Straight Bit 160**, 1/2" x 1-1/4"
- Ⓞ **Guide Bushing**, e10 Elliptical eBush, for perfect joint fit
- Ⓟ **Pin Wrench**, to adjust e10 eBush
- Ⓠ **User Guide**, Fully Illustrated

### You will need:

- A router table that accepts standard size (1-3/8" OD) guide bushings

**Note:** See page 6 for instructions on fitting the Leigh eBush to your router table.

## Bits for the RTJ400

This chart shows all bits available for the RTJ400.

RTJ400 BIT SPECIFICATIONS												
Leigh Bits	A Bit Diameter	B Max. Cutting Depth	C Shank Diameter	D Shank Length	E Overall Length	F Angle	Use with Collet/Collet Reducer	Full Pitch Through Use with Straight Bit	Use with e-Bush	Half Pitch Through Use with Straight Bit	Use with e-Bush	
<b>Through Dovetails</b>												
<b>50-8</b> Carbide Tipped	1/4"	1/4"	8mm	1-3/4"	2"	8°	8mm collet or 172-8 collet reducer	160 180 180C	e10	140-8 170 170C	e7 & e10	
<b>60-8</b> Carbide Tipped	5/16"	3/8"	8mm	1-3/4"	2-1/8"	8°	8mm collet or 172-8 collet reducer	160 180 180C	e10	140-8 170 170C	e7 & e10	
<b>70-8</b> Carbide Tipped	3/8"	1/2"	8mm	1-3/4"	2-1/4"	8°	8mm collet or 172-8 collet reducer	160 180 180C	e10	140-8 170 170C	e7 & e10	
<b>75-8</b> Carbide Tipped	7/16"	5/8"	8mm	1-3/4"	2-3/8"	8°	8mm collet or 172-8 collet reducer	160 180 180C	e10	140-8 170 170C	e7 & e10	
<b>80-500*</b> Carbide Tipped	1/2"	13/16"	1/2"	1-3/4"	2-3/4"	8°	1/2" collet	160 180 180C	e10	-	-	
<b>140-8</b> Carbide Tipped	5/16"	1-1/4"	8mm	1-3/4"	2-3/4"	Straight	8mm collet or 172-8 collet reducer	-	e7	-	-	
<b>170*</b> High Speed Steel	5/16"	1"	8mm [5/16"]	1-3/4"	3"	Straight	8mm collet or 172-8 collet reducer	-	e7	-	-	
<b>170C*</b> Solid Carbide	5/16"	1-1/4"	8mm [5/16"]	1-3/4"	2-3/4"	Straight	8mm collet or 172-8 collet reducer	-	e7	-	-	
<b>160*</b> Carbide Tipped	1/2"	1-1/4"	1/2"	1-3/4"	3"	Straight	1/2" collet	-	e10	-	-	
<b>180*</b> High Speed Steel	1/2"	1-1/4"	1/2"	1-3/4"	3-1/2"	Straight	1/2" collet	-	e10	-	-	
<b>180C*</b> Solid Carbide	1/2"	1-1/4"	1/2"	1-3/4"	3-1/2"	Straight	1/2" collet	-	e10	-	-	
<b>Half-Blind Dovetails</b>												
<b>112-500</b> Carbide Tipped	1/2"	19/32"	1/2"	1-3/4"	2-9/16"	12°	1/2" collet	-	e10	-	-	
<b>120-500*</b> Carbide Tipped	1/2"	1/2"	1/2"	1-3/4"	2-1/2"	14°	1/2" collet	-	e10	-	-	
<b>128-500</b> Carbide Tipped	1/2"	3/8"	1/2"	1-3/4"	2-3/8"	18°	1/2" collet	-	e10	-	-	
<b>Box Joints</b>												
<b>163</b> High Speed Steel	3/32"	3/8"	1/4"	2"	2"	Straight	1/4" collet	-	e10	-	-	
<b>166*</b> High Speed Steel	3/16"	5/8"	1/4"	1-3/4"	2-7/8"	Straight	1/4" collet	-	e10	-	-	
<b>166C*</b> Solid Carbide	3/16"	5/8"	1/4"	1-3/4"	2-1/2"	Straight	1/4" collet	-	e10	-	-	
<b>143-500*</b> Carbide Tipped	3/8"	1-1/4"	1/2"	1-3/4"	3-1/4"	Straight	1/2" collet	-	e10	-	-	
<b>173-500*</b> High Speed Steel	3/8"	1-1/4"	1/2"	1-3/4"	3-3/4"	Straight	1/2" collet	-	e10	-	-	
<b>173-500C*</b> Solid Carbide	3/8"	1-1/4"	1/2"	1-3/4"	3"	Straight	1/2" collet	-	e10	-	-	

\*Bits 80-500, 160, 120-500 & 143-500 come with the RTJ400

\*Spiral upcut bits rout cleaner and faster, leaving a smoother finish



**172-8**  
1/2" to 8mm collet reducer  
1 1/4" long. For 8mm shank bits

## Accessory Kit for the RTJ400 (ACRTJ)

This optional kit offers great savings over individual prices, and opens up a world of possibilities. Available from leighjigs.com

### The ACRTJ includes:

#### Through Dovetail Bits

Carbide tipped, 8°, 8mm shank, for through and half pitch through dovetail tails

- 50-8** 1/4" bit
- 60-8** 5/16" bit
- 70-8** 3/8" bit
- 75-8** 7/16" bit

#### Straight Bit for Half Pitch Dovetails

Carbide tipped, 8mm shank, for half pitch through dovetail pins

- 140-8** 5/16" bit

#### Half-Blind Dovetail Bits

Carbide tipped, for half-blind dovetails

- 112-500** 12° 1/2" bit
- 128-500** 18° 1/2" bit

#### Straight Bits for Box Joints

High speed steel, for box joints

- 163** 3/32" bit
- 166** 3/16" bit (spiral upcut)

#### Collet Reducer

For 8mm shank bits

- 172-8** 1/2" to 8mm, 1-1/4" long

#### Guide Bushing

For half pitch through dovetail pins

- e7** Leigh elliptical eBush



## Router Table Requirements

Router tables are typically used with a bearing or fence, however, the Leigh RTJ400 is guided around a guide bushing mounted in the router table. Leigh eBushes (guide bushings) are designed around the decades-old Porter Cable/Black & Decker industry standard. Therefore, you will need an insert ring to fit the eBush to your router table or router plate. See specifications below. ■

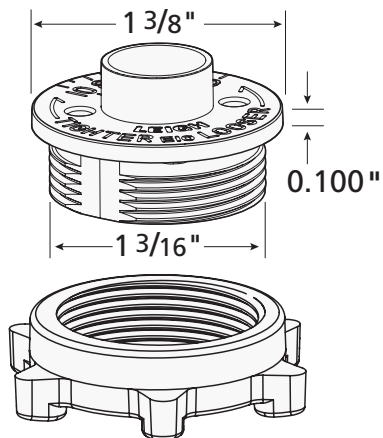

**Leigh eBush and Nut**

To fit the eBush to your router table insert plate, you need a 1-3/8" diameter counter bore insert ring. Check with your router table or insert plate (router lift) manufacturer, as to what adaptation, if any, is required.

