

RTJ400 OPERATION

CHAPTER 5

Wood Preparation

Watch the Online Instructional Video

The online video will reduce your learning time dramatically! Stream to your smart phone or tablet to use in your shop as a visual reference. Find the video in the Instructional Videos section of the Support menu.



Garbage In — Garbage Out

This adage of the computer age stands equally true for dovetail joinery.

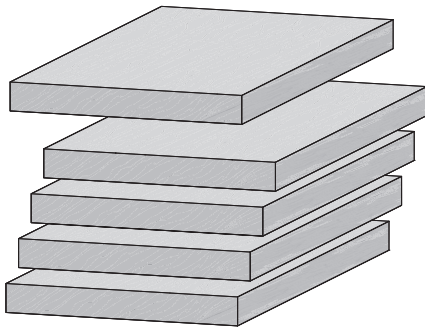

5-1 Accurate and perfectly aligned joints require stock that is straight, flat, even thickness and equal widths, with square ends and edges. **Note: Plywood is generally unsuitable for routing because of tearout problems.**

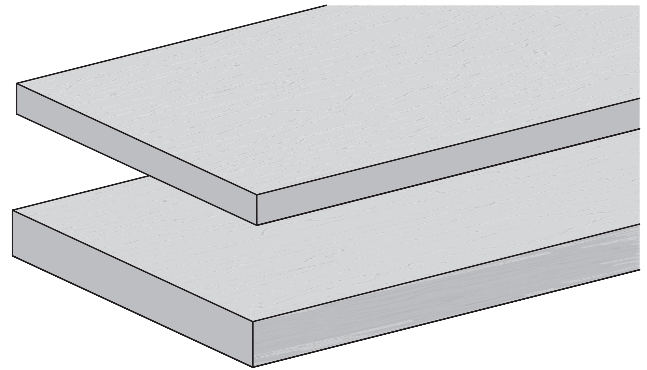

5-2 You will want to test the jig, so prepare boards of suitable size for the required joint type and size. Use them for practice with the jig's various joint modes so you can see how the different modes work. **Note: Two boards of different thicknesses can be joined as easily as one thickness.**

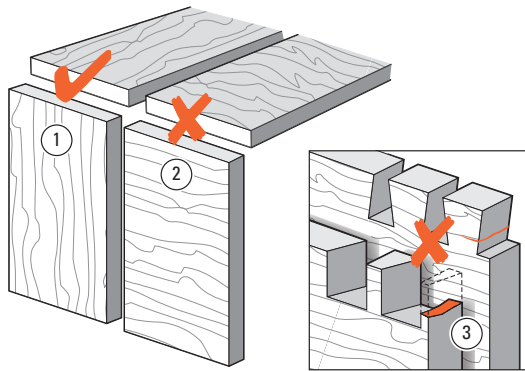

5-3 ⚠ **Dovetail joints are intended for joining end-grain to end-grain** ①. Dovetails in side-grain ② do not work because the wood will tear out badly when routing and the pins and tails would easily break off ③, either during or soon after the assembly when the boards start expanding or contracting at different rates. ■

