

RTJ400 OPERATION

CHAPTER 4

Basic Jig Functions

Router Table Surface

Template Markings and Orientation

Frame Pin Positioning

Quick Reference Strips

Routing Position

Side stops

Clamping

Backer Board

IMPORTANT NOTE: Many of the images in this user guide show the “action” side of the jig, however the operator stands behind the RTJ400, away from the chips and sawdust thrown off by the router bit.

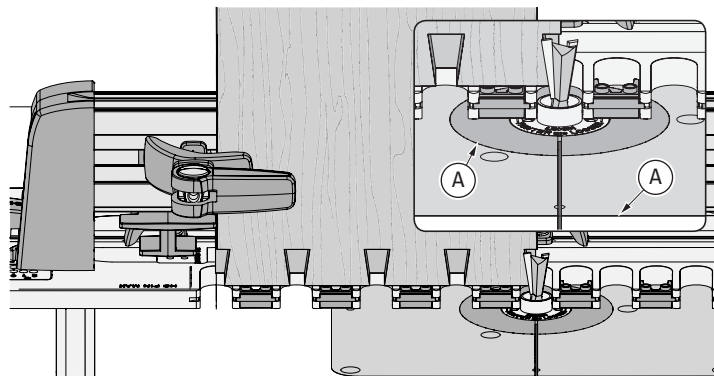

Router Table Surface

4-1 Make sure there are no ridges (A) anywhere on the router table surface. The template must slide smoothly over the table top. If the router table is not flat it will have the effect of changing the bit height as the template moves across the table.

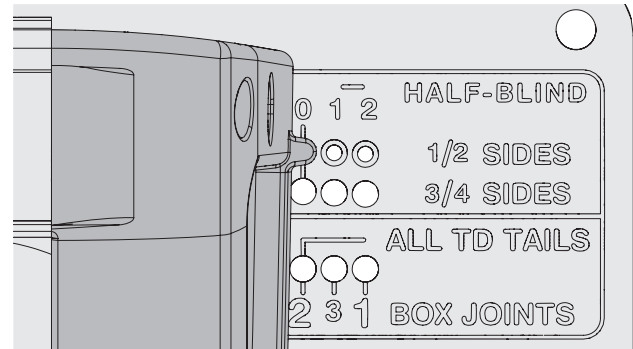

Template Markings and Orientation

4-2 The engraved side of the template always faces up. The markings clearly identify which pin hole or slot to position the frame pin into, based on the joint type and size. Joint type determines the orientation of the template, as outlined below.

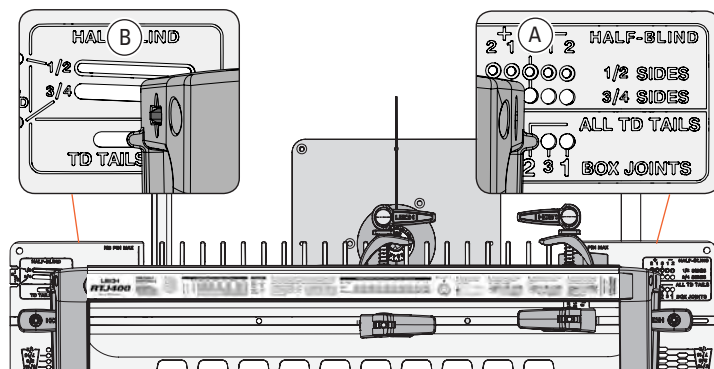

4-3 The template must be used perpendicular to the line drawn on the table. In this orientation, pin holes (A) and corresponding slots (B) are for half-blind dovetails, through tails and box joints.

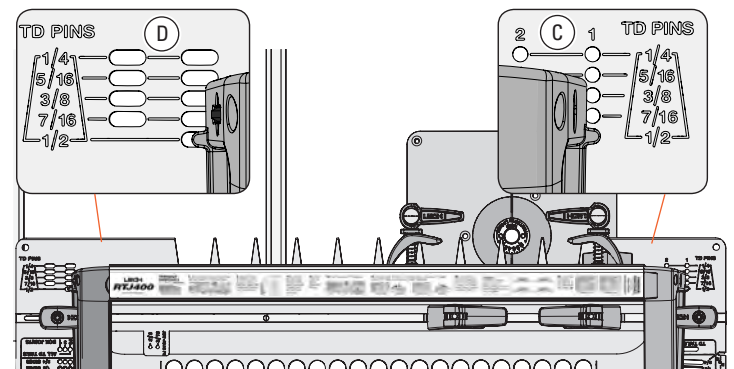

4-4 In this orientation, pin holes (C) and corresponding slots (D) are for through dovetail pins and half pitch through dovetail pins.

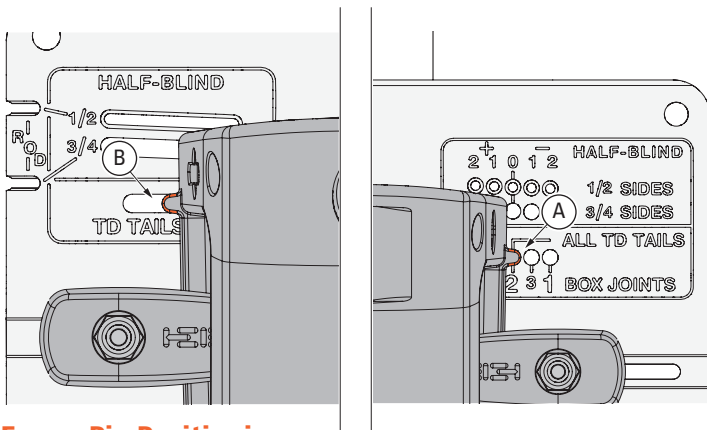

Frame Pin Positioning

4-5 The frame is positioned on the template by inserting the frame pins into the pin holes (A) and slots (B). The frame pins are intended to be snug in the template holes. **⚠ To prevent damage to the frame pin always remove the right frame pin first.**

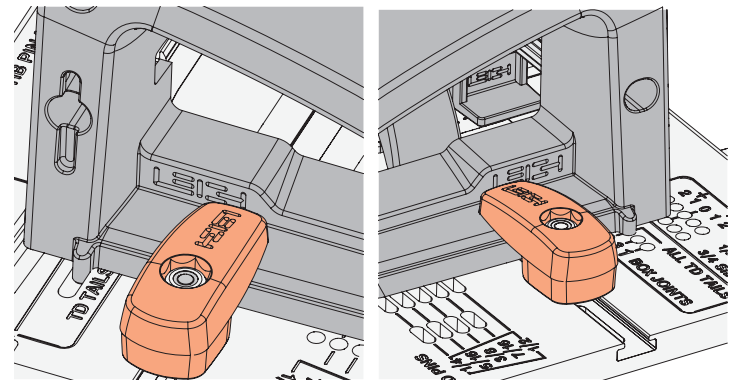

4-6 **⚠ Be sure to latch the frame securely each time the frame is repositioned.** Only when the frame is latched securely is it safe to lift and or carry the jig by the handles.

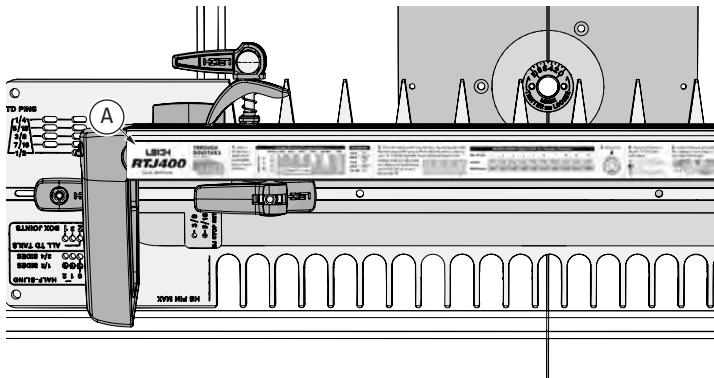

Quick Reference Strips

4-7 Quick Reference strips (A) for each joint type are stored in the slot on the top of the jig frame.

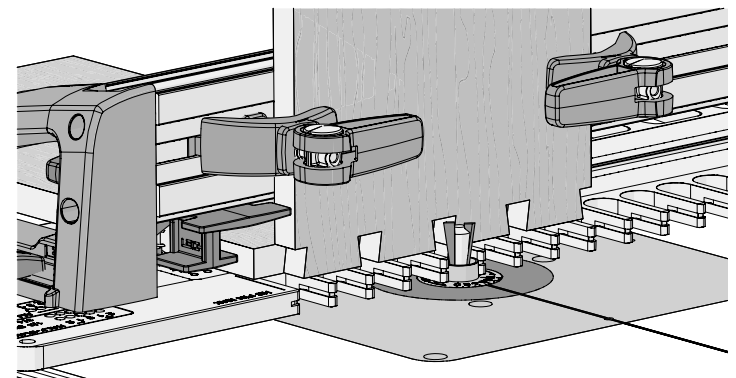

Routing Position

4-8 Always use the right-hand side of the jig as shown above, except where specified. **Note: When instructed to rout from right to left, this is from the "operator's" position, standing behind the RTJ400.**

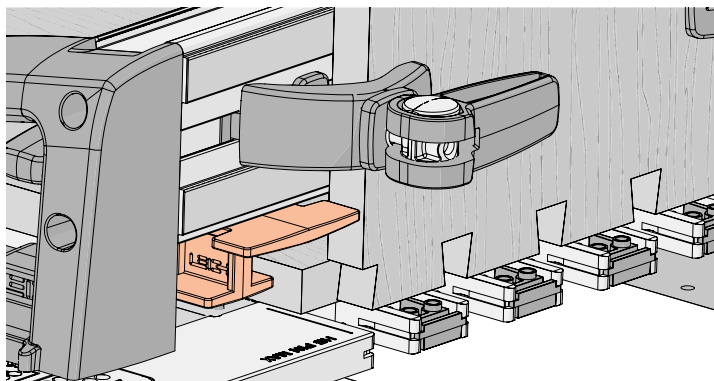

Side stops

4-9 The adjustable side stops are user set in a predetermined position for box joints, or positioned against the edge of the workpiece.

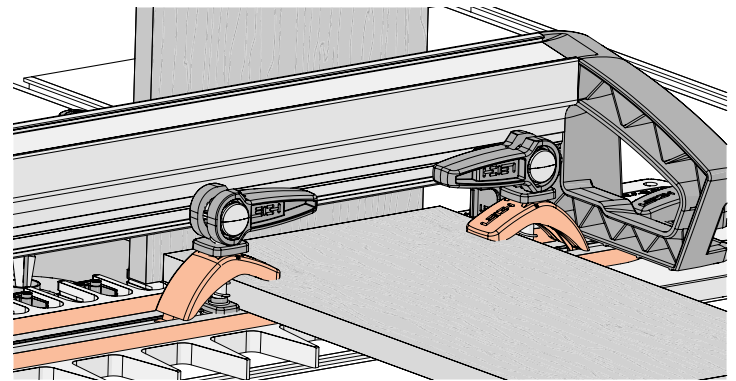

Clamping

4-10 Cam-action speed-clamps are exceptionally strong. The clamp arms in conjunction with the machined texturing on the template and frame ensure secure clamping.

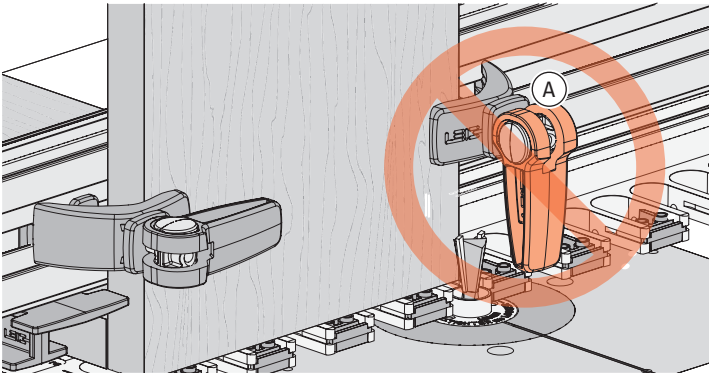

4-11 ⚠️ *Always ensure that the frame clamp levers do not project below the frame when engaged (A).*

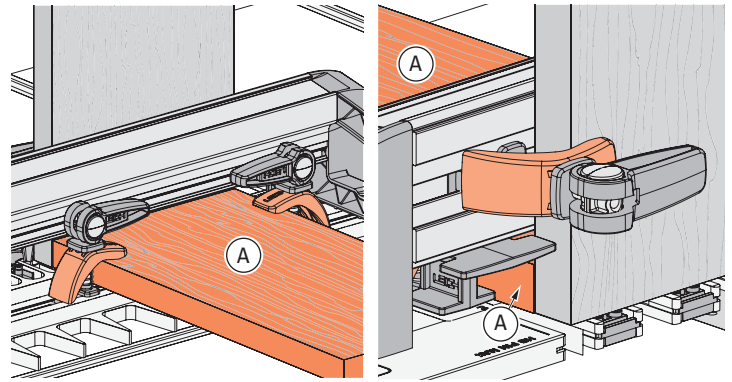

Backer Board

4-12 A short backer board (A) is clamped horizontally behind the tail board, to help prevent tearout, and to direct dust and chips away when routing. ■

