

## RTJ400 OPERATION











## CHAPTER 2

## Glossary of Symbols

**Which Way Around Should the Board Go?**

The following symbols/icons are used throughout this user guide. They indicate which side of a board faces out when clamped in the jig, and which edge goes against the side stop. They also indicate which faces are in or out when assembled. Dashed line symbols indicate the other side of the board (hidden from view).

**Note:** Before you place the boards in the jig, you must mark them with the appropriate symbols.

-  "Outside" of board
-  "Inside" of board
-  "Either side" of board
-  "Outside" of board (on other side of board)
-  "Inside" of board (on other side of board)
-  "Either side" of board (on other side of board)
-  "This edge" against sidestop
-  "This edge" against sidestop
-  "This edge" against sidestop (on other side of board)
-  "This edge" against sidestop (on other side of board)

**Watch the Online Instructional Video**

**The online video will reduce your learning time dramatically!** Stream to your smart phone or tablet to use in your shop as a visual reference. Find the video in the Instructional Videos section of the Support menu.

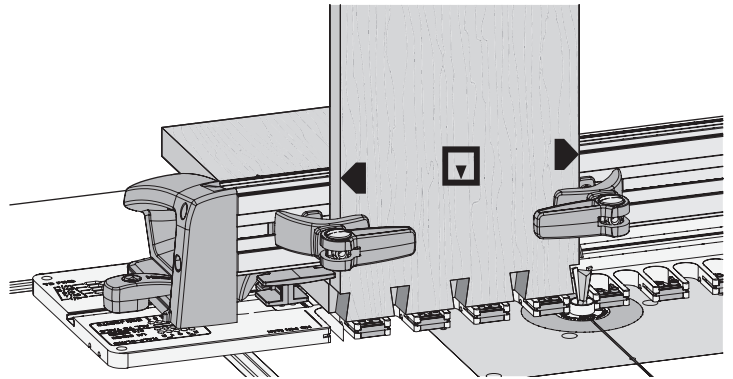

**2-1** Icons such as the one used on the board above indicate which side of the board faces away from the operator when clamped in jig, and which faces are in or out when assembled.

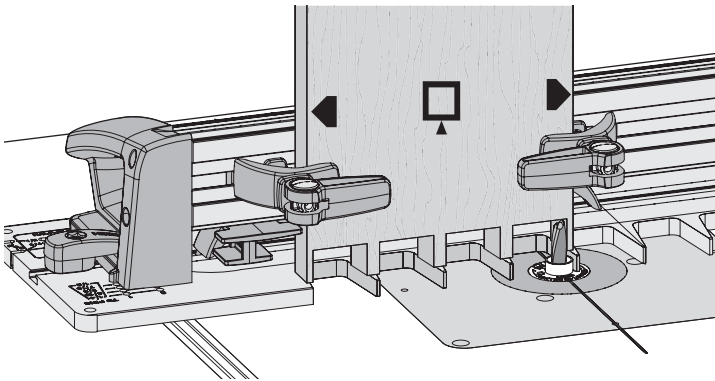

**2-2 Note:** Because through dovetail pin and tail boards are rotated and clamped with the same face against the frame, both side edges are alternately used against the side stop.

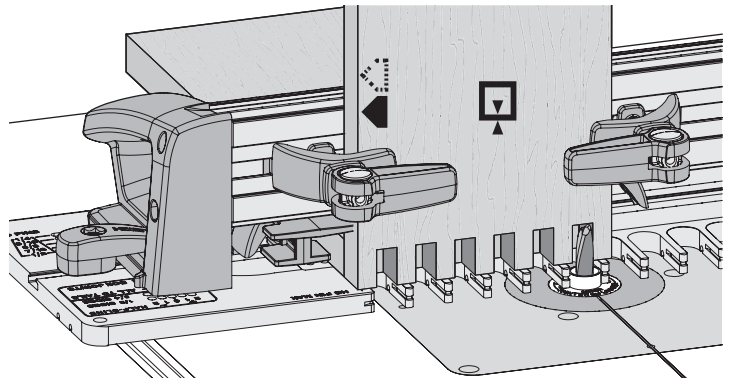

**2-3** Box joint boards are clamped against the frame both face in and face out for alternate end cuts. With box joints, the same side edge always goes against the side stop. ■

