

RTJ400 OPERATION**CHAPTER 1**
Assembling the RTJ400

The following instructions will guide you through the assembly process for the Leigh RTJ400 Router Table Dovetail Jig.

Watch the Online Instructional Video

The online video will reduce your learning time dramatically! Stream to your smart phone or tablet to use in your shop as a visual reference. Find the video in the Instructional Videos section of the Support menu.

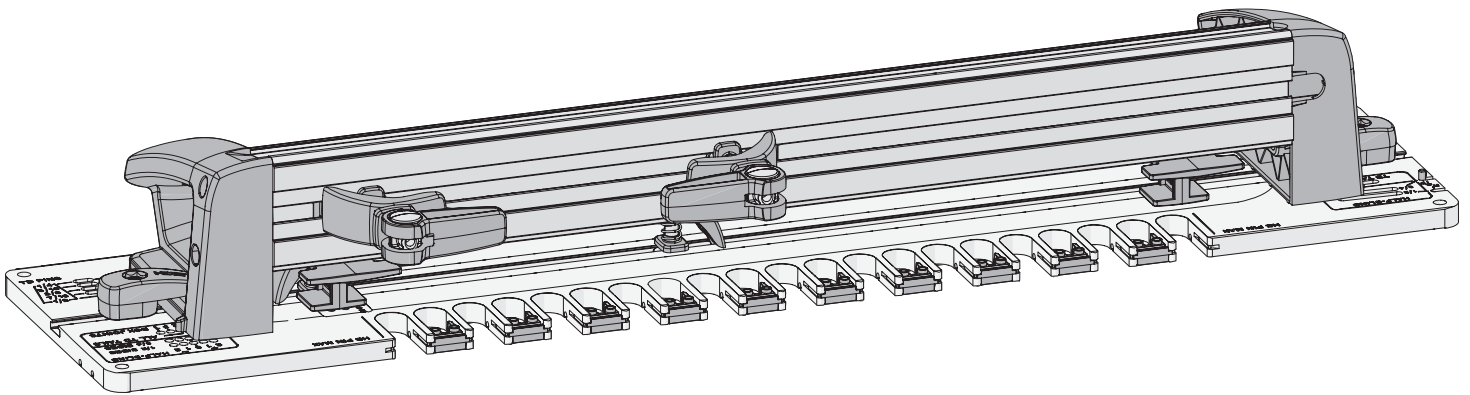
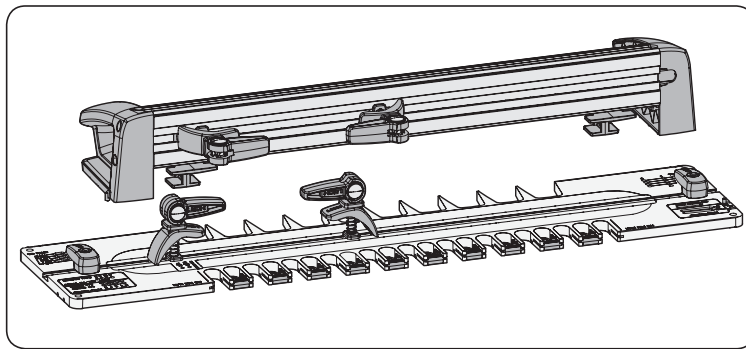

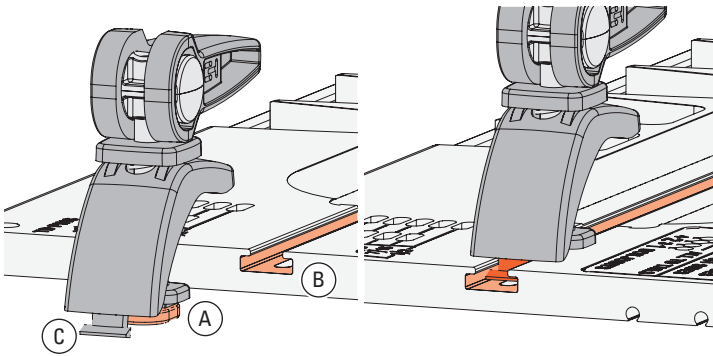

1-1 Template Clamps: Insert the clamp T-bolt head (A) into the T-slot at each end of the template (B) followed by the clamp heel (C). Make sure the heels are pointing out at both ends of the template.

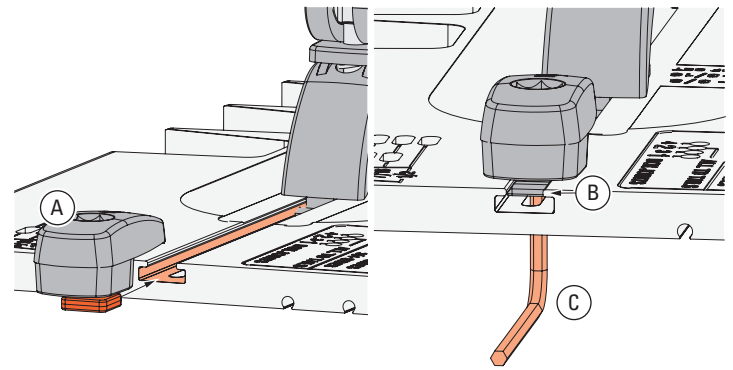

1-2 Template Latches: Slide a latch (A) into each end of the template making sure the washer (B) is in the T-slot. Use the hex key (C) through the slot on the bottom of the template to firmly tighten the latches, pulling the hex nuts down into each latch recess. Adjust the latches so they are stiff to slide on the template.

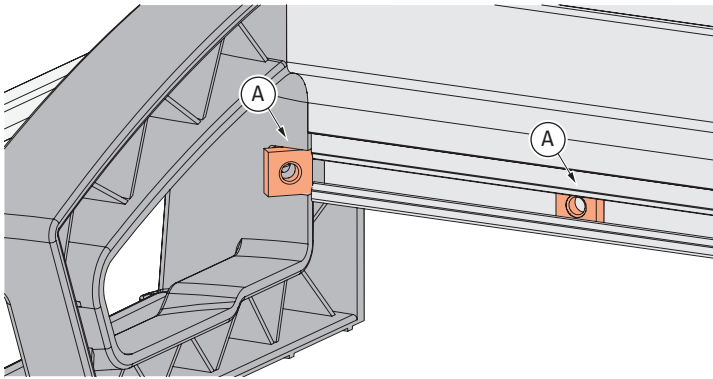

1-3 Insert the two square nuts into the rear of the frame (A) and slide them to each end of the frame.

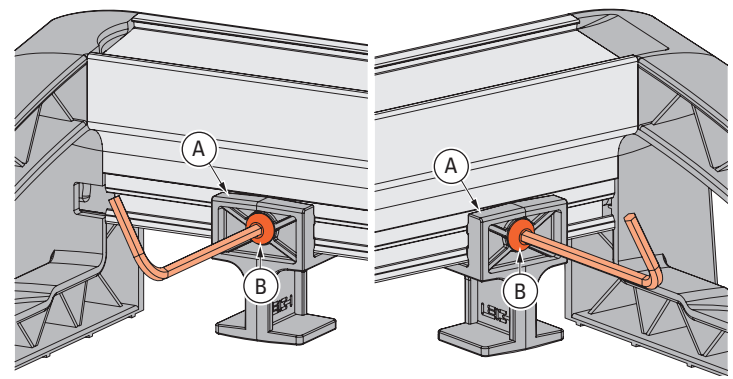

1-4 Side stops: Attach the two side stops (A) to the square nuts in the frame using the hex socket button head screws (B), and lightly tighten one side stop at each end of the frame.

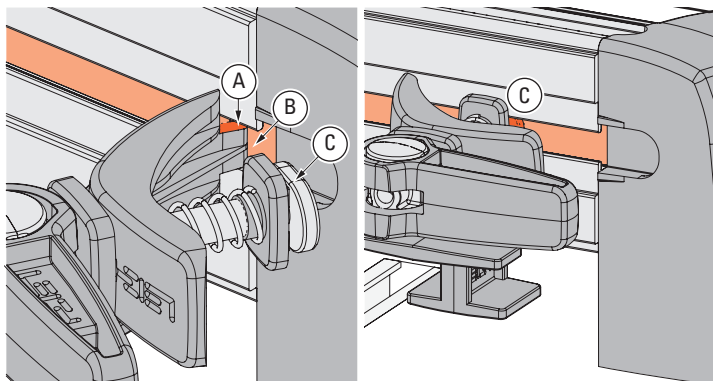

1-5 Frame Clamps: Insert the heel (A) of a pre-assembled clamp assembly into the end of the frame T-slot (B) followed by the clamp T-bolt (C), and slide the clamp to the other end of the frame. **Note: The clamp arm spring washers are under tension. They may need to be pulled away from the T-bolt to aid in ease of assembly.**

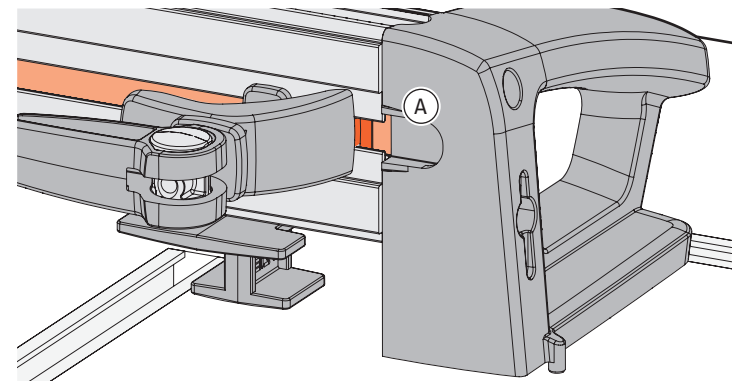

1-6 When installing the second clamp, insert the T-bolt first and the heel last (A).

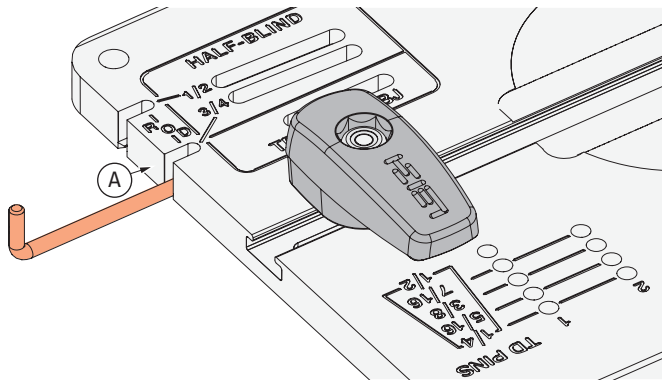

1-7 Stop Rod: Insert the stop rod in the $\frac{3}{4}$ " slot (A). The stop rod remains here for all routing operations except half-blind dovetails and box joints. Note: The stop rod may have been shipped in this location.

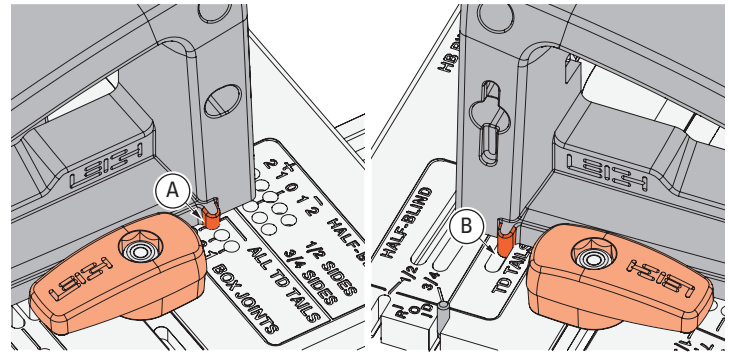

1-8 The frame is located on the template by a pin on the frame handles. Place the frame on the template by inserting the right frame pin in the **ALL TD TAILS** hole (A) and the left frame pin in the **TD TAILS & BJ** slot (B). **⚠ To prevent damage to the frame pin always remove the right frame pin first when lifting the frame handle.**

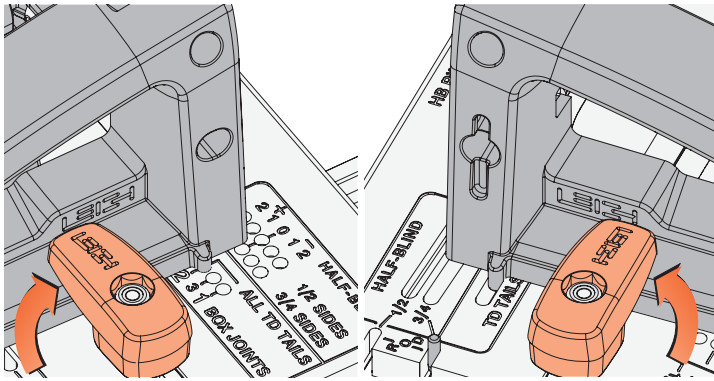

1-9 Pivot both latches to secure the frame to the template. Double check the latches to ensure they are fully seated. **⚠ Only when the frame is latched securely is it safe to lift and or carry the jig by the handles.**

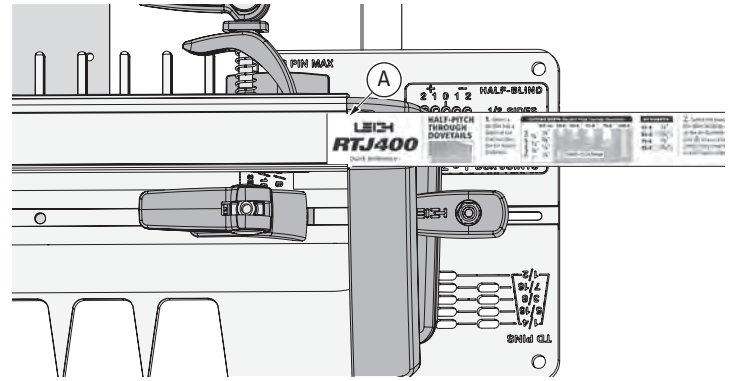

1-10 If not already in channel, slide the Quick Reference strips into the channel in the top of the jig (A).

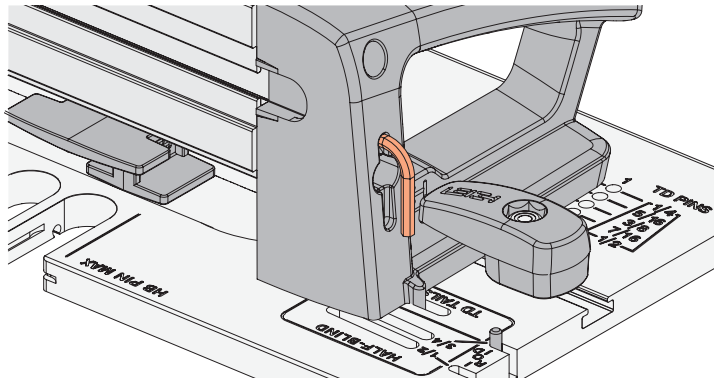

1-11 Store the hex key in the left hand handle.

Leftover parts:

- bit depth gauge
- ten blockers
- e10 guide bushing & nut
- pin wrench
- this user guide

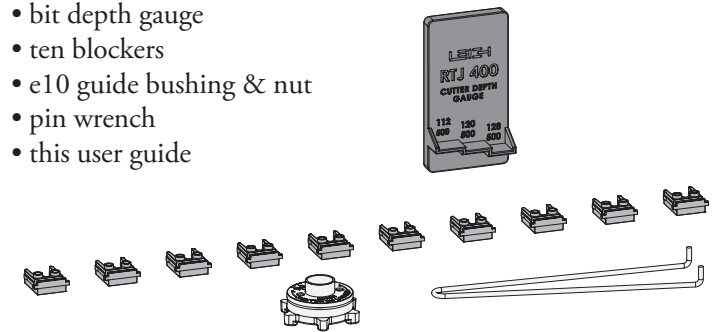

1-12 You will have leftover parts. Keep them to use as required for various jig operations. ■

