

Watch the Online Instructional Video

The online video will reduce your learning time dramatically! Stream to your smart phone or tablet to use in your shop as a visual reference. Find the video in the Instructional Videos section of the Support menu at leighjigs.com.



D4R Pro - CHAPTER 16 Sliding Dovetails

⚠️ Routing sliding dovetail "slots" across the face grain of horizontal boards is very tough on dovetail bits. **Always use the largest shank size available to you;** we recommend at least 8mm shanks, but 1/2" would be even better, with of course the appropriate guidebush.

If you have to use 1/4" shanks in hardwood, use a second router to rough out the slot center with a straight bit.

While we recommend 5/8" [15,9mm] as the ideal size guidebush for sliding dovetails, we appreciate that many users will have only a 7/16" bushing. These instructions cover both those guidebushes. **The Leigh 7/16" e7 and 5/8" e10 guide bushes can be used to make fine fit adjustments for sliding dovetails.**

1

With the Finger Assembly in **HALF-BLIND DOVETAIL TAILS (HB TAILS) mode**, install the sliding dovetail fence (cross-cut fence)

Sliding Dovetail Slots are cut across the board face.

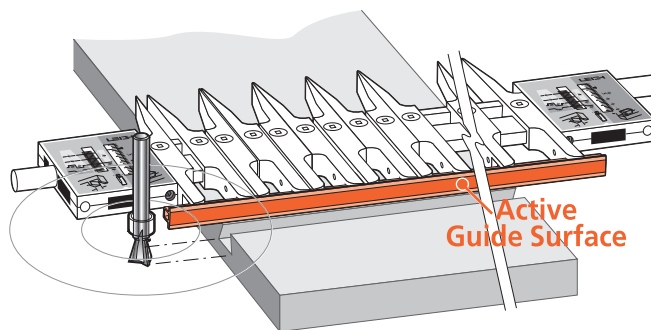
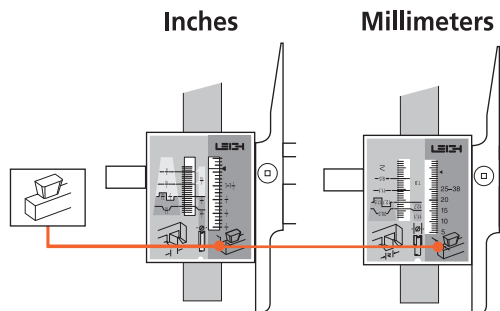

2

KEEP the finger assembly in the same mode

3

Sliding Dovetail Tails are cut across the board end edge

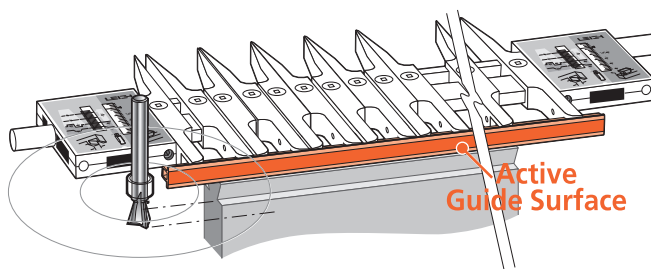
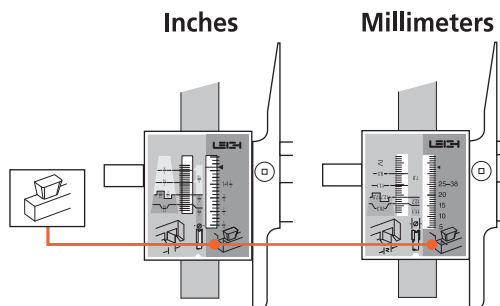

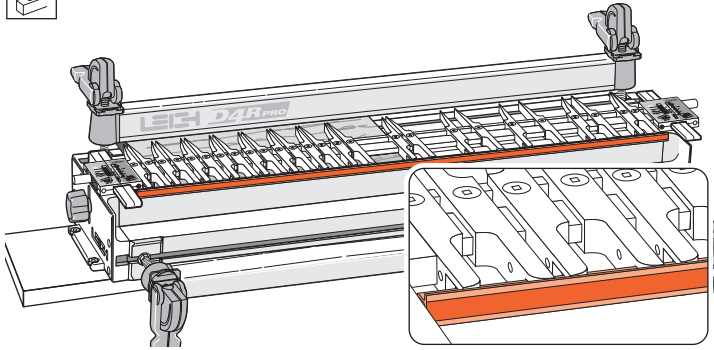

16-1 With the finger assembly in HB TAILS mode, the sliding dovetail fence fits into the recesses in the ends of the tail guides for routing sliding dovetails.

Space the guides fairly evenly across the jig. Firmly seat the fence into end of each guidefinger to ensure a straight cut.

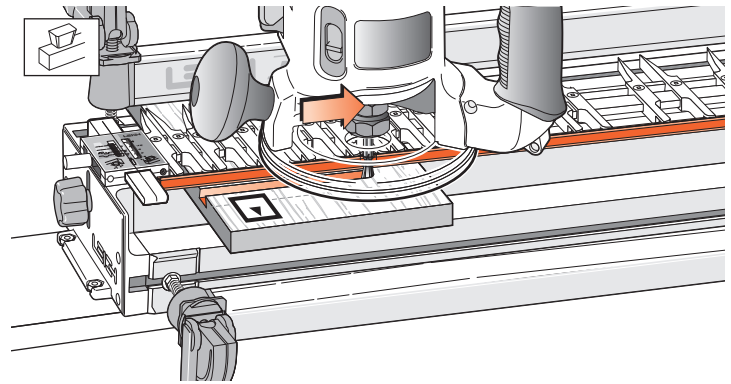

16-2 Using the sliding dovetail fence as a guide surface for the guidebush, you can make lateral router cuts across the faces of horizontal boards (we call these dovetail *slots*), and...

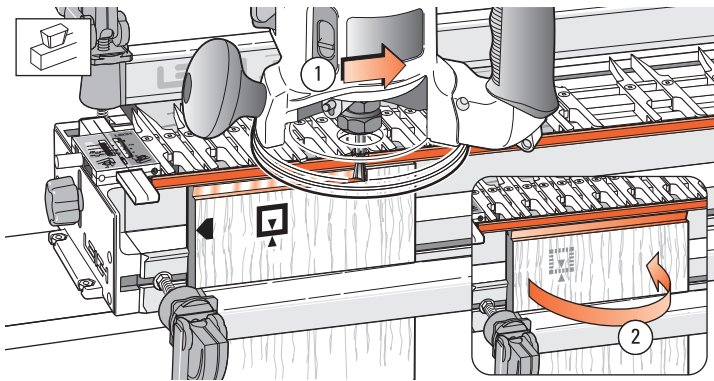

16-3 Across the top ends of vertical boards to cut the tail. First rout one side ①...

...then turn the board side-over-side ② to cut the other half of the tail.

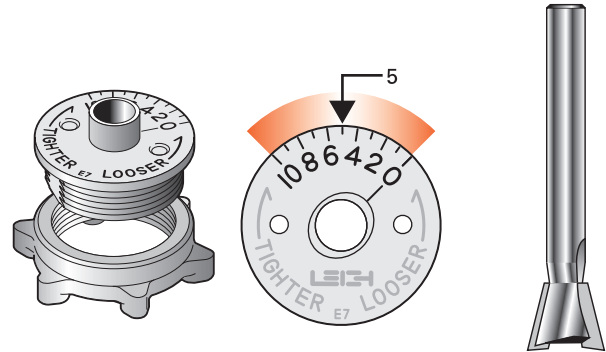

16-4 Turn the e7-Bush to “5” and use the No. 120-8, 1/2" x 14° bit for sliding dovetails. This e7-Bush setting will allow for fine fit adjustment of the tail later.

A standard 7/16" [11,1mm] guidebush (min. depth 1/4" [6,35mm] see page 69) can be used but without the fine adjustment provided by the e7-Bush.

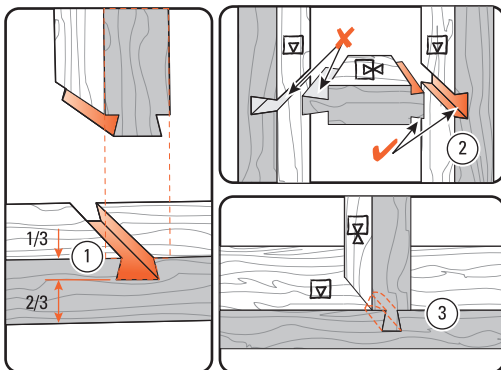

16-5 On a full width joint, the slot depth-of-cut should be no more than 1/3 the board thickness ①. If the tail board is a load-bearing horizontal member (e.g., bookshelf or step), make the tail fairly thick for good tail neck strength ②. Shorter sliding dovetails for less structural demand may be slightly deeper, with narrower profiles, especially if appearance is important ③ (e.g., where narrow rails join wider boards).

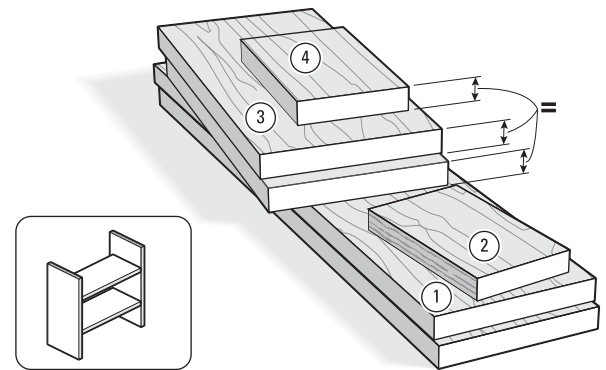

16-6 Use 3/4" x 5 1/2" [20x140mm] softwood to make two slot boards ①, plus one narrow test slot board ②, two tail boards ③ and one narrow test tail board ④. The tail boards ③ and test tail board ④ must be exactly the same thickness. This will make two uprights and two shelves.

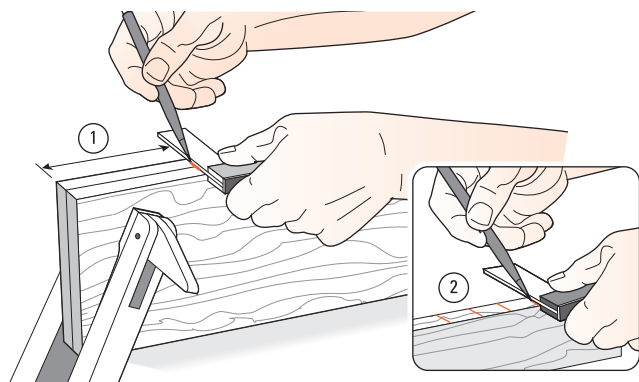

16-7 Marking Out: Do not mark slot positions on board faces; mark the edges ① of both slot boards together for perfectly level shelves. Mark the narrow test slot board in the same way at several closely spaced random spots ②. This board is used only for setup.

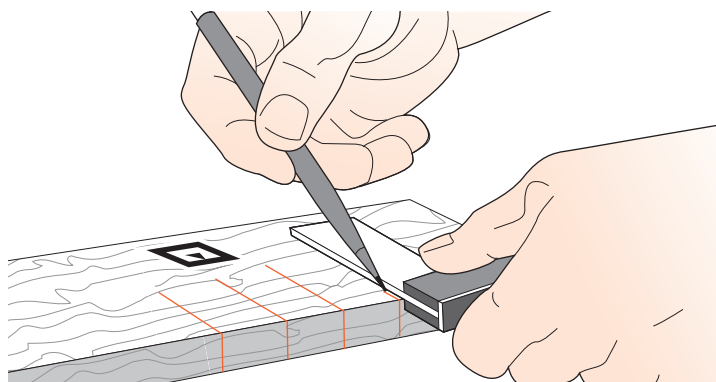

16-8 On the test slot board only, square the marks across the face.

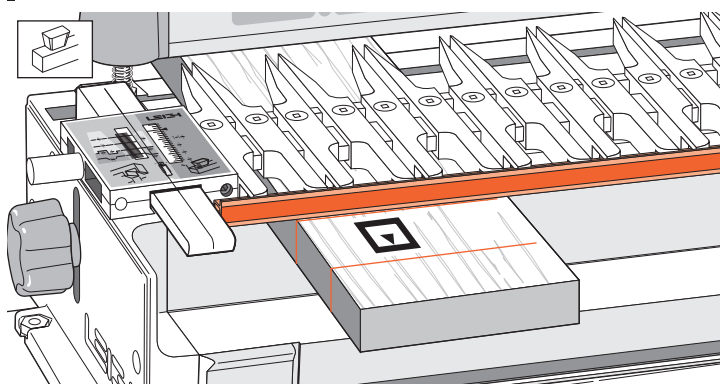

16-9 Mount the test slot board in the rear clamp, markings up. **⚠** Dovetail slots are best routed from left to right because the bit's clockwise rotation pulls the guidebush against the fence. But when routing close to both ends of a board, you may need to route slots from right to left. See 16-30.

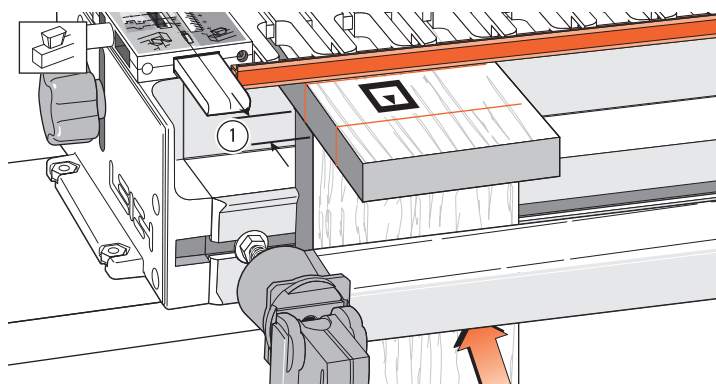

16-10 Mount a 3/4" [20mm] thick ① (yes, the 3/4" [20mm] thickness is important) square-ended board vertically in the front clamp against the side stop, with the top edge butting the underside of the test board.

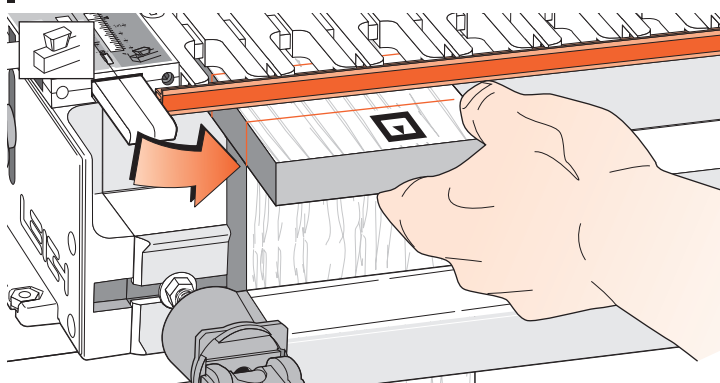

16-11 Position and clamp the test board so that one of the edge marks is in line with the outside edge of the vertical board.

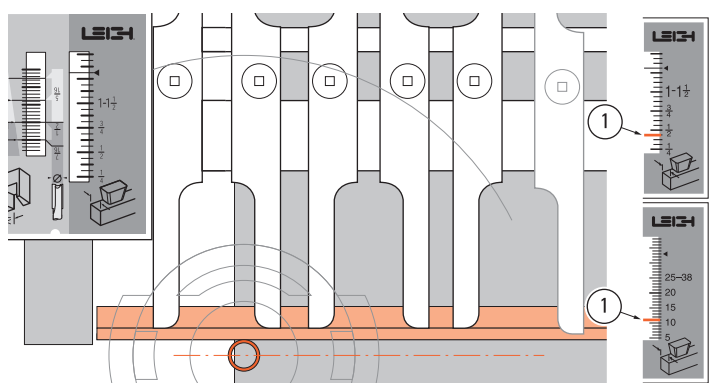

16-12 With the finger assembly (including the sliding dovetail fence) on the support brackets in the HB TAILS mode, set the scale to 7/16" [11mm] ①. Make sure the finger assembly is level and sitting flush on top of the board. The HB TAILS scale was not designed for this operation, but with this setting the routed slot will be close to centered on the slot line.

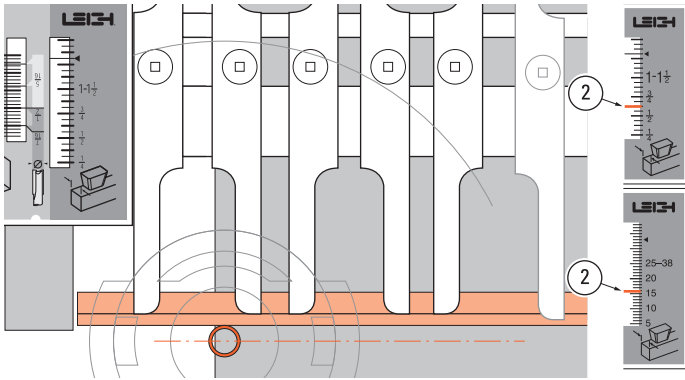

16-13 If you use a larger guidebush, for example $\frac{5}{8}$ " [15,9mm] rather than $\frac{7}{16}$ " [11,1mm], move the scale in by the difference of the two guidebush radii.
E.g., suggested scale reading for a $\frac{5}{8}$ " [15,9mm] guidebush would be $1\frac{1}{32}$ " [9mm] ②.

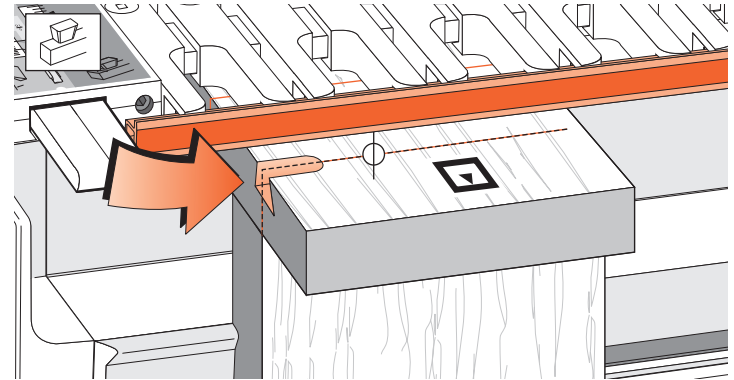

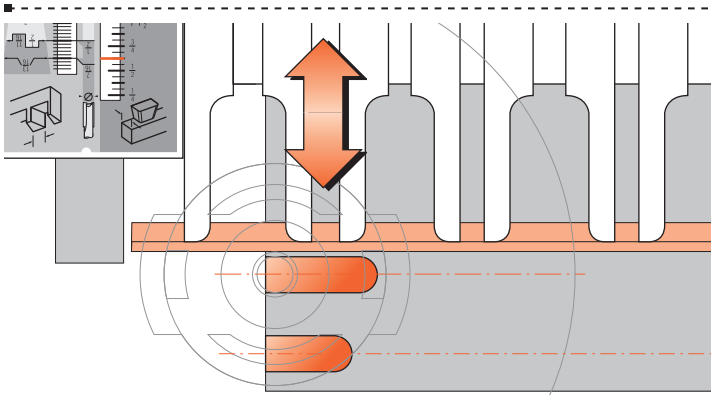

16-14 Adjust the bit so the cut depth is about $\frac{5}{16}$ " [8mm]. Rout from left to right maintaining light inward pressure of the guidebush on the fence. Rout in only about 1" [25mm] and back out again.

 **Do not lift the router.**

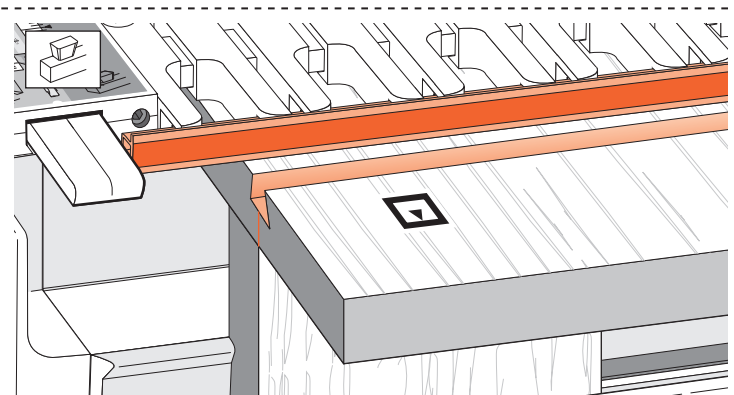

16-15 Check to see if this short slot is centered on the pencil line. If not, adjust the finger assembly in or out and retest on the other lines as necessary until the slot is centered. Lock the finger assembly in this position and record the setting for future reference.



16-16 Now rout sliding dovetail slots in the two main slot boards with the boards in the horizontal position in the rear clamp, slot side, that is inside face  up.
The guidefingers must be flush on the board.

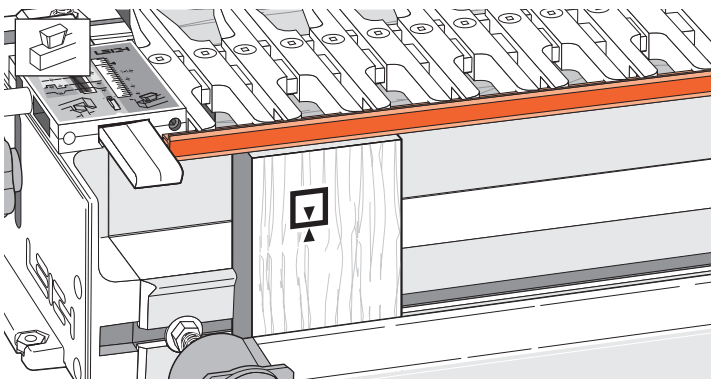

16-17 Replace the spacer board in the rear clamp, and with the finger assembly on the spacer board, mount a test tail board vertically in the front clamp, **flush under the guidefingers**. Either side can face out .

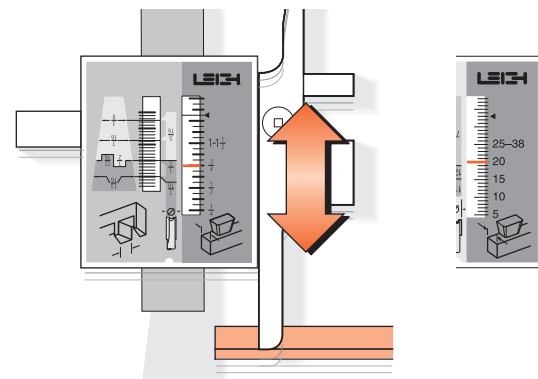

16-18 The  HB TAILS scale is not designed specifically for this mode, but it does allow you to make precise adjustments for tail size and tightness of fit on sliding dovetails.

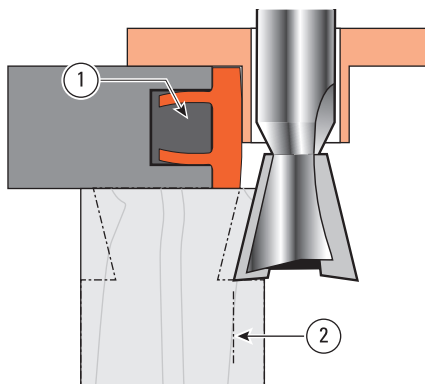

16-19 Adjust and set the finger assembly ① so it is clear that the routed tail ② will be too large for the slot.

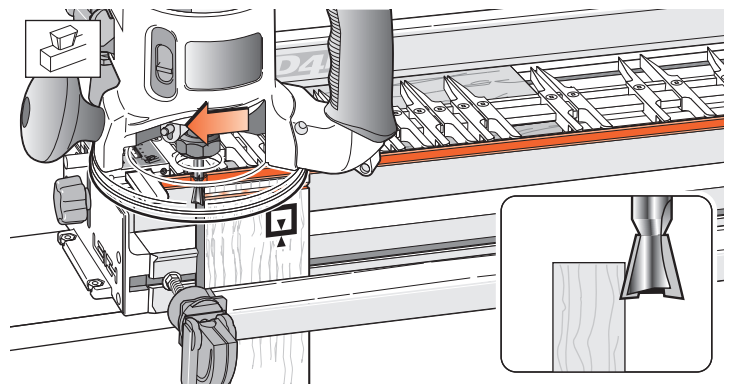

16-20 ⚠️ Rout one side of the test tail board. Make one light pass from right to left (climb routing). Make sure you control it firmly, because it is driven in this direction by the bit. Only the tip of the bit should be cutting on the first cut (see inset). This *back* or *climb* routing leaves a very clean shoulder in side grain.

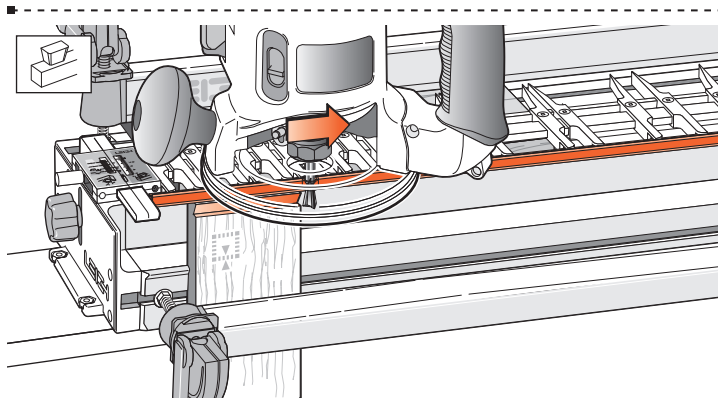

16-21 Finish left to right, with the guidebush touching the fence.

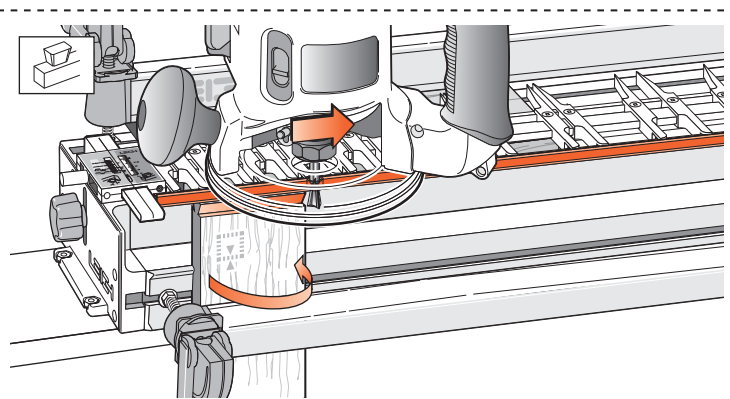

16-22 Turn the test tail board around in the jig and rout the other side as above.

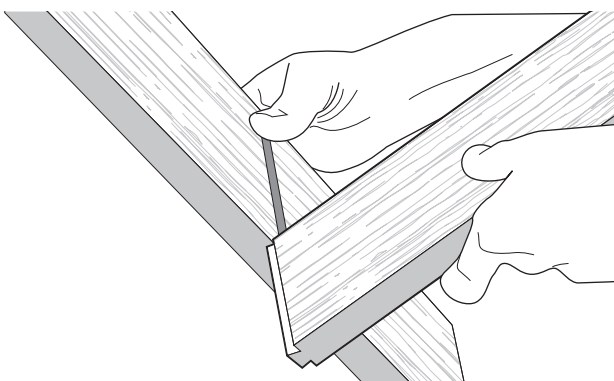

16-23 Test the joint for fit. The tail should be too big. If it is too small, adjust the finger assembly outward by at least half the difference and rout another test tail on the other end of this test board.

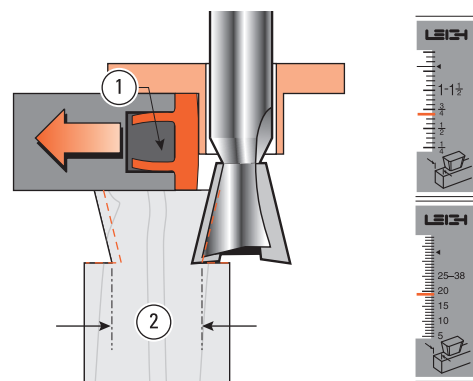

16-24 If the tail ② is too big, move the finger assembly ① toward the jig by half the amount the tail is too big. Rout the same test board again; keep adjusting and testing until a good fit. *Use trial and error each time. It doesn't take long, and you get a good fit. For fine fit adjustment with the e-Bush see 16-25.*

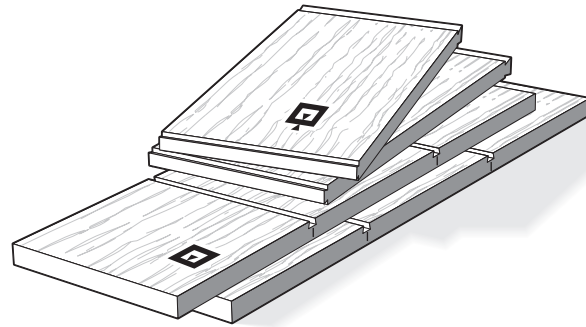
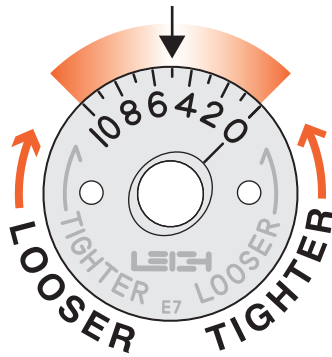

16-25 Note: the e7-Bush fit adjustment for sliding dovetails works reverse to normal. Fit adjustments are made by adjusting the tail size only, not the socket. The e7-Bush is turned down to a lower number for a tighter fit, and up to a higher number for a looser fit. Each increment changes the glue line fit by 0.001”[0,025mm] When the fit is satisfactory, rout one end of a project tail board and test again. If the fit is good, rout all tail board ends.

16-26 When the fit is satisfactory, rout one end of a project tail board and test again. If the fit is good, rout all the other ends. *Note: Variations in board thickness, guidebush diameter, bit depth, angle, diameter and concentricity, make it impractical to record sliding tail size settings.*

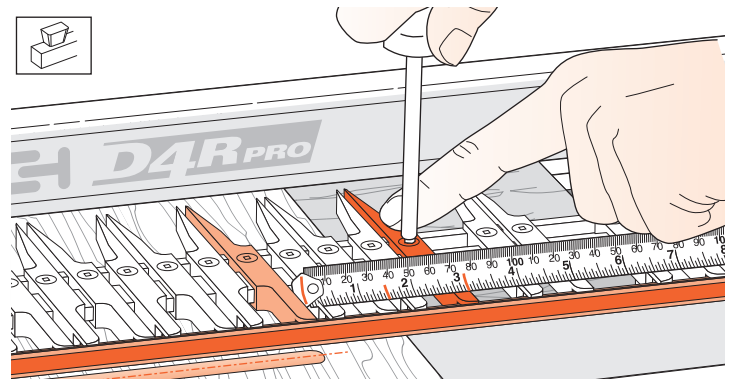
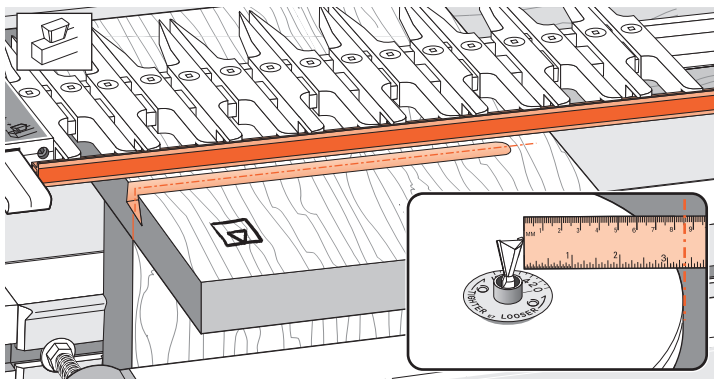

16-27 Stopped Sliding Dovetails
If a stopped sliding dovetail is called for...

Measure from the outside tip of the dovetail bit to the edge of the router base.

16-28 Measure the same distance from where you want the slot stopped to a position on the finger assembly. Move a guidefinger to that point and mark the guidefinger with a felt pen as a visual router stop mark...

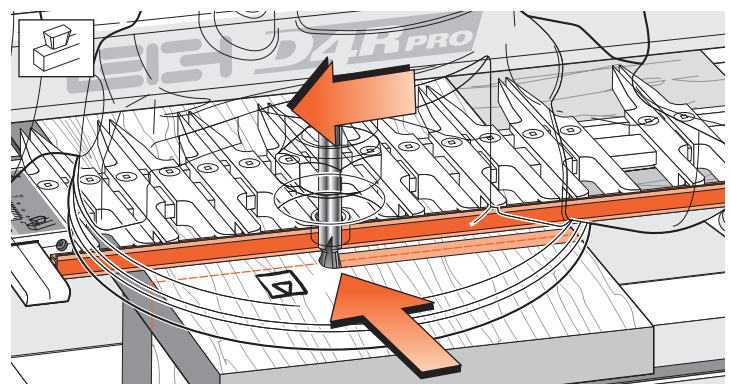
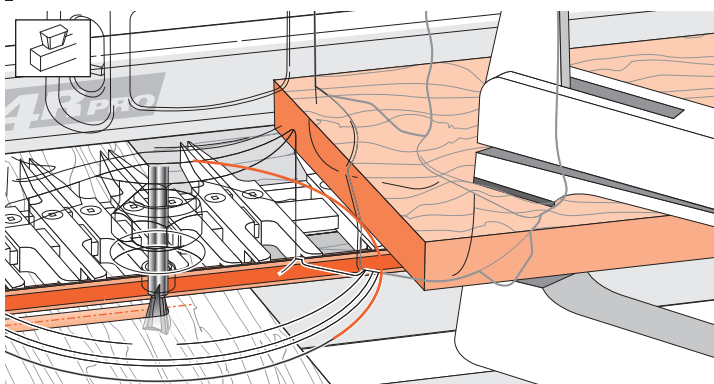

16-29 Or lightly clamp (with a soft-jawed clamp) a short board to the finger assembly to act as a router stop.

16-30 ⚠️ Dovetail slots preferably are routed from left to right because the bit’s clockwise rotation pulls the guidebush against the fence. However; as when routing close to both ends of a board, it may be necessary to rout slots from right to left. Bit rotation will tend to pull the router away from the fence. Feed slower and maintain constant guidebush pressure against the fence. ■