

DA! USER GUIDE

Leigh Dovetail Jig

LEIGH
Joining Tradition with Today

Your New Leigh Dovetail Jig

Congratulations! You now own the world's most useful and versatile joinery tool. The Leigh Dovetail Jig will help you cut an infinite variety of joints, and all of its major functions are described in detail in this manual. A very helpful video is also included, but the manual is essential reading.

We recommend that you first assemble and mount the jig, carefully following the instructions in the first section of the manual. Then read the rest of the manual, following along with the basic functions and principles of operation, before you try to do any actual joinery routing. By all means, cut a few practice joints in scrap boards before you use the jig to

route a precious hardwood workpiece! If you have any questions that are not answered in the manual, please call the Leigh customer support line*.

But remember: "If at first you don't succeed, read the instructions!"

*See Appendix IV – Customer Support

Important! Inches and Millimetres

Leigh makes the D4 jig in two models; inch or metric. Text and illustrations in this Leigh English-language user guide indicate dimensions in both inches and millimetres. Dimensions are indicated in text and illustrations with "inches" first, followed by "millimetres" in square brackets.

Example: $\frac{3}{4}$ " x $5\frac{1}{2}$ " x 8" [20 x 140 x 200mm]

Do not be concerned if the inch/millimetre equivalents are not always exact. Just use the dimensions which apply to your jig.

Where finger assembly scales overlay an illustration, the "inches" scale ① will be at the top, the "millimetres" scale ② will be at the bottom. Only the right hand "active" half of the scales are illustrated. For clarity, setting positions are indicated with a red line in the manual only. **On the jig, the lines are black.**

To simplify the instructions, some jig illustrations show a jig considerably shorter than the standard 24" [610mm].

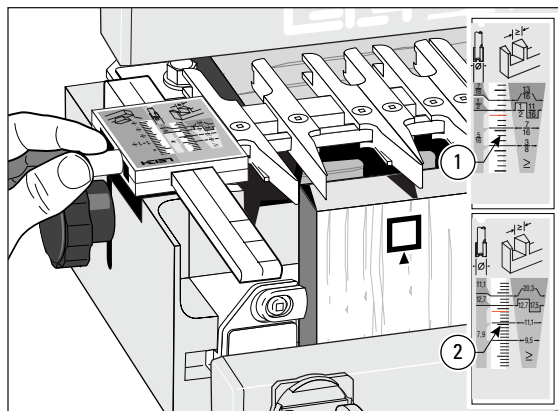

Glossary of Symbols	iv
Chapter 1 – Jig Assembly, Mounting and Using the Clamps	1
Chapter 2 – Adjusting the Finger Assembly	15
Chapter 3 – How Routers with Guidebushes Work	21
Chapter 4 – Operation Concepts and Basic Jig Functions	25
Chapter 5 – Using Your Jig Safely	35
Chapter 6 – Wood Preparation	43
Chapter 7 – Router Preparation	47
Chapter 8 – Through Dovetail Procedures.....	51
Chapter 9 – Large and Small Through Dovetails	69
Chapter 10 – Half-Blind Dovetail Procedures.....	75
Chapter 11 – Rabbeted Half-Blind Dovetails	89
Chapter 12 – End-on-End Dovetails	95
Chapter 13 – Asymmetric Dovetails	101
Chapter 14 – Sliding Dovetail Procedures	113
Chapter 15 – Quick Reference – Through Dovetails	131
Chapter 16 – Quick Reference – Half-Blind Dovetails.....	135
Chapter 17 – Hints and Tips	139
Appendix I – Guidebush Selection.....	149
Appendix II – Cutter Selection	155
Appendix III – Jig Parts List.....	163
Appendix IV – Customer Support	167

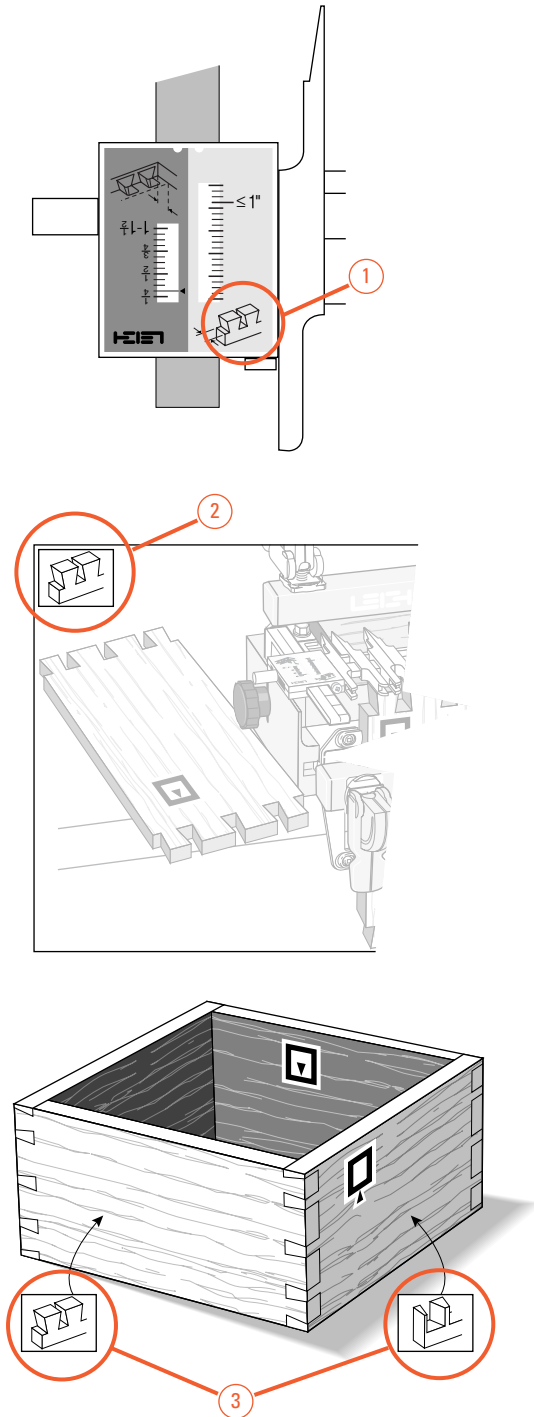

How to Read the Symbols

To help you understand the instructions and illustrations in this manual, we have used a number of international symbols, plus a few special ones of our own. They are all explained below. **You needn't worry about memorizing these symbols now**, because they are repeated quite frequently in the manual, and you will soon get used to them.

Glossary of Symbols

The Leigh jig's guidefinger assembly can be in any one of four joint modes, depending on what type of joint and which part of the joint you are cutting. Each finger assembly scale has its own mode icon^①, identifying that joint part. You will also find the joint mode icon in the top left corner of most illustrations^②, indicating which finger assembly mode to use. Sometimes a joint mode icon will be used to identify a board^③.

These are the four joint mode icons:



TD Tails
(tails for through dovetail joints)



TD Pins
(pins for through dovetail joints)



HB Tails
(tails for half-blind dovetail joints)



HB Pins
(pins for half-blind dovetail joints)

Which Way Round Should the Board Go?

Most joinery done on the Leigh jig is for case-work (i.e., boxes, cabinets, drawers, chests and so on) so in nearly all the illustrations we have indicated **which side of the board shows outwards when it is in the jig**, eg. in this figure the inside face  of the tail board is away from the jig.

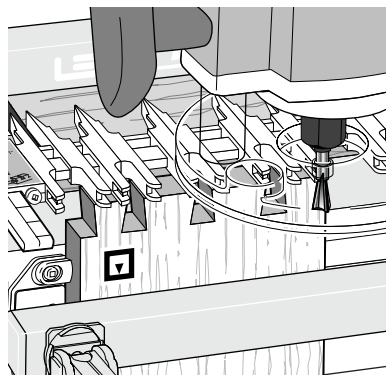

This indicates the side of the board that will face outward on the finished project.



This indicates the side of the board that will face inward on the finished project.



This indicates a side that can face either way on the finished project



Dotted line icons are on the other side of the board.

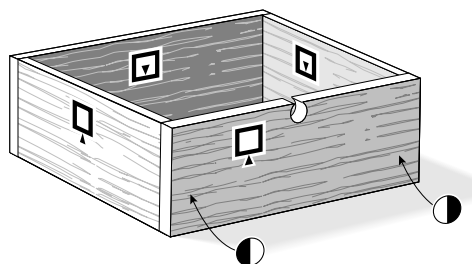

The following symbols indicate:



Left side of item (drawer, box, case, etc.)



Right side of item



Top of item



Bottom of item



This edge against sidestop



This edge against sidestop



Sawcut allowance



Caution: use special care for this operation

①②③ Reference in text

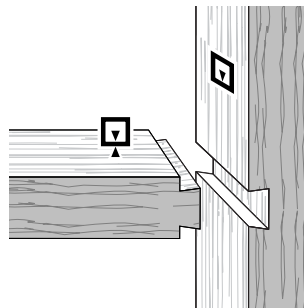

Centreline of board or layout



Equals



Does not equal



Approximately



Less than or equal to



Greater than or equal to

Jig Assembly, Mounting And Using The Clamps

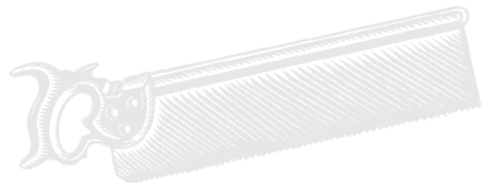
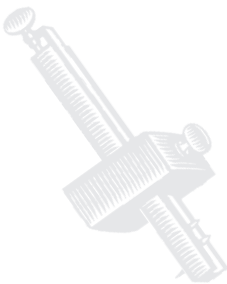
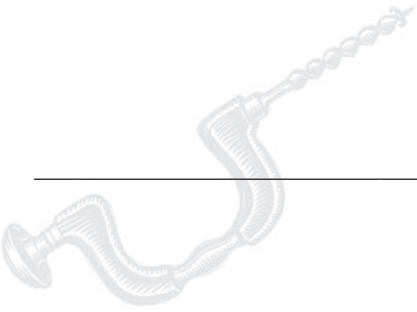

Make Sure You Have All the Parts!

Before you start to assemble your Leigh D4 jig, check to make sure you have received all the required parts.

The small carton you removed from the end of the main carton contains:

1. 1 VHS instructional video (english only)
2 scale assemblies, 2 standard cutters, and any other small optional items you may have ordered with your new jig. Check the packing slip for this information.

The main carton contains:

2. 2 clamp bars
1 main jig body

Inside the main jig body, there should be:

3. 1 cross cut bar
1 finger assembly on two bars
(D4 jig has 26 guidefingers)
4. 4 cam-action speed clamps
4 cam clamp step washers
5. 1 Leigh jig user guide
6. 1 square-head guidefinger screwdriver
7. 2 support brackets
2 knobs
2 nylon washers
8. 4 side stop assemblies
(2 left hand, 2 right hand)
9. 6 T-bolts
4 springs
6 hex nuts
2 cross cut bar end caps
7 flat washers
1 hex bolt
1 flat head machine screw
2 square nuts
1 Leigh wrench/gauge/angle side stop

If any of these items are missing from your jig, please notify your supplier or Leigh Industries immediately.

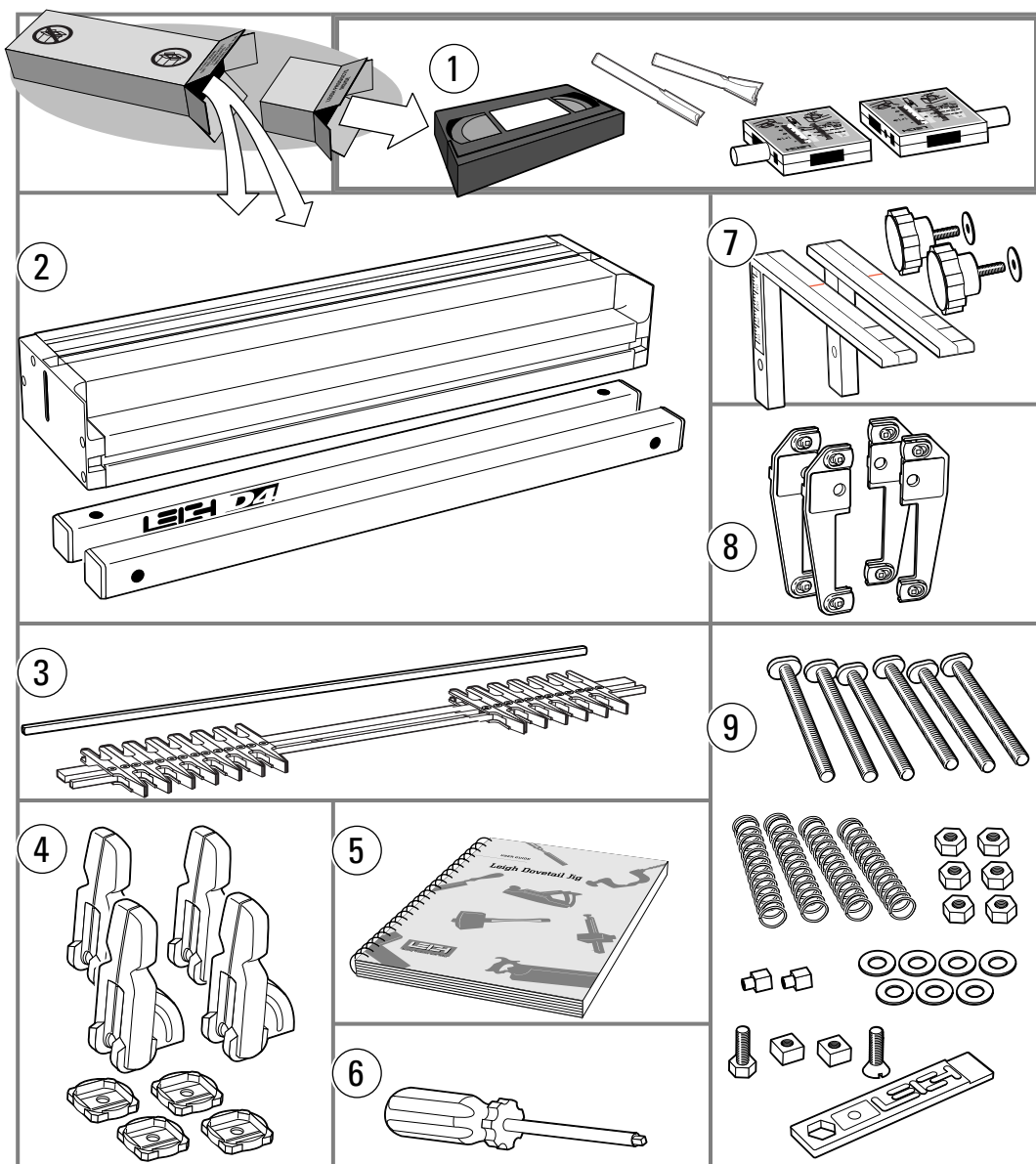

Important Note

Mount your jig securely and assemble it completely before you try to use it.

Make sure you have read and understood all the material in the Safety section of this user guide before using the jig.

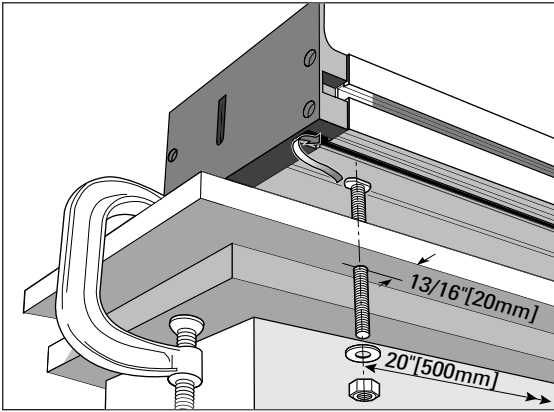
**1-1**

Insert two T-bolts in the slot under the front extrusion. Bolt the jig either directly to a bench or to a base suitable for clamping to a bench, as illustrated, i.e. 1 x 8" [20 x 180 mm] x 36" [915mm] long. Fit the T-bolts at approximately 20" [500mm] centres, $\frac{13}{16}$ " [20mm] in from the edge, and cut them to length as required.

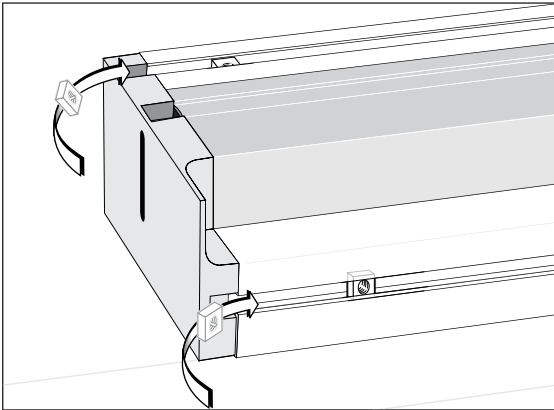
**1-2**

Insert one square nut (part #284) into the channel of the front and top main extrusions. The nuts are for the possible future attachment of accessories.

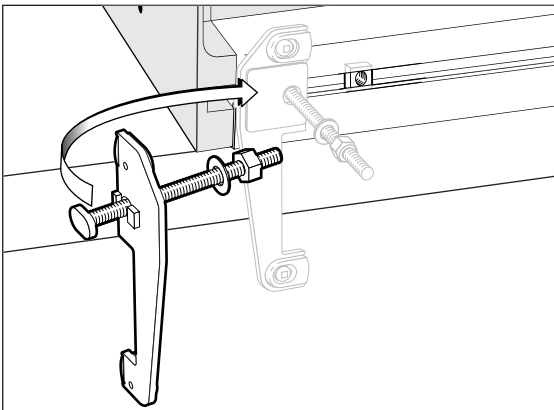
**1-3**

Insert two T-bolt/sidestop sub-assemblies into each of the two main extrusions. Make sure the side stop, washer, and nut are in the correct order as illustrated, with the locating lugs engaging in the extrusion slot.

Note: The lugs will be tight to enter the extrusion slot but the nut will force them in. See 1-4 before tightening.

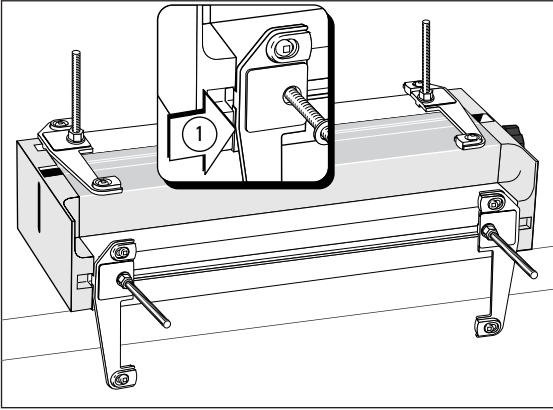
**1-4**

Position the side stops with the outer edge of the casting flush with the ends of the extrusion ①. Firmly tighten the nuts until the side stops are seated.

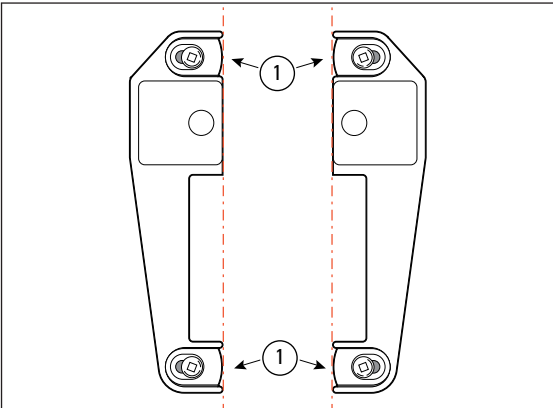
**1-5**

Note that the adjustable bumpers ① are factory set in the retracted position, which is set back from the main body of the side-stop. This is for setup alignment purposes, covered later in this chapter. If yours are not in this position, make sure that they are before proceeding.

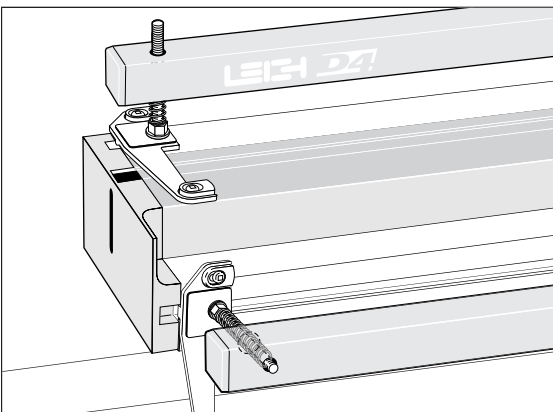
**1-6**

Place four springs and two clamp bars on the T-bolts. The large holes in the clamp bars go right over the springs. Make sure the clamp bars move freely on the T-bolts. The Leigh logo should be on the rear (upper) clamp bar facing you.

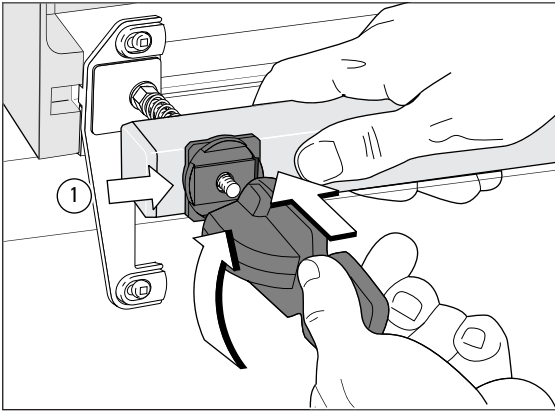
**1-7**

Place one black step washer ① on each T-bolt with the *flat side against the clamp bar*. Screw a clamp lever assembly onto each T-bolt, making sure the cam lobes are between the step washer sidewalls.

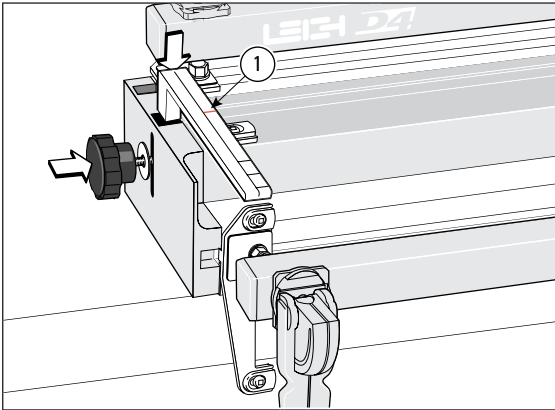
**1-8**

Insert the right and left (marked RH and LH) support brackets. Attach the knobs and nylon washers, raise them to full height and tighten the knobs.

Note: The set line on this support bracket ① is shown in red for clarity in this manual only. The actual bracket lines are black.

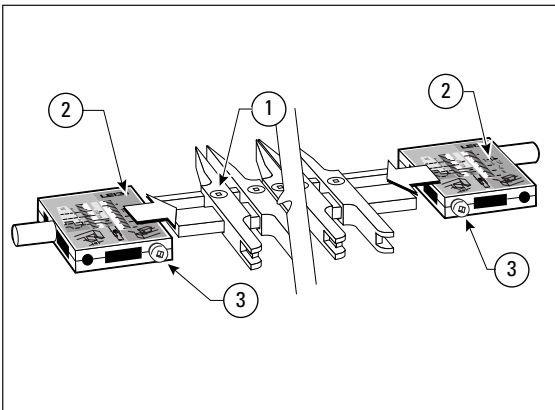
**1-9**

Place the finger assembly on your bench with the guidefinger screws ① on top and the sharp ends of the guidefingers pointing away from you. Fit the scales onto the finger assembly, placing the HB TAILS scale ② to the right at both ends. **Do not tighten the scale screws ③ yet.**

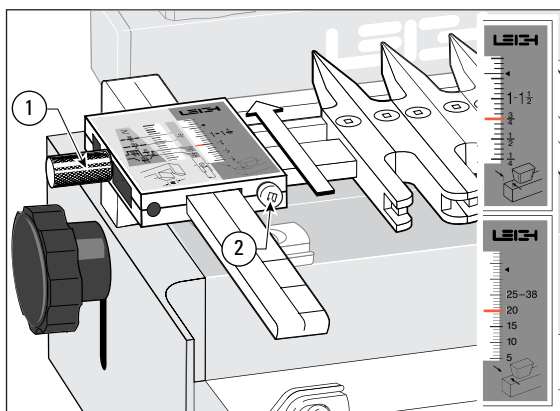

1-10

Slide the complete finger assembly with loose scales onto the support brackets. Set rear bracket line at $\frac{3}{4}$ " [20mm] on the HB TAILS scale and tighten the thumb screws ①. Tighten the scale screws ② with the Leigh screwdriver. **Do not over-tighten.** To ensure correct finger assembly alignment, follow this same procedure whenever you remove the scales from the finger assembly.

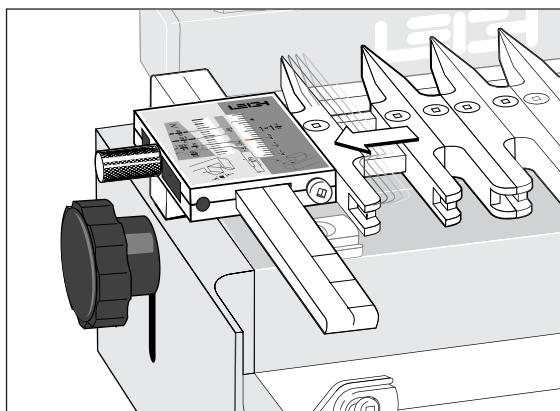

1-11

Move the outermost guidefinger at each end of the finger assembly outward to touch the scales, and lightly tighten. This finger acts as an end support for the router and is not used as a guide.

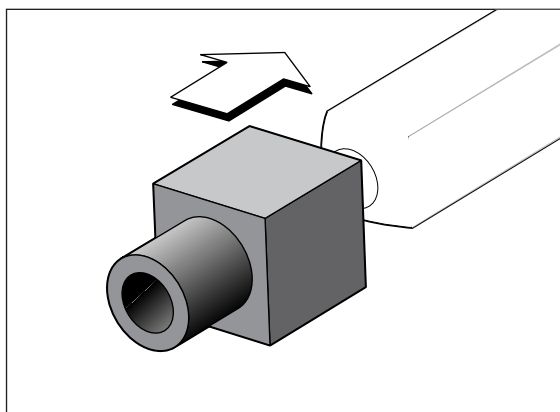

1-12

Press one plastic cap onto each end of the cross-cut bar as shown, and set the bar aside until needed.

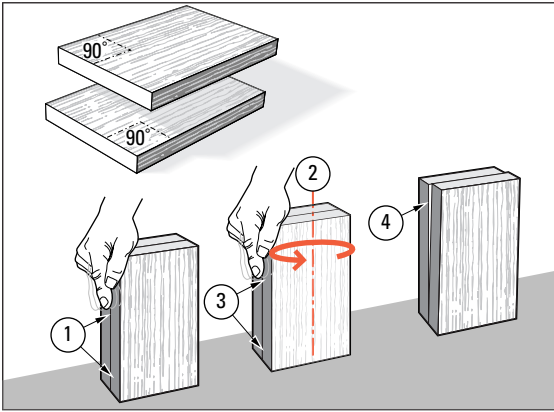
**1-13**

Now you will need two boards $\frac{3}{4}$ "x6" [20x140mm]x8" [200mm] or longer, for practising with the cam-action clamps. **Both pieces need to have square ends for setting the side stops later.**

 Do not trust your square! To check for squareness: stand both pieces vertically on a flat surface, make sure the side edges are flush at the bottom and then at the top ①. Turn one piece around on its end ②. If side edges are flush top to bottom ③, the boards are square. If not ④; cut two that are.

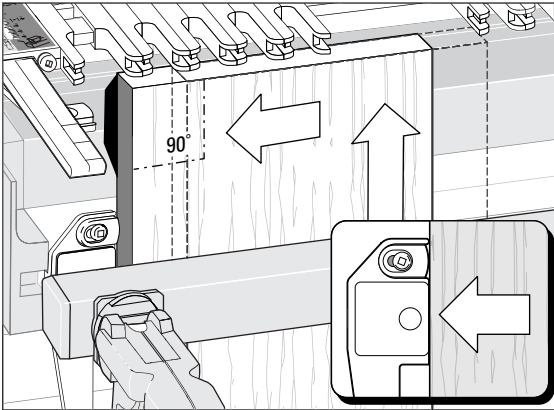
**1-14**

You will operate the cam-action speed-clamps every time you use the jig, so get used to the feel of the clamps first. Use the square ended boards for practice. Make sure the end of the board is touching the underside of the guidefingers. Then slide the board over against the side stop. Do not worry about setting the side stop bumpers until after you are familiar with the clamp operation.

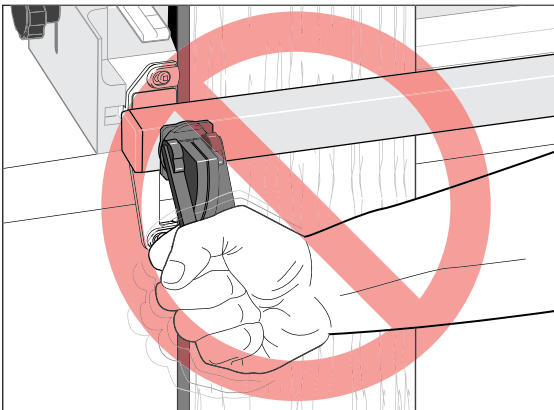
**1-15**

Do Not force the cam-action speed-clamp. It has great leverage, and excessive force may damage the workpiece or the jig.

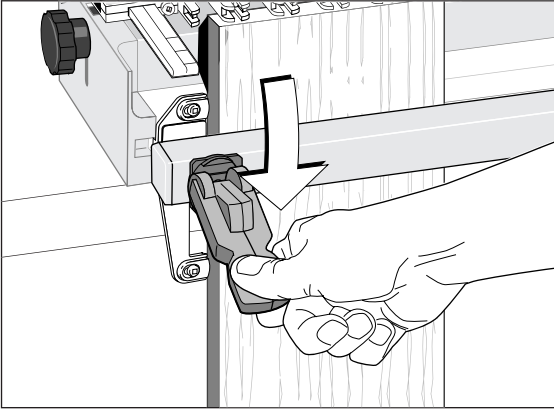
**1-16**

A smooth, firm action is enough to engage the clamp.

Rule of thumb: If you can't throw the lever comfortably by pressing the end of it with your thumb, reduce the tension. A few minutes of trial and error will help you feel the right clamp tension.

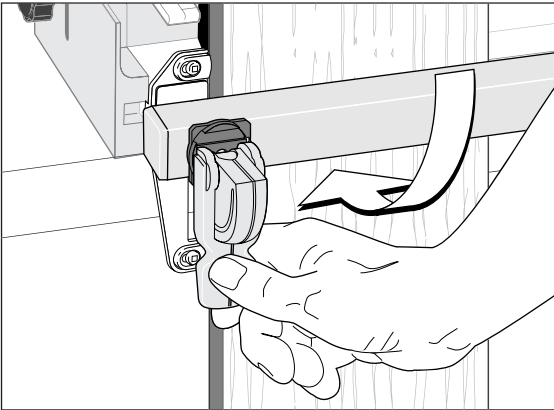
**1-17**

Firm thumb pressure is about right.

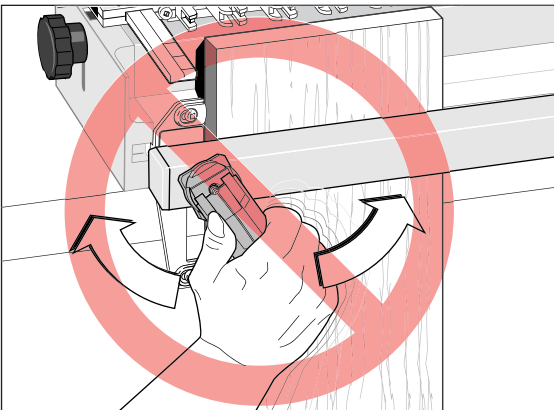
**1-18**

Do Not use the lever as a torque arm.

Adjust the clamp tension only with the clamp disengaged.

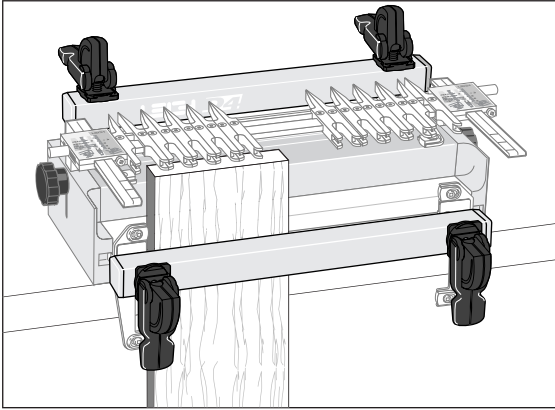
**1-19**

When engaged, the front clamp levers should point down and the rear clamp levers should point away from the operator.

To simplify the instructions, most jig illustrations will show a jig considerably shorter than the standard 24" [610mm] jig.

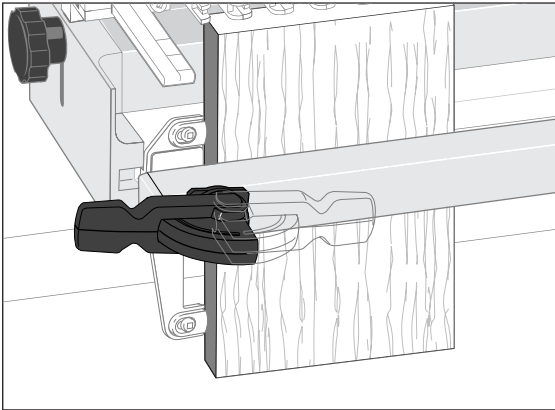
**1-20**

If the lever is badly positioned at the correct clamping pressure...

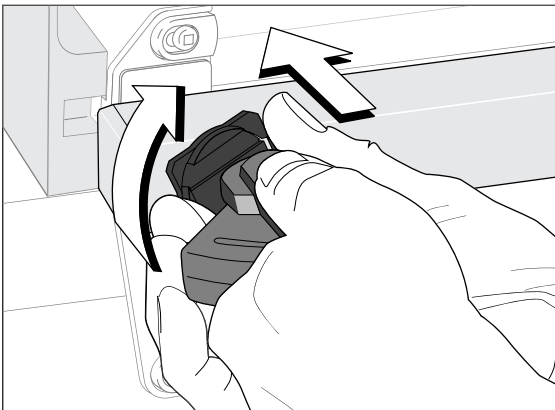
**1-21**

Release the clamp, remove the board and turn the step washer a quarter turn (the step height inside the step washer is one quarter of the thread pitch).

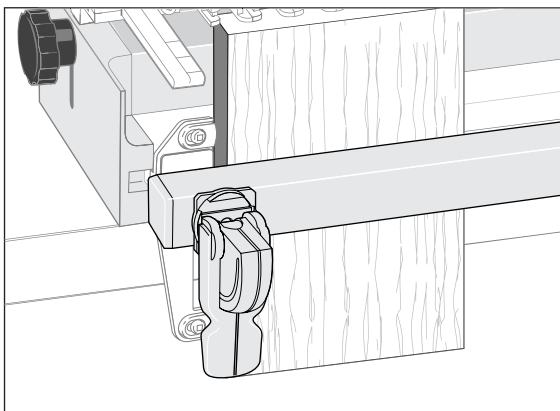
**1-22**

Then adjust the clamp until the clamp lever is in the right position at the right pressure.

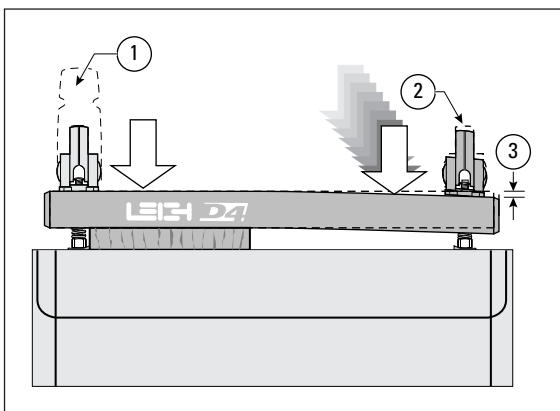
**1-23**

For all but the wider workpieces, you need only operate the clamp on the workpiece end ① of the jig to release the board. For narrower boards, the clamp at the free end ② should be just tight enough to bow the clamp bar about $\frac{1}{8}$ " [3mm] ③.

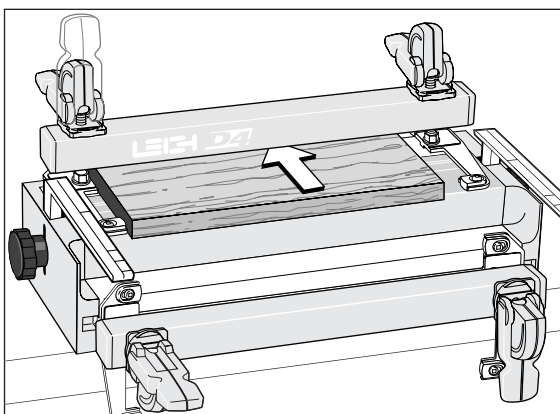
**1-24**

Make up a spacer board. This board will be used to support the finger assembly in all front-clamping vertical board modes. The spacer board should be flat, straight and of even thickness. We suggest $\frac{3}{4}$ " x 6" [20x150mm] by approximately 23" [580mm] long. Note: the thickness of the spacer board has no relationship to the thickness of the vertical board being routed.

Chapter 1 D4 User Guide

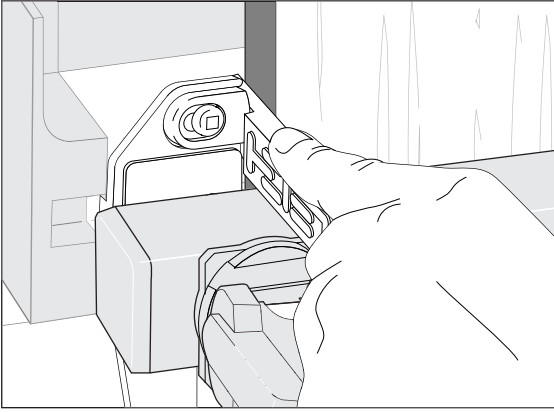

1-25 Place the finger assembly on the support brackets (any mode), resting flat on the spacer board. *Leigh F1 Template owners: the F1 requires a more precise side stop setting. Follow the F1 instructions 1-3 through 1-30, then return to this D4 guide instructions 1-27 through 1-33. Otherwise, begin here with 1-24.* To set the D4 sidestop bumpers, leave the clamps adjusted to receive the two square boards. Use the thin end of the Leigh Wrench to position one of the 90° test boards away from the front left hand side stop casting. Make sure the top end edge of the board is touching flush under the guide fingers.

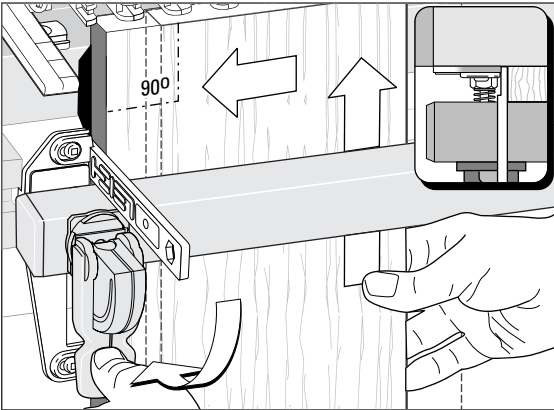

1-26
With the wrench trapped in place, clamp the board.

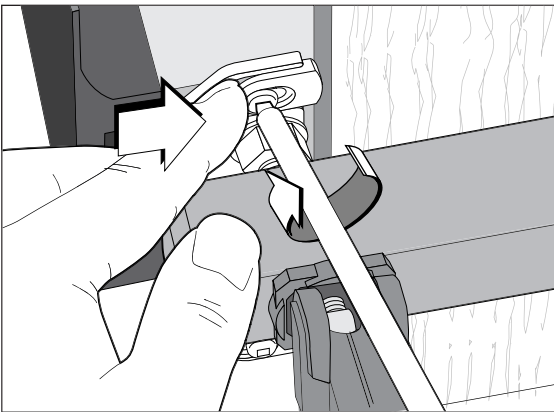

1-27
Remove the wrench and loosen the bumper setscrews. Slide the top bumper against the board and tighten the screw firmly. Position and tighten the bottom bumper. *Leave the board in place.*

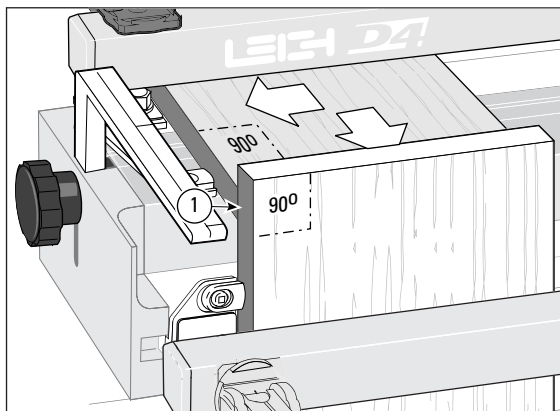
**1-28**

Remove the finger assembly.
Place the second 90° test board under the rear clamp, front end edge flush against the front board. Slide the rear board side to side until the left side edges are flush ①.

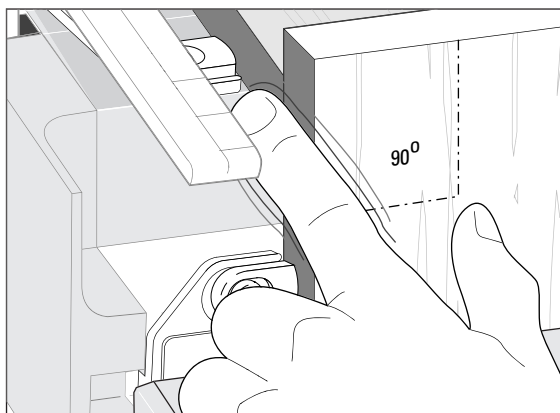
**1-29**

Check with your fingertip to make sure it is flush.

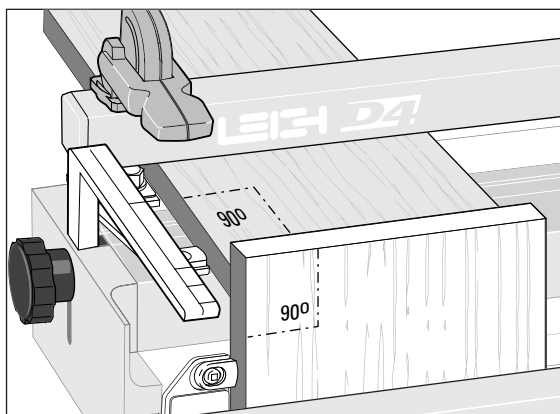
**1-30**

Clamp the rear board by pulling the lever forward (this one time only so that the rear bumper screw is accessible). Position the bumpers against the top board and tighten the setscrews.
The left hand front and rear side stops are now precisely aligned.

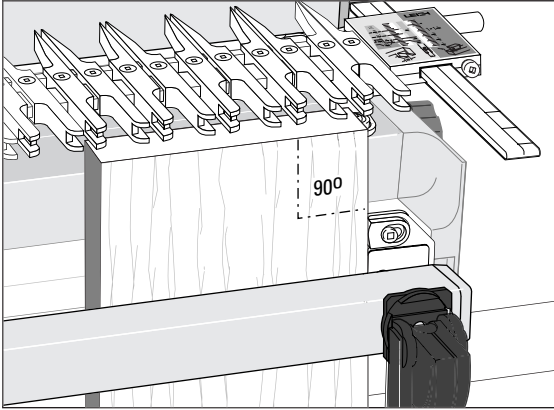
**1-31**

Remove the boards from the left side of the jig. Make sure the support brackets are still in the fully raised position. Temporarily re-install the finger assembly onto the support brackets (any mode). Repeat the side stop bumper setting procedure on the front right side of the jig.

Then remove the finger assembly and repeat the alignment procedure for the rear right side stop.

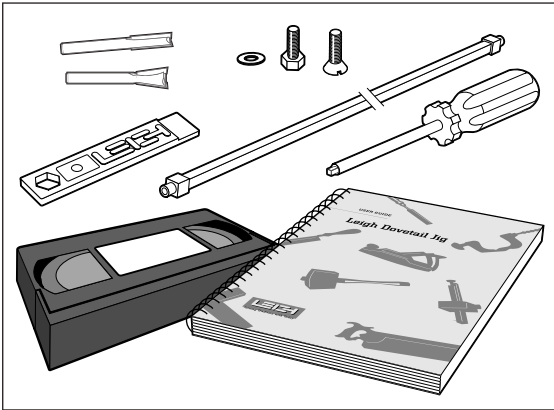
**1-32**

After you have assembled and mounted the jig, you will have some items left over:

- 1 straight router bit Leigh No.140
 - 1 dovetail router bit Leigh No.80
 - 1 Leigh wrench/gauge/angle sidestop
 - 1 angled sidestop bolt and washer
 - 1 accessory attachment screw
 - 1 Leigh guidefinger adjustment screwdriver
 - 1 cross cut bar with plastic caps
 - 1 Instructional Video, and this manual.
- Please keep all these items for ready use.

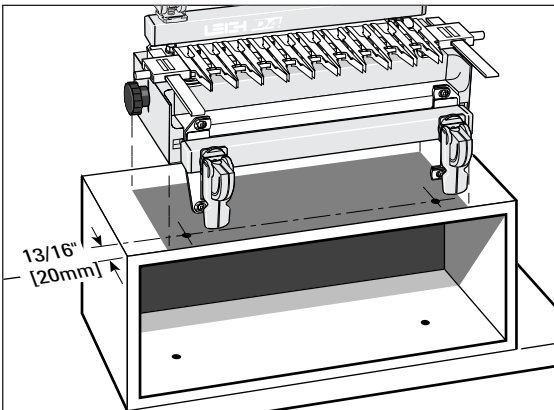
**1-33**

To gain height for a more comfortable working position or for routing longer boards, mount the jig to a box that can be bolted securely to a bench.

(see also page 145 fig. 17-14)

CHAPTER 2

Adjusting the Finger Assembly

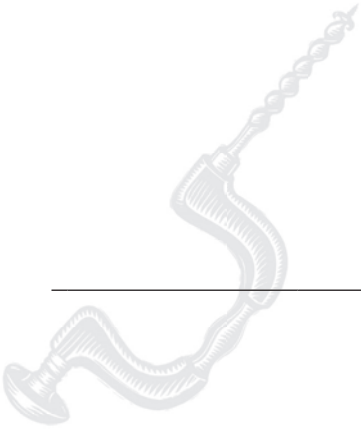

Chapter Foreword

The finger assembly is the heart of the Leigh jig. Spend a few minutes now to familiarize yourself with these simple adjustments.

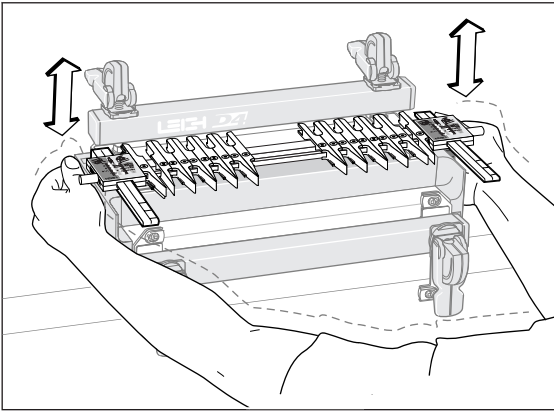
**2-1**

Practice with the finger assembly height adjustment. Loosen the support bracket knobs and hold them firmly. Raise and lower the assembly evenly, keeping it level, and tighten the knobs to lock it at various heights.

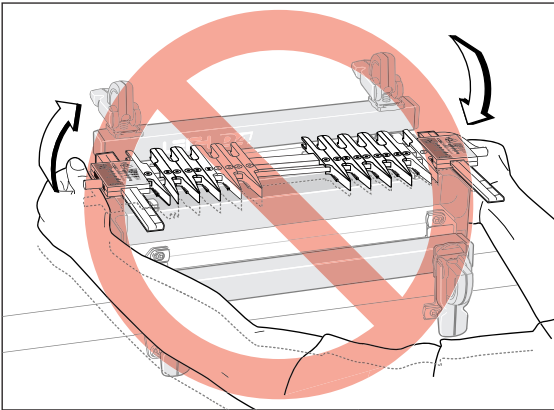
**2-2**

Do Not raise or lower one end of the finger assembly at a time.

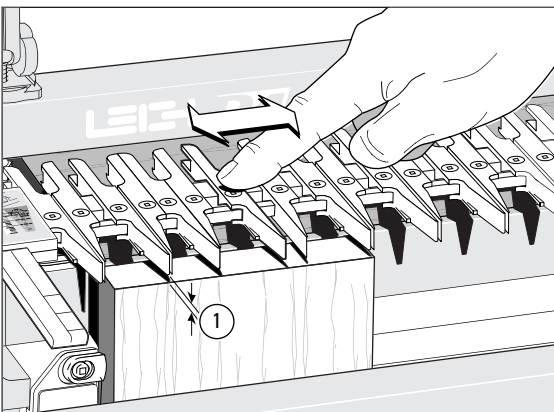
**2-3**

To practice adjusting the guidefingers, put a board in the front clamp. Always raise the finger assembly slightly, approximately $\frac{1}{16}$ " [2mm] ① above the spacer board and/or workpiece. This is essential to allow the guidefingers to move freely on the guidefinger bar and ensures that the fingers will be level and flush when locked up. Move the guidefingers by pushing on the middle to slide them along the guidefinger bar.

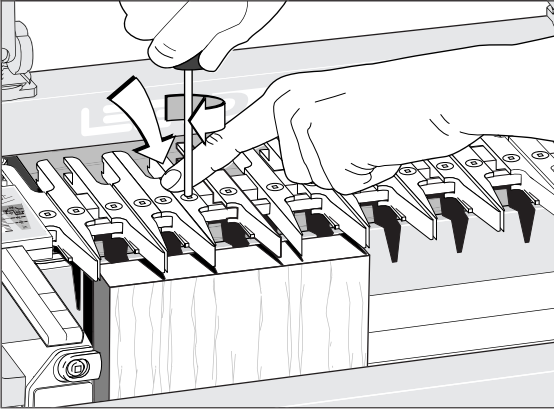
**2-4**

Loosen about half the guidefingers and practice unlocking, moving, positioning and relocking them. **Always press on the centre of the guidefinger when tightening the screws.**

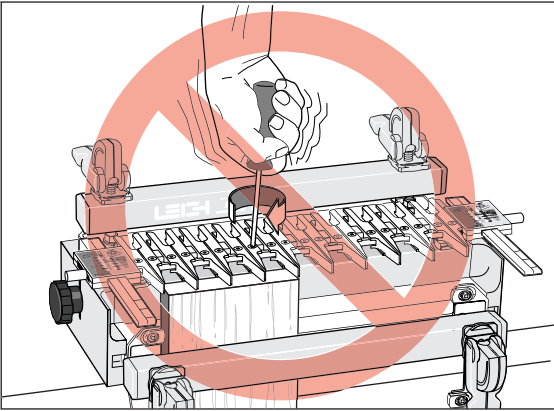
**2-5**

Do Not over-tighten the guidefinger lock screws. The Leigh screwdriver provided will give ample torque for easy lock-up without strain.

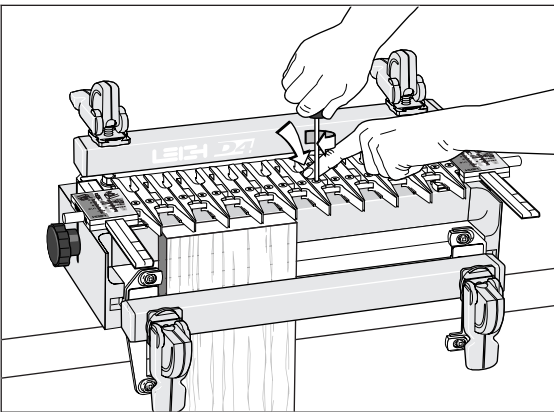
**2-6**

Always tighten unused guidefingers before routing, as router vibration may cause loose screws and wedge nuts to fall out and be lost.

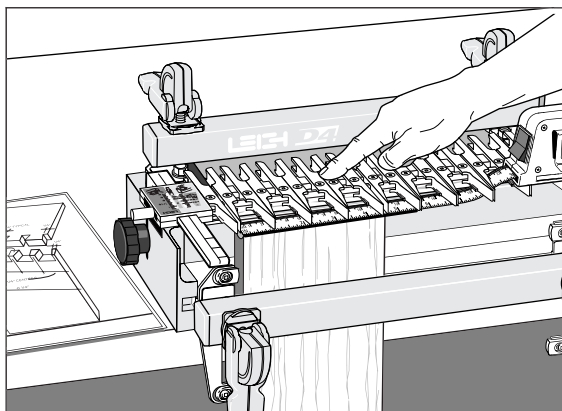
**2-7**

You can adjust the guidefingers by eye, or by measurement to suit a set of plans.

Note: Always lower the finger assembly down onto the workpiece before routing.

How Routers with Guidebushes Work

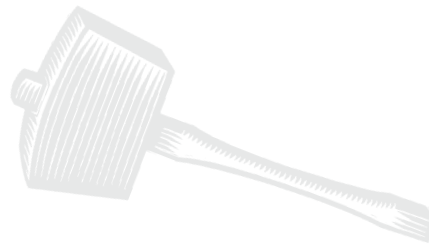
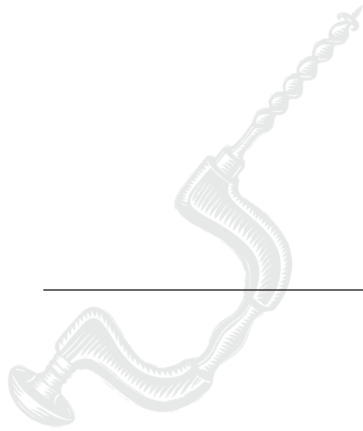

Chapter Foreword

The guidebush is the vital link between router and jig. Here's how it works.

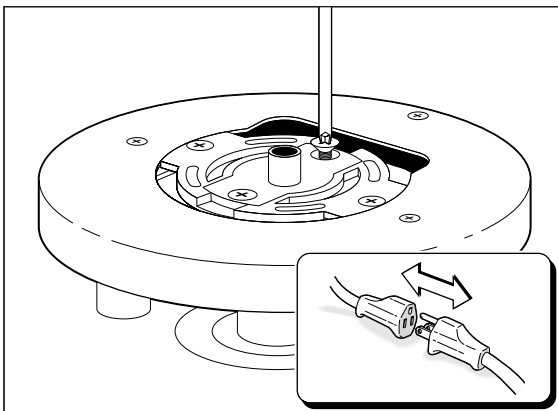
**3-1**

The guidebush attaches to the base of the router and is fixed. It does not rotate.

 Only two sizes of guidebush are used with the Leigh Jig:

$\frac{7}{16}$ " [11,1mm] OD (outside diameter), and $\frac{5}{8}$ " [15,9mm] OD.

See page 151 "Guidebush Selection".

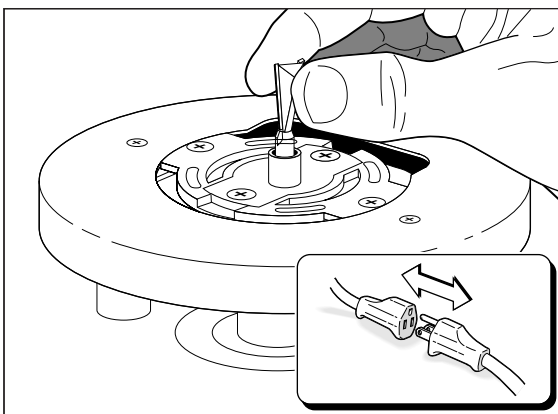
**3-2**

The cutter or bit goes through the guidebush and fits in the router collet or chuck.

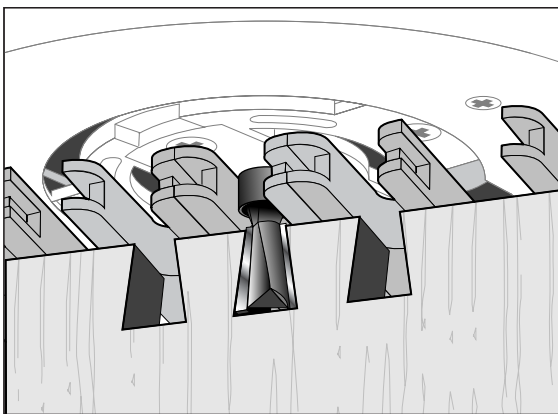
**3-3**

The projecting part of the guidebush runs along the side edge of a guide. The rotating cutter cuts the wood only, and touches neither the guidebush nor the guide surface.

Operation Concepts and Basic Jig Functions

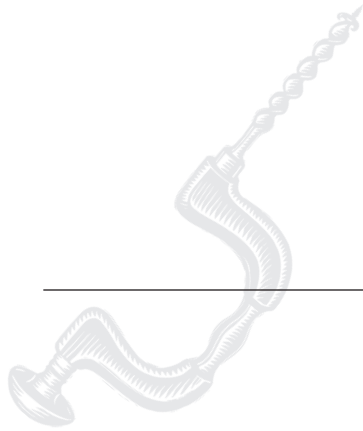

Chapter 4 D4 User Guide

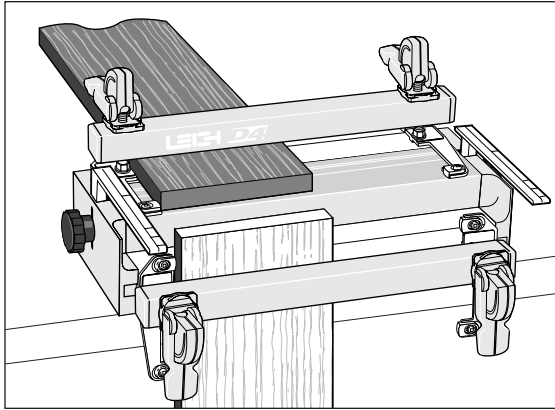

4-1

The two clamp bars hold workpieces horizontally or vertically. The side stops align the boards in the same position each time.

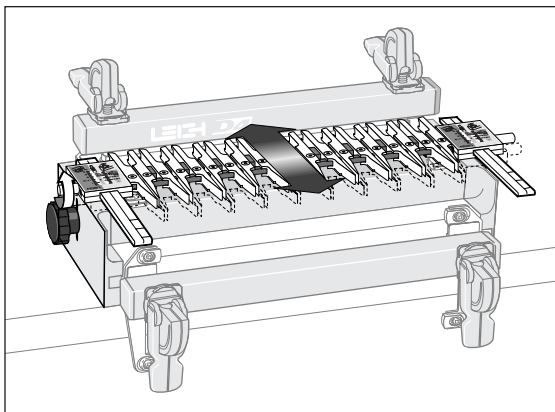

4-2

The guidefinger assembly slides on to the support brackets above the workpiece. The finger assembly is adjusted in or out using calibrated scales on each end to suit different thicknesses of vertical boards.

Note: The single rear indicator line on each support bracket is the only mark used in this guide. The front three lines are for the (optional) multiple mortise & tenon attachment.

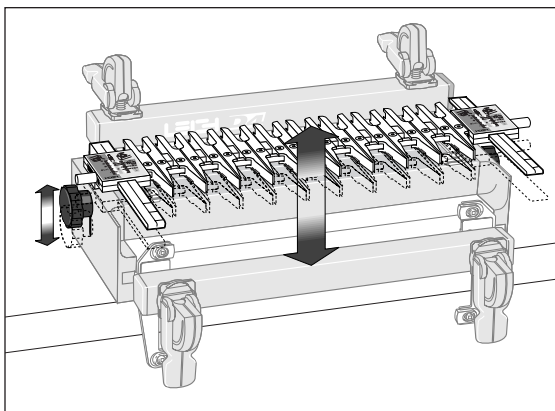

4-3

The finger assembly is raised or lowered using the support brackets to suit different thicknesses of horizontal boards.

THE FOUR SCALE MODES

The Finger Assembly attaches to the support brackets in four different modes to match the type of joint you are cutting.

This line is for the finger assembly scales. **The line is illustrated in red for clarity, but is black on the jig.**

These three lines are used only with the optional multiple mortise & tenon attachment.

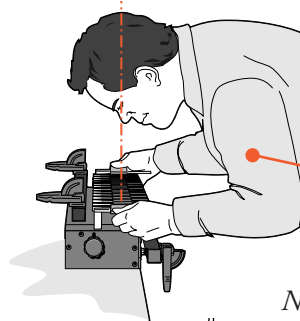

Always read scales from directly overhead to avoid parallax problems.

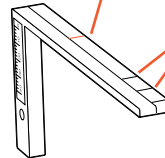

Note: Inch scales are shown here. Millimetre scales have identical layout.

The active scale is always on the right of each scale assembly.

The inactive scale is always on the left of each scale assembly and is upside-down.

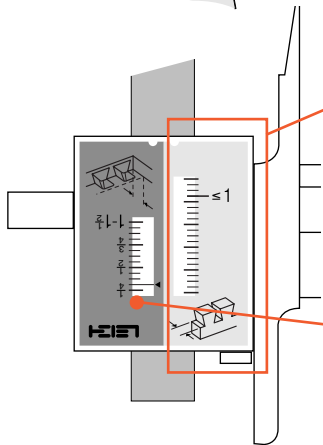

1. TD TAILS

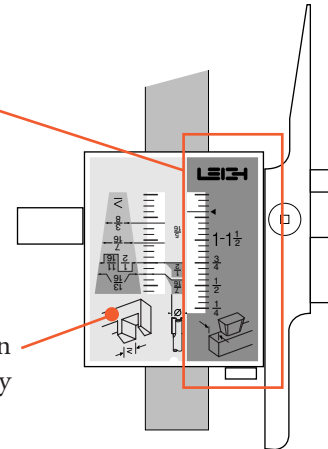

3. HB TAILS

Each scale has its own mode icon (a drawing of the joint part made in that mode).

Scales are colour coded.
Silver background for Through Dovetails.
Green background for Half-Blind Dovetails.

The specific settings for each scale are fully described in the appropriate chapters.

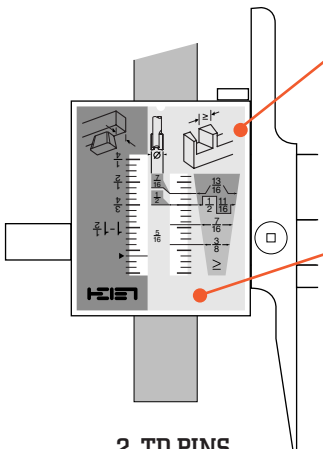

2. TD PINS

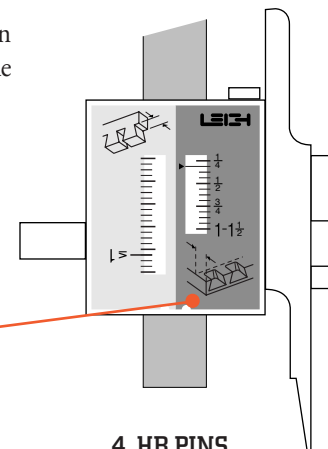

4. HB PINS

Chapter 4 D4 User Guide

CONCEPT OF JIG OPERATION – **THROUGH DOVETAILED**

Start with the Finger Assembly in the  TD TAIL mode and follow these steps on your jig. Grasping the simple basic concept of operation will greatly assist you in understanding the instructions. *Note that the active guide surface (against which the guidebush runs) is indicated in red in the illustrations.*

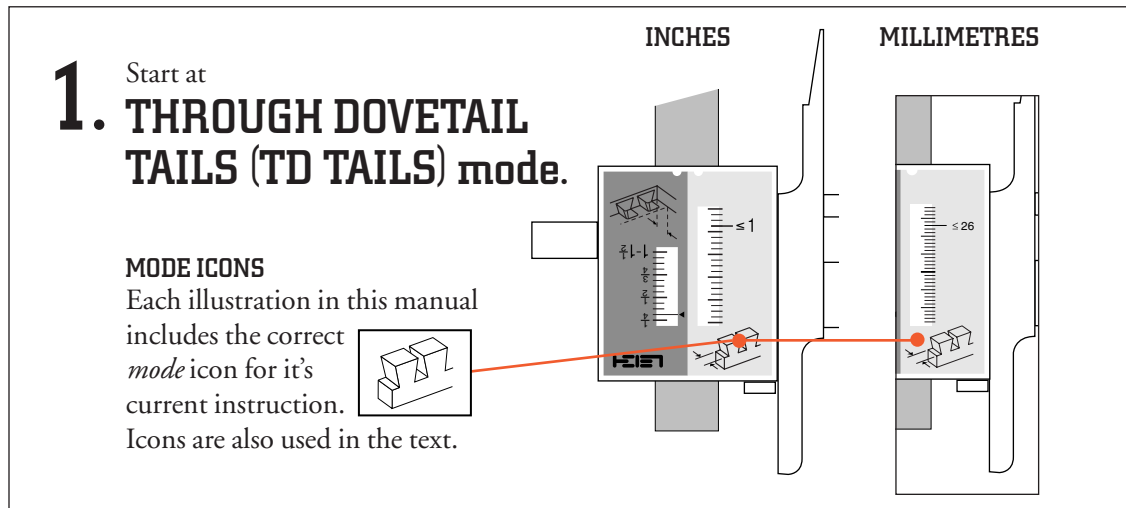

2. ROTATE
Rotate the finger assembly toward you 180°.

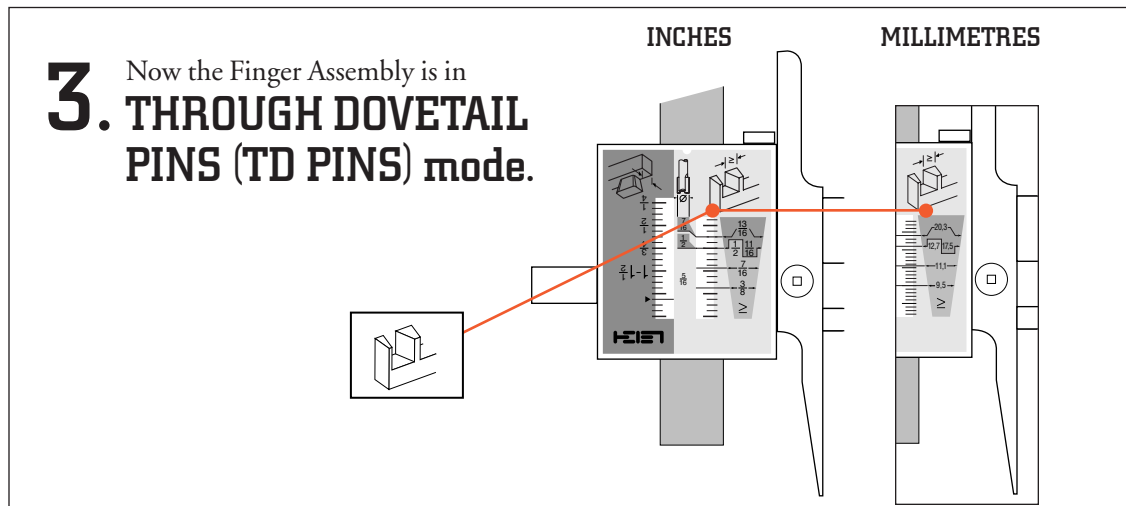

4. FLIP
Flip the Finger Assembly end-over-end 180°
(to Half-Blind Dovetail Pins, Page 30)

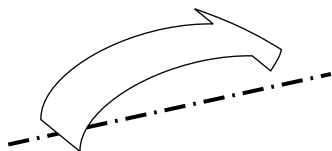
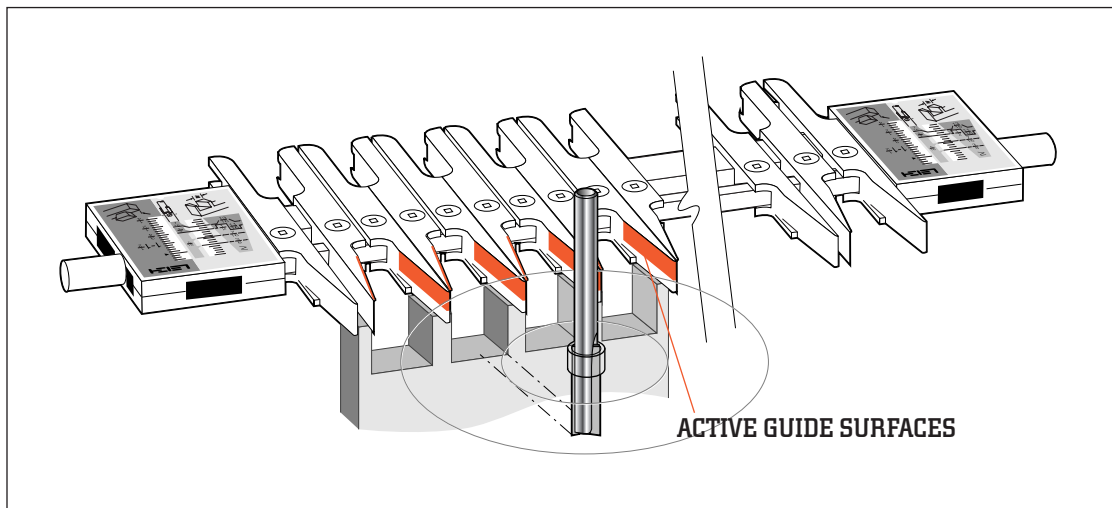
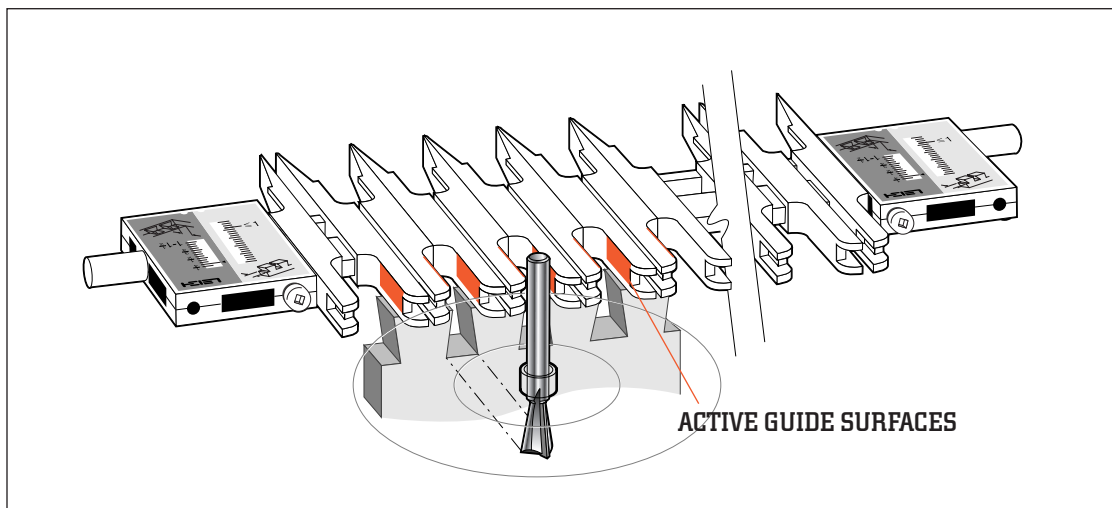

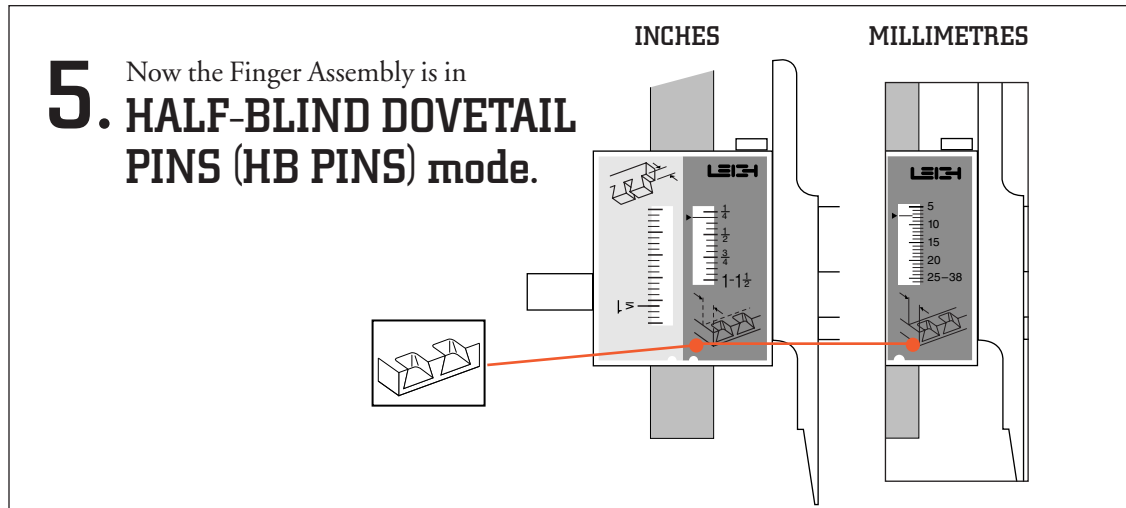
CONCEPT OF JIG OPERATION – **HALF-BLIND DOVETAILS**

6. ROTATE Rotate the finger assembly toward you 180°.

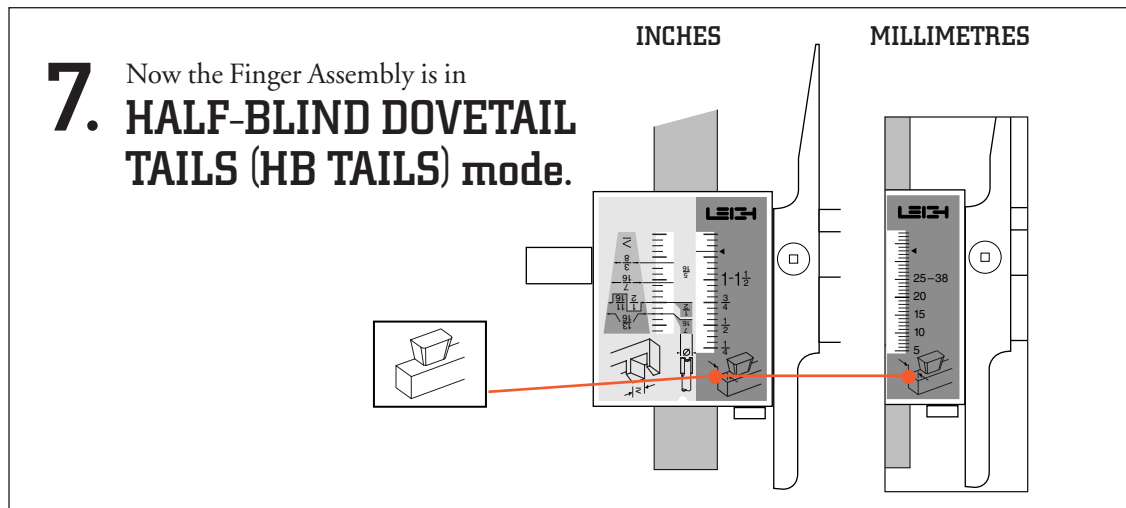

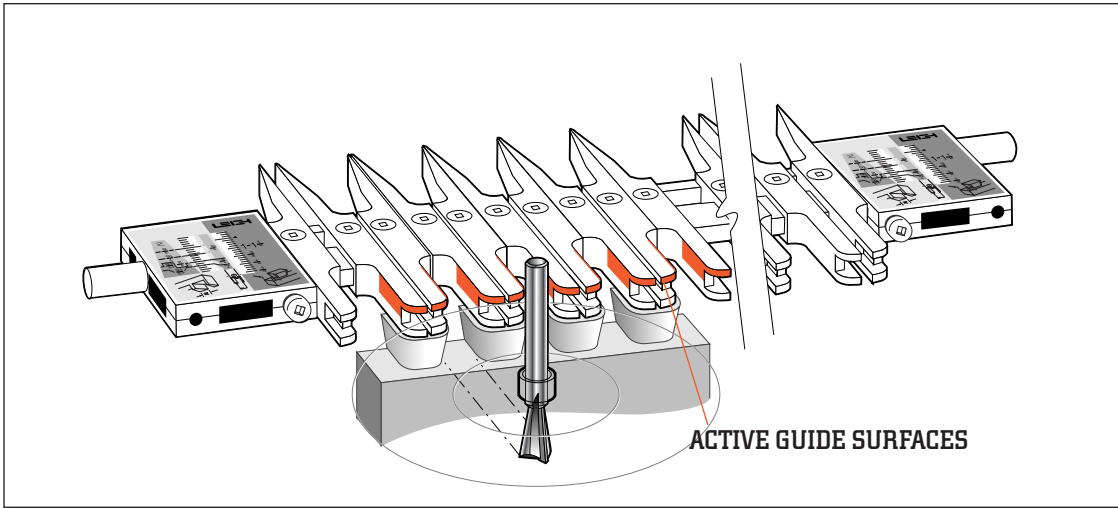
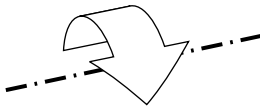
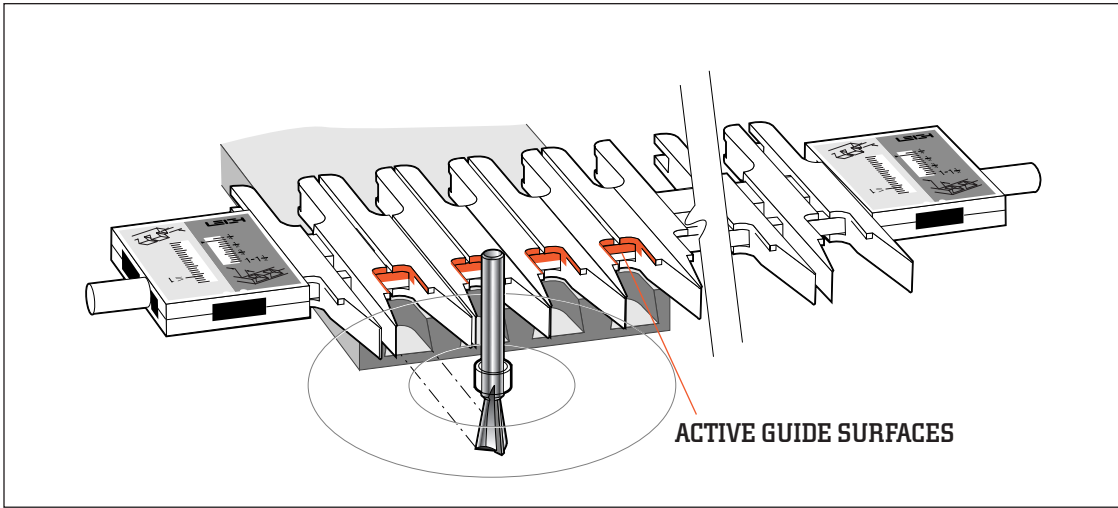

Chapter 4 D4 User Guide

CONCEPT OF JIG OPERATION - SLIDING DOVETAIL JOINTS

The HB TAILS mode is also used with the cross-cut bar to cut sliding dovetail joints.

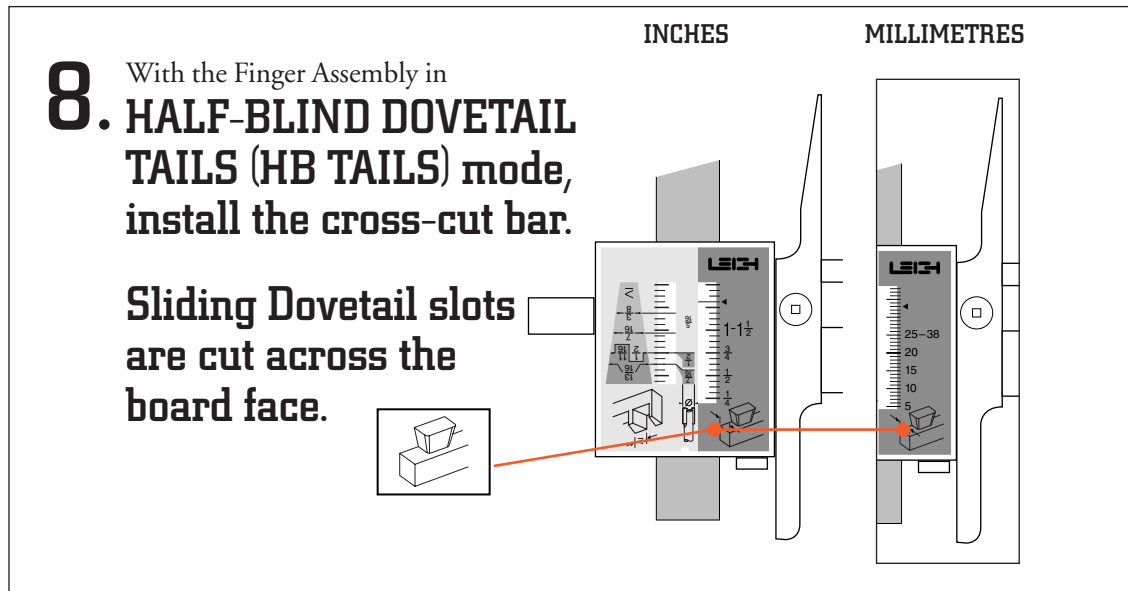

Keep the finger assembly

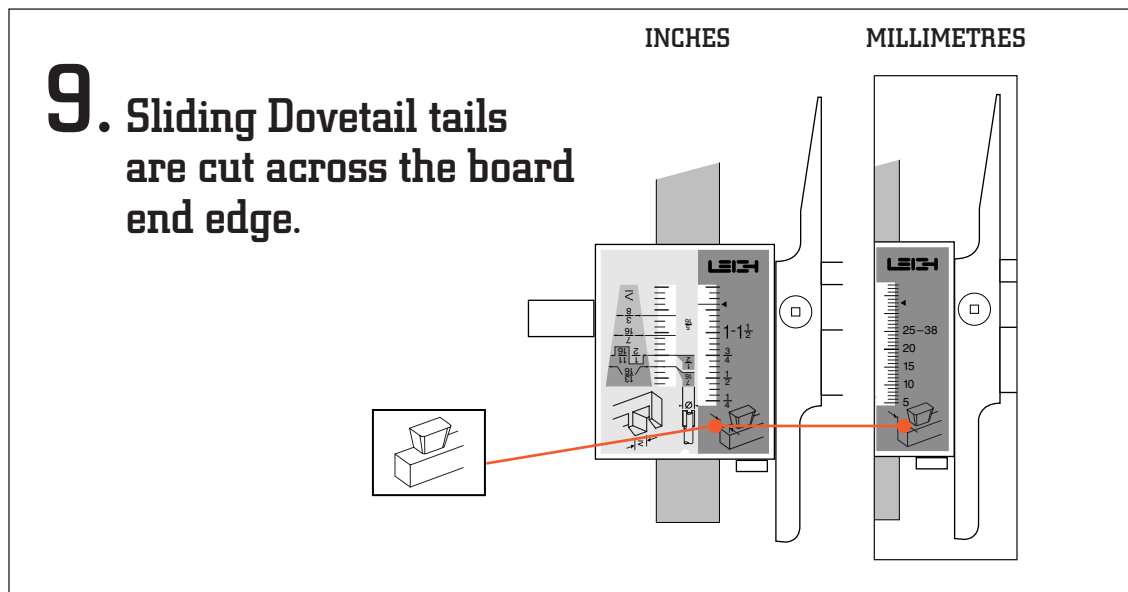

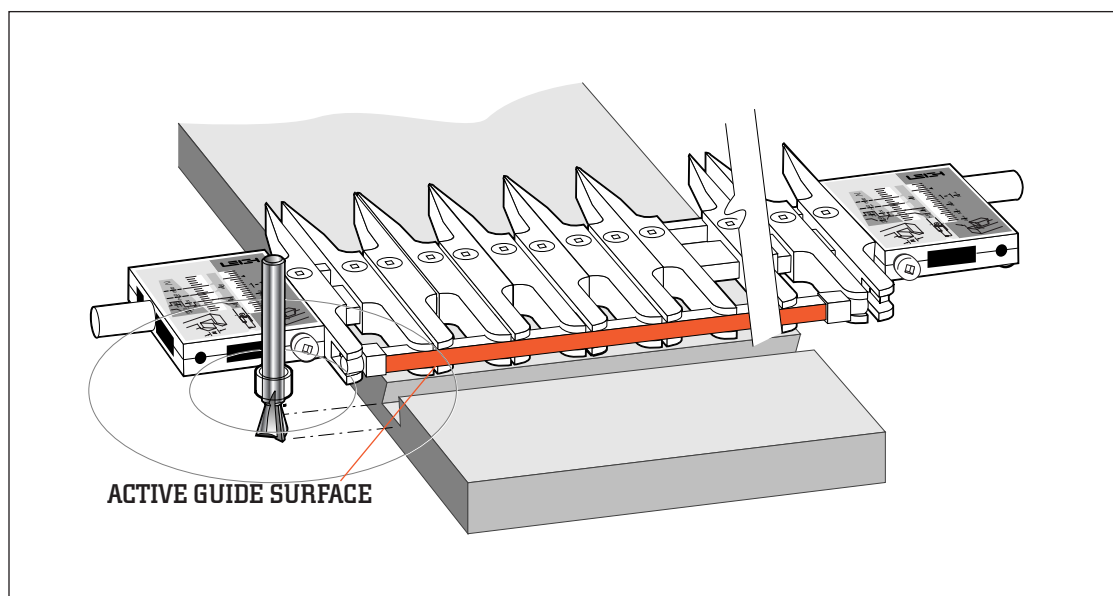

in the same mode.

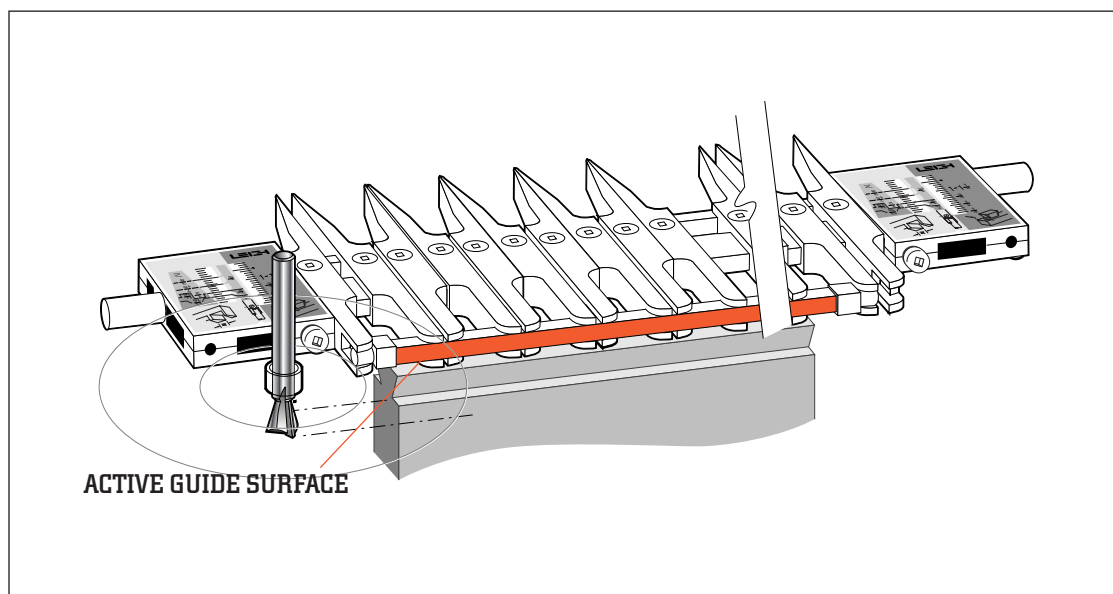

Using Your Jig Safely

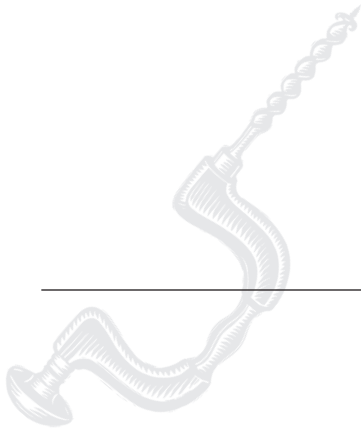

Chapter Foreword**Safety is not optional.**

Read and follow the recommendations in this chapter.

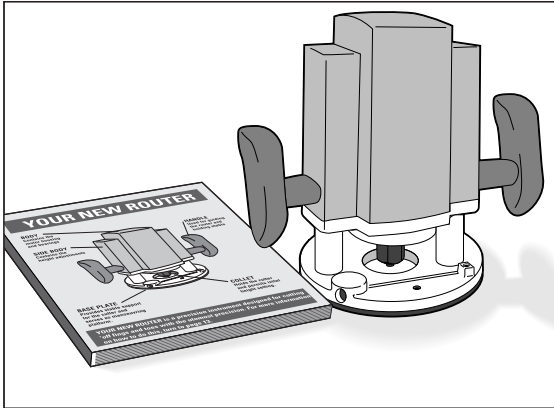

5-1
Read the owner's manual that came with your router. It is essential to understand the router manufacturer's instructions completely.



5-2
Always wear hearing protection when using a router.

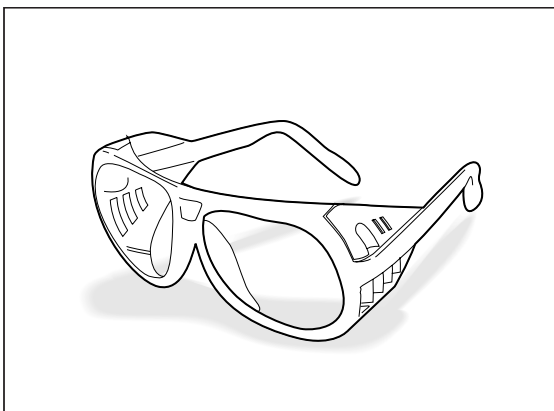

5-3
Always wear approved safety glasses when using a router.

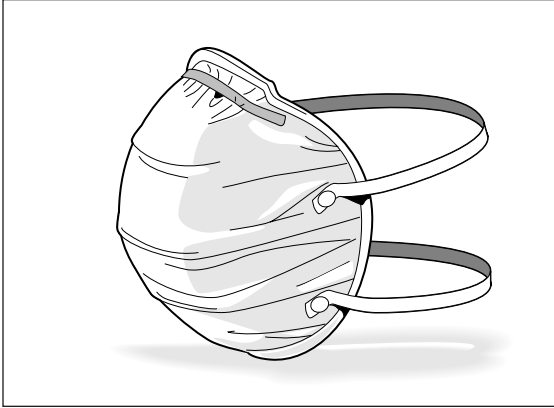
**5-4**

Protect yourself from harmful dust by wearing a face mask.

**5-5** 

Never drink alcohol or take medications that may cause drowsiness when you will be operating a router.

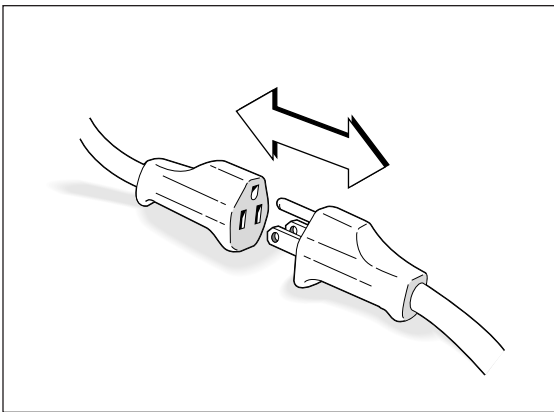
**5-6**

Always disconnect the power source from the router when fitting cutters or guide-bushes, or making adjustments.

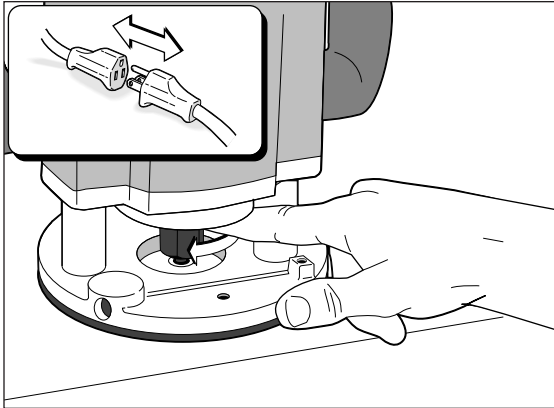
**5-7**

Before connecting the router to the power source, make sure the cutter and collet revolve freely in all the areas you plan to rout, and the cutter does not touch the guidebush or jig.

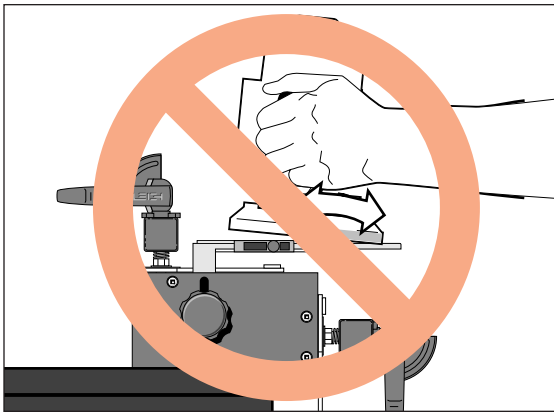
**5-8**

Do not tilt the router on the jig.

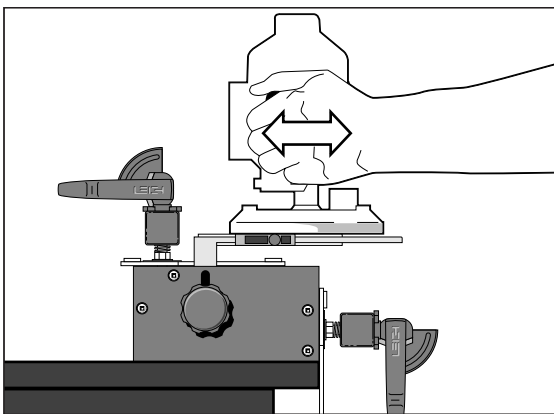
**5-9**

Keep the router flat on the jig assembly.

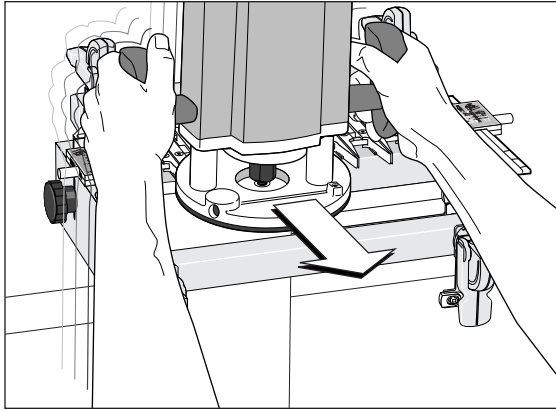

5-10  If you insist on removing the router from the jig while it is still revolving, **always pull it straight off the jig horizontally, and do not raise or lower the router until it is completely clear of the jig.**

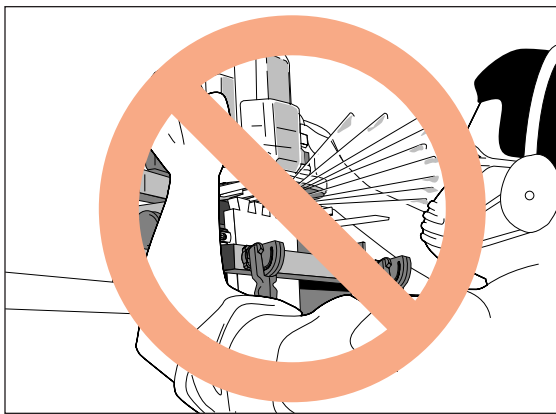

5-11  **Do not rout at face level.**

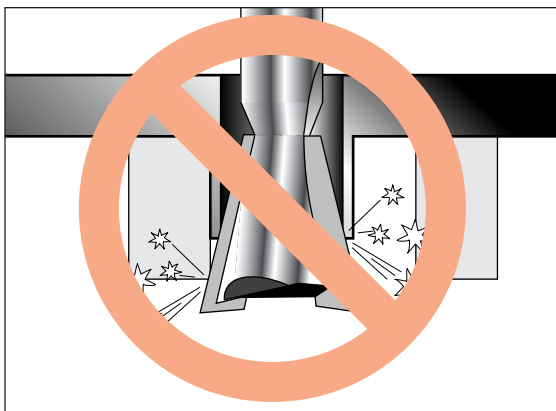

5-12  **Never release the router plunge mechanism when using dovetail cutters. Check if your plunge router has a stop nut to prevent this from happening.**

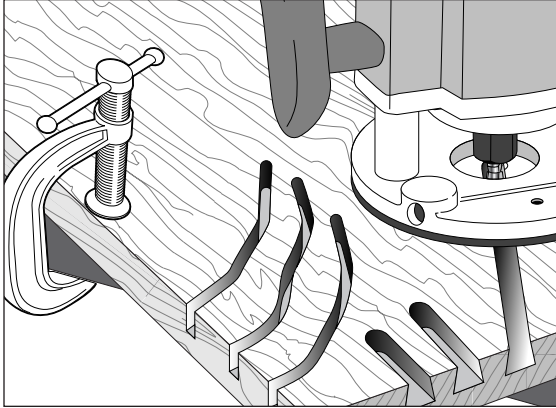
**5-13**

If you have never used your router before, be sure to follow the router manufacturer's instructions for its use. Make plenty of simple open-face practice cuts *without a guidebush* before you try to use the router on the Leigh jig. You must, of course, always use a guidebush when routing on the Leigh Jig.

Wood Preparation

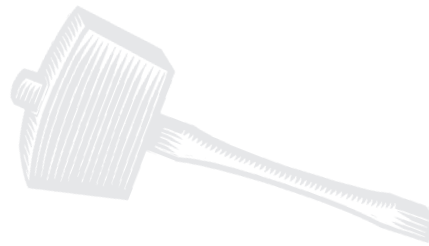
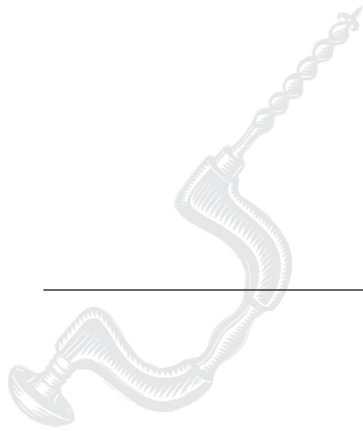

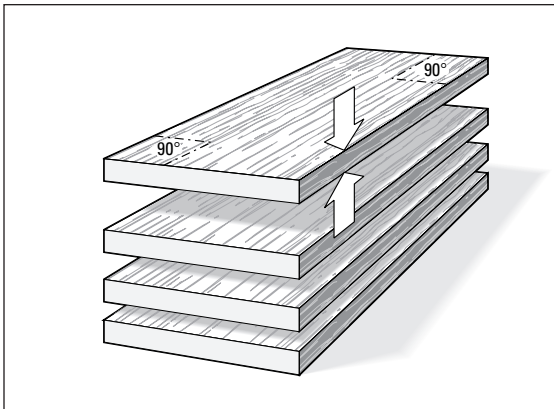

**6-1**

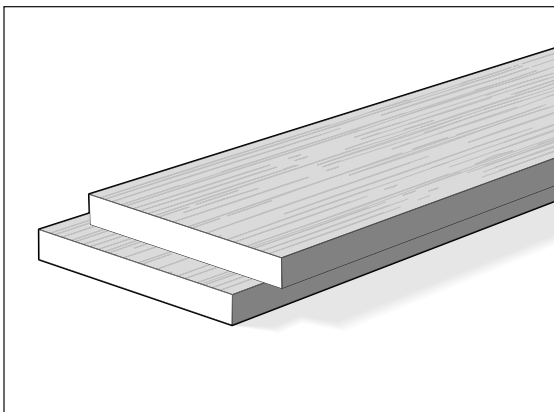
Stock for use on the Leigh jig should generally be prepared straight, flat, of even thickness and equal widths, with square ends and edges. The jig will work with boards of many odd shapes, but make sure the jig can function properly with the required shape of board before you try to use it on a project workpiece. **Note that plywood is generally unsuitable for routing because of tearout problems.**

**6-2**

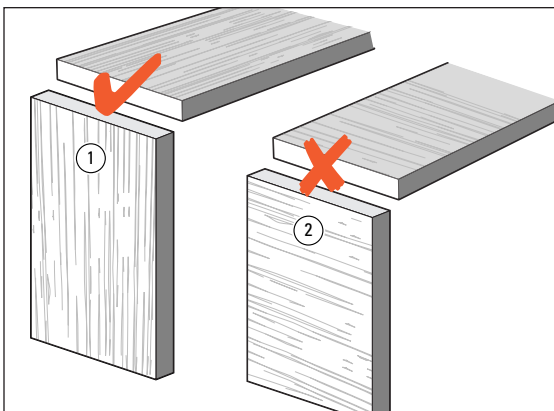
You will want to test the jig, so prepare some $\frac{3}{4}$ " x $5\frac{1}{2}$ " [20x140mm] boards. Cut them to length as you need them for the jig tests you want to perform. Use them for practice with the jig's various joint modes so you can see how the different modes work. **Remember, though, that boards of unequal thicknesses can be joined just as easily.**

**6-3**

 Dovetail joints are intended for joining end grain to end grain ①. Attempting to cut dovetails in side grain ② does not work because:

- The wood will tear out badly when routing.
- Even if you could rout them, the pins and tails would easily break off across the short grain.

Router Preparation

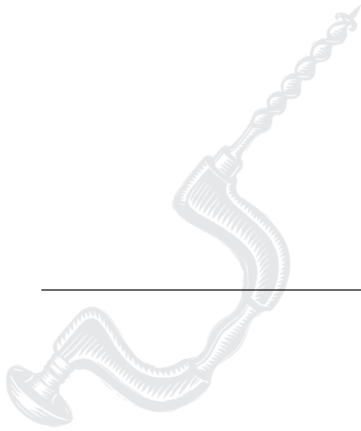

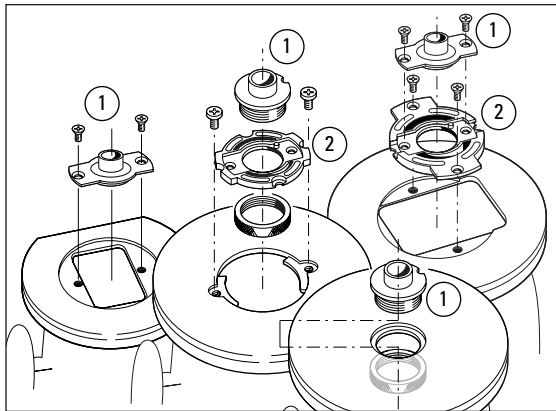
**7-1**

The router of course, must always have the correct size of Guidebush fitted ①. Only two sizes are used for dovetailing, $\frac{7}{16}$ " [11,1mm] O.D. for all halfblind and smaller through dovetails, and $\frac{5}{8}$ " [15,9mm] O.D. for the largest through dovetail joints. Your router base may also require a guidebush adapter ②. Please see Appendix I, page 149 "Guidebush Selection".

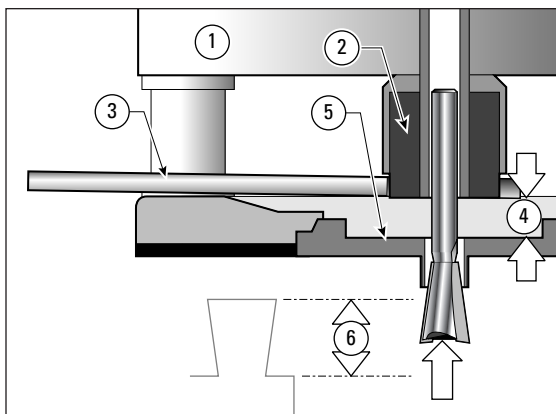
**7-2**

When fitting a cutter to the router ①, **always fit the cutter shank as deeply into the collet ② as possible.** Always rout with the collet as close to the cutter head as possible. Usually you will not be able to get the collet wrench ③ securely on the collet nut with the collet at its optimum low position, so fit the cutter into the collet so that the remaining travel ④ between the collet and the guidebush ⑤ will let the cutter reach the required depth of cut ⑥.

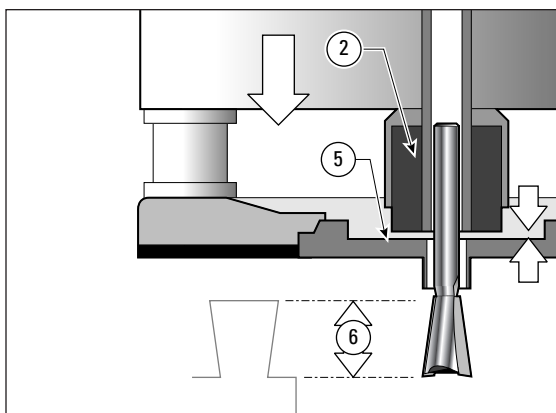
**7-3**

Tighten the collet ② securely and lower the collet to adjust the depth of cut ⑥, but make sure the collet does not contact the guidebush ⑤.

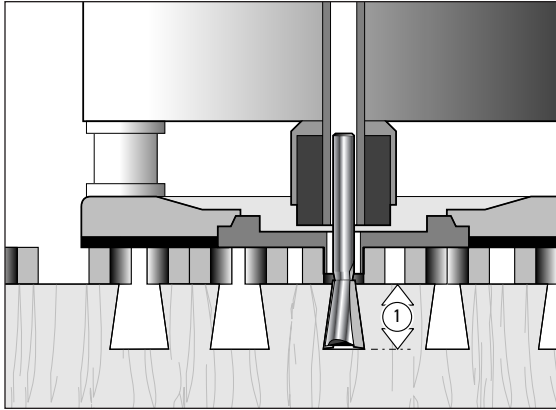
**7-4 Depth of Cut:**

The depth of cut always refers to the actual depth ① of the cut into the wood beneath the guidefingers.

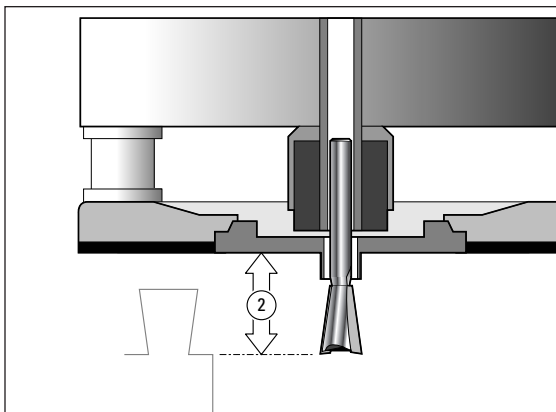
**7-5**

Depth of cut is not the distance the cutter projects from the router base. This is cutter projection ②. This manual will always refer to depth of cut. (Cutter projection ② is always .450" [11.5mm] more than depth of cut).

Through Dovetail Procedures



Chapter Foreword

In these instructions for using the Leigh Dovetail Jig, we have recommended using certain cutters and board sizes just because they are easy to work with. When you have cut some practice joints and gained confidence in your ability to get the results you want, feel free to use the guidebush and cutter selection charts on pages 149 and 155 to plan whatever dovetail routing you need for your own projects.

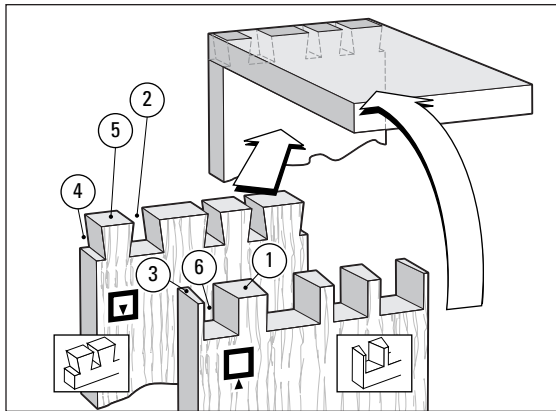
**8-1**

Through Dovetail Terminology:

- ① Pins
- ② Pin sockets
- ③ Half-pins
- ④ Half-pin sockets
- ⑤ Tails
- ⑥ Tail sockets

The pins fit in the pin sockets. Joints almost always end each side with half-pins.

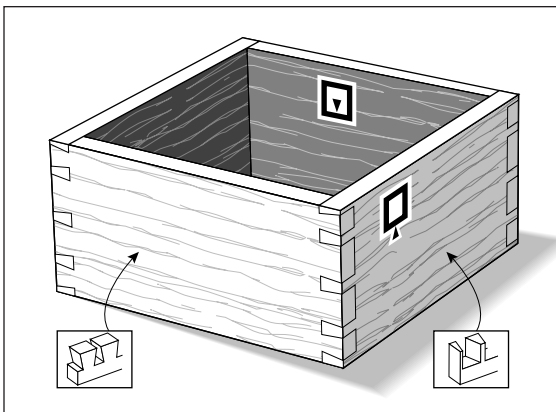
**8-2**

Let's look at how to make a simple square box.

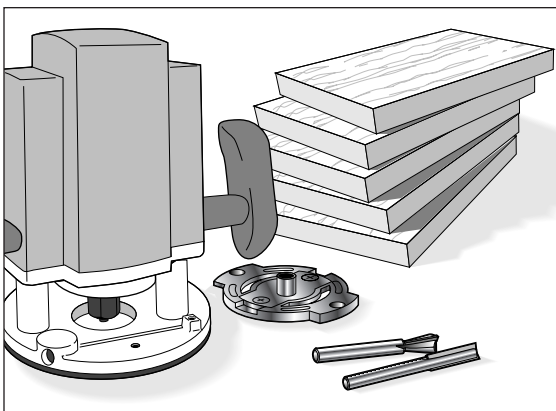
**8-3**

You will need five identical boards $\frac{3}{4}$ " x $5\frac{1}{2}$ " [20x140mm] x 8" [200mm] or so long (the fifth board may be used up doing the initial testing for fit). Mark the inside and outside faces of each board. For this trial use a router with a $\frac{7}{16}$ " [11,1mm] O.D. guidebush and a No. 80 or 80-8 $\frac{1}{2}$ " [12,7mm] x 8° dovetail cutter and a No.140 or 140-8 $\frac{5}{16}$ " [7,9mm] straight cutter (see the cutter and guidebush selection charts in the appendix).

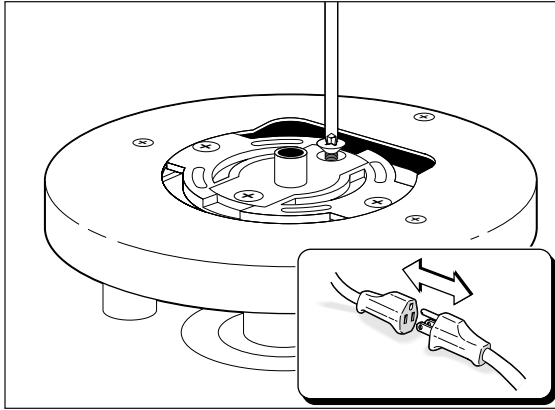

8-4
Fit the $\frac{7}{16}$ " [11,1mm] guidebush securely to the router.

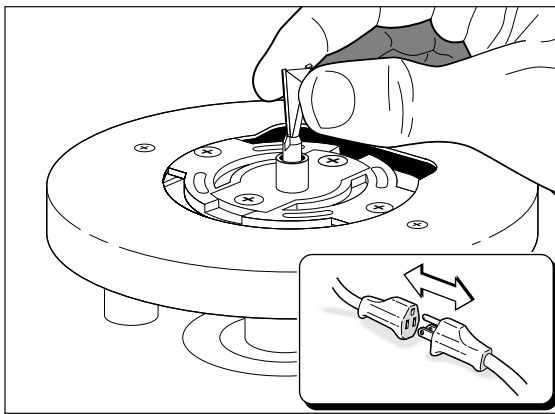

8-5
Fit the 80 or 80-8 dovetail cutter to the router.

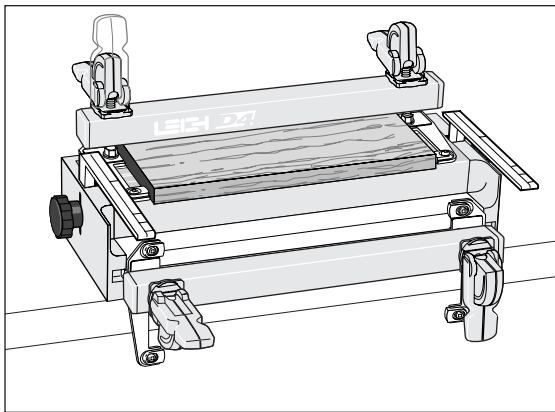

8-6
Clamp the spacer board in the rear clamp. To simplify the instructions, some illustrations will show a jig considerably shorter than the standard 24" [610mm] jig.

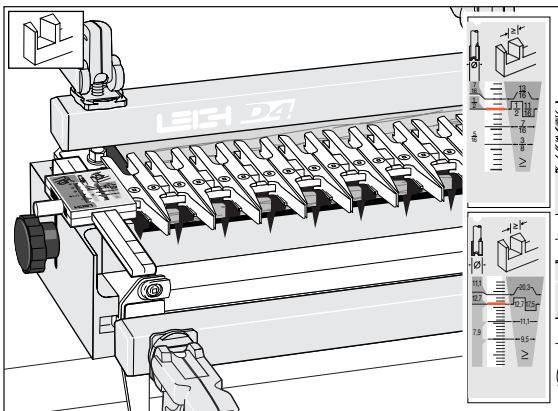
**8-7**

Place the finger assembly on the support brackets in the TD PINS mode, flat on the spacer board, and with the scale set on the $\frac{1}{2}$ " [12,7mm] setting for now. Don't worry about the scale's specific meaning now. Each scale's use will be fully explained in the appropriate section.

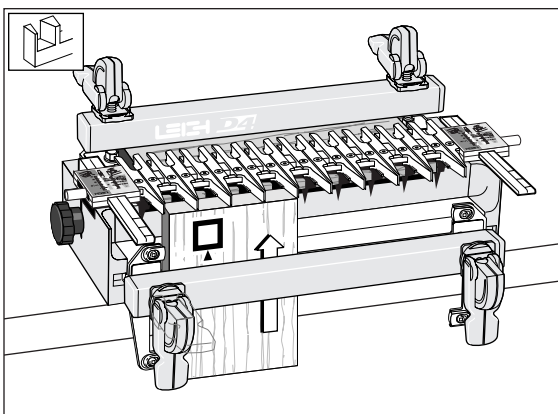
**8-8**

Although you will cut the tails first, adjust the guidefinger layout in the TD PINS mode. The adjustment screws are on top in this mode, and it is easier to visualize the finished joint pattern. **Clamp one of the pin boards** in the left side of the front clamp, against the side stop, with the top edge flush under and touching the guidefingers, and the outside face \square away from the jig body.

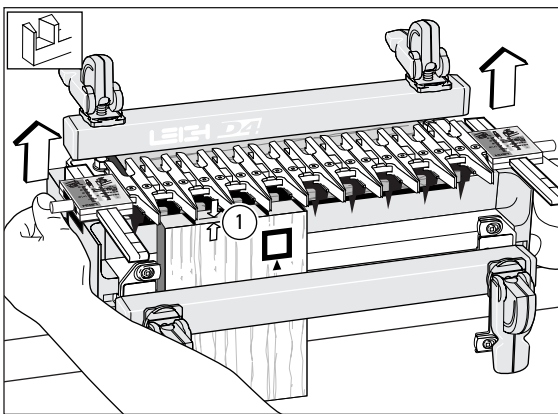
**8-9**

Loosen the support bracket knobs and raise the finger assembly about $\frac{1}{16}$ " [2mm] ① above the boards and retighten the knobs. This will allow easy and accurate guidefinger adjustment.

Chapter 8 D4 User Guide

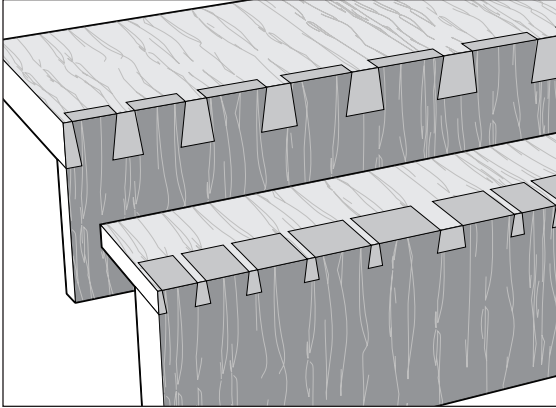
**8-10**

The following joint design is only a suggestion for this trial. It has a typical and traditional symmetrical layout of pins, with half-pins at each edge. The Leigh jig, however, allows for an infinite variety of joint designs, and boards of different thicknesses can also be joined to each other as shown in this illustration. Before attempting joints of asymmetrical design, please see chapter 13.

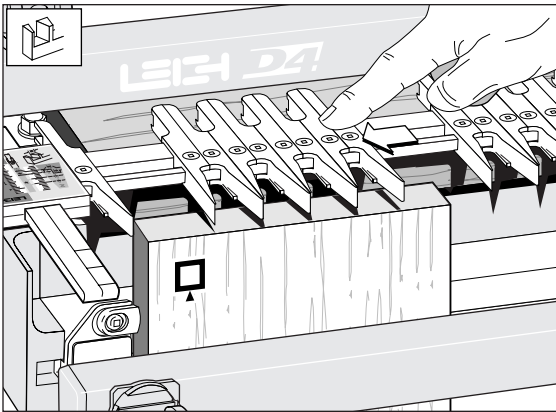
**8-11**

Ignoring the extreme outer guidefinger next to the scale (it just supports the router), loosen the next eight guidefingers and slide them over the top of the workpiece.

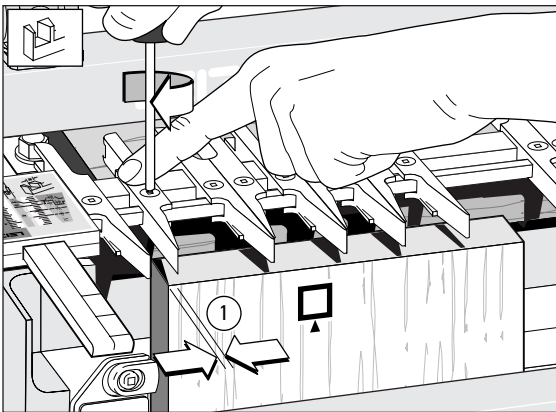
**8-12**

Lock the left-most half-pin guidefinger about $\frac{1}{8}$ " [3mm] ① in from the left edge of the board.

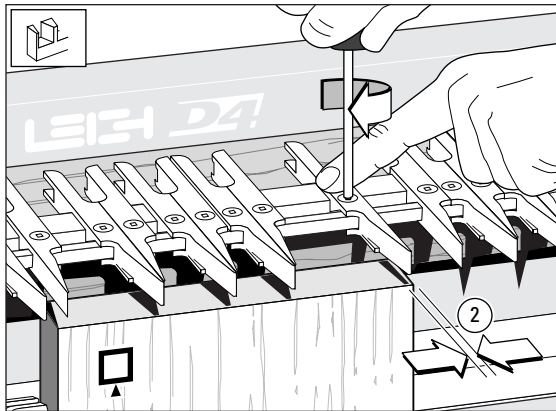
**8-13**

Leave three pairs of guidefingers over the board and lock the right-most half-pin guidefinger about $\frac{1}{8}$ " [3mm] ② in from the right edge of the board. Judge this distance by eye: it need not be exact. The sockets and pins will align automatically.

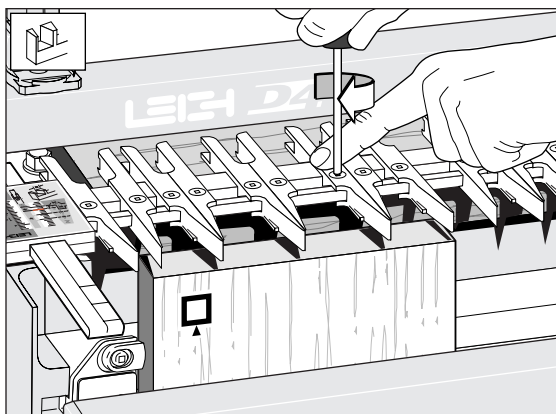
**8-14**

Space and lock the three remaining pairs as shown. Again, judge it by eye. If it looks right on the jig, the finished joint will look right.

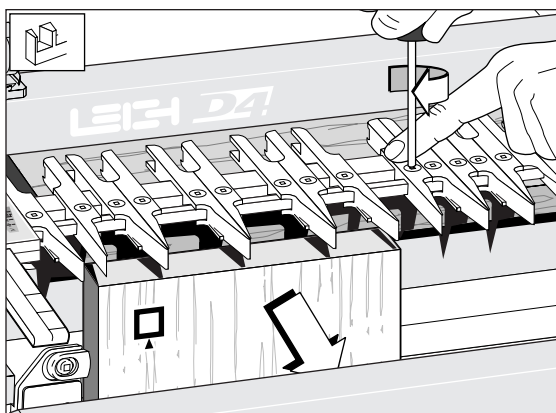
**8-15**

Tighten any other loose guidefingers and remove the pin board.

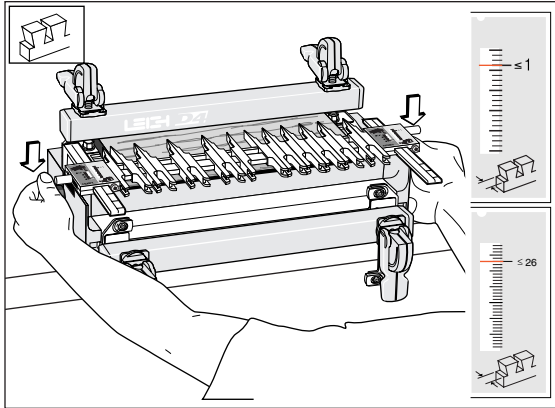
**8-16**

Rotate the finger assembly to the TD TAILS mode, and set it to the $\leq 1''$ [$\leq 26\text{mm}$] position on the scale. Lower the finger assembly onto the spacer board. All TD tails are routed at this $\leq 1''$ [$\leq 26\text{mm}$] setting.

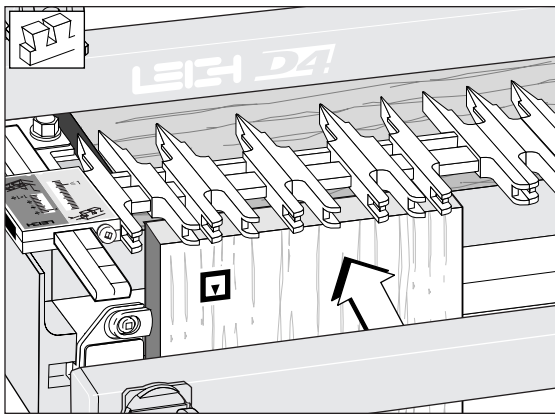
**8-17**

Clamp the tail board vertically, with the inside face of the board away from the jig.

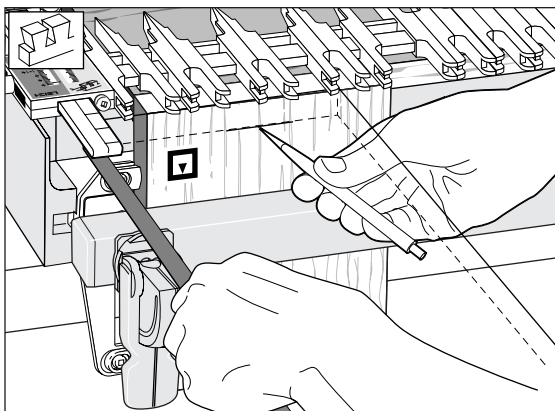
**8-18**

Place the end of a pin board horizontally flush under the guidefingers and mark a thin pencil line partly across the tail board.

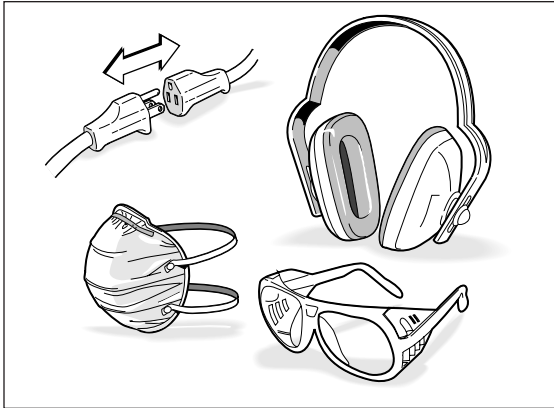
**8-19**

Remember to follow all safety precautions when routing.

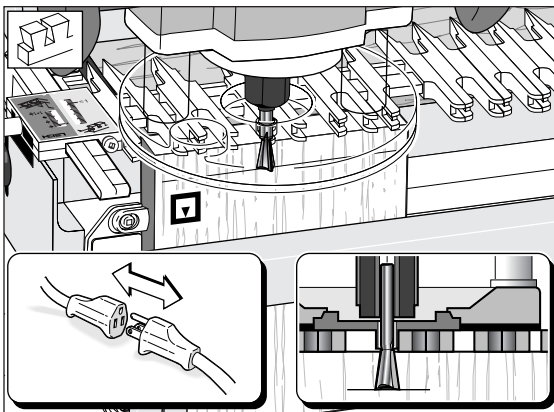
**8-20**

Place the router on the finger assembly and adjust the router until the dovetail cutter tip is level with the centre of the pencil line.

Note: This means the pin socket will be half a thin pencil line deeper than the thickness of the pin board, leaving minimal clean-up after assembly.

Check to make sure the cutter rotates freely.

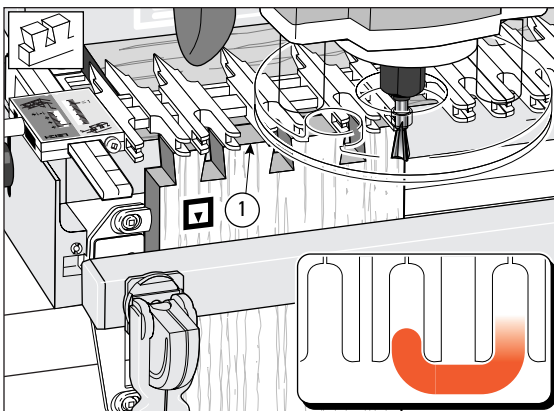
**8-21**

Plug in the router and rout out the half-pin and pin sockets. Use **only light side pressure on the guide fingers**. Take care not to rout unwanted sockets where there are gaps between the pairs of fingers ①. Rout only between the rounded guidefinger tips. See 17-19 in *Hints and Tips*.

Before removing the routed board from the jig, check by eye and touch to make sure no parts have been missed. See page 143 for *Hints and Tips* on how to minimize tearout.

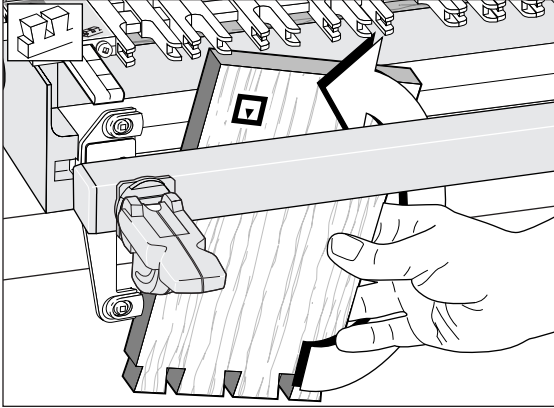
**8-22**

Release the clamp and reverse the tail board in the jig, keeping the same inside face  away from the jig body.

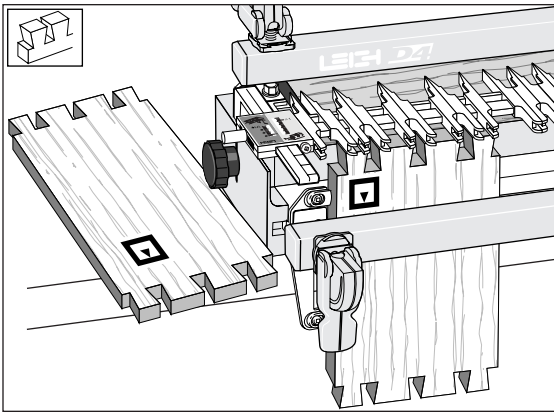
**8-23**

Rout the other end of this tail board and both ends of the second tail board in the same fashion.

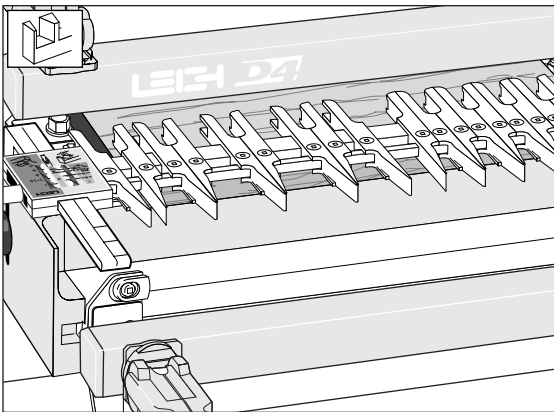
**8-24**

Rotate the finger assembly to the  TD PINS mode. **Do not change the guidefinger layout.**

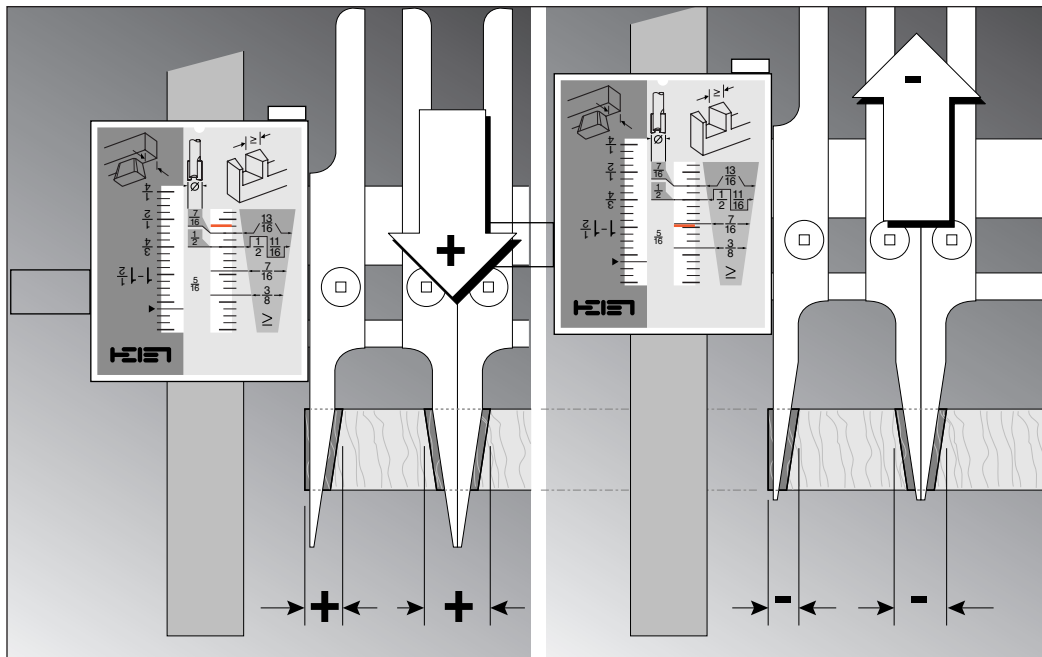

8-25

The tightness of the finished joint is determined in the TD PINS mode. The farther out toward the operator the finger assembly is set, the larger the pins will be. Setting the finger assembly farther in will make the pins smaller. (The outer, non active support finger is not shown in this illustration).

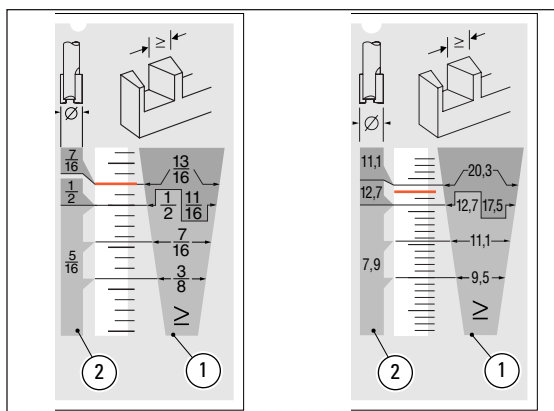

8-26

The TD Pin scale ① looks like a pin. The dimensions in this pin-shaped panel indicate the width of pin to be routed. These dimensions match the size of dovetail cutter used to rout the tails. Manufacturing tolerances of routers, cutters and guide-bushes make it impossible to predict exact settings. So set the scale two divisions above the required setting (two divisions above the $\frac{1}{2}$ " [12,7mm] setting in this example). This should result in oversize pins for the first test. (The narrow central panel ② is simply a reminder of the straight cutter diameter required for various pin widths.)

Chapter 8 D4 User Guide

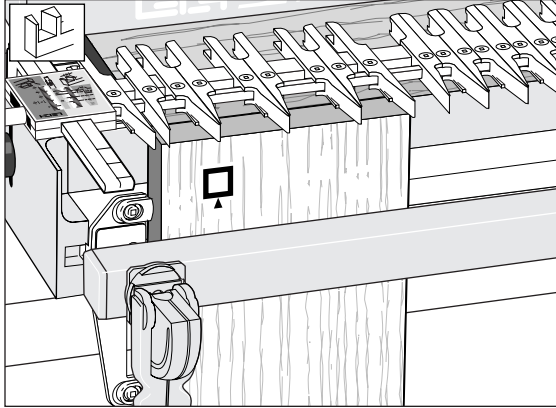
**8-27**

Clamp a test pin board against the left hand side stop, outside face \square away from the jig, with the top end flush under the guides.

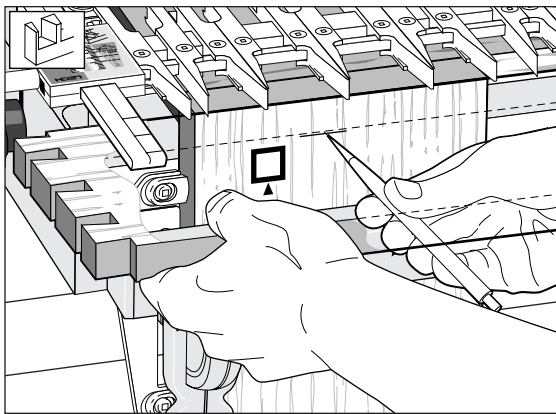
**8-28**

Place the side edge of one of the *tail boards* horizontally flush under the guidefingers and mark a thin pencil line part way across the pin board.

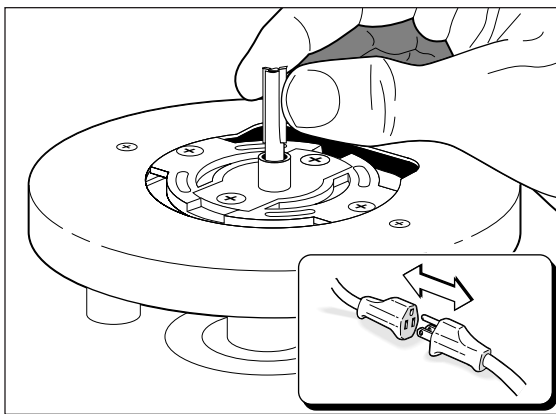
**8-29**

Unplug the router and remove the dovetail cutter. Mount the No. 140 or 140-8 straight cutter to the router.

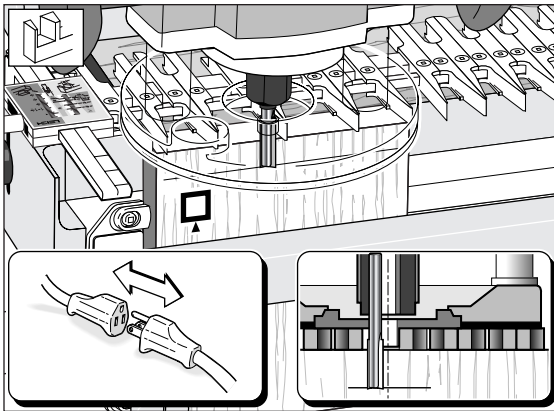
**8-30**

Place the router on the finger assembly and adjust the router until the cutter tip is level with the centre of the pencil line. Check to make sure the cutter rotates freely.

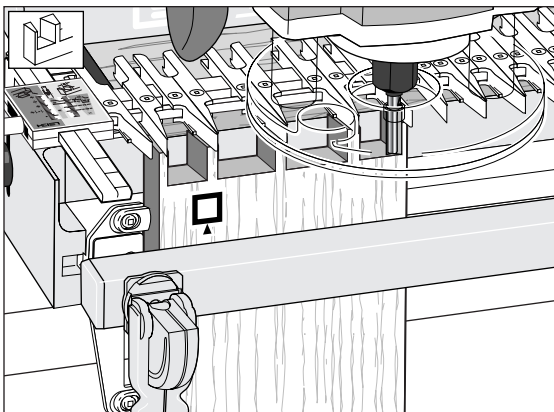
**8-31**

Rout out the waste between the pins. Check to make sure no parts have been missed. (See page 141 for hints and tips on how to minimize tearout.)

Use only light side pressure on the guide fingers.

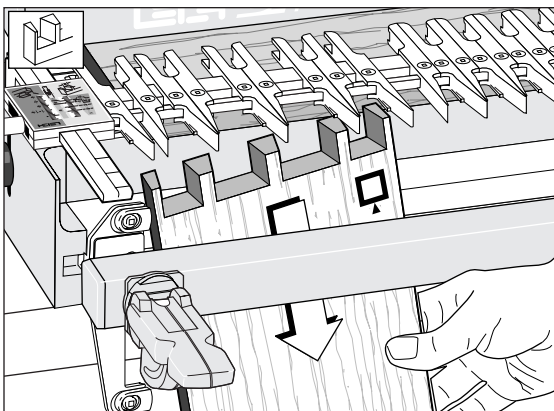
**8-32**

Remove the test pin board from the jig and test it for fit in one of the tail boards.

Chapter 8 D4 User Guide

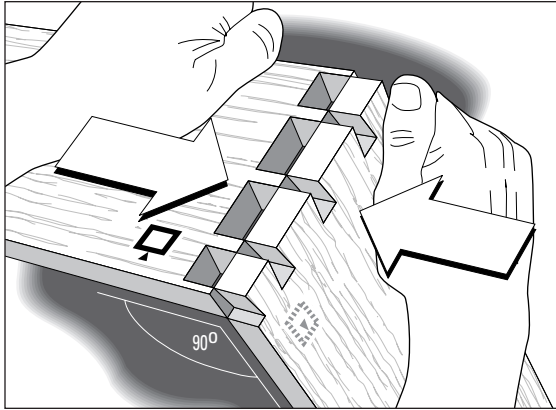
**8-33**

Make sure the outside faces \square face outward on both pieces. The joint will probably be too tight. A firm push fit is perfect, perhaps a tap with the heel of your hand. But having to use a mallet means the joint is too tight to take glue.

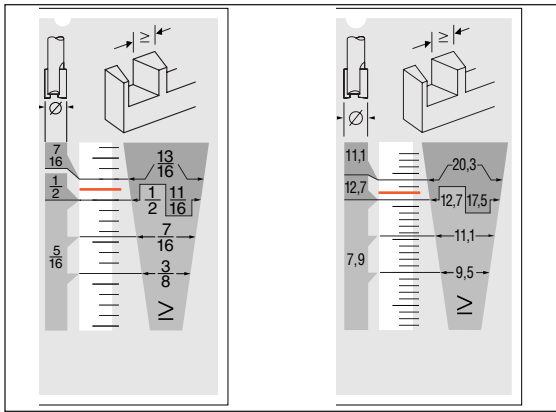
**8-34**

If it is much too tight, move the finger assembly in (away from you) by one division on the scale. If it is only a little tight, adjust the scale by only half a division.

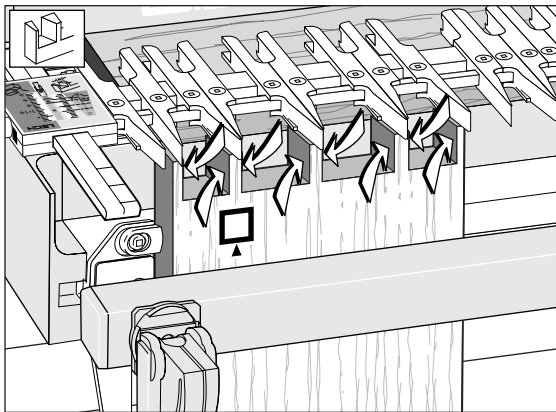
**8-35**

Replace the same pin board back in the jig, carefully aligned against the same side stop. Rout off the sides of the pins and test it again for fit.

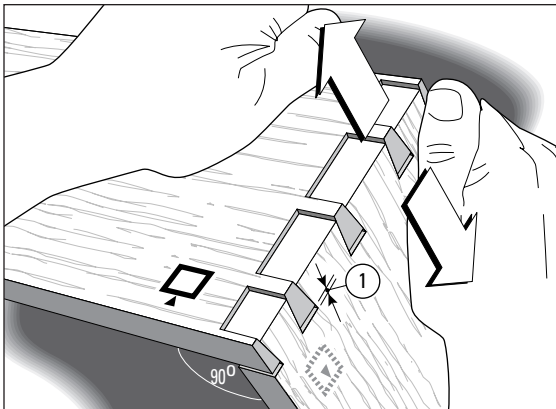
**8-36**

Test and repeat as required to achieve the desired fit.

Note: if you overdo it and make a loose joint, you need to move the finger assembly toward you by the same amount as the gap at the bottom of the pins ① (when the pins are pulled against the socket sides). Test again on the other end of this (fifth) board.

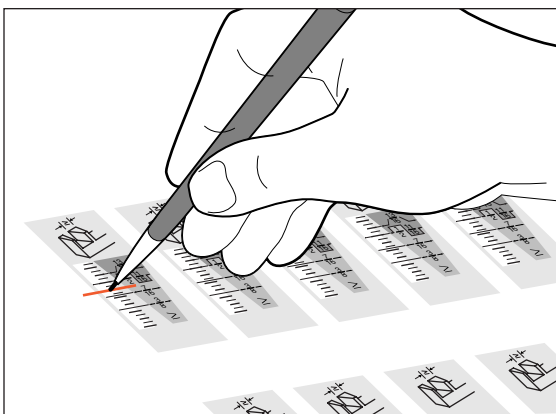
**8-37**

Once the correct fit is achieved, mark the final TD PINS scale setting on one of the scale prints on page 67 for future reference. Very slight variations to the scale setting may be necessary with different wood species or hardness.

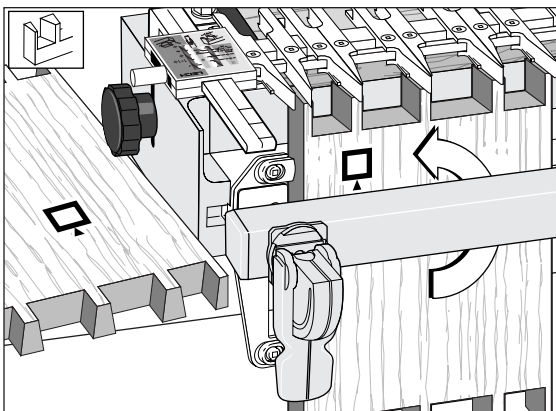
**8-38**

Route all four ends of the pin boards, keeping the outside face □ outwards. (With luck you may not have used the fifth board.)

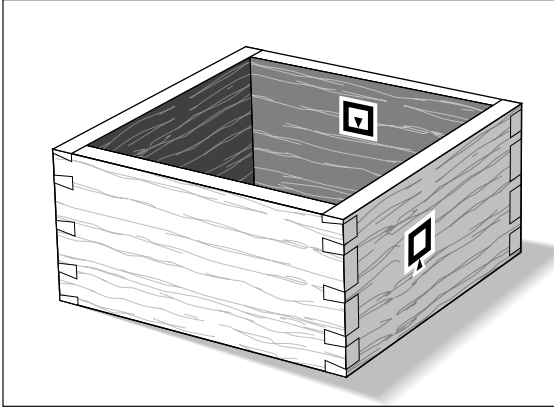
**8-39**

Assemble the box, making sure the tail boards face the proper way, inside faces in.

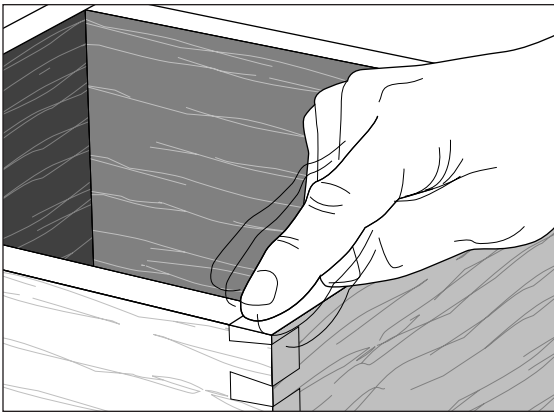
**8-40**

The box should be square and in plane. If it is not in plane (i.e., the side edges of each board are not in line), then either the ends of the boards are not square or the boards are not of equal widths.

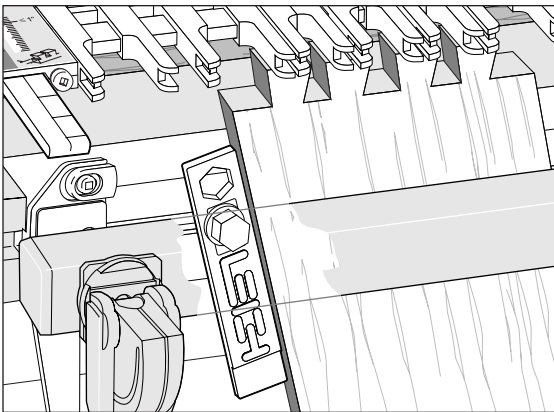
**8-41**

To form angled dovetails, refer to the Tips & Techniques bulletin “How to Rout Angled Through Dovetails on your Leigh Jig”, supplied with the jig. The Leigh wrench may help in this procedure. Attach it to the captive nut in the front extrusion using the hex bolt and washer provided.

Chapter 8 D4 User Guide

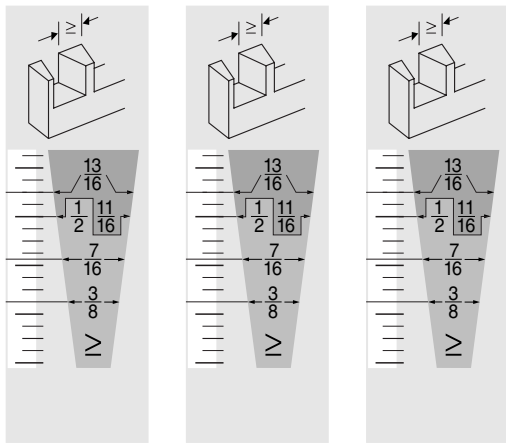
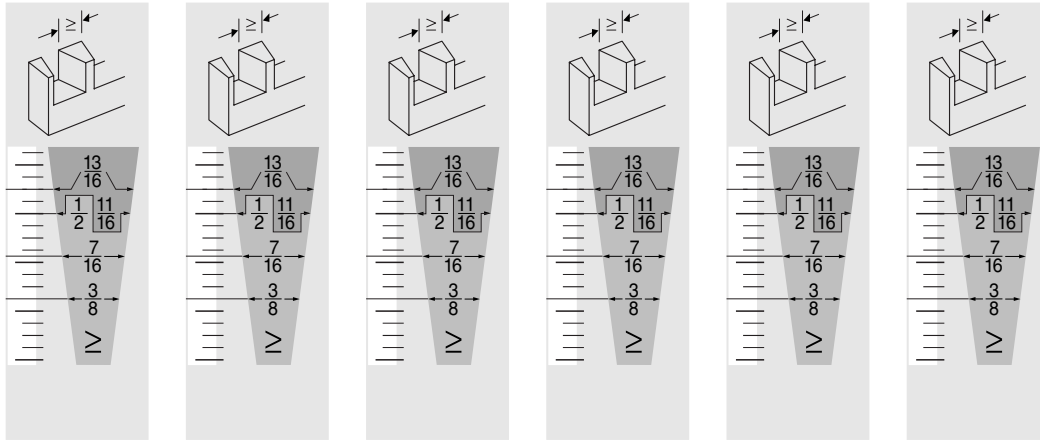

INCHES

MILLIMETRES

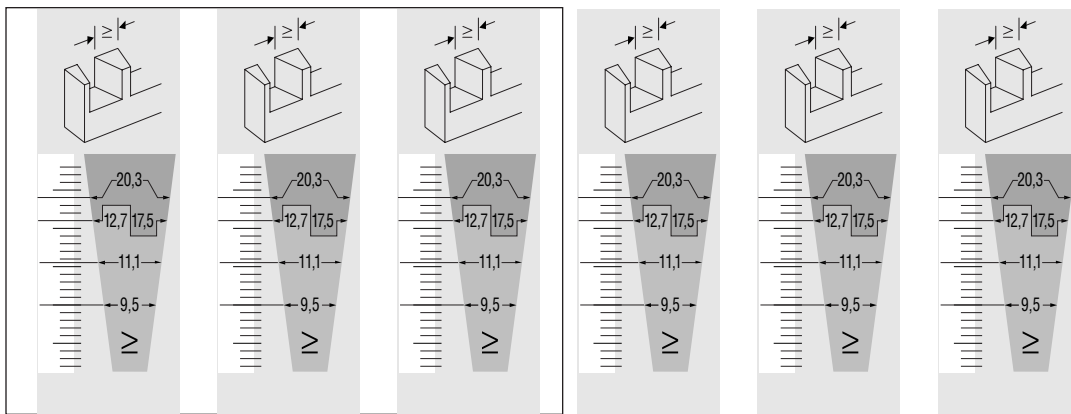
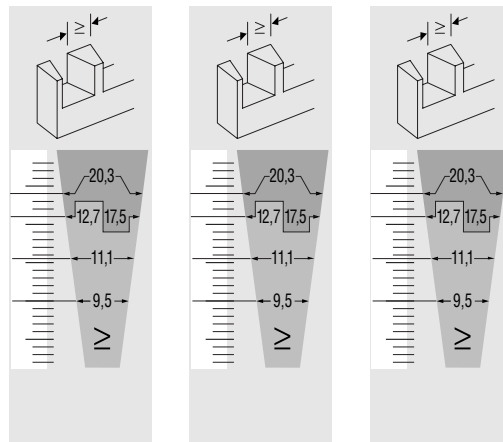

Large and Small Through Dovetails

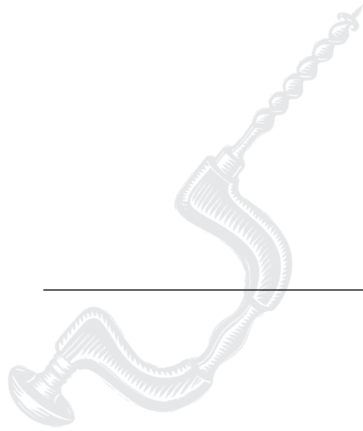

Chapter Foreword

The following procedures considerably expand the D4 jig's versatility. However, before attempting them, thoroughly master the techniques of Through Dovetails in Chapter 8.

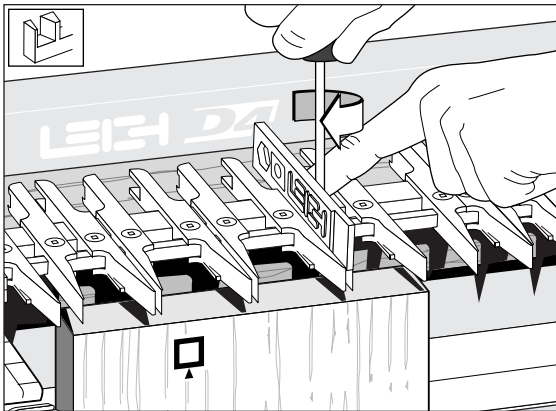

9-1 LARGE THROUGH DOVETAILS

The procedures for using cutters 90 and 160 or 100 and 150 are identical to the previous figures, except that a $\frac{5}{8}$ " [15,9mm] OD guidebush is used, and *each pair of guidefingers must be at least $\frac{3}{16}$ " [5mm] apart*. Use the Leigh wrench gauge ($\frac{3}{16}$ " [5mm] thick) to make sure there is enough separation. Note: Because the fingers are separated by $\frac{3}{16}$ " [5mm], the closest possible pin centres using these cutter combinations is $1\frac{3}{8}$ " [35mm], instead of 1" [25,4mm].

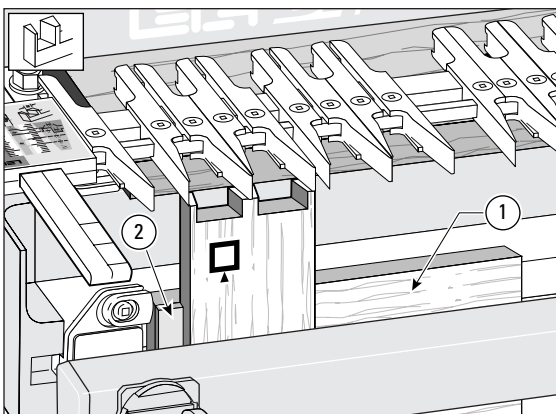

9-2 SMALL THROUGH DOVETAILS

Item 50 and 60 cutters allow you to create tiny through dovetails in material $\frac{3}{8}$ " [10mm] or less in thickness. This procedure is an extra bonus: the Leigh jig was not originally designed for it. The TD PINS scale does not go down far enough, so you have to space the boards away from the jig face with a shop-made block ① fitted with its own side stop ② (see next page for how to make the block). Use a $\frac{7}{16}$ " [11,1mm] O.D. guidebush for these small joints.

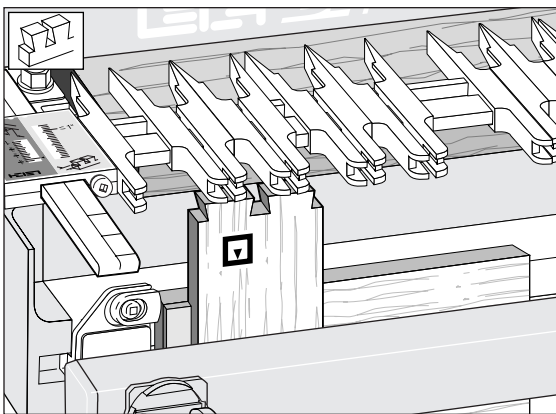

9-3

Use the same block with side stop when cutting the tails to ensure correct alignment of the pin and tail boards.

Chapter 9 D4 User Guide

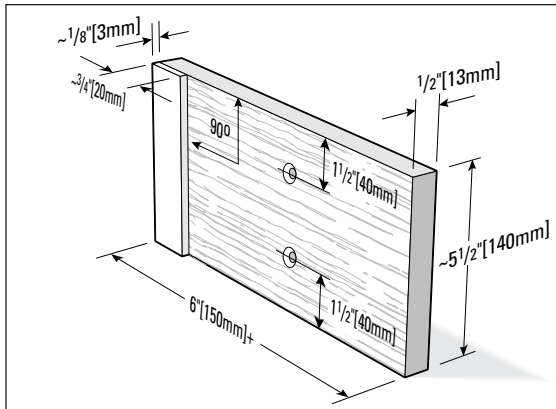
**9-4**

Make the block with side stop out of $\frac{1}{2}$ " [13mm] stock as shown. Bore two $\frac{1}{4}$ " [6mm] holes, countersunk for a flat head screw (part no. 287).

Or you could bore one hole and put side stop strips on both ends.

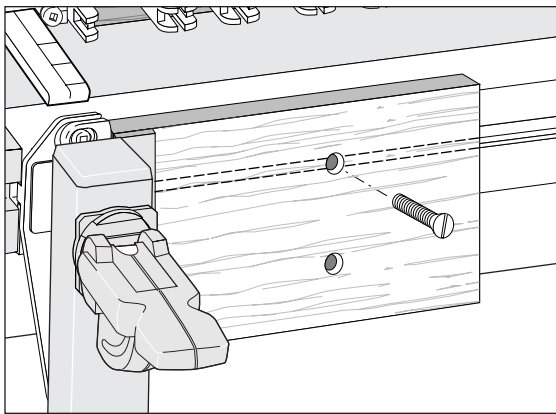
**9-5**

Remove one front cam clamp, lower the clamp bar and attach the block to the jig face using the screw (No. 287) into the entrapped square nut. Replace the clamp bar and cam clamp.

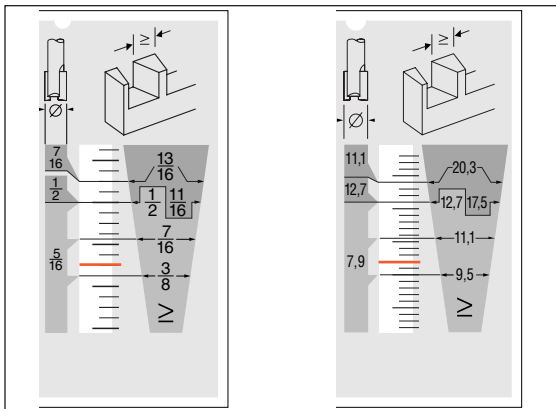
**9-6**

For boards up to $\frac{1}{4}$ " [6mm] thick use dovetail cutter 50 and pin cutter 140 with a $\frac{7}{16}$ " [11,1mm] guidebush. To cut pins matching the sockets made with item 50, begin with the setting shown here. Cut test pins in some scrap stock and test for fit. Adjust as necessary.

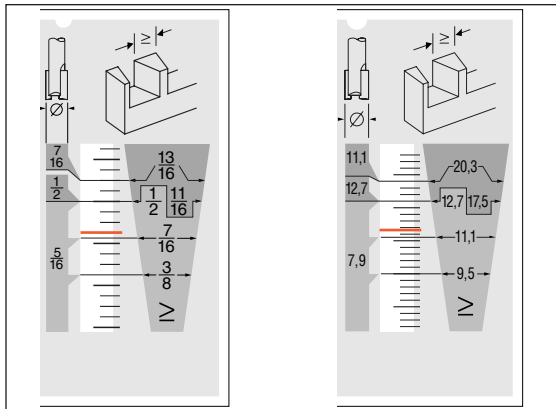

9-7

For boards up to $\frac{3}{8}$ " [9,5mm] thick use dovetail cutter 60 and pin cutter 140 with a $\frac{7}{16}$ " [11,1mm] guidebush. To cut pins matching the sockets made with item 60, begin with the setting shown here. Cut test pieces in some scrap stock and test for fit, then adjust as necessary. Record the actual settings for cutters 50 and 60 on these scale reproductions below.

Note: You may also rout joints in boards $\frac{5}{16}$ " to $\frac{3}{8}$ " [8,0 to 9,5mm] with cutters No. 70 and 140 without the use of the shop-made block.

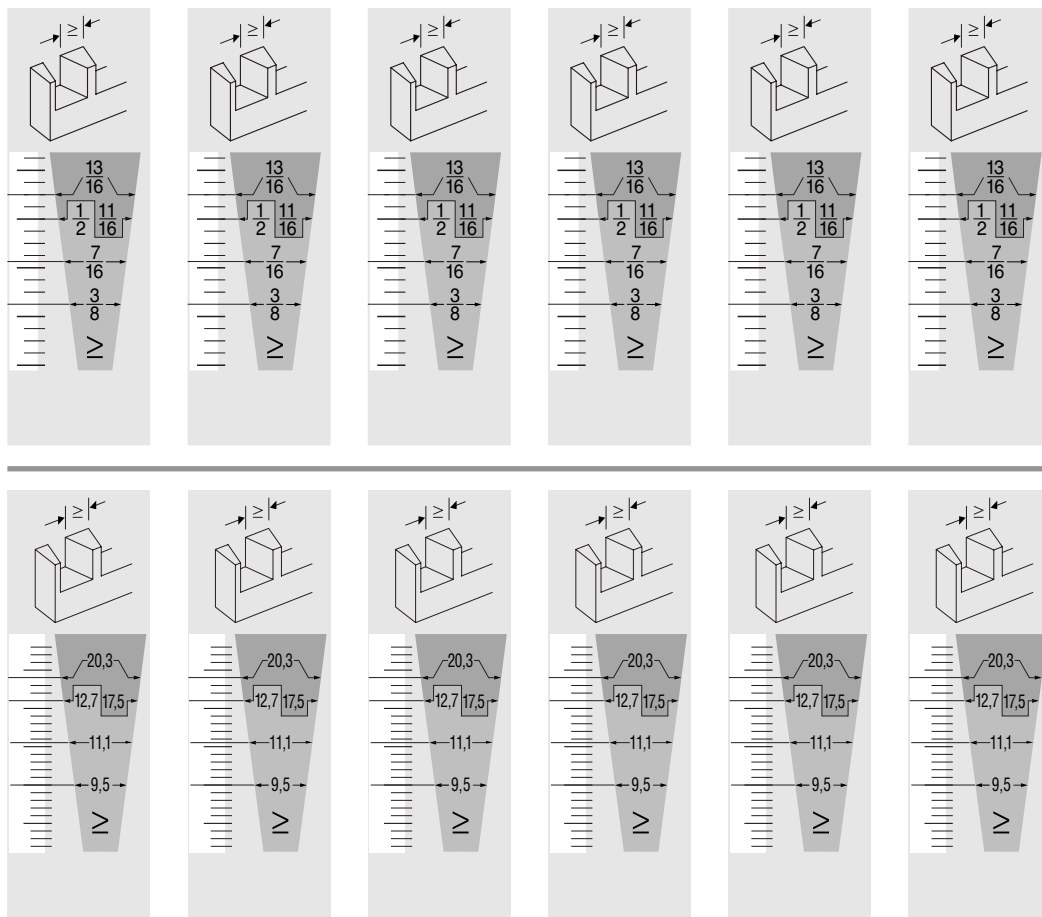

Half-Blind Dovetail Procedures



Chapter Foreword

In these instructions for using the Leigh Dovetail Jig, we have recommended using certain cutters and board sizes just because they are easy to work with. When you have cut some practice joints and gained confidence in your ability to get the results you want, use the half-blind cutter selection chart on page 160 to plan the dovetail routing you need for your own projects.

Note: Only the $\frac{7}{16}$ " OD guidebushes and the four cutters listed opposite may be used for half-blind dovetails. See "Half Blind Cutter Selection" on page 160 for a full description on how to select the appropriate cutter.

IMPORTANT!

The most misunderstood aspect of routing half-blind dovetails is how the cutter angle affects the Depth of Cut setting. Theoretically, there is only one "perfect" depth of cut for a given cutter that will produce properly mating Pins and Sockets. Therefore, raising or lowering the cutter during test cuts is done only to achieve that one "perfect depth" that is determined by angle of the selected cutter. Any other depth will produce a joint that is too loose or too tight.

Please read this carefully and note the specified Depth of Cut for the different cutter angles shown.

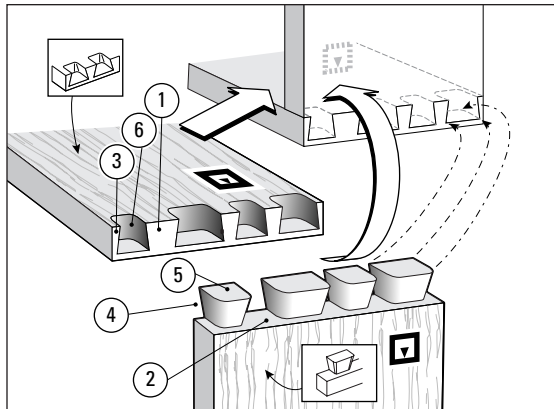
**10-1**

Half-blind Dovetails:

- ① Pins
- ② Pin sockets
- ③ Half-pins
- ④ Half-pin sockets
- ⑤ Tails
- ⑥ Tail Sockets

The pins fit in the pin sockets. Joints almost always end each side with half-pins.

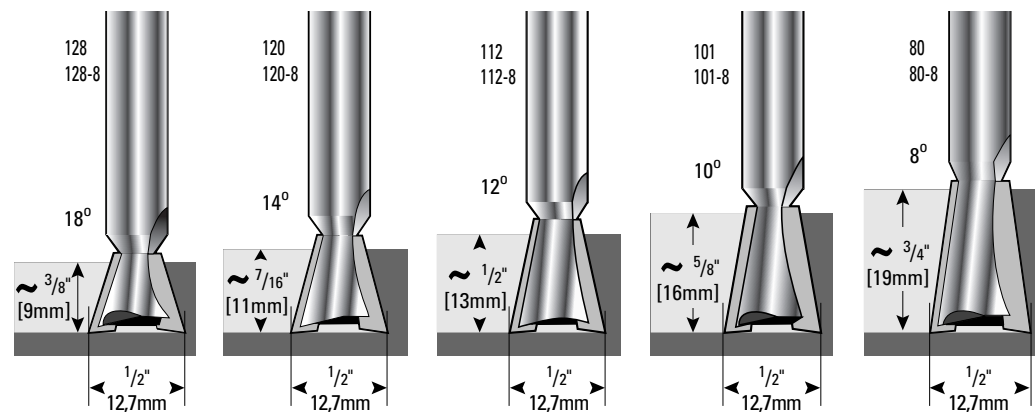

10-2 Important! Read This About Depth of Cut.

- Depth of cut must be as specified when using any of the four cutters illustrated above.
- Raising the cutter above its specified cutting depth will result in loose joints and may damage the jig, cutter and/or guidebush. A lower setting will result in tighter joints that may not fit together.
- Minor Depth of Cut adjustment will change the tightness of joint fit. See 10-14 to 10-16 to find out why.
- Half-blind PINS and TAILS are routed with the same dovetail cutter and must be at the same Depth of Cut.
- Choose one of the four 1/2" [12,7 mm] diameter dovetail cutters shown above, and check cutter selection on page 160.
- Use only 7/16" [11,1 mm] outside diameter guidebushes.

Chapter 10 D4 User Guide

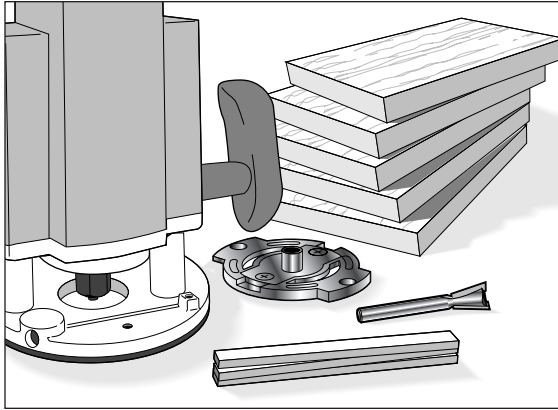
**10-3**

Let's cut a single test joint. You will need one router, a $\frac{7}{16}$ " [11,1mm] guidebush, either a No.120- $\frac{1}{2}$ " [12,7mm] 14° dovetail cutter or a No.101- $\frac{1}{2}$ " [12,7mm] 10° dovetail cutter or the 8mm shank equivalent. **The 80 series cutters cut too deep for $\frac{3}{4}$ " [20mm] boards** (see the HB cutter selection charts on page 161). You will also need several pieces of $\frac{3}{4}$ " x $5\frac{1}{2}$ " [20x140mm] x 8" [200mm] or so long, *and some $\frac{1}{4}$ " [6,35mm] x $\frac{1}{2}$ " [12,7mm] hardwood strip for bridge pieces.*

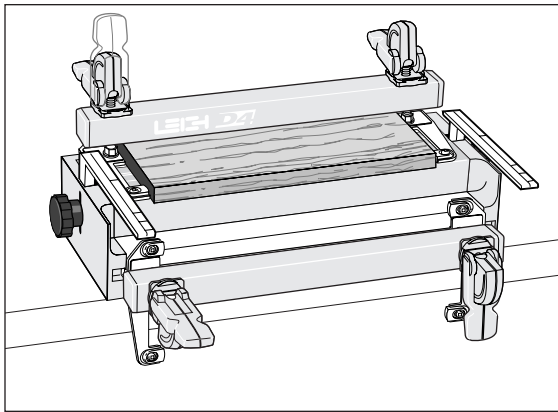
**10-4**

Clamp the spacer board in the rear clamp.

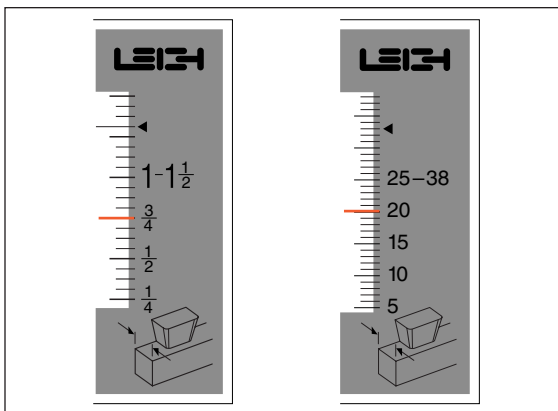
**10-5**

Mount the finger assembly on the support brackets in the  HB TAILS mode, flat on the spacer board, *scales set on the thickness of the tail board ($\frac{3}{4}$ " [20mm] in this instance).*

The  HB TAILS scale is always set at the tail board thickness.

(The scale increments above 1-1 $\frac{1}{2}$ " [25-38mm] are for use on sliding dovetails - see chapter 14.)

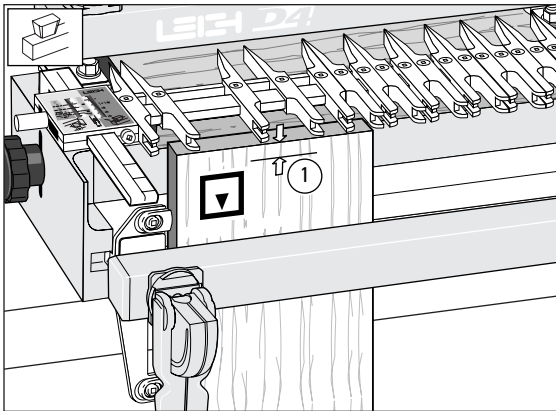
**10-6**

Measure and mark a line on the inside face of the tail board ① to the working depth of the cutter to be used as per 10-2 this chapter. Clamp this test tail board in the left front clamp, against the side stop with the top edge flush under the guidefingers, and the inside face \square of the drawer side away from the jig.

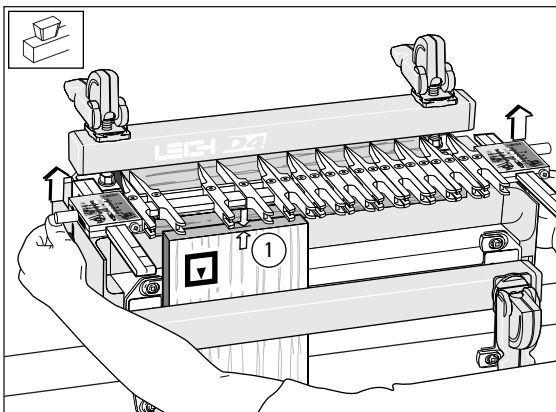
**10-7**

Unlock and raise the finger assembly support brackets slightly so that the finger assembly is about $\frac{1}{16}$ " [2mm] ① above the boards. This will allow easy movement of the guidefingers.

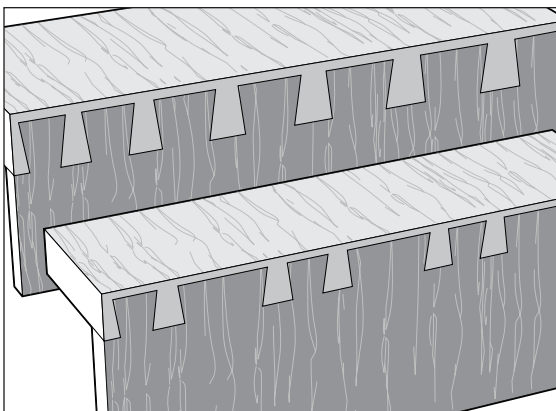
**10-8**

The following joint design is only a suggestion for this trial. It has a typical and traditional even layout of pins, with half-pins at each edge. The Leigh jig, however, allows for an infinite variety of joint designs, and boards of different thicknesses can be joined to each other as shown in this illustration. Before attempting joints of asymmetrical design, please see chapter 13.

Chapter 10 D4 User Guide

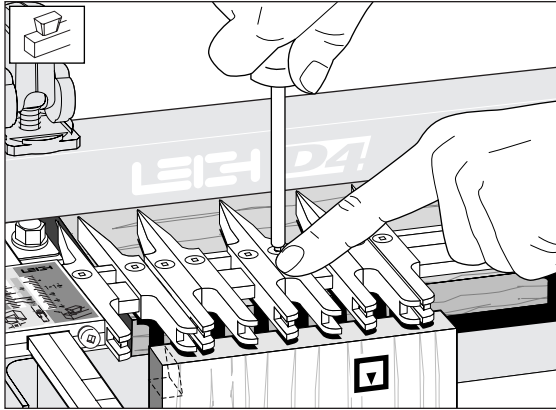
**10-9**

Ignoring the extreme outer guidefinger next to the scale (which just supports the router), loosen enough of the adjacent guides to give the required tail layout. The half-pin guidefinger position illustrated will give a half-pin socket profile like that shown (dotted lines).

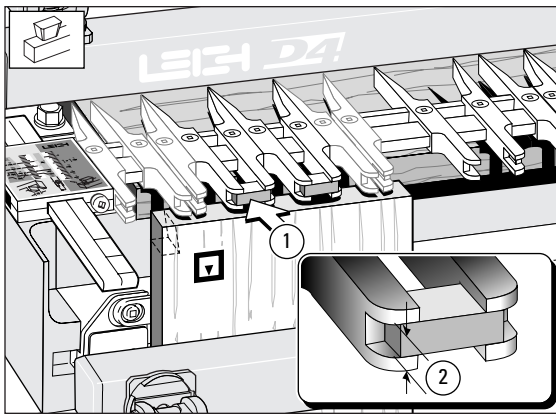
**10-10**

If the gaps between the guidefinger tails are wider than about $\frac{1}{8}$ " [3mm], mark off and cut some pieces of hardwood bridge strip ① to fit into the slots in the ends of the guidefinger tails. *Make sure the $\frac{1}{4}$ " [6,35mm] dimension ② on the strip is snug*, so the bridge pieces will not fall out. Be sure to make them slightly shorter than the distance between the guidefinger shoulders, so the guidefingers will not be forced apart when you put in the bridge pieces.

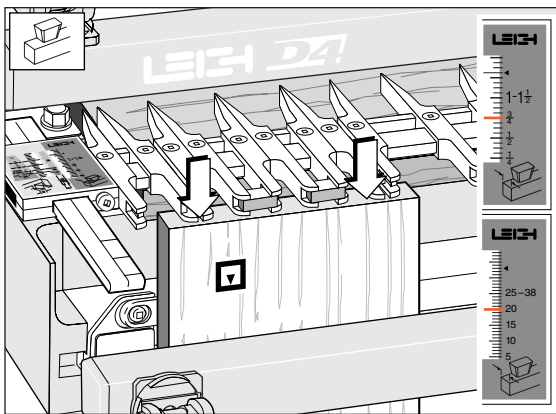
**10-11**

Remember to tighten any loose guidefingers. Lower the finger assembly back onto the spacer board and workpiece. **It must touch the workpiece or the depth of cut will vary and the joint won't fit.** The scale should be set on the tailboard thickness, in this case $\frac{3}{4}$ " [20mm].

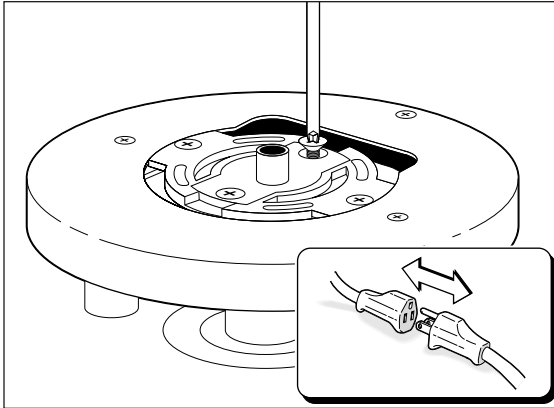

10-12
Attach the $\frac{7}{16}$ " [11,1mm] guidebush to the router securely.

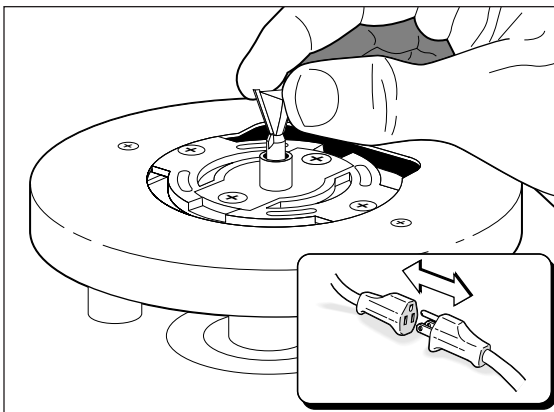

10-13
Mount either the No.120 or No.101 (or the 8mm shank equivalent) cutter to the router.

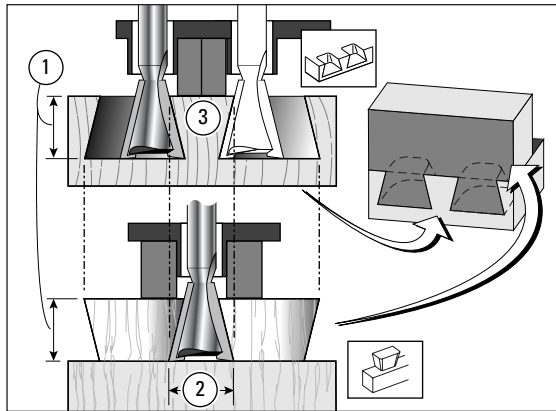
**10-14 Adjusting Joint Tightness**

Here's why the depth of cut ① changes the fit in half-blind dovetails. Increasing or decreasing the depth of cut does not affect the pin socket width ②, but does affect the width of the pin ③ that goes into the socket ②.

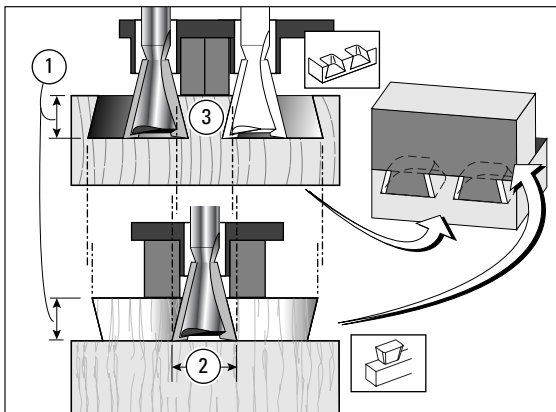
**10-15**

Note that decreasing the cutter depth ① makes the pin ③ narrower while the pin socket ② stays the same width, producing a loose fit.

Decreasing the cutter depth (i.e. raise the cutter into the router) produces a looser fit.

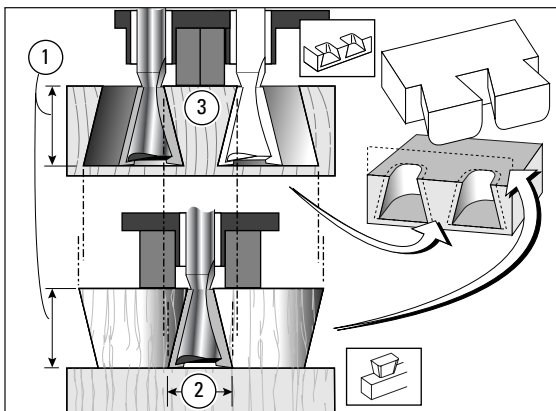
**10-16**

Increasing the cutter depth ① makes the pin ③ larger while the pin socket ② stays the same width, producing too tight a fit.

Increasing the cutter depth (i.e. lower the cutter) produces a tighter fit.

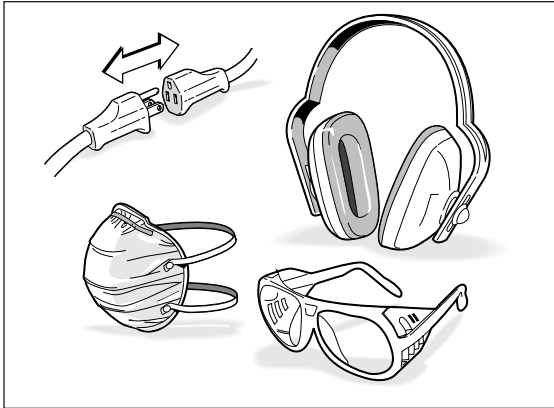

10-17
Remember to follow all safety precautions when routing.

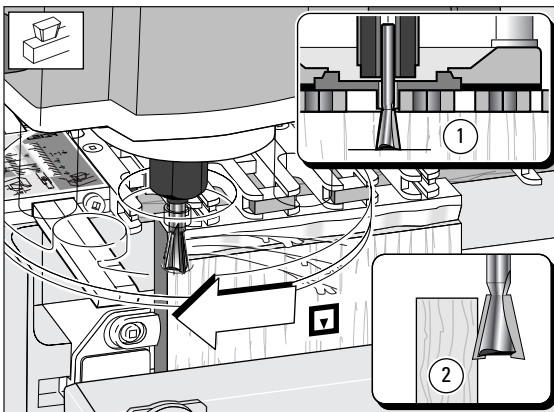

10-18 
Adjust the cutter height until the cutter tip is level with the marked line ①. For the first light cut move the router from right to left. Make sure you control it firmly, because it is driven in this direction by the cutter. Only the tip of the cutter should be cutting on the first cut ②. This *back* or *climb* routing leaves a very clean shoulder in side grain.

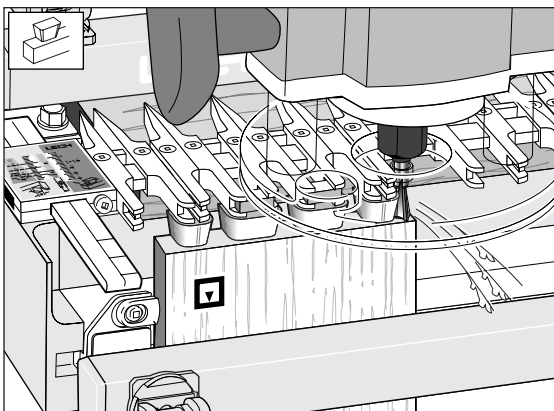

10-19
Now rout in and out from left to right following the guides and bridge pieces to rout out the pin sockets, leaving the tails.

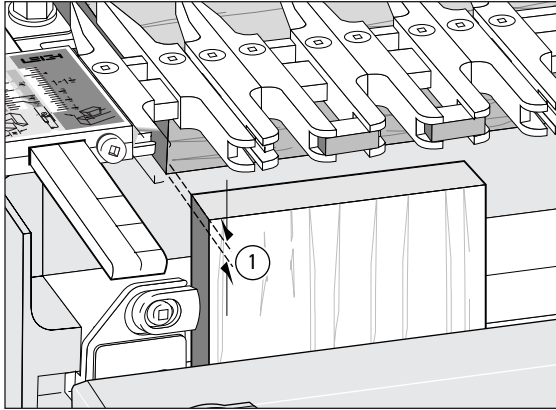
**10-20**

Remove the test tail board, then clamp a scrap board in the front of the jig so that the top edge projects above the top face of the jig by about $\frac{1}{8}$ " [3mm] ①. This will keep the scrap piece below the path of the cutter when routing the pin board.

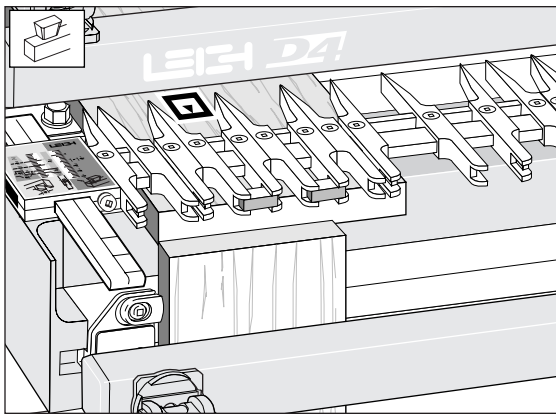
**10-21**

Remove the spacer board from the rear clamp. Place a test pin board in the left rear clamp against the side stop, fitting its front end edge flush against the vertical scrap piece, with the inside face of the drawer front away from the jig body. The pin board is now positioned with the edge to be routed flush with the jig's front face, correctly registered for the scale readings.

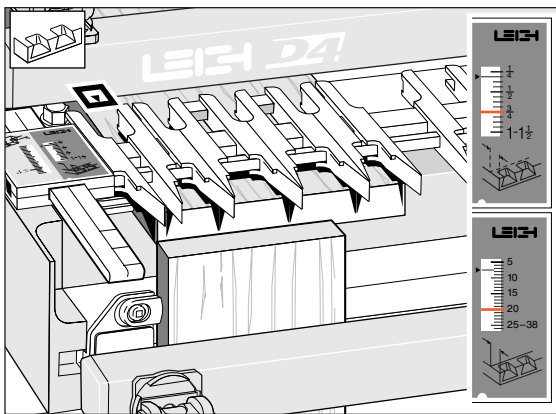
**10-22**

Rotate the finger assembly to the  HB PINS mode and set the HB PINS scale equal to the tail board thickness (i.e., the same setting as for the tails: in this example, $\frac{3}{4}$ " [20mm]).

Both HB pins and HB tail scales are always set to the tail board thickness.

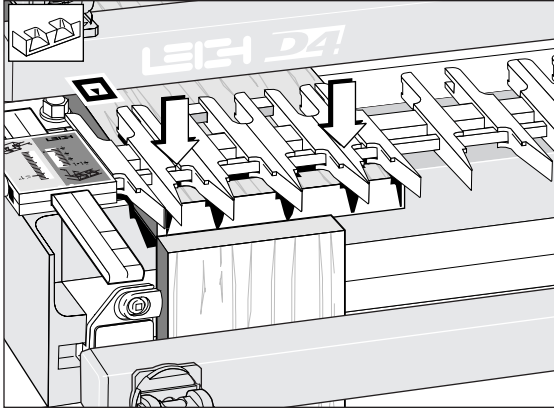
**10-23**

Make sure the finger assembly is flush and level on top of the pin board.

The guidefingers must be touching the pin boards or the depth of cut will vary and cause poor joint fit.

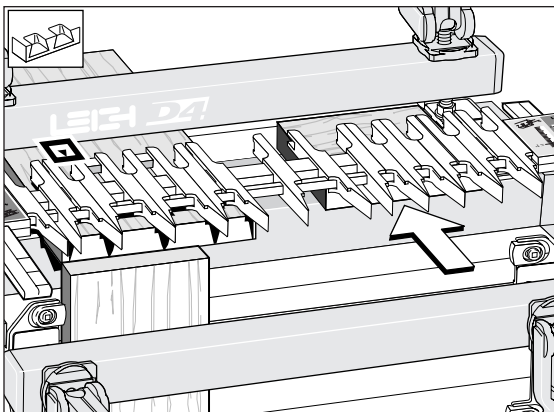
**10-24**

If you have difficulty leveling the finger assembly on a narrow workpiece, place a board the same thickness as the pin board under the other end of the finger assembly, *but not in the rear clamp*.

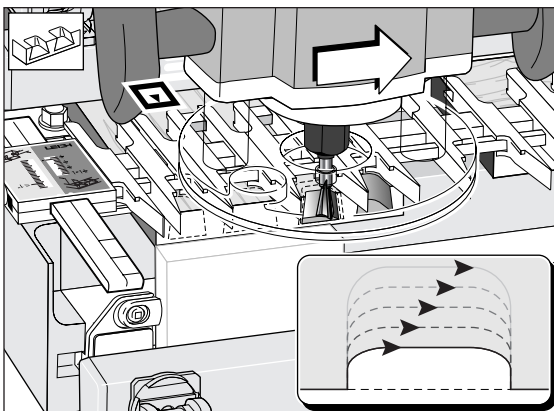
**10-25**

Rout out the waste between the pins. Rout each space from left to right. Do not back rout on end grain. If the cutter enters on the right side of the opening there will be a very strong pull to the left, so...

Chapter 10 D4 User Guide

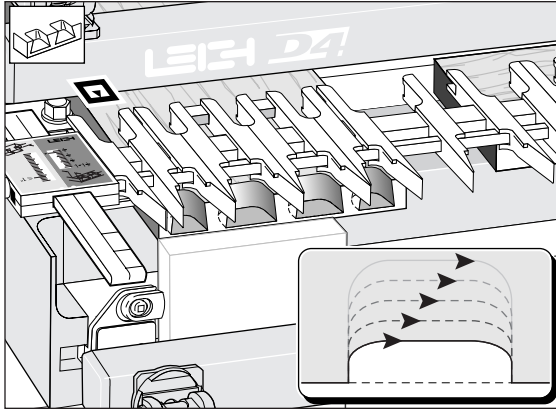
**10-26**

Rout each opening in at least three or four passes, **left to right**.

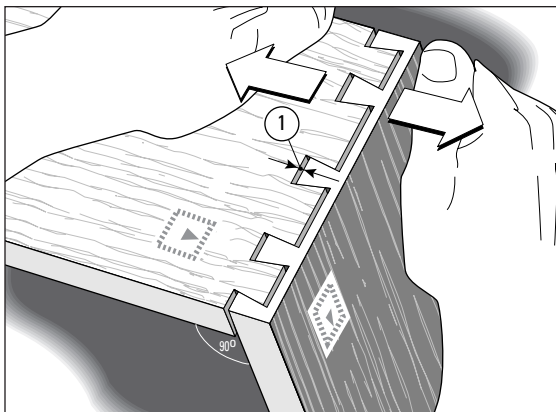
**10-27**

Remove the pin board and test the joint for fit. If the joint is loose, as shown here, you need to lower the cutter by the same amount as the gap at the bottom of the pins ① (when the pins are pulled against the socket sides). If the joint is too tight, raise the cutter slightly. Test again. You cannot rout the same board twice with a dovetail cutter, so use two fresh board ends for each test.

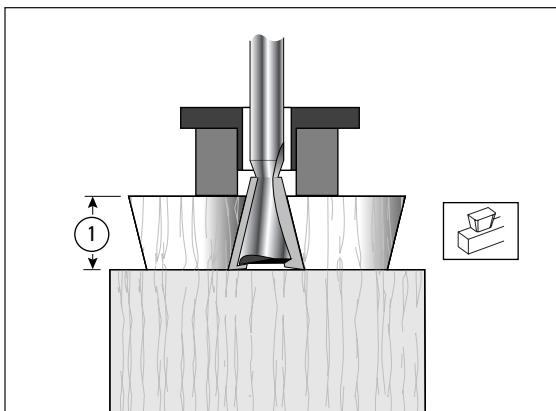
**10-28**

Keep the test tail board that fits well, and mark it with the number of the cutter you used to rout it. For quick set-up next time, clamp this tail board in the jig as a *depth-of-cut gauge* ① to show how far to lower the cutter.

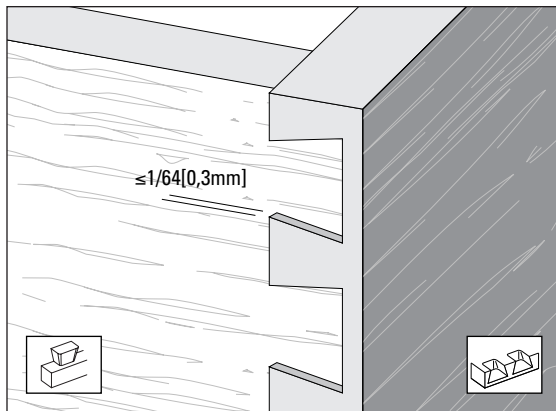
**10-29**

When you have the proper tightness of fit, check the flushness. The tails should be under flush to the pins by *no more than* $\frac{1}{64}$ [0,3mm] to allow for cleanup. The concentricity of the collet and guidebush on different routers will affect this tolerance.

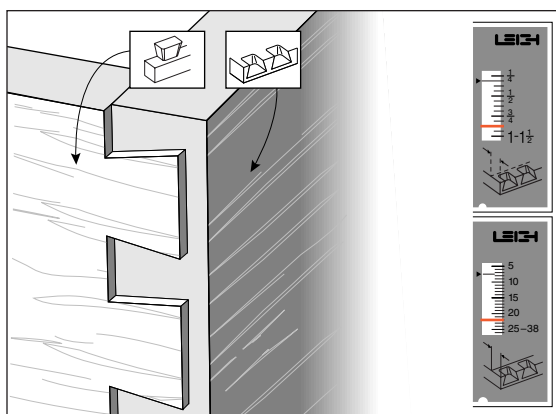
**10-30**

If the tails stand out from the pins, set the HB PINS scale **away from the operator** by the amount required.

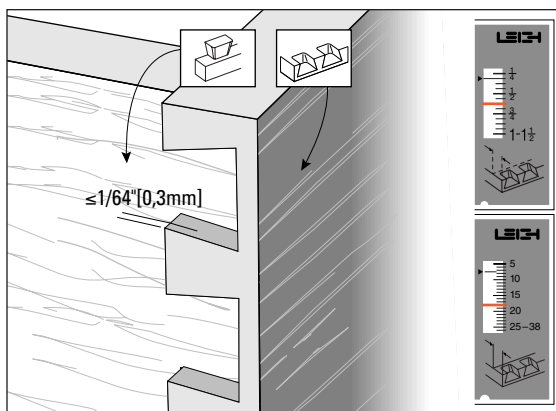
**10-31**

If the tails fit in too far past the pins ends, set the HB PINS scale **toward the operator** by the amount required. These adjustments for “flushness” are made only in the HB PINS mode.

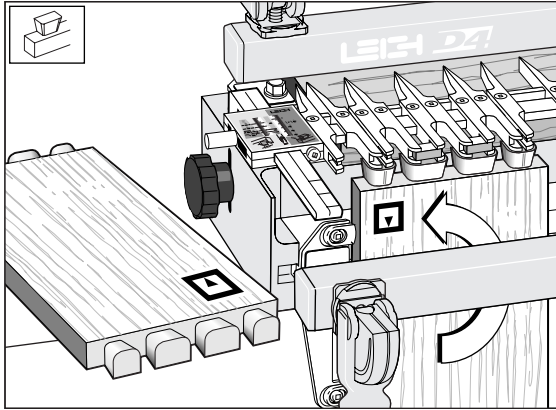
**10-32**

To make a box, rout all four ends of the tail boards, keeping the inside face ▣ of the tail boards away from the jig.

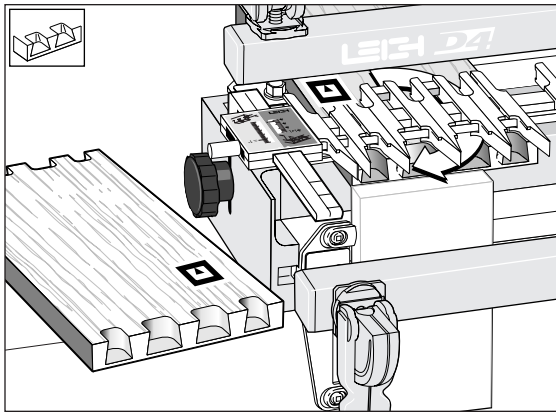
**10-33**

Rout all four ends of the pin boards keeping the inside face ▣ of the boards away from the jig.

Note: When making drawers you may prefer to use through dovetails on the rear corners.

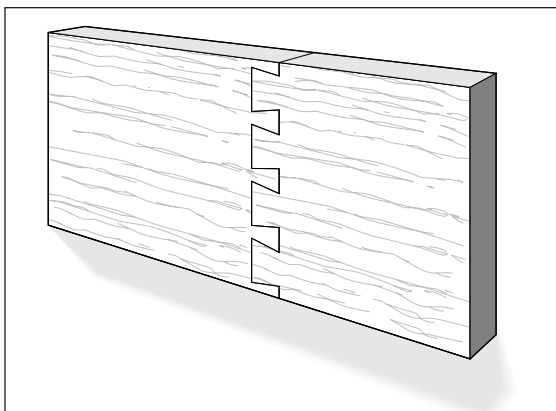
**10-34 End-on-End Dovetails**

While you have the router set up and the cut depth correctly adjusted for half-blind dovetails, it is a good time to try end-on-end dovetails. These are made in the same modes as half-blind joints, but the boards are both routed vertically in the front clamp. End-on-end joints may be up to $\frac{3}{4}$ " [20mm] thick. (See page 95 for end-on-end dovetail procedures.)

Rabbetted Half-Blind Dovetails



Chapter Foreword

Before attempting rabbetted half-blind dovetails, first master the techniques of flush half-blind dovetails in the previous chapter.

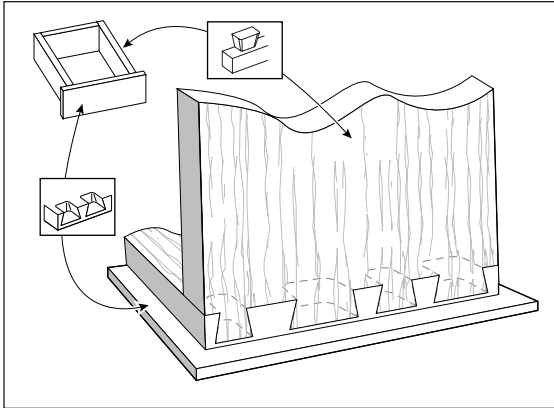
**11-1**

Mount and rout rabbeted drawer fronts and sides exactly the same way as flush drawer fronts, except...

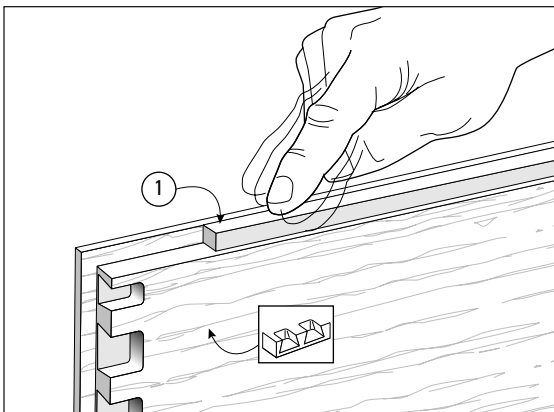
**11-2**

The drawer side must be blocked away from the front side stop by exactly the depth of the rabbet. So make up a block ① and...

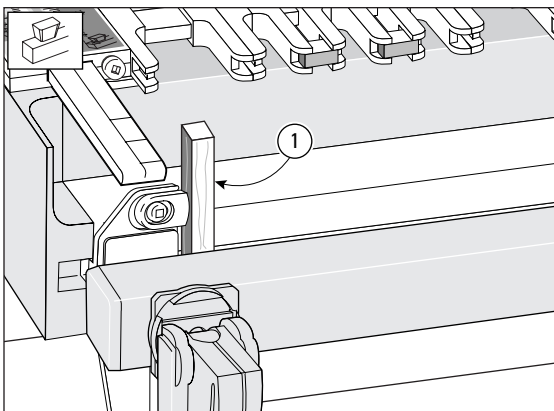
**11-3**

Stick the block ① to the jig face with double-sided tape, making sure it touches the side stop.

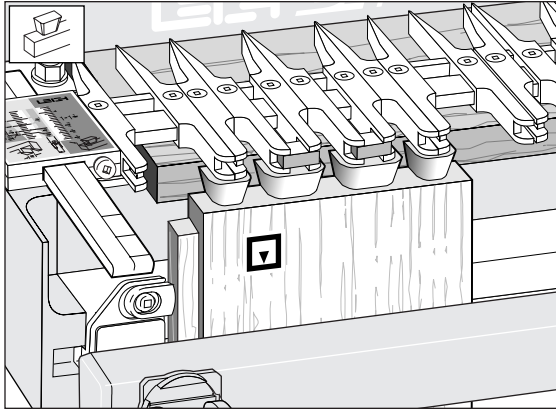
**11-4**

The drawer side will now be stepped in from the side stop by the width of the rabbett, bringing the sockets in line with the pins.

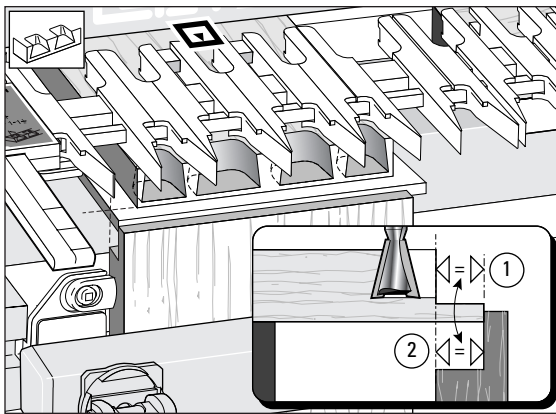
**11-5 Rabbetted Pins**

Block the scrap stop in the front of the jig out from the jig's front face by exactly the depth of the rabbett ①. This brings the pin ends exactly in line with the front jig face ②, ensuring that the scale reading is accurate.

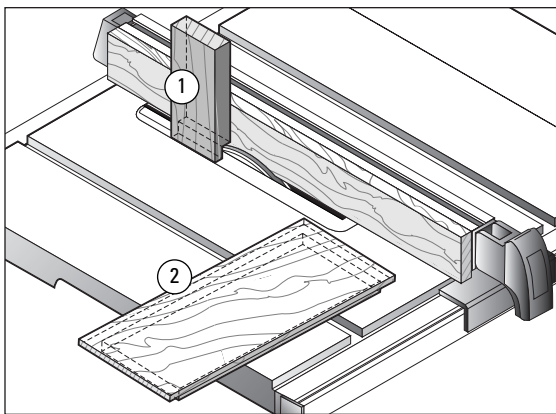
**11-6**

An easy accurate way to do this is to rabbett the end of the scrap piece ① vertically over the dado blade at the same time as you rabbett the drawer front (horizontally) ②.

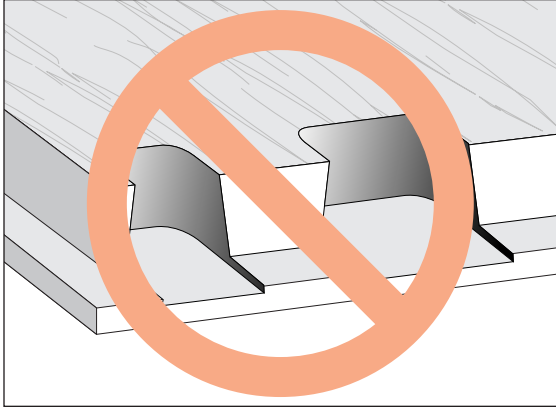
**11-7**

Make sure you select a dovetail cutter that has a working depth of cut less than the rabbet height. Otherwise, you will rout into the rabbet.

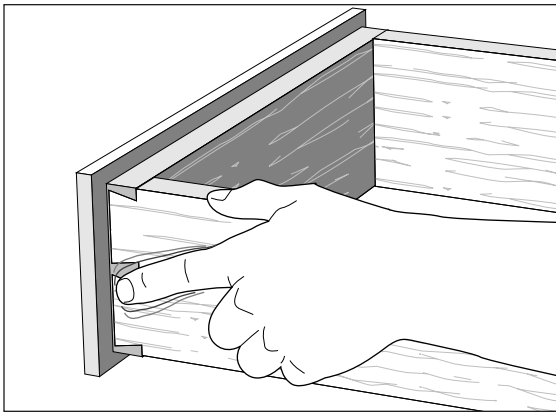
**11-8**

It is difficult to clean up the drawer sides and front corner after assembling a rabbeted drawer, so make sure the fit is flush before you complete the drawers. See 10-29 to 10-31.

End-On-End Dovetails

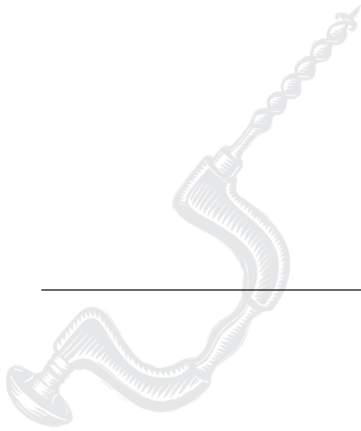

Chapter Foreword

While you have the router set up for half-blind dovetails, it is a good time to try end-on-end dovetails.

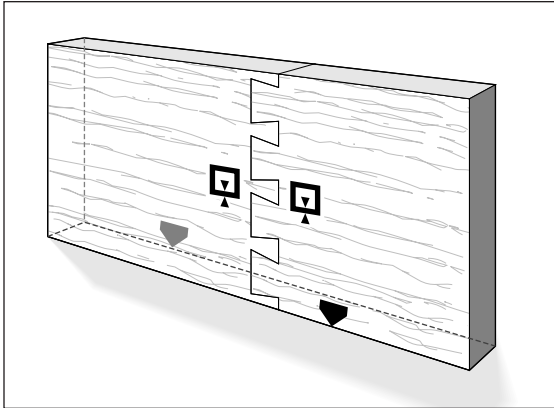

If you have not yet routed half-blind dovetails or read through chapter 10, please do so now before attempting end-on-end dovetails.

**12-1**

End-on-end dovetails are made in the same modes as half-blind joints, *but both boards are routed vertically in the front clamp*, alternately face side in and then face side out □. Boards for end-on-end joints may be up to 3/4" [20mm] thick.

 Use only the guidebush, dovetail cutters and depths of cut as specified in 10-2 on page 77.

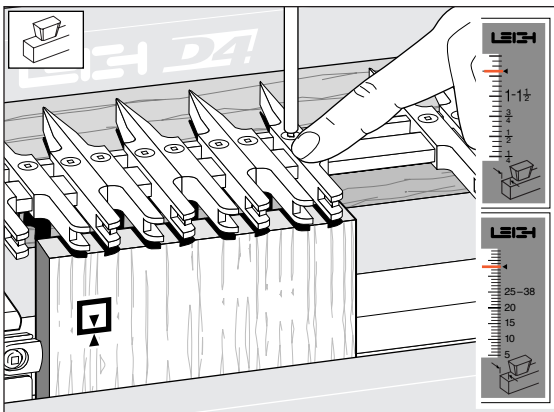
**12-2**

The end-on-end dovetail is laid out in the HB TAILS mode. There is a special mark on the scale for end-on-end dovetails. *Align the support bracket line with the small arrow as shown.* Adjust the guidefingers as required.

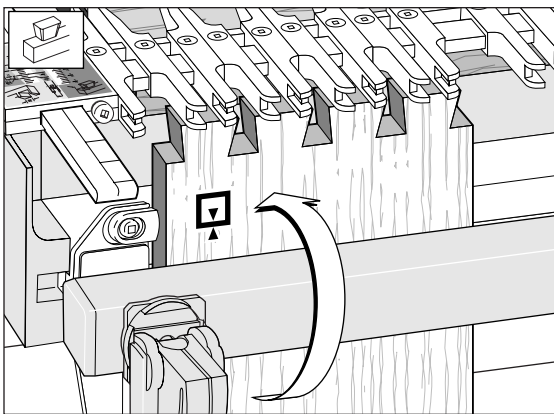
**12-3**

Rout the tails. Clamp end-on-end dovetail boards in the jig for routing one end face side in and one end face side out. *Keep the same edge against the side stop for both ends.*

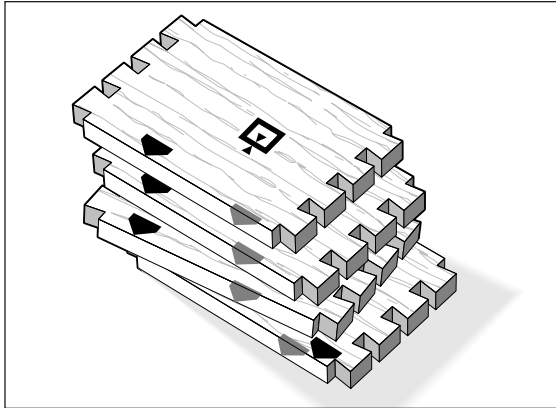
**12-4**

Rout the tails on each end of the tail boards.

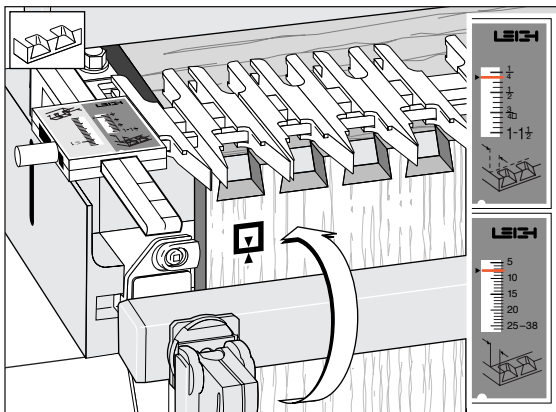
**12-5**

Rotate the finger assembly to the  HB PINS mode and again set it on the **small scale arrow**. This setting will give maximum pin thickness ($\frac{3}{4}$ " [20mm]). Rout the pins on each end of the pin boards. Keep the same edge against the sidestop for both ends.

Note: The illustration shows narrow pins (now looking like narrow tails), but remember the guidefingers can easily be adjusted to produce even-sized tails and pins if you prefer.

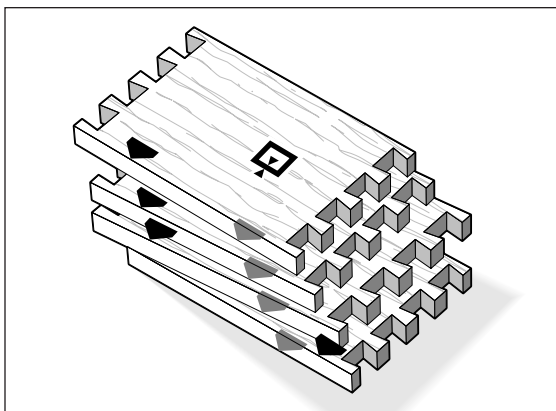
**12-6**

Always assemble end-on-end joints keeping the edges of the boards that were against the side stop all in line.

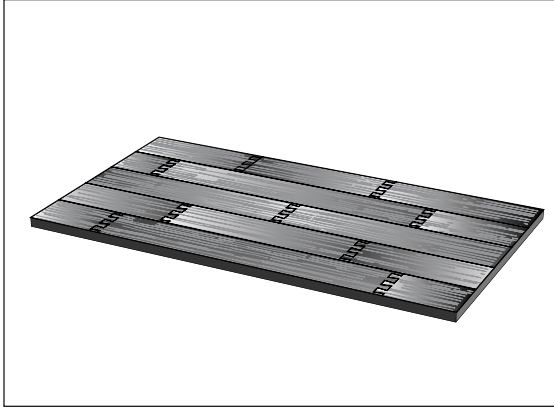

12-7 Applications for End-on-End Dovetails

As one example, you can make a flat, stable, and attractive chest lid by edge-jointing end-on-end dovetailed boards.

Asymmetric Dovetails

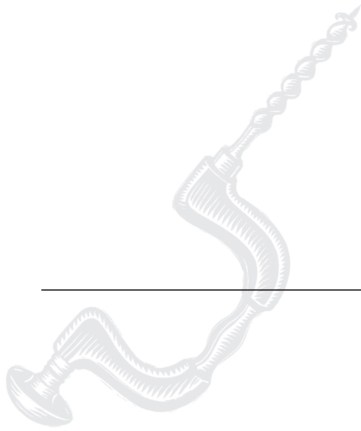

Chapter Foreword

For certain procedures, you will need to use both ends of the Leigh jig. Asymmetrical joint layouts are one example. On the Leigh Jig, no joints will be truly symmetrical, but they can *look* symmetrical. Apparent symmetry is only required for aesthetic reasons, and not for strength. **Be sure you have read and understood chapters 8 through 11 before attempting these procedures.**

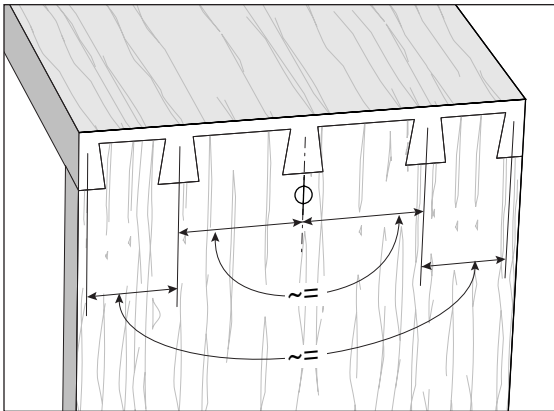
**13-1**

By *symmetrical* we mean a joint that looks or is approximately symmetrical about its centre line but is probably not, and need not be, precisely symmetrical. Using the Leigh jig, it is easy to cut a joint that looks symmetrical; the pins will always align perfectly with the tails cut at the same spacing. Remember, symmetry is only required for appearance, not for joinery reasons.

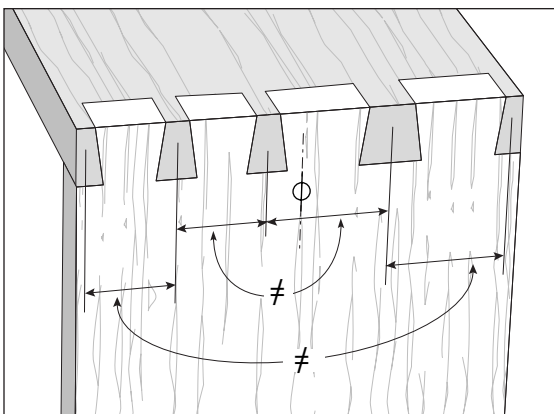
**13-2**

By *asymmetrical* we mean a deliberately uneven layout of pins and tails required by the project design.

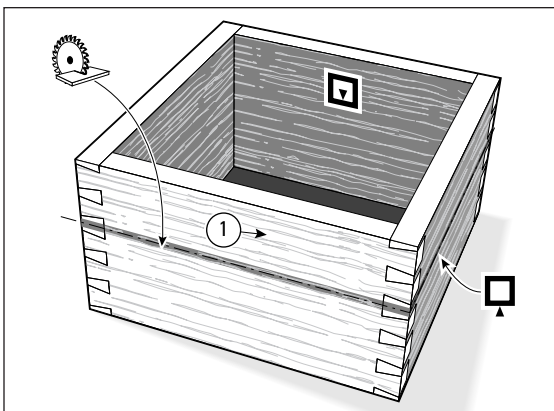
**13-3**

For example, asymmetrical joints may be used for blanket chests or boxes. One pin is made wider for a saw-cut allowance, so the half-pins all look the same width after the lid portion ① is cut off.

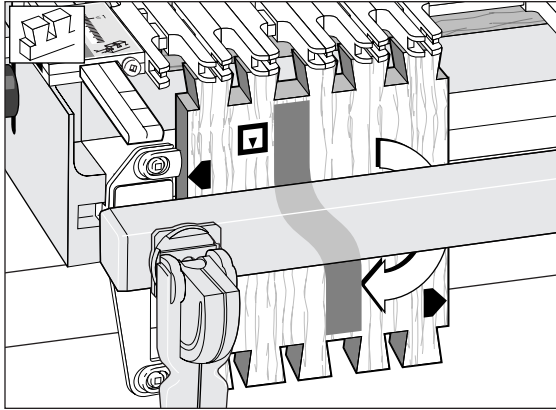
**13-4**

In the chest example you can see that if both ends of the board are cut under the same guidefingers, the wide sockets and pins at opposite ends will not line up. Remember, the same inside face \square of the through dovetail tail board has to face away from the jig for each cut.

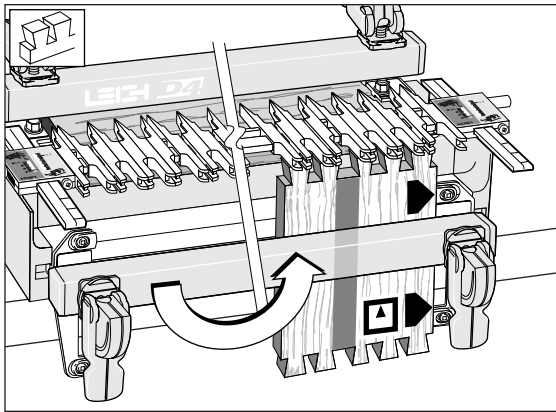

**13-5**

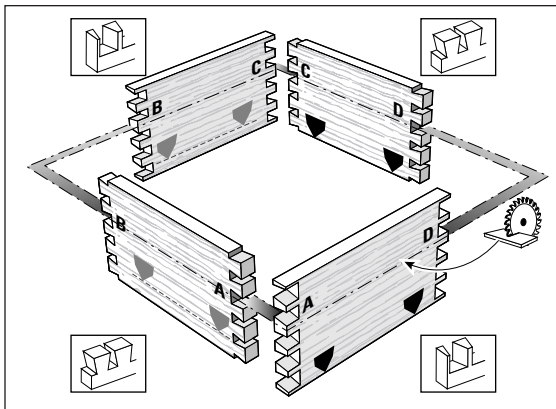
Deliberately asymmetrical joints must therefore be routed on both ends of the jig using two separate, almost mirror-image layouts.

**13-6**

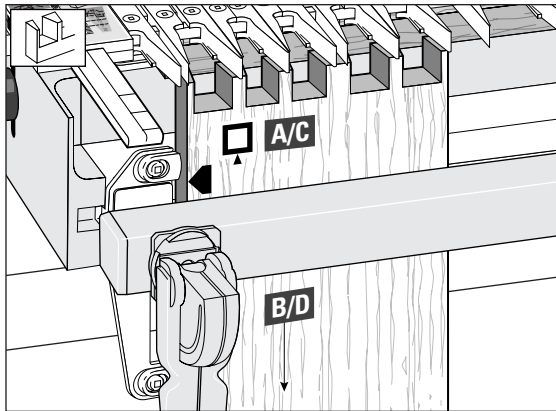
The layouts need not be exact mirror images because the parts that fit together will be made on the same end of the jig. For a typical blanket chest you would rout corners A and C on one end of the jig and corners B and D on the other end.

**13-7**

Here is an easy way to cut these near-mirror-image joints. Lay out the A and C corner joints in the usual way (i.e., in the  TD PINS mode). Rout the A and C corners' tails and pins. Leave the guidefingers set and in the  TD PINS mode.

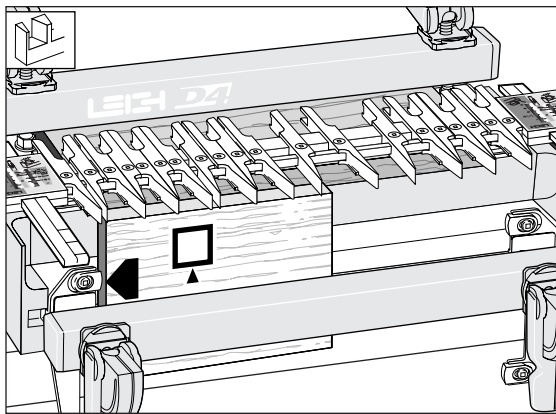
**13-8**

Take a square-cut scrap board wide enough to clamp **horizontally** in the front clamp and as long as (or slightly longer than) the width of the workpieces, and butt it against the same side stop you used for the A and C joints. Mark the board to indicate which face  is **out** on the jig.

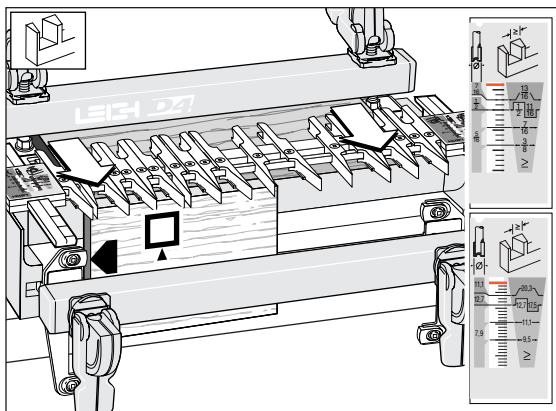
**13-9**

Pull the finger assembly forward until the bracket line is on the highest scale reading.

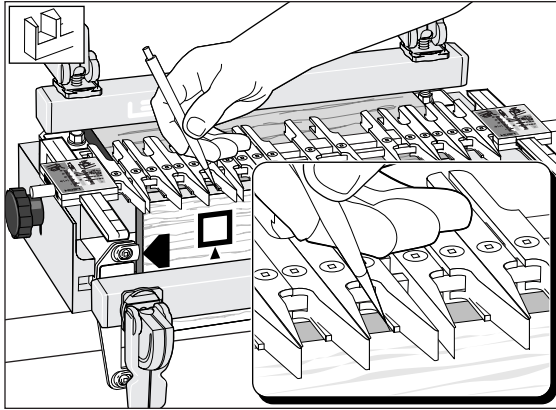
**13-10**

Mark pencil lines across the top edge of the scrap board, along the bottom of each side of each guidefinger or pair of guidefingers.

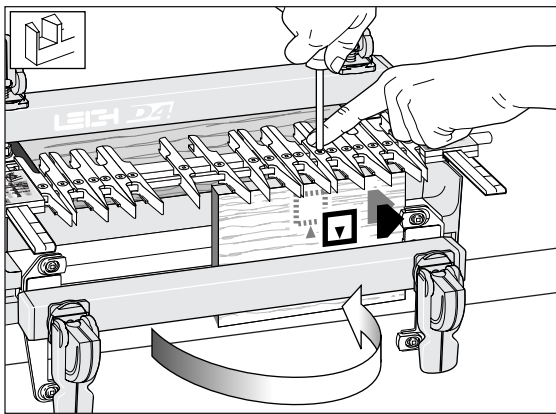
**13-11**

Turn the board (like turning a page of a book) to the other end of the jig and against the side stop, so the inside face \square is now away from the jig. Adjust the guidefingers at that end to match the pencil lines.

Note: See the next page for how to transfer half-blind mirror-images.

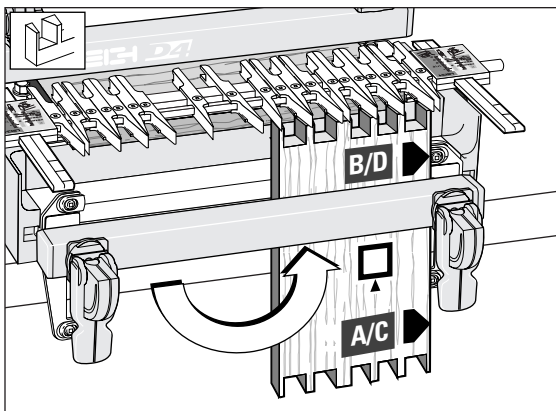
**13-12**

Now rout the B and D corners' tails and pins using this guidefinger pattern. When you assemble the case, the A and/or C ends will fit each other, and the B and/or D ends will also fit each other. Keep the boards inside face \square inwards on the case and the side-stop edges all turned the same way, and the parts are sure to match (see 13-6).

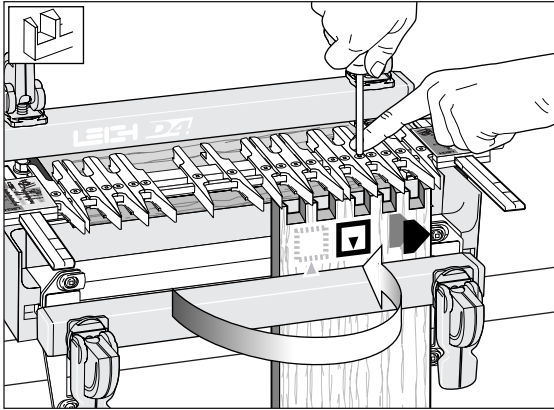
**13-13**

A quicker and only slightly less accurate way to “mirror” the guidefinger positions from one end of the jig onto the other end is to simply flip a completed A or C pin board from one end of the jig (like turning a page) to the other end, and centre each pair of guidefingers over a pin. (This is not so precise because you are aligning converging angles of pins and guides instead of straight lines.)

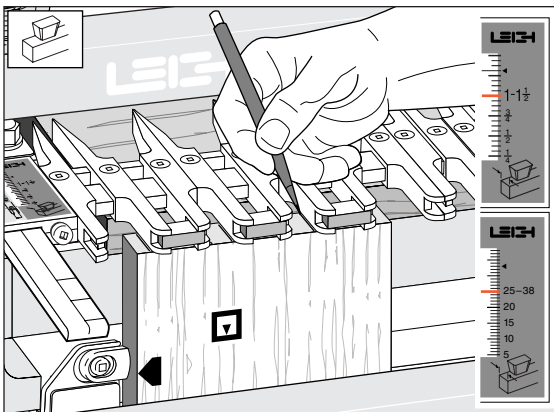
**13-14**

To transfer a **mirror image** asymmetrical half-blind joint, first set the scale on 1”[25mm] in the HB TAILS mode. Mark pencil lines next to the tail guides, and...

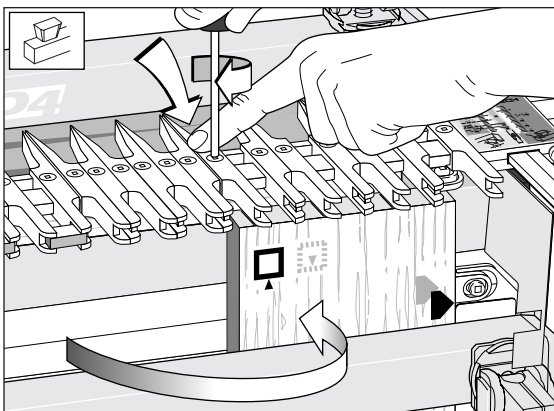
**13-15**

Turn the marked board (like turning a page of a book) to the other end of the jig. Position the guidefingers over the pencil marks.

This tail board layout may look symmetrical, but as the next illustration shows, it forms part of an asymmetrical joint.

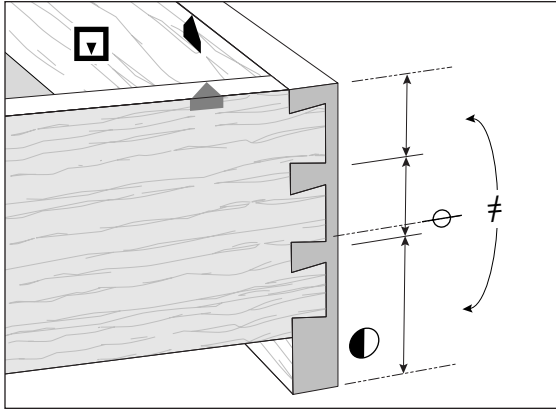
**13-16**

This common example of asymmetry is where boards are of a different width. In this case, a drop-front drawer, the drawer front bottom half-pin is much wider than the top half-pin. The top edges of the drawer front and sides are flush, so it makes sense to use these edges against the side stops at each end of the jig.

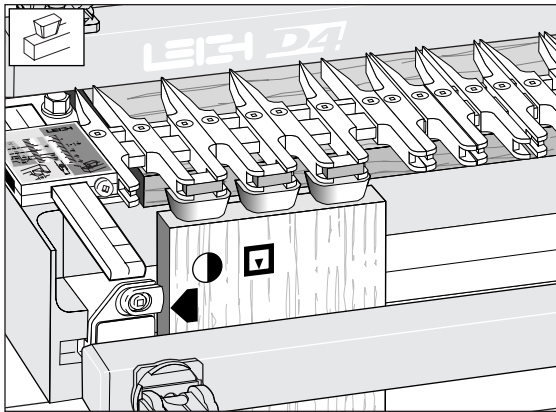
**13-17**

Mount the right hand ● drawer side on the left end of the jig for routing, and...

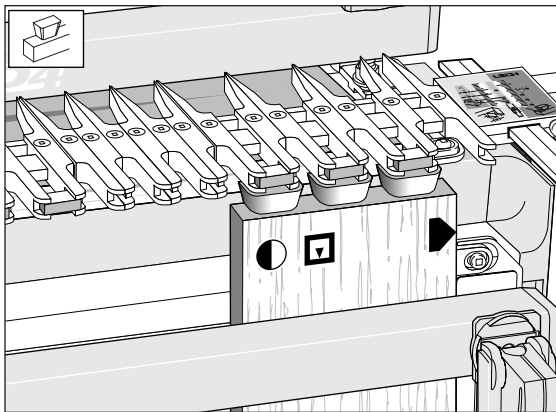
**13-18**

Transfer the joint layout from left to right (as in Figure 13-14 & 13-15). Mount the left hand ● drawer side on the right end of the jig.

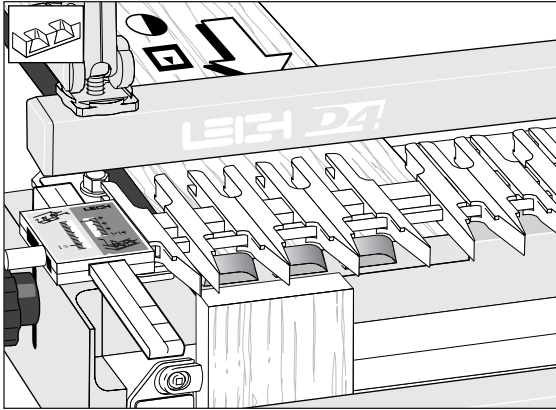
**13-19**

Mount the right end ● of the drawer front on the left end, and...

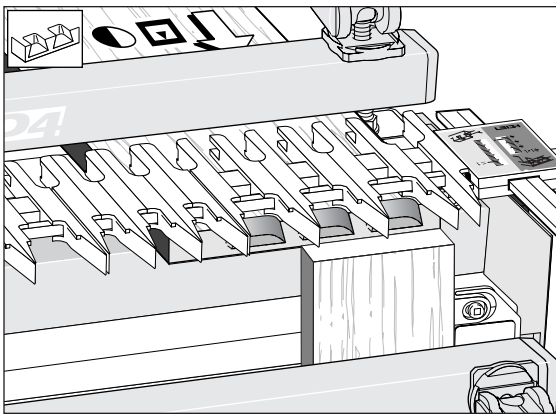
**13-20**

Mount the left end ● of the drawer front on the right end, using the **mirror-image** layouts on both ends.

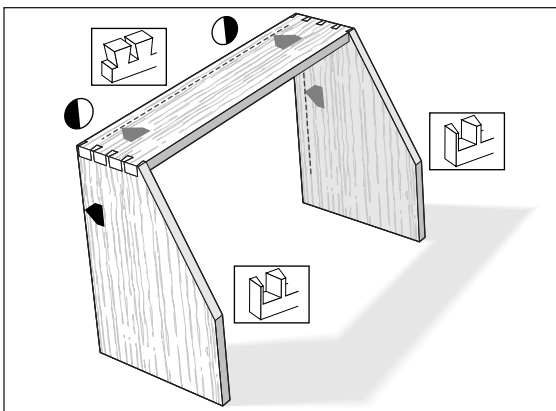
**13-21**

Both ends of the jig are also used for the top corners of a slant-front desk. The joints themselves may be symmetrical, but they must be routed on opposite ends of the jig because the sloped front will not register accurately against the fixed side stops.

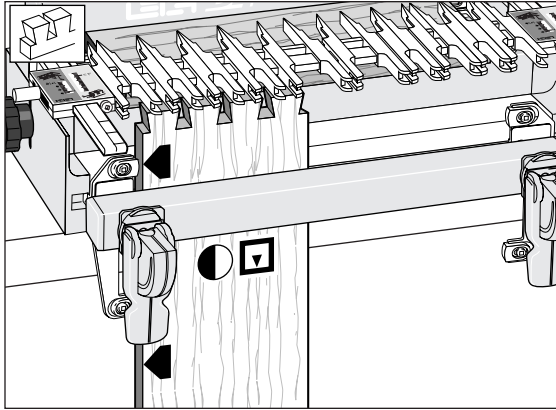
**13-22**

At the back of the desk both sides and top are flush, so the rear edges are set against the side stops. Place the left end ● of the top tail board against the left side stop ◼. Rout the tails.

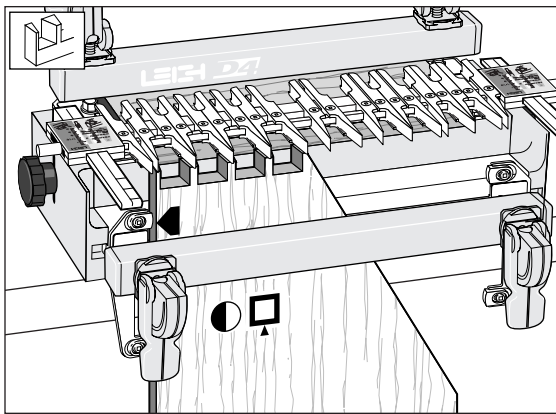
**13-23**

The left side ● of the desk goes against the left side stop ◼. Rout the pins.

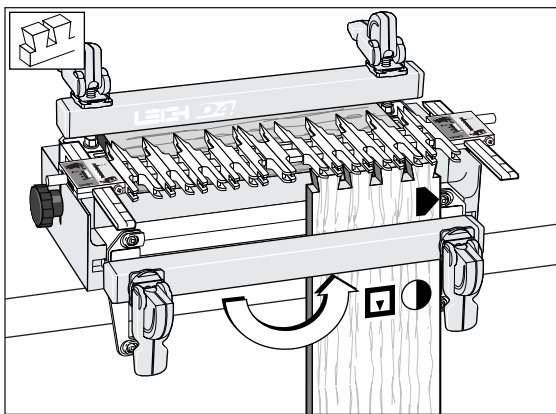
**13-24**

Transfer the joint layout from left to right (as for 13-8 to 13-11) and place the right end ● of the top tail board against the right side stop ◼. Rout the tails.

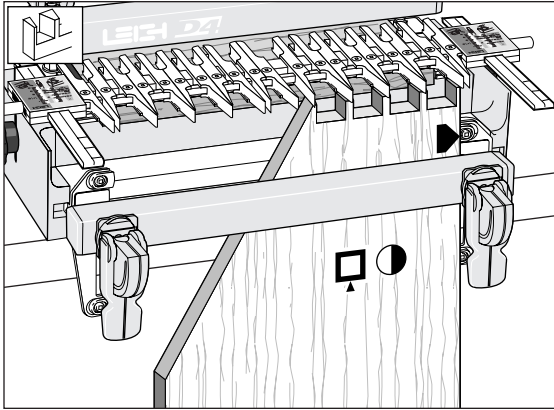
**13-25**

Place the right side ◐ of desk against the right side stop ▴. Rout the pins.

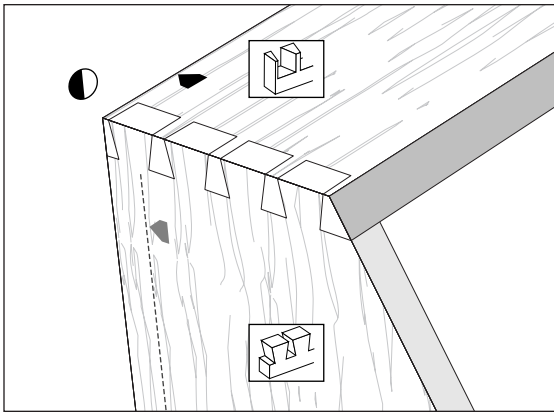
**13-26**

Note: If, in the slant-front desk example, the pins were in the desk top and the tails in the sides, then all the parts would be routed in the opposite ends of the jig to those shown above.

Sliding Dovetail Procedures

Chapter Foreword

Routing sliding dovetail “slots” across the face grain of horizontal boards is very tough on dovetail cutters. **Always use the largest shank size available to you;** we recommend at least 8mm shanks, but 1/2" would be even better, with of course the appropriate guidebush.

If you have to use 1/4" shanks in hardwood, use a second router to rough out the slot centre with a straight cutter.

We recommend 5/8" [15,9mm] as the minimum size guidebush for sliding dovetails.

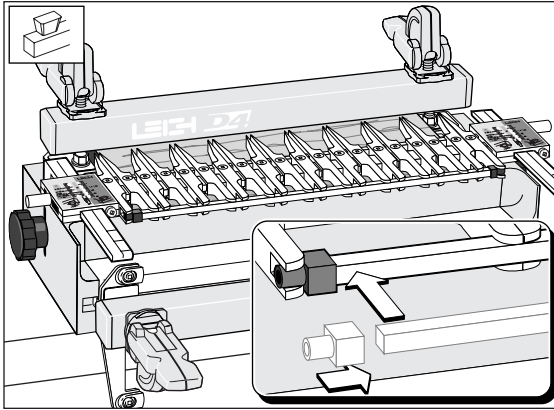
**14-1**

With the finger assembly in the  HB TAILS mode, the cross cut bar fits into the recesses in the ends of the tail guides to allow routing of sliding dovetails.

Note: On some jigs the cross cut bar caps may interfere with the guidebush at the start of the cut. If so, simply space the workpieces away from the side stops with a spacer block.

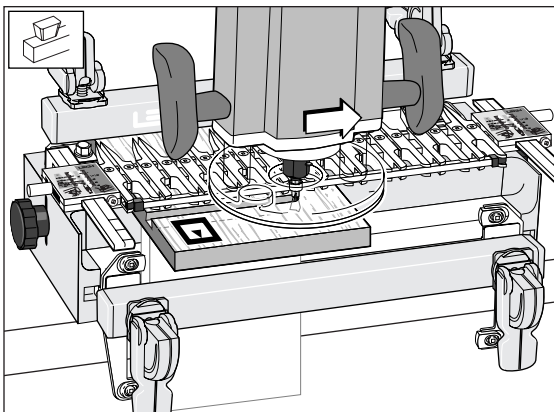
**14-2**

Using the cross cut bar as a guide surface for the guidebush, you can make lateral router cuts across the faces of horizontal boards (we call these dovetail *slots*), and...

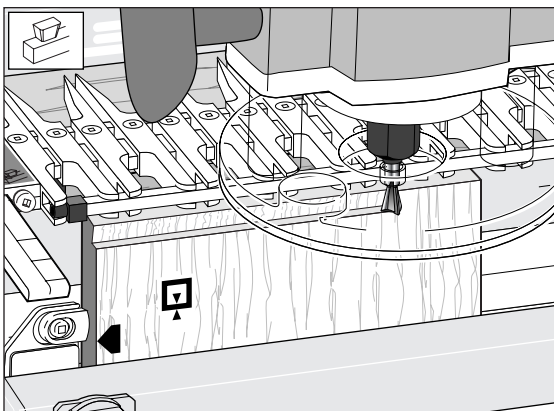
**14-3**

Across the top ends of vertical boards to cut the tail. First rout one side...

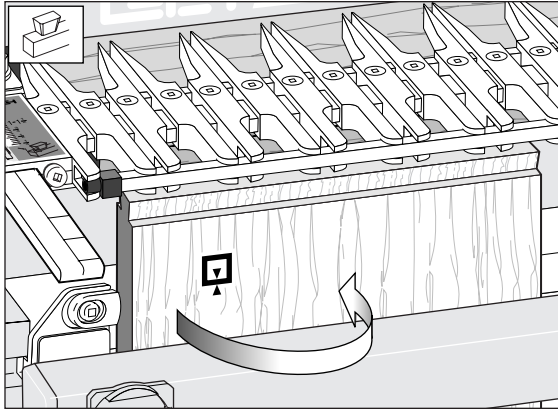
**14-4**

Then turn the board side-over-side to cut the other half of the tail.

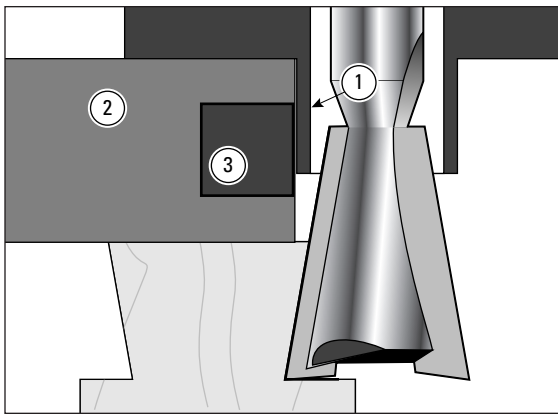
**14-5**

You can use virtually any guidebush/dovetail cutter combination for sliding dovetails, but the cutter angle should be not less than 10°. We do recommend 1/2" shank bits for sliding dovetails which would require 5/8" O.D. guidebush as minimum. Make sure the cutter can rotate without touching either the guidebush ① or the jig ②. The guidebush must project 1/4" to 5/16" [6 to 8mm] from the router base to securely engage the cross cut bar ③.

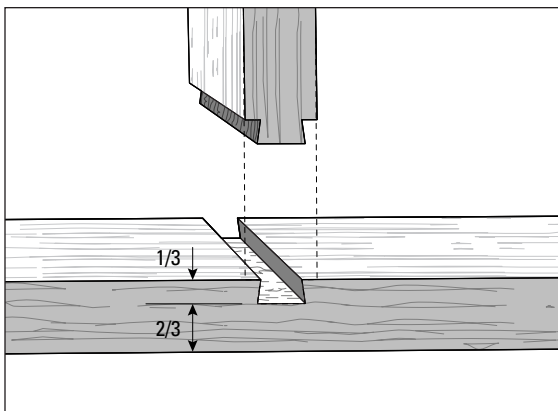
**14-6**

Sliding dovetail cutter selection:

If it is a full-width joint, *the slot depth-of-cut should be no more than 1/3 of the board thickness*, so as not to significantly weaken the board.

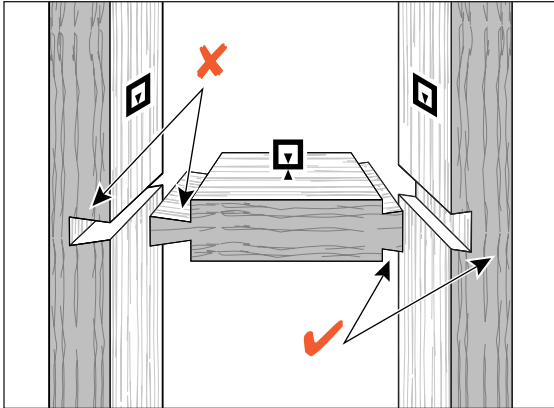
**14-7**

If the tail board is to be a load-bearing horizontal member (e.g., bookshelf or step), then make the tail fairly thick to ensure that the tail neck will be strong.

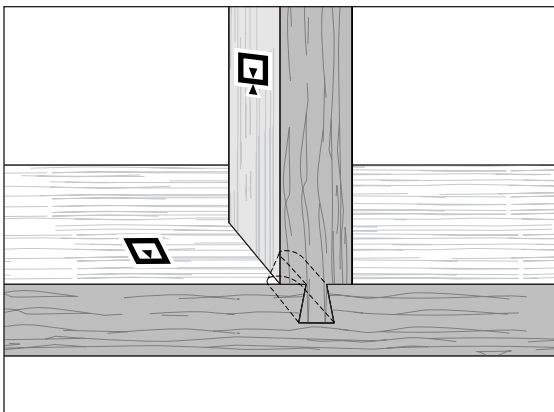
**14-8**

Shorter sliding dovetails with fewer structural demands on them may be slightly deeper, with narrower profiles, especially if appearance is important (e.g., where narrow rails join wider boards).

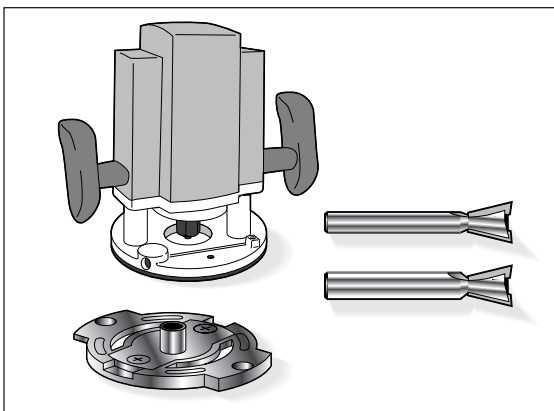
**14-9**

Now to cut sliding dovetails. Assuming you do not have a $\frac{1}{2}$ " shank cutter immediately available, mount a $\frac{7}{16}$ " [11,1mm] guide-bush on your router and use a No. 120 x 14° dovetail cutter, or preferably, a No. 120-8 cutter.

Note: No. 80 x 8° dovetail cutter is not suitable for sliding dovetails. The 8° angle is not sufficient for these relatively shallow interlocking cuts.

Chapter 14 D4 User Guide

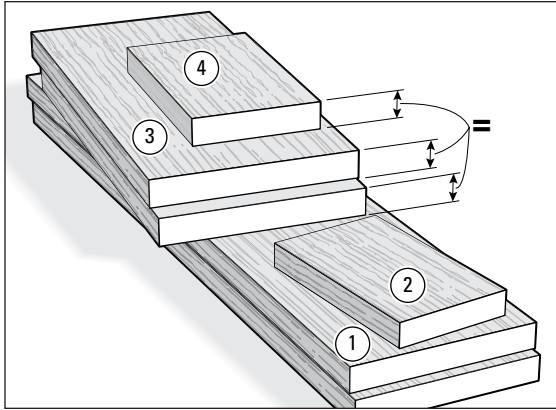
**14-10**

Use $\frac{3}{4}$ " x $5\frac{1}{2}$ " [20x140mm] softwood to make two slot boards ①, plus one narrow test slot board ②, two tail boards ③ and one narrow test tail board ④. The tail boards ③ and test tail board ④ must be exactly the same thickness. This will make two uprights and two shelves.

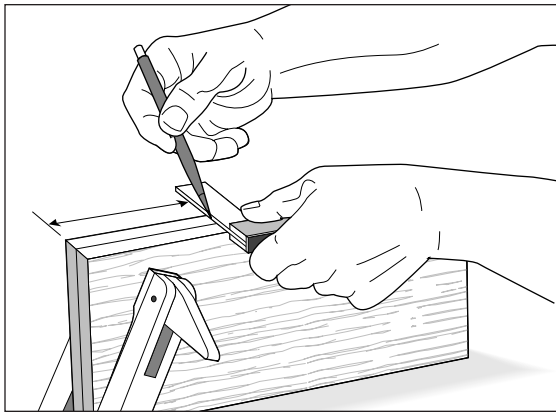
**14-11**

Marking Out: *Do not mark the slot positions on the board faces, but mark the edges of both slot boards together for perfectly level shelves. Stay at least 7" [180mm] in from the ends to allow for clamping on this test project. (Instruction number 14-37 describes how to rout close to both ends.)*

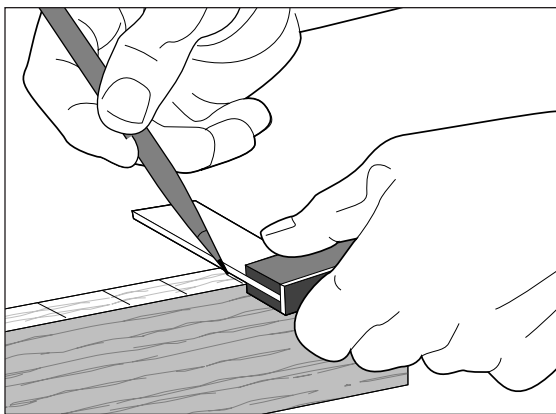
**14-12**

Mark the narrow test slot board in the same way at several closely spaced random spots. This board is used only for setup.

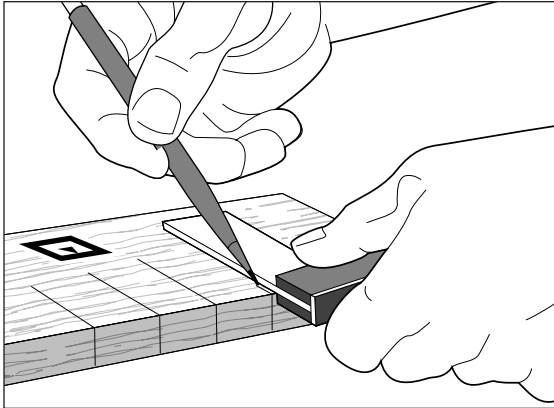
**14-13**

On the test slot board only, square the marks across the face.

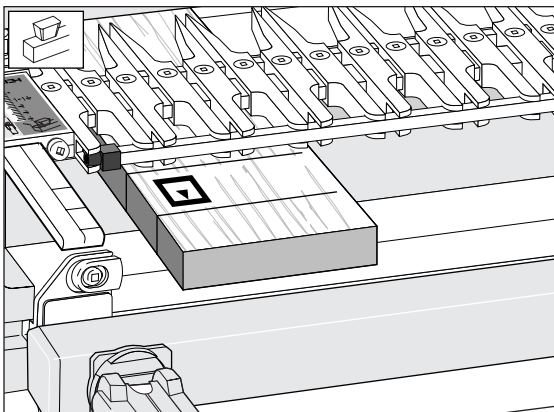
**14-14**

Mount the test slot board in the rear clamp, markings up.

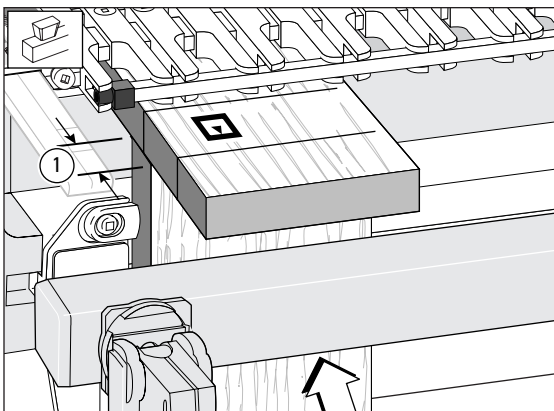
**14-15**

Mount a $\frac{3}{4}$ " [20mm] thick ① (yes, the $\frac{3}{4}$ " [20mm] thickness is important) square-ended board vertically in the front clamp against the side stop, with the top edge butting the underside of the test board.

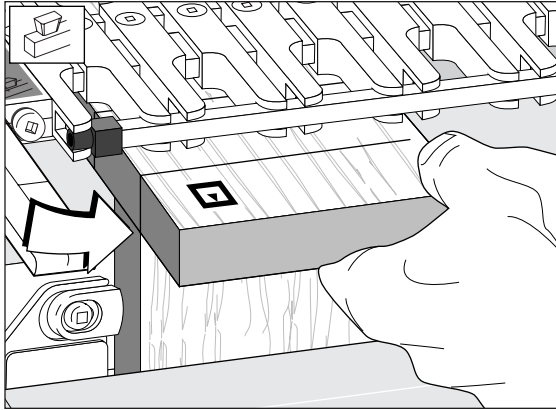
**14-16**

Position and clamp the test board so that one of the edge marks is in line with the *outside edge* of the vertical board.

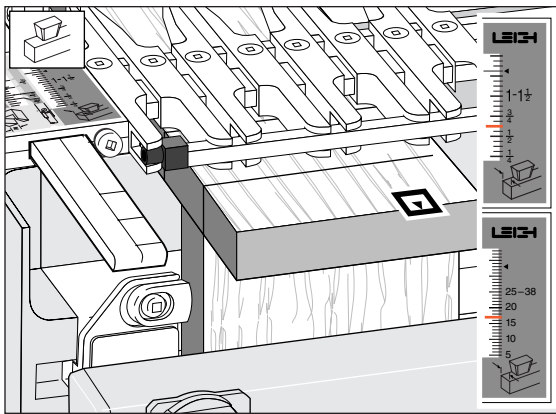
**14-17**

With the finger assembly (including the cross cut bar) on the support brackets in the HB TAILS mode, set the scale to $\frac{5}{8}$ " [17mm]. *Make sure the finger assembly is level and sitting flush on top of the board.*

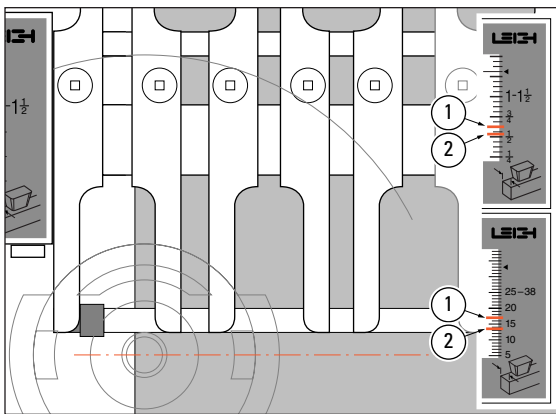
**14-18**

The HB TAILS scale was not designed for this operation, but with the $\frac{7}{16}$ " [11,1mm] guidebush and the scale set on $\frac{5}{8}$ " [17mm] ①, the routed slot will be close to centred on the slot line.

Note: If you use a larger guidebush than $\frac{7}{16}$ " [11,1mm], move the scale in by the difference of the two guidebush radii.

E.g., the suggested scale reading for a $\frac{5}{8}$ " guidebush would be $1\frac{7}{32}$ " [13,5mm] ②.

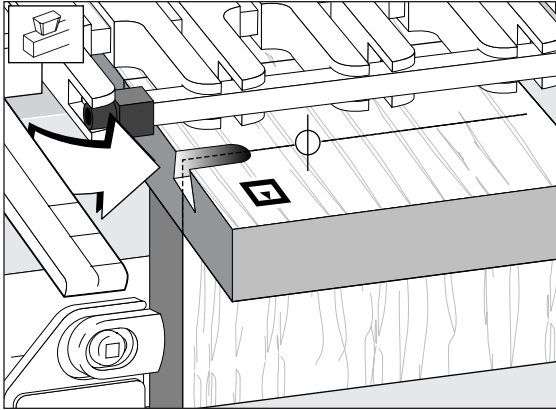
**14-19**

Adjust the cutter so the cut depth is about $\frac{5}{16}$ " [8mm]. Rout from left to right maintaining light inward pressure of the guide-bush on the bar. Rout in only about 1" [25mm] and back out again.

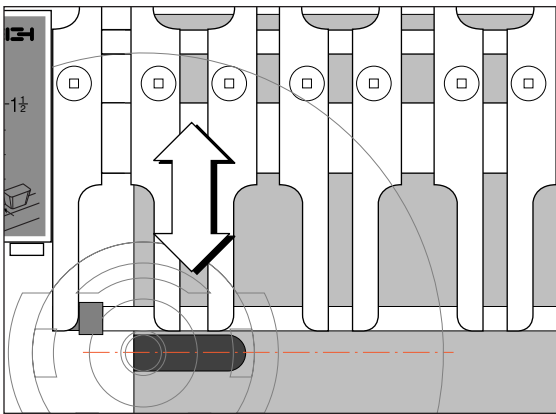

Do not lift the router.

**14-20**

Check to see if this short slot is centred on the pencil line. If not, adjust the finger assembly in or out and retest on the other lines as necessary until the slot is centred. Lock the finger assembly in this position and record the setting for future reference.

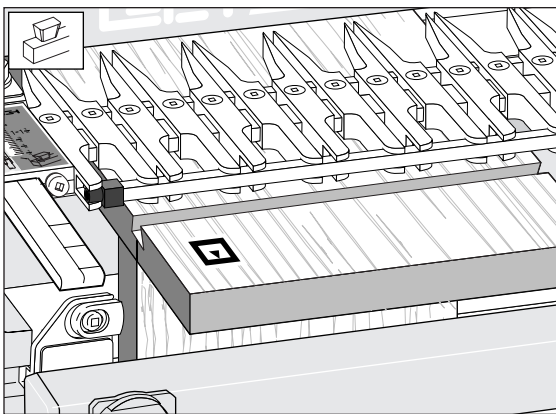
**14-21**

Now rout sliding dovetail slots in the two main slot boards with the boards in the horizontal position in the rear clamp, slot side, that is inside face \square up.

The guidefingers must be flush on the board.

Chapter 14 D4 User Guide

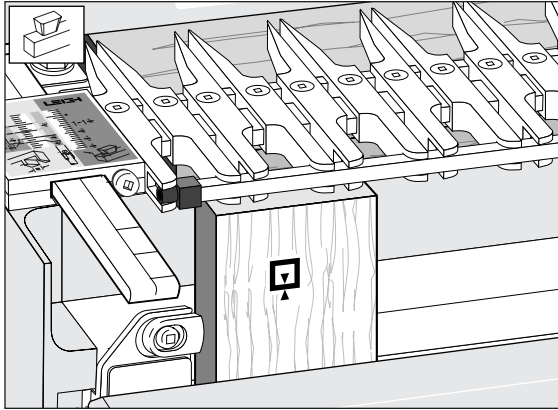
**14-22**

Replace the spacer board in the rear clamp, and with the finger assembly on the spacer board, mount a test tail board vertically in the front clamp, **flush under the guidefingers**. Either side can face out .

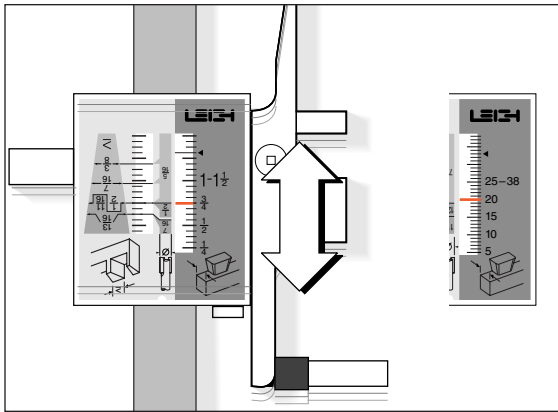
**14-23**

The  HB TAILS scale is not designed specifically for this mode, but it does allow you to make precise adjustments for tail size and tightness of fit on sliding dovetails.

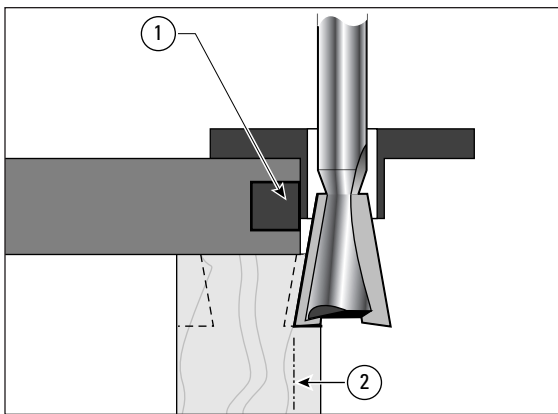
**14-24**

Adjust and set the finger assembly ① so it is clear that the routed tail ② will be too large for the slot.

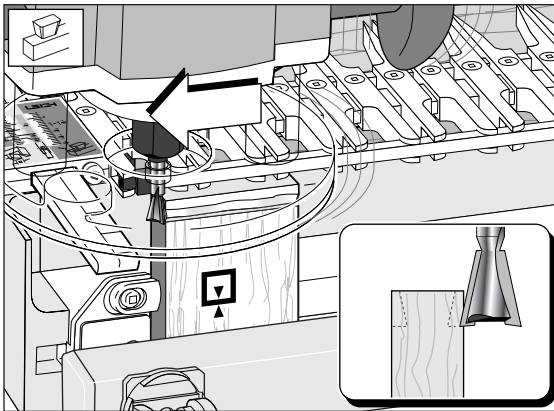

14-25  Rout one side of the test tail board. Make one light pass from right to left (climb routing). Make sure you control it firmly, because it is driven in this direction by the cutter. Only the tip of the cutter should be cutting on the first cut (see inset). This *back* or *climb* routing leaves a very clean shoulder in side grain.

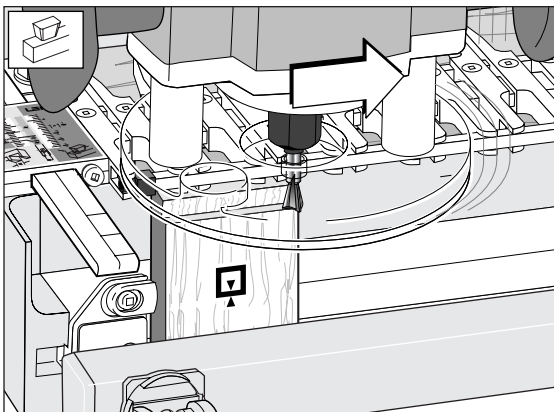

14-26 Finish left to right, with the guidebush touching the bar.

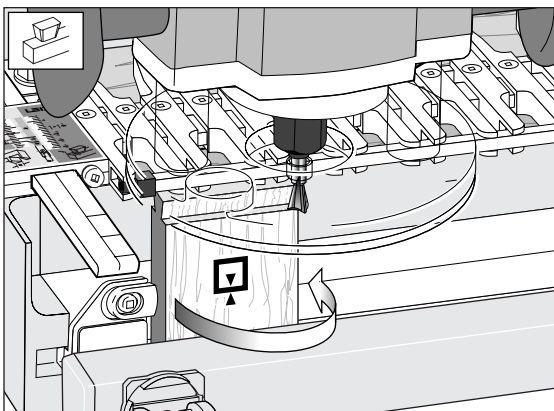

14-27 Turn the test tail board around in the jig and rout the other side as above.

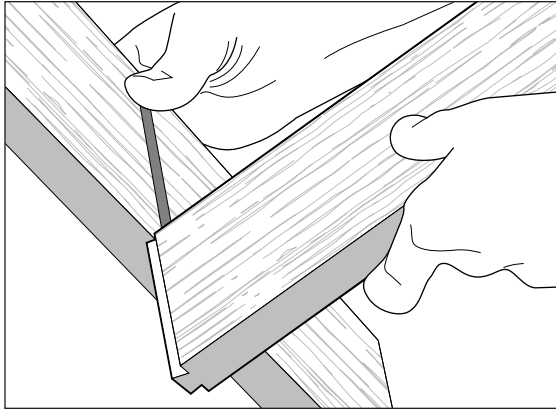
**14-28**

Test the joint for fit. The tail should be too big. If it is too small, adjust the finger assembly outward by at least half the difference and rout another test tail on the other end of this test board.

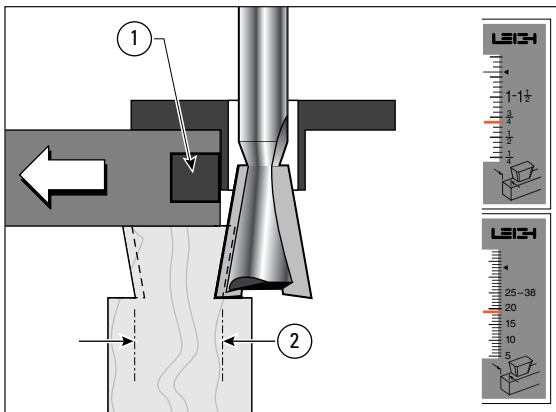
**14-29**

If the tail ② is too big, move the finger assembly ① in toward the jig by half the amount the tail is too big. Rout the same test board again and keep adjusting and testing until you have a good fit. Note: Variations in board thickness, guidebush diameter, cutter depth, angle, diameter and concentricity, make it impractical to record or chart scale settings for sliding tail size. Use trial and error each time. It doesn't take long, and you get a good fit.

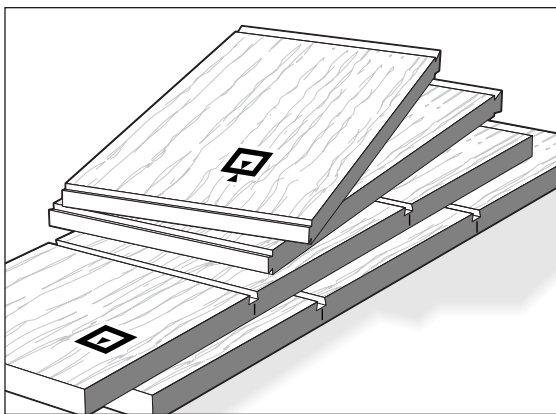
**14-30**

When the fit is satisfactory, rout one end of a project tail board and test again. If the fit is good, rout all the other ends.

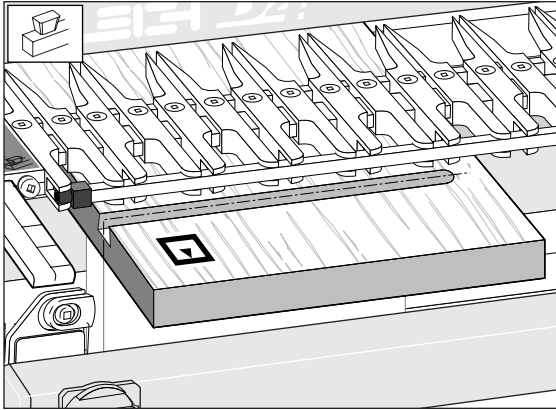
**14-31****Stopped Sliding Dovetails**

If a stopped sliding dovetail is called for...

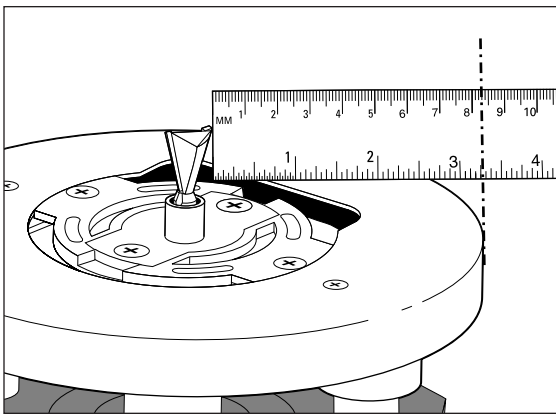
**14-32**

Measure from the outside tip of the dovetail cutter to the edge of the router base.

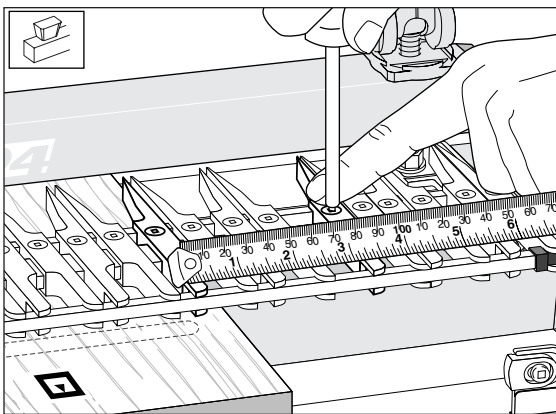
**14-33**

Measure the same distance from where you want the slot stopped to a position on the finger assembly. Move a guidefinger to that point and mark the guidefinger with a felt pen as a visual router stop mark...

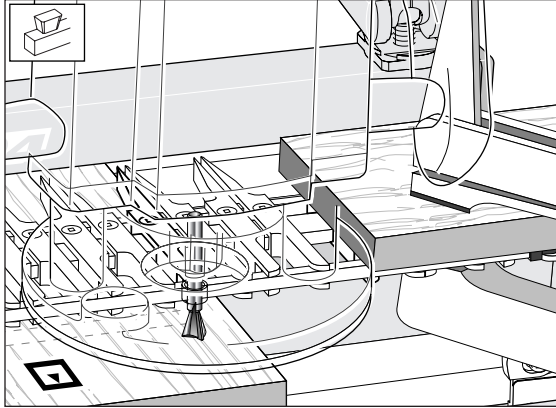
**14-34**

Or lightly clamp (with a soft-jawed clamp) a short board to the finger assembly to act as a router stop.

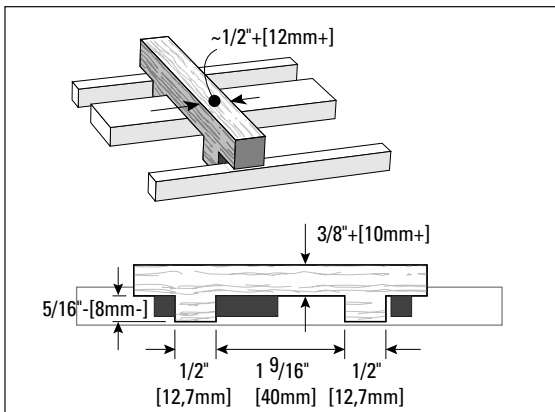
**14-35**

To cut numerous short stopped sliding dovetails in wide boards, make up this simple router stop.

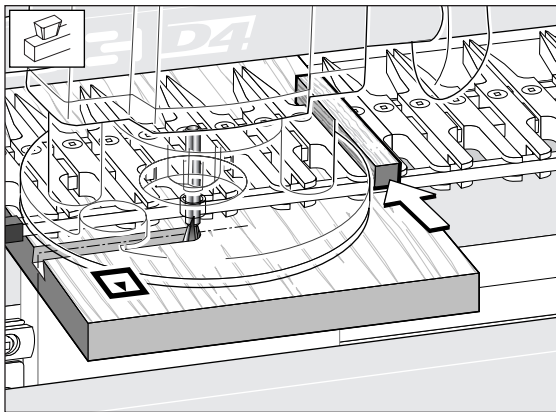
**14-36**

Trap the stop between a convenient pair of guidefingers and position them to suit.

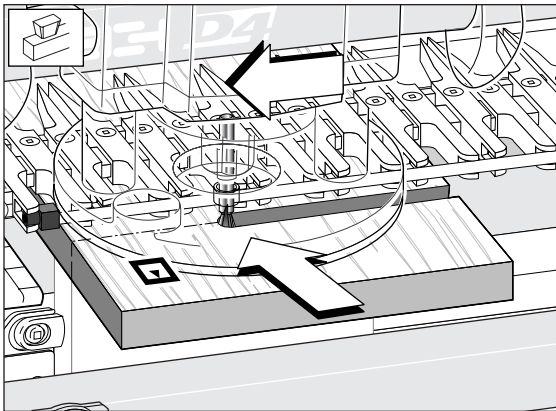

14-37

Dovetail slots are preferably routed from left to right because cutter rotation tends to keep the guidebush against the bar. However, when routing stopped slots in handed boards, or to rout close to both ends of a board, it is sometimes necessary to rout slots from right to left. Use a slower feed rate and maintain constant pressure of the guidebush on the bar for good results. But remember, the cutter rotation will tend to pull the router away from the bar.

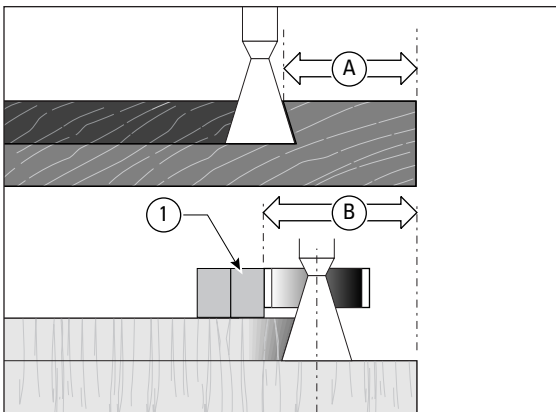

14-38

To rout a stopped tail to match a stopped slot, measure **A** from the end of the slot to the board edge. Calculate **B** this way:

B = A + guidebush radius – cutter radius.

B is how far the guidefinger ① will be from the edge of the tail board. Note: If the tail board edge is to be inset from the edge of the slot board (as when a shelf is inset from the front of a cabinet side) you must also subtract the size of the inset to get the correct value for **B**.

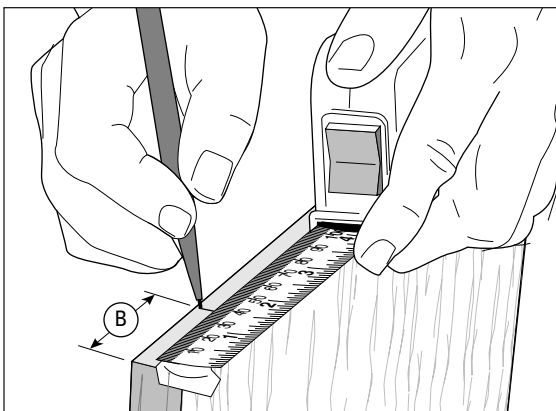

14-39

Measure and mark dimension **B** on the end of the tail board.

Chapter 14 D4 User Guide

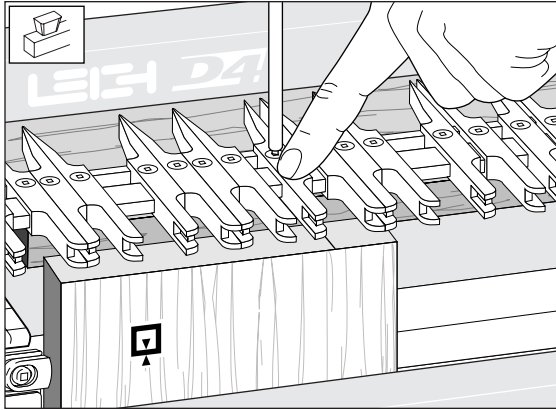
**14-40**

Position a (radiussed) guidefinger at this mark on the tail board end. **Do not leave a guidefinger in the area to be wasted.**

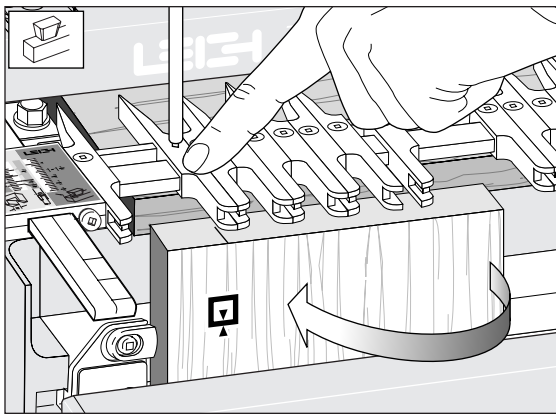
**14-41**

Turn the board side-for-side in the jig, and set another guidefinger on the mark. **Remember to move other guidefingers from the area to be wasted.**

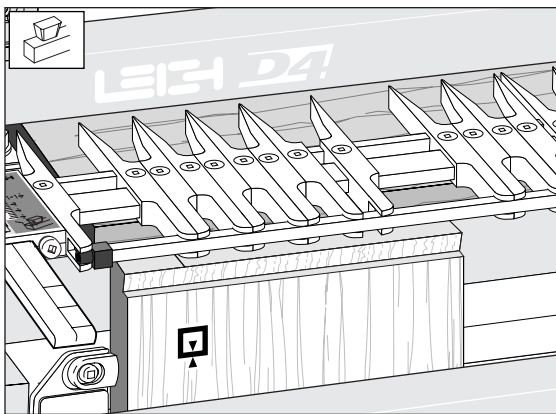
**14-42**

Establish the correct scale setting for the tail-to-slot fit (see pages 122 and 124). Then put on the cross cut bar, and after routing one side of the tail, remove the cross cut bar.

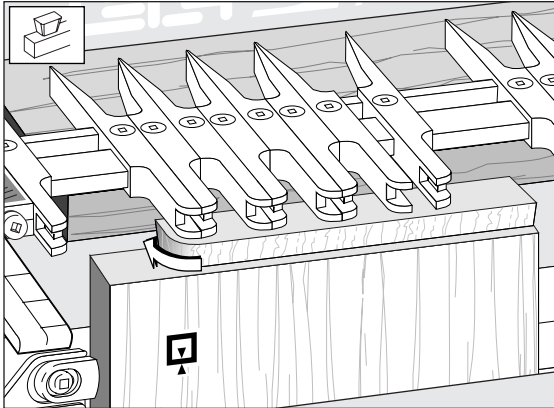
**14-43**

Then carefully rout around the guidefinger radius to form the shoulder.

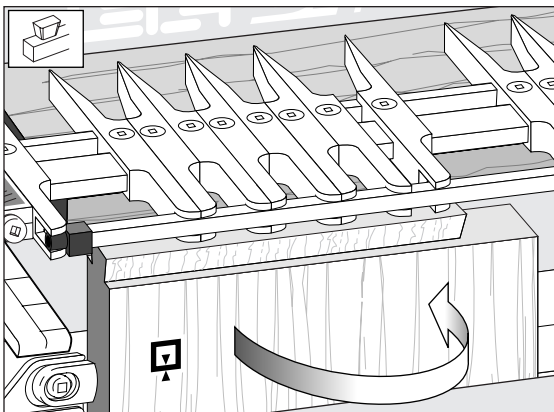
**14-44**

Repeat on the other side and...

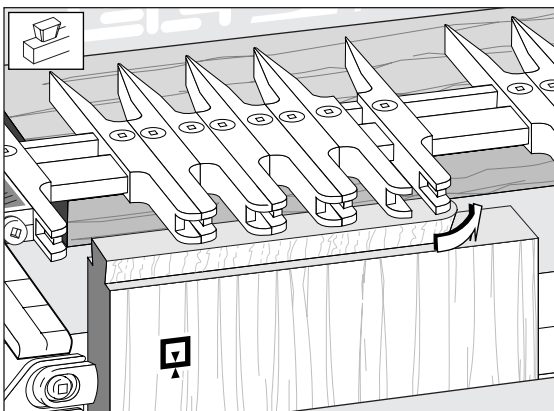
**14-45**

Remove the cross cut bar and rout the last corner of the shoulder.

Quick Reference Through Dovetails

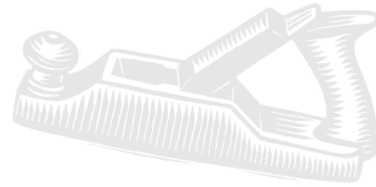
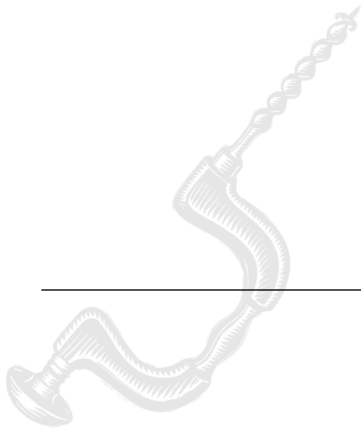

Chapter Foreword

You haven't used the jig for a while and just need reminding of the basics. Here they are for Through Dovetails.

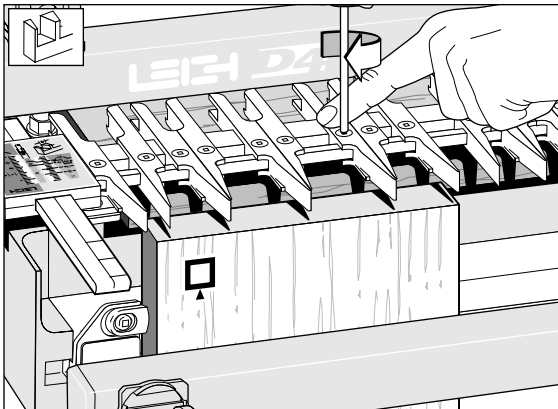
**15-1**

Through dovetails are laid out in the TD PINS mode with the finger assembly slightly raised above the spacer board and the pin board. The outside face of the TD pins is away from the jig body.

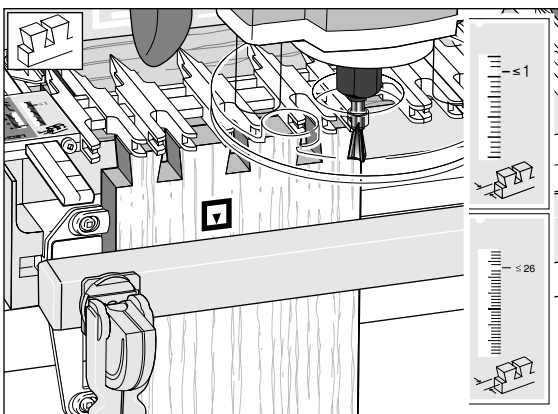
**15-2**

TD tail boards are clamped vertically in the jig. The inside face of the TD tails is away from the jig body. The finger assembly is in the TD TAILS mode, set on the single $\leq 1''$ [$\leq 26\text{mm}$] setting. There is only one setting in this mode.

**15-3**

Through dovetail tails are always cut with an 8° dovetail cutter to match the 8° guide-finger.

-

-

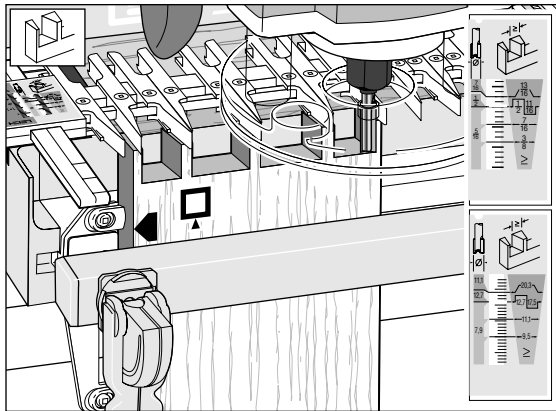

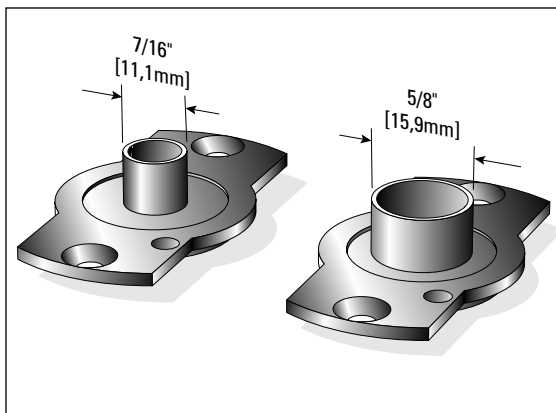

15-4

Clamp TD pin boards vertically in the jig. **This is the only one of the four main modes that puts the outside face of the board away from the jig body.** The finger assembly is in the TD PINS mode, with the scale set to a recorded setting (see detailed instructions to fit on pages 61 and 65). TD pins are cut with a straight cutter; **the only time a straight cutter is used in dovetailing.**

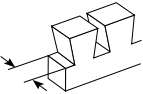
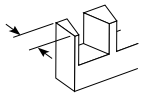

15-5

Guidebushes: When routing through dovetails with a 1/4" [6,35mm] or 8mm shank cutter, use a 7/16" [11,1mm] guidebush. The two large dovetail cutter combinations with 1/2" [12,7mm] shanks require 5/8" [15,9mm] guidebushes. So space the guidefingers at least 3/16" [5mm] apart (use the Leigh wrench) to accommodate the larger guidebush.

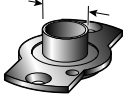
 Thickness of Tail Board	 Thickness of Pin Board	 Dovetail Cutter	 Straight Cutter	 Guidebush Diameter
up to 1" [26]	1" - 1 1/4" [26-32]	No.100	No.150	5/8" [15,9]
up to 1" [26]	5/8" - 1" [16-26]	No.90	No.160	5/8" [15,9]
up to 1" [26]	1/2" - 13/16" [12-20]	No.80	No.140	7/16" [11,1]
up to 1" [26]	3/8" - 5/8" [10-16]	No.75	No.140	7/16" [11,1]
up to 1" [26]	1/4" - 1/2" [6-13]	No.70	No.140	7/16" [11,1]
up to 1" [26]	up to 3/8" [10]	No.60	No.140	7/16" [11,1]
up to 1" [26]	up to 1/4" [6]	No.50	No.140	7/16" [11,1]

Numbers in brackets are millimetres

15-6

Here is a quick reference selection chart for through dovetail cutters and guidebushes. Please study the cutter and guidebush selection appendices for a full explanation.

-

-

Quick Reference Half-Blind Dovetails



Chapter Foreword

You haven't used the jig for a while and just need reminding of some of the basics. Here they are for Half-Blind Dovetails.

IMPORTANT REMINDER!

The most misunderstood aspect of routing half-blind dovetails is how the cutter angle affects the Depth of Cut setting. Theoretically, there is only one "perfect" depth of cut for a given cutter that will produce properly mating Pins and Sockets. Therefore, raising or lowering the cutter during test cuts is done only to achieve that one "perfect depth" that is determined by angle of the selected cutter. Any other depth will produce a joint that is too loose or too tight.

Please read this carefully and note the specified Depth of Cut for the different cutter angles shown.

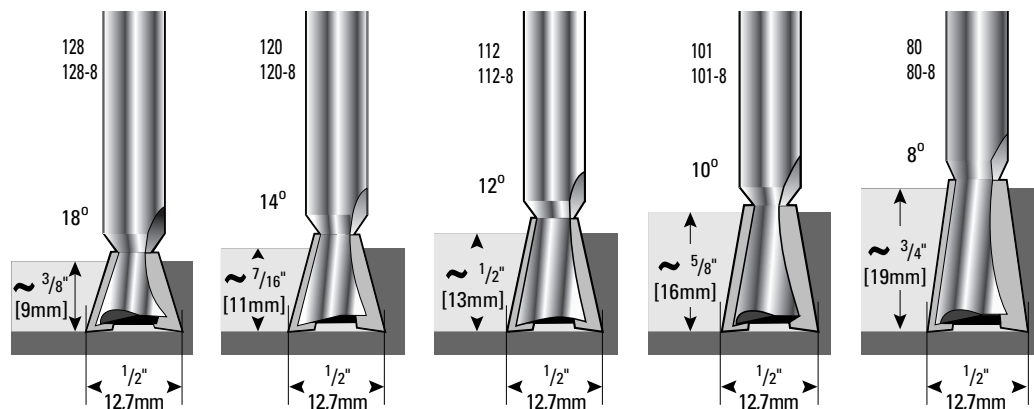

Important! Read This About Depth of Cut.

- Depth of cut must be as specified when using any of the four cutters illustrated above.
- Raising the cutter above its specified cutting depth will result in loose joints and may damage the jig, cutter and/or guidebush. A lower setting will result in tighter joints that may not fit together.
- Minor Depth of Cut adjustment will change the tightness of joint fit. See 10-14 to 10-16 to find out why.
- Half-blind PINS and TAILS are routed with the same dovetail cutter and must be at the same Depth of Cut.
- Choose one of the four 1/2" [12,7 mm] diameter dovetail cutters shown above, and check cutter selection on page 160.
- Use only 7/16" [11,1 mm] outside diameter guidebushes.

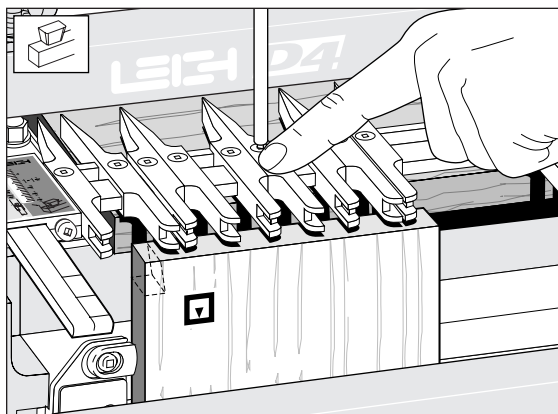



16-1

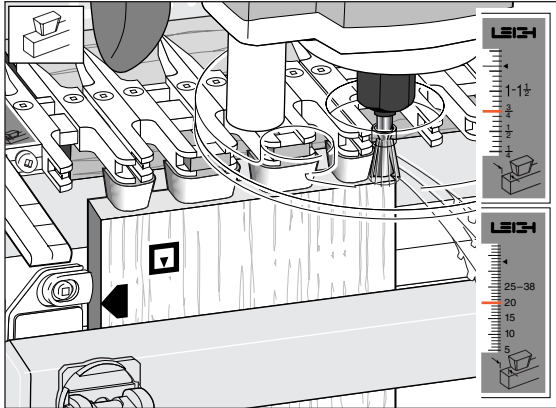

Half-blind dovetails are laid out in the  HB TAILS mode with the finger assembly slightly raised above a tailboard (e.g., drawer side).

Chapter 16 D4 User Guide

**16-2**

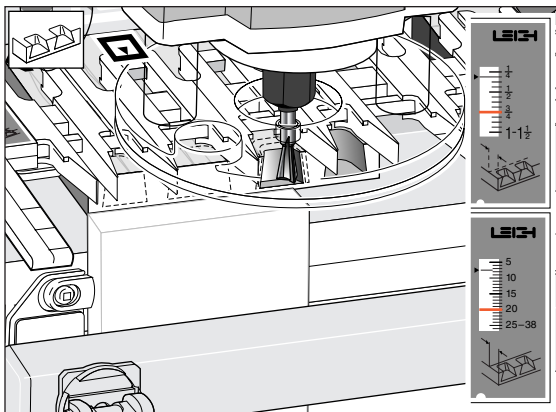
Half-blind (HB) tails: Drawer sides are clamped vertically in the jig. The inside face  of the drawer side goes away from the jig body. The finger assembly is in the  HB TAILS mode, **set to the thickness of the drawer side**. Use bridge pieces where required (see 10-10).

**16-3**

Half-blind (HB) pins: Drawer fronts are cut with the board clamped horizontally in the jig. The inside face  of the drawer front faces away from the jig body. The finger assembly is in the  HB PINS mode, and again **set on the thickness of the drawer side** (but adjusted for a flush fit, see page 87).

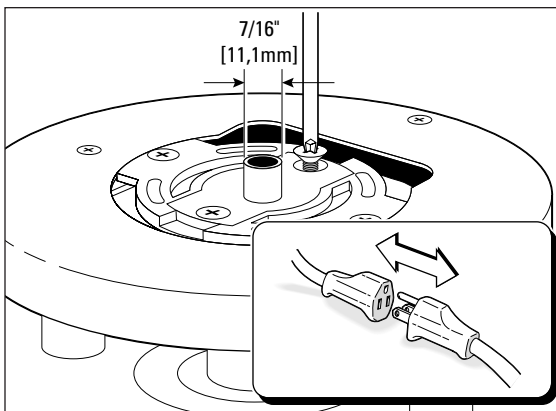
**16-4**

On the Leigh jig, **all half-blind dovetails are routed using a $\frac{7}{16}$ " [11,1mm] O.D. guidebush.**

Hints and Tips



Chapter Foreword

Here are some special techniques and ideas to help you get the most out of your Leigh jig.

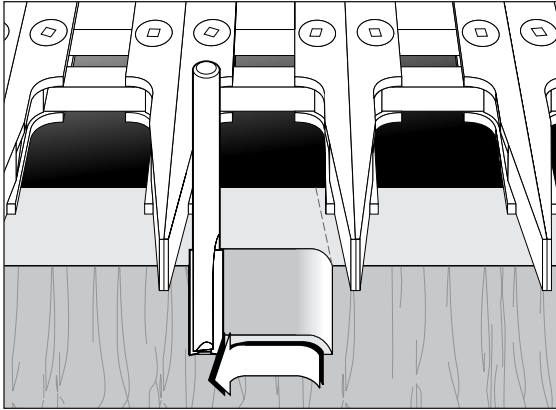
**17-1**

With the straight cutter, carefully climb-rout from right to left. Make sure you control the router firmly when climb routing. Note: For clarity, the guidebush is not shown in this sequence.

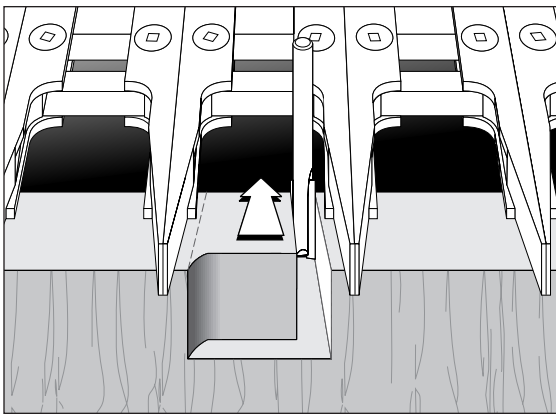
**17-2**

Rout through on the right side.

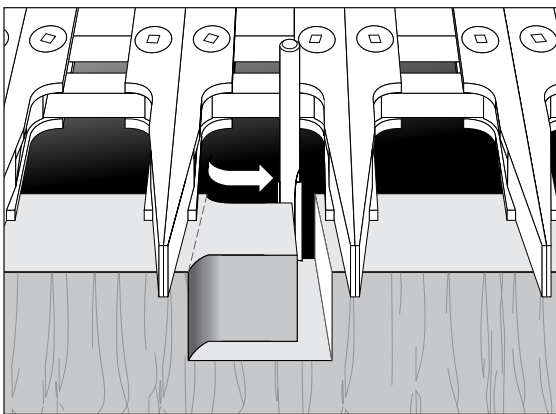
**17-3**

Climb rout from left to right from the rear of the cut. Take care to control router.

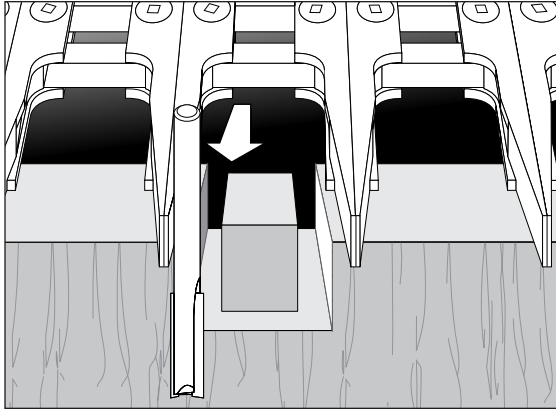

17-4  Rout back through towards you on the left side.

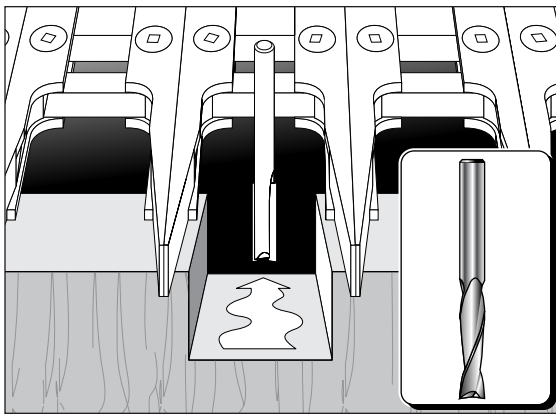

17-5 Rout away the rest of the waste.
Note: Spiral up-cut straight cutters (inset) generally rout more smoothly than the two-flute carbide-tipped bits. If you want to try them, you should be aware that while the high-speed steel bits take a better edge, they are much less durable than the more costly solid carbide type.

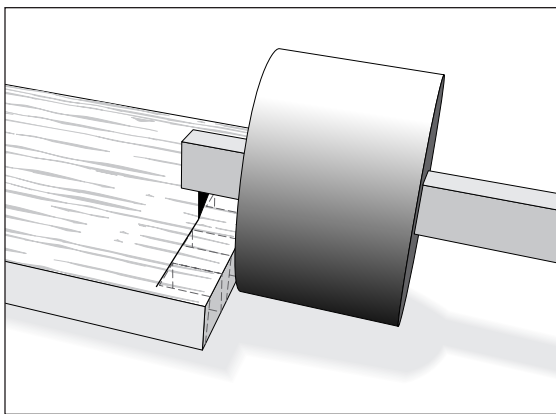

17-6 Through Dovetail Pins Tearout
 To prevent tearout at the back bottom part of a straight cut, scribe a line with your marking gauge across the back of the pin board at exactly the depth of cut.

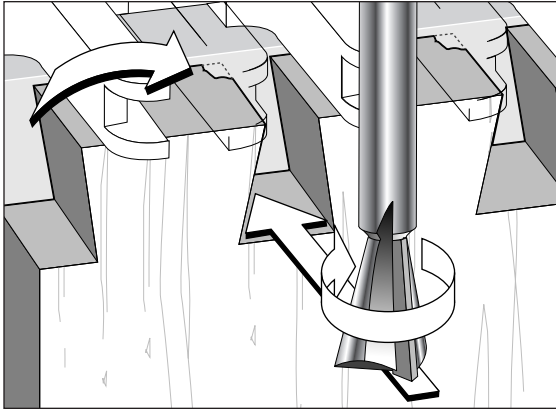
**17-7 Dovetail Tails Tearout**

With the dovetail cutter, most tearout occurs at the top left exit of the cut.

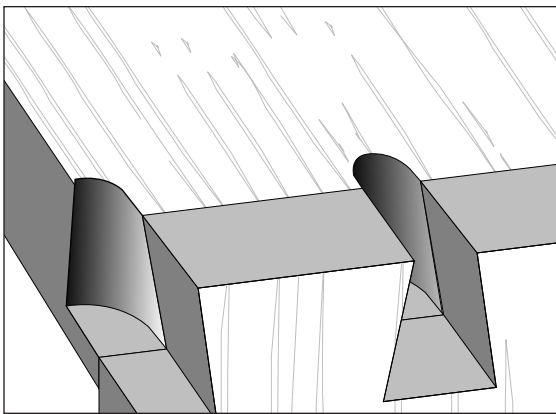
**17-8**

To help prevent this, back up the cut with the end-grain of a horizontal board pushed against the back of the workpiece and held in the rear clamp. This board replaces the spacer board.

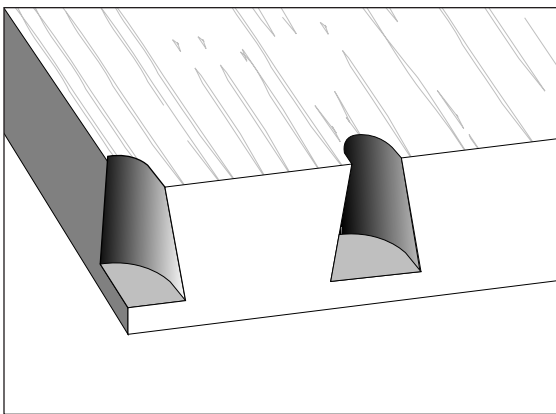
**17-9**

This same scrap piece can remain in place for successive cuts.

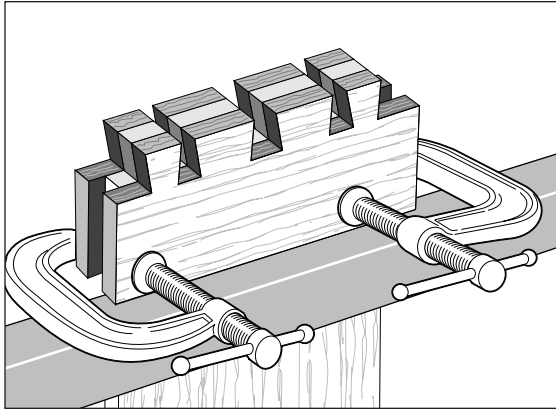
**17-10**

For particularly vulnerable pieces or that last piece of exotic wood, the best solution is to clamp horizontal scrap pieces to front and back of the work piece. **Make sure the clamps are below the cutter depth.**

 **PLYWOOD**

Plywood is not a suitable material for routing; the laminates are very prone to tearout. Either of these two procedures (17-10, 17-11) are essential for plywood but provide no guarantee of success.

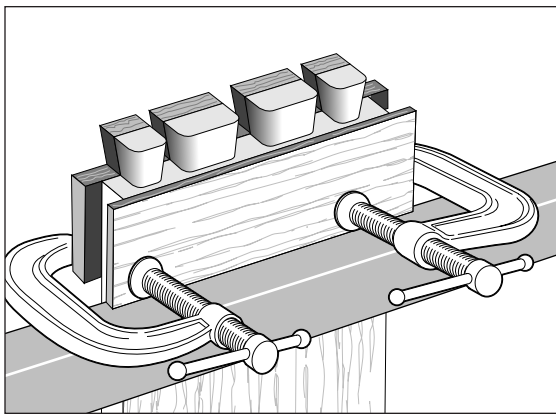
**17-11**

A single scrap piece can be C-clamped on the back of half-blind tails, *but make sure you protect the workpiece from the clamp pads.* Note: There is no 100% solution to tearout. It's not the jig's fault, just something that happens when machining, sawing and even chiseling wood. Important pieces fall off from where you least want them to.

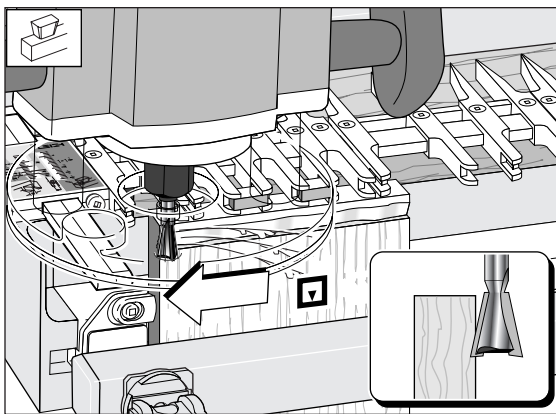
**17-12** 

On face cuts, whether using a straight cutter or a dovetail cutter, climb routing or back routing will leave a clean edge; **but great caution must be exercised in controlling the router's movement from right to left, as the cutter rotation pulls the router in that direction anyway.**

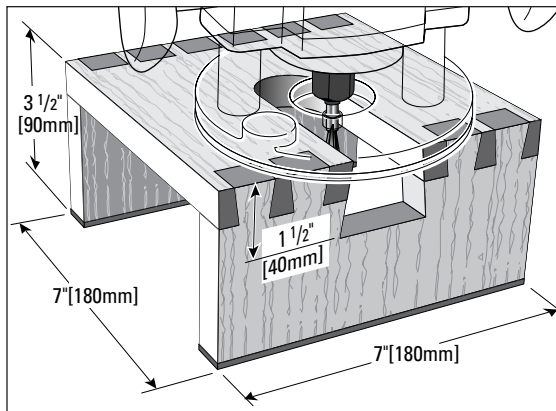

17-13 General Hints

Router Stand: Make up a small router stand as illustrated, to mount the router securely on the bench when not in use.

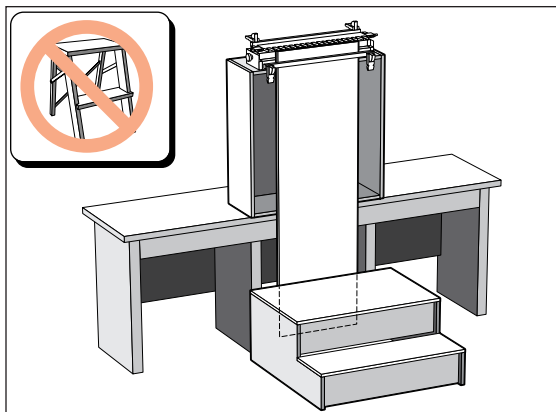

17-14

For routing long vertical boards it may be necessary to build a jig stand to mount securely on your bench. Make the stand and bench height combination sufficient to accept the board length you have in mind. *The jig stand should be bolted securely to the bench.* Make up a stable platform to stand on as in the illustration. **Do not use a set of steps.** Steps are not stable enough.

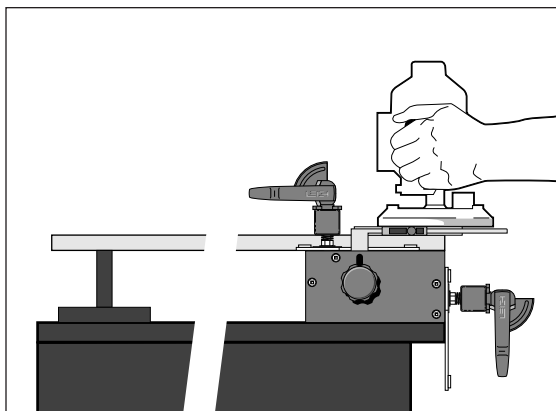

17-15

When placing long horizontal boards in the rear clamp, make sure the rear end of the board is supported to prevent unnecessary racking of the jig.

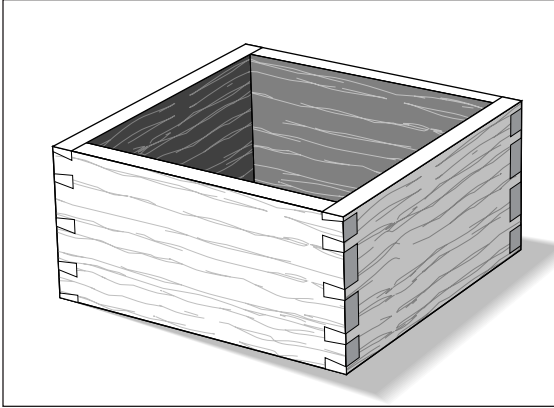
**17-16 More On Symmetry**

It doesn't matter if symmetrical-looking joints on a single box do not precisely mirror the adjacent corners. No one will ever know the difference. These joints look perfectly symmetrical on their own, but...

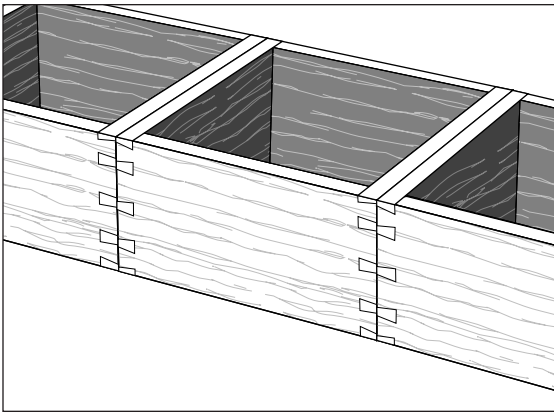
**17-17**

If a number of these boxes end up side-by-side, the slight misalignments of the joints could be unattractive. So when making boxes or through dovetail drawers that will be lined up beside each other with the joints showing...

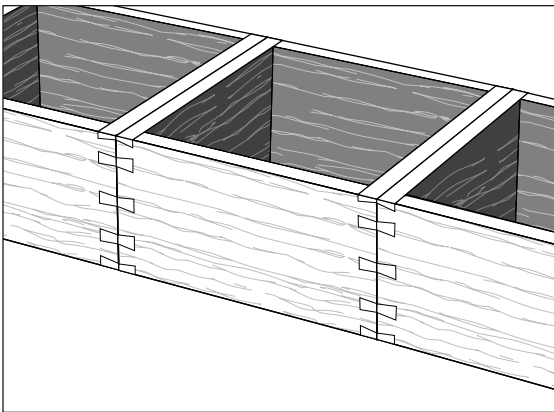
**17-18**

Use the asymmetrical *mirror image* aligning techniques on pages 104-106 for perfectly aligned *neighbour* joints.

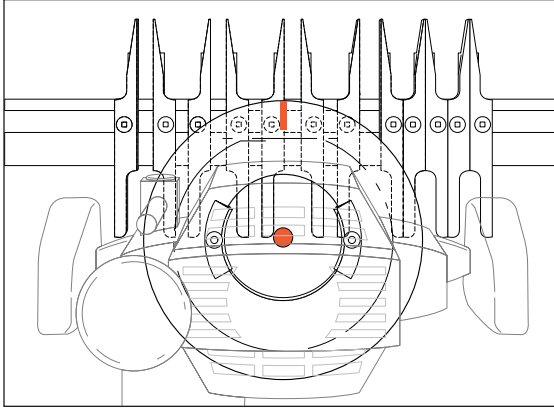

17-19 Using The Router

Mark the router base top edge at the 12 o'clock position with a felt marker pen. Without wood or cutters, try some **dry runs** in each jig mode. This will soon get you used to positioning the guidebush against the correct guide surface without looking under the router.

 **Do not rout at face level.**

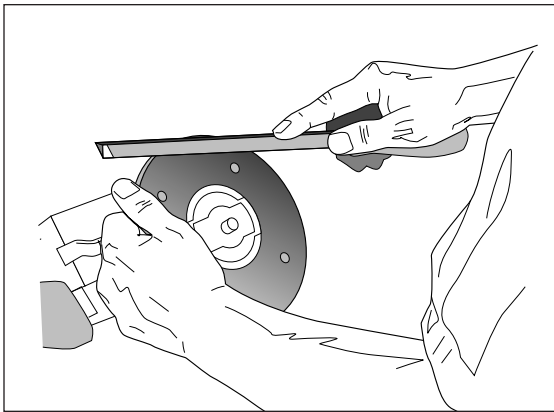

17-20

Some router bases have sharp edges on the outside and inside corners. A slight chamfer of the edges with a fine file or sandpaper block will ease router movement on the jig.

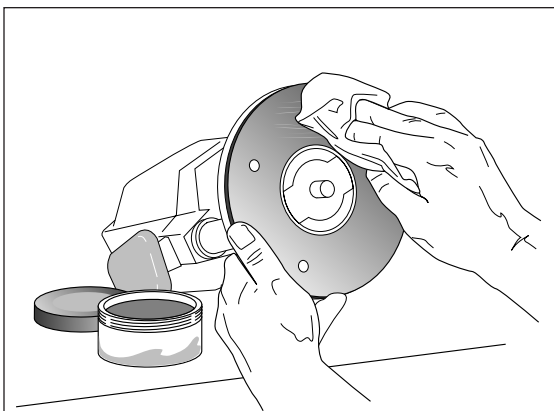

17-21

An occasional very light application of soft wax on the router base makes for smooth easy router movement on the jig.

Guidebush Selection

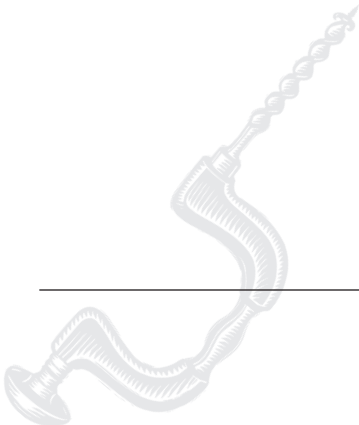

Foreword

The correct guidebush is the vital link between the router and your Leigh Jig. It precisely steers the router. Where possible, always use the Leigh system **to ensure correct bush length and precise diameter for accurate results.**

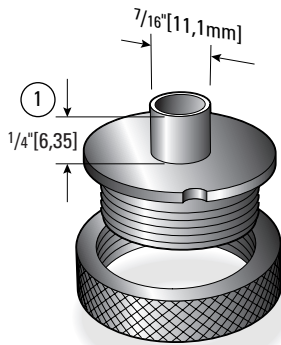

711 TP

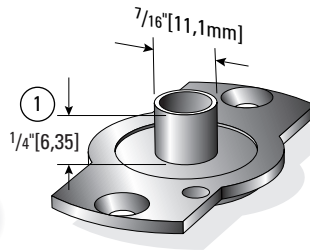

711

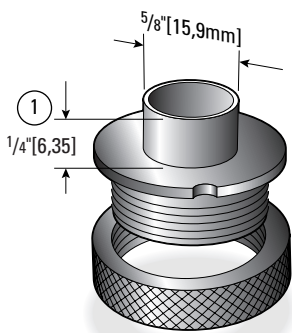

716 TP

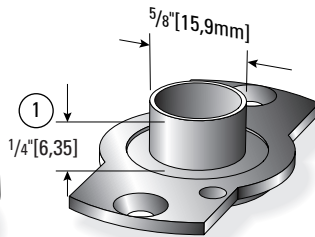

716

Guidebush Selection

Only two sizes of guidebush are used with the Leigh jig*: $\frac{7}{16}$ " [11,1mm] O.D. (outside diameter) and $\frac{5}{8}$ " [15,9mm] O.D.

Bush barrel length ① from base of router should be $\frac{1}{4}$ - $\frac{3}{32}$ " [6 - 7mm].

Use $\frac{7}{16}$ " [11,1mm] for all half-blind dovetailing and for through dovetailing with $\frac{1}{4}$ " [6,35mm] or 8mm shank cutters: i.e., dovetail cutter Nos. 50, 50-8, 60, 60-8, 70, 70-8, 75, 75-8, 80, 80-8, 101, 101-8, 120, 120-8, 128, 128-8, and straight cutter Nos. 140 and 140-8.

Use $\frac{5}{8}$ " [15,9mm] O.D. for large through dovetail cutter combinations with $\frac{1}{2}$ " [12,7mm] shanks: i.e., cutter Nos. 90, 160, 100, 150.

Here are the two types of Leigh guidebush and five Leigh adapters. Use the chart on page 153 to select the adaptor and/or guidebush required for your router.

**Except for sliding dovetails (see page 113).*

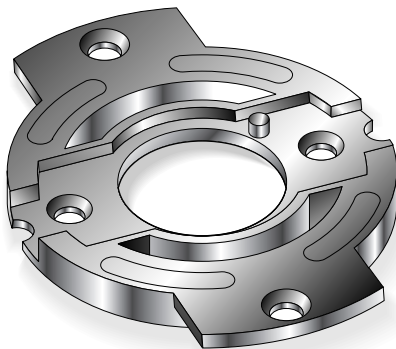

Adapter No. 702

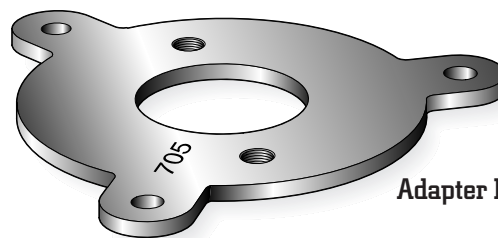

Adapter No. 705



Adapter No. 706

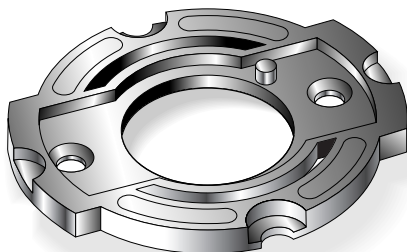

Adapter No. 703

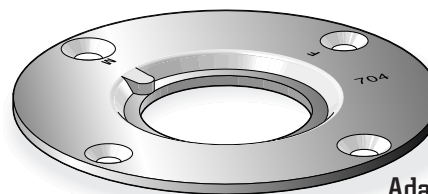

Adapter No. 704

Appendix I D4 User Guide

Leigh 711 and 716 guidebushes fit directly to some routers using the screws that come with the router.

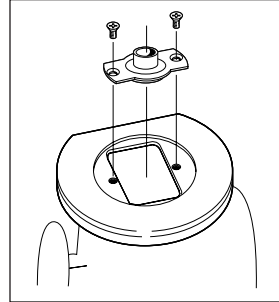

Leigh 711TP and 716TP (TP stands for Two Part) fit directly to Porter Cable and most Black & Decker routers.

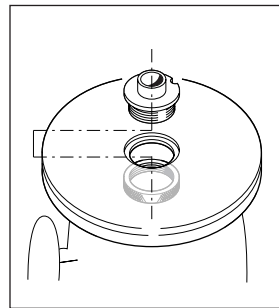

Leigh universal adapters fit to a wide range of plunge routers and accept both types of Leigh bush.

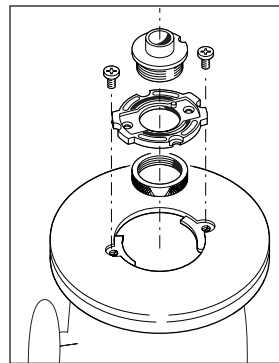
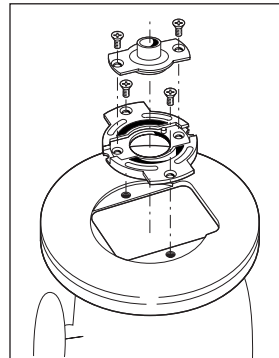

Check the make and model of your router in the left hand column. Where possible always order the Leigh adaptors and guidebushes (in red) which are specially designed for use on Leigh jigs. Other adaptors or guidebushes must be purchased from the manufacturer's own distributor.

Note: Ideal barrel depth is 1/4" to 9/32" (6mm to 7mm) below the router base. Other manufacturers' guidebushes may require careful cutting to length.
 ♦ Guidebush mounting screws are provided with adaptor and adaptor mounting screws are provided with router.
 ▼ 5/8" (15.9mm) O.D. guidebushes are used only with 1/2" (12.7mm) shank router bits. ■ MAPELL – Rework the adaptor slightly. ● SCHEER – Rework the router base slightly.

ROUTER MAKER	ROUTER MODEL	LEIGH OR ROUTER MAKER'S ADAPTOR NO.	7/16" (11.1mm) OUTSIDE DIA. GUIDE BUSH NO.	5/8" (15.9mm) OUTSIDE DIA. GUIDE BUSH NO. ▼	METHOD OF ATTACHMENT
AEG	OFE 710 in plunge base	No adaptor required	711	716	Screws incl. w/router
	OFSE 2000	703	711	716	♦
ATLAS COPCO	OFE 710 in plunge base, OFE 1000	No adaptor required	711	716	Screws incl. w/router
	OFSE 2000	703	711	716	♦
AXMINSTER WHITE	AW635R	No adaptor required	711	716	Screws incl. w/router
	AW127R	Adaptor supplied w/router	711	716	Screws incl. w/router
BLACK & DECKER	All Professional, HD 1250, RP400K	No adaptor required	711TP	716TP	Threaded nut included
	6200	720673-00	711TP	716TP	2 screws req'd. 249412-20
	SR100, 7AEE, KW780 series	No adaptor required	711	716	Screws incl. w/router
BOSCH	90140, 90098, 90088	No adaptor required	82855	82854	Screws included
	90085, 90150, 90300, 90303, 90305, 91284		82859	82864	Screws included
	1600, 1601, 1602, 1603, 1604, 1606, B1350	2 610 906 290	711TP	716TP	Threaded nut included
	1613, 1613EVS, 1613AEVS, 1614, 1614EVS, 1617, 1617EVS, 1618EVS, 1619EVS, B1450, POF800ACE, GOF900ACE, GOF1300ACE, GOF2000CE	No adaptor required (RA1100 required for VGS)	RA1107	RA1113	No screws required
	1611, 1611 EVS, 1615, 1615 EVS, B1550	702	711	716	♦
	GOF1600, GOF1700ACE				
CASALS	FT750, FT 1000E, FT2000E	703	711	716	♦
CMT	1E	702R	711	716	♦
CRAFTSMAN (SEARS)	All non-plunge models	No adaptor required	Set of 3 bushes from Sears USA order no.25082 (stamped steel) or 25090 (plastic). Set of 3 bushes from Sears Canada order no.092-970-704		Screws incl. w/set
	135275070 Plunge				
	Other plunge models	702	711	716	♦
DEWALT	DW610	No adaptor required	711TP	716TP	Threaded nut included
	DW613	No adaptor required	711	716	Screws incl. w/router
	DW614, DW615, DW621	North America Only	711TP	716TP	Threaded nut included
	DW624, DW625 and DW626	Adaptor supplied w/router			
	DW621K and DW626 outside N. America	706	711	716	♦
	DW625 Type 1, 2 & 3 outside N. America	702	711	716	♦
EINHELL	DW625 Type 4 outside N. America, DW625EK	702R	711	716	♦
	EOF 850 SP, OF-G 1100E	No adaptor required	711	716	Screws incl. w/router
ELU	OF15, OF15E, OF97, OF97E	706	711	716	♦
	MOF68, MOF69, MOF96, MOF96E	No adaptor required	711	716	Screws incl. w/router
	MOF131, MOF177 Type 1, 2 & 3	702	711	716	♦
	MOF177 Type 4, MOF177EK	702R	711	716	♦
	2720, 2721, 3328	No adaptor required	711TP	716TP	Threaded nut included
	3303, 3304	E09600 or 761 270-00	711TP	716TP	Threaded nut included
FEIN	3337, 3338, 3339	702	711	716	♦
	RT1800	Adaptor supplied w/router	711TP	716TP	♦
FESTOOL	OF1E, OF2E, OF650, OF800E, OF1000, OF1010E	704	711TP	716TP	Threaded nut included
	OF2000, OF2000E	705	711	716	♦
FLEX	All	No adaptor required	711TP	716TP	Threaded nut included
FREUD	FT2000	703	711	716	♦
HITACHI	TR8, TR12, FM8, M8, M12 Series	703	711	716	♦
HOLZ-HER	2355, 2356	No adaptor required		716	Screws incl. w/router
	2365	702	711	716	♦
ISKRA	MR808A Series	No adaptor required	711	716	Screws incl. w/router
JEPSON	7412	703	711	716	♦
KANGO	OF808	No adaptor required	711	716	Screws incl. w/router
KRESS	OF690 IE Series	No adaptor required	711	716	Screws incl. w/router
MAPELL	LOG5E	702 ■	711	716	♦
MAKITA	3600, 3606, 3608, 3612, 3612B, 3612BR	703	711	716	♦
	3612C N. America, 3620, 3621				
	3612C Europe Qk. Fit Base	Contact your National Leigh distributor			
	3601B	321 493-1	711TP	716TP	Threaded nut included
METABO	RP0910, RP1110C	706	711	716	♦
	RF1100, RF1101, RD1100, RD1101, RP1101	No adaptor required	711TP	716TP	Threaded nut included
	OF1612, OFE1812	704	711TP	716TP	Threaded nut included
MILWAUKEE	All	No adaptor required	49-54-0520	49-54-0550	Screws included
PERLES	OF808 Series, OFE 6990	No adaptor required	711	716	Screws incl. w/router
PORTER CABLE(Rockwell)	All	No adaptor required	711TP	716TP	Threaded nut included
POWER DEVIL	All	No adaptor required	711	716	Screws incl. w/router
RYOBI	R30, R50, R150, R151, RE155, R161	703	711	716	♦
	R500, R501, R502				
	R600, R601, RE600, RE601	702	711	716	♦
	R160, R165, R170, R175, RE175, R180, R185	706	711	716	♦
SCHEER	HM9, HM14, HM14-12, HM18, HM18-E	No adaptor required ●	711	716	Screws incl. w/router
SKIL	1823 or 1835	91803	711TP	716TP	Threaded nut included
	All others	No adaptor required	11592	71021	Nut 11587
STANLEY	All	See Bosch Distributor			
STAYER	PR50 Series	No adaptor required	711	716	Screws incl. w/router
TREND (FELLISATI)	T5	No adaptor required	711	716	Screws incl. w/router
	T9	Adaptor supplied w/router			
WEGOMA	OF850 Series	No adaptor required	711	716	Screws incl. w/router

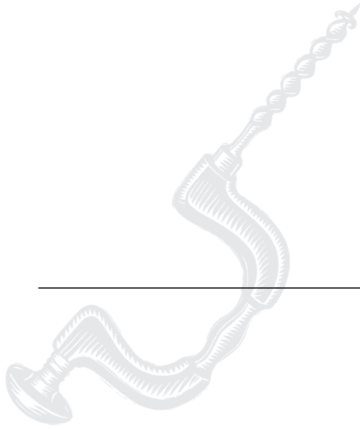

DA! APPENDIX II

Cutter Selection



Appendix II D4 User Guide

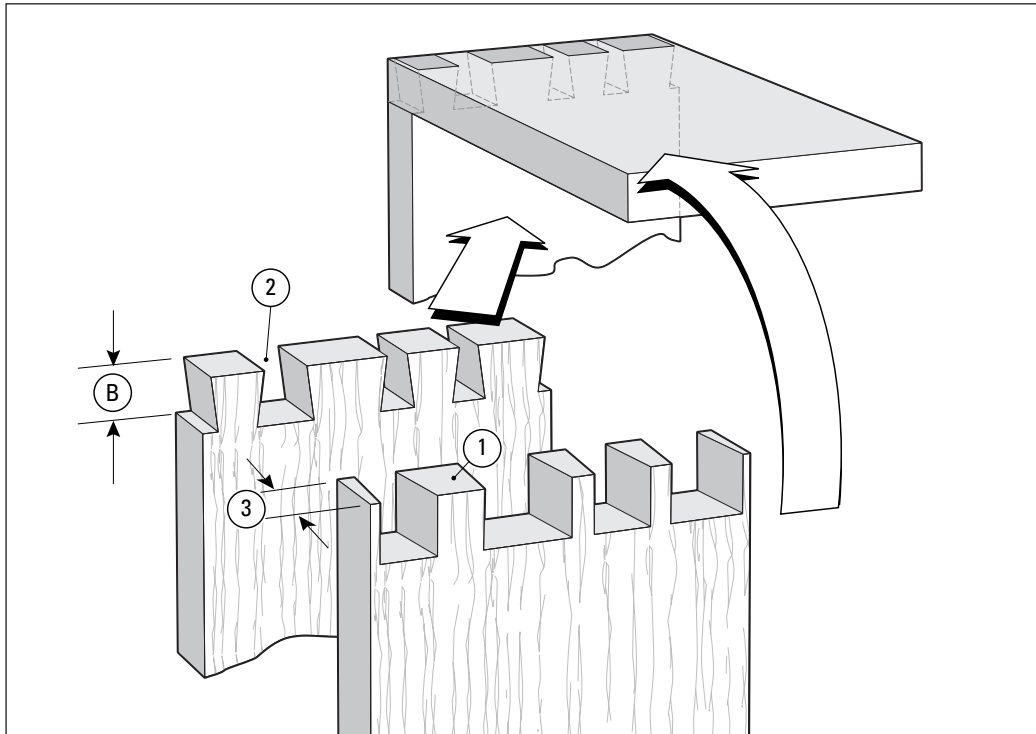

Cutter Selection for Through Dovetails

8° Dovetail Cutter for Tails

The pins ① must fit into the sockets ②. So the dovetail cutter's depth of cut ③ must be equal to or a little greater than the pinboard thickness ③.

Measure the pinboard thickness ③ and select the dovetail cutter with the correct depth of cut ③ from the following pages (cutters must be 8° for through dovetails).

Straight Cutter for Pins

The matching straight cutter is listed just below the dovetail cutters.

Guidebush

The correct diameter guidebush is in the last column of the cutter specifications.

Shank Selection

Note: If your router has an 8mm or larger collet, we highly recommend you use our 8mm shank cutters instead of 1/4" [6,35mm] shanks. For a 1/2" [12,7mm] collet you will require our 1/2" [12,7mm] to 8mm collet adapter No. 172-8. **Note:** This is a collet reducer ④, not a collet ⑤. It does not replace the collet, it slides directly into your 1/2" collet.

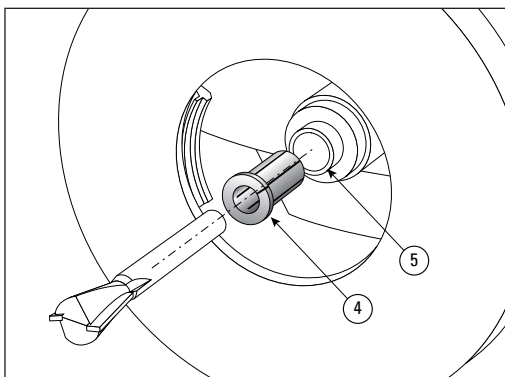

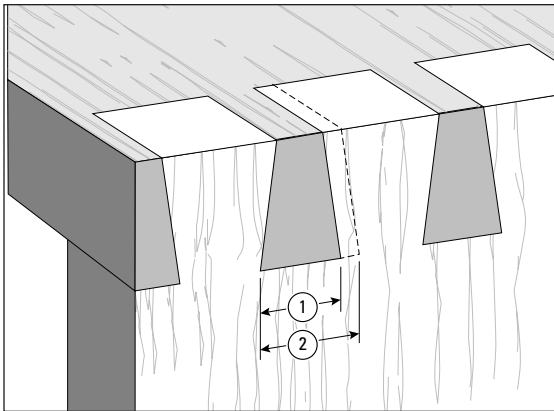

You will note that some of the dovetail cutters' depths of cut overlap. For example:
 No.80 cutter (B): 1/2" - 13/16" [12 - 20mm]
 No.90 cutter (B): 5/8" - 1" [16 - 26mm]

This means that boards between 5/8" and 13/16" [16 - 20mm] thick can be joined using either the No.80 - 140 combination or the No.90 - 160 combination.

The two cutter combinations will produce slightly different-looking joints because the No.80 cutter can cut a narrower pin socket ① than the No.90 cutter ②.



Do not attempt to rout dovetails at less than the minimum depth of cut specified.

Leigh Through Dovetail Cutters

Note: Cutter and joint drawings about 75% actual size.

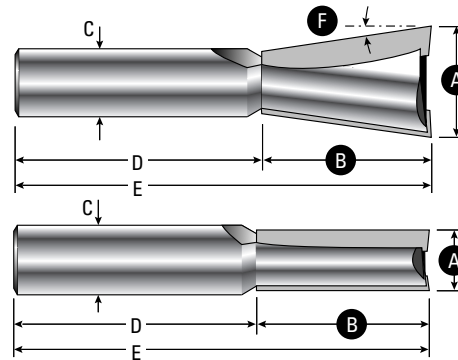
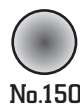
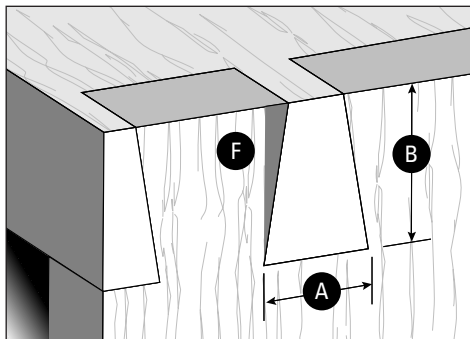

Cutters	A	B	C	D	E	F	Guidebush Diameter
	Overall Diameter	Cutting Depth Range	Shank Diameters	Shank Length	Overall Length	Angle	
No.100	13/16" [20,6]	1" to 1-1/4" [26,0-32,0]	1/2" [12,7]	1-3/4" [45,0]	3" [76,0]	8°	5/8" [159]
No.150	7/16" [11,1]	up to 1-1/4" [32,0]	1/2" [12,7]	1-3/4" [45,0]	3" [76,0]	-	5/8" [159]

Numbers in brackets are millimetres

Appendix II D4 User Guide

Leigh Through Dovetail Cutters

Note: Cutter and joint drawings about 75% actual size.

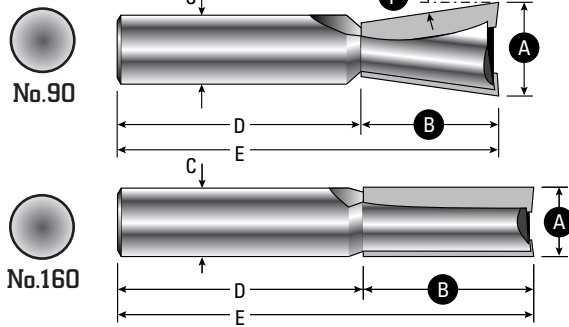
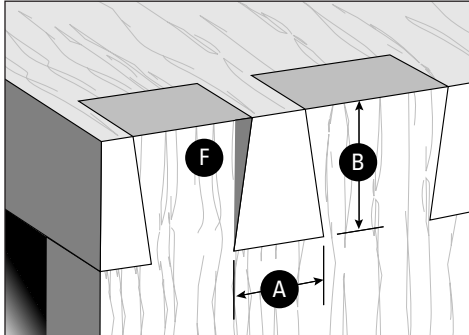

Cutters	A Overall Diameter	B Cutting Depth Range	C Shank Diameters	D Shank Length	E Overall Length	F Angle	Guidebush Diameter
No. 90	11/16" [17,5]	5/8" to 1" [16,0-26,0]	1/2" [12,7]	1-3/4" [45,0]	2-3/4" [70,0]	8°	5/8" [159]
No. 160	1/2" [12,7]	up to 1-1/4" [32,0]	1/2" [12,7]	1-3/4" [45,0]	3" [76,0]	-	5/8" [159]

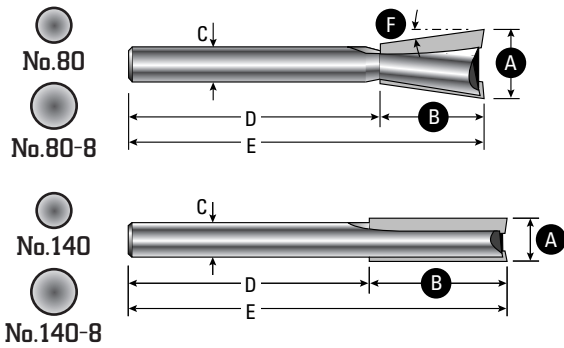
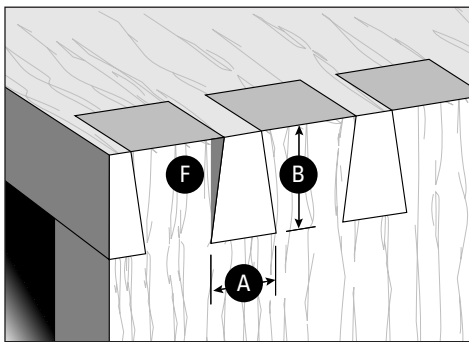

Cutters	A Overall Diameter	B Cutting Depth Range	C Shank Diameters	D Shank Length	E Overall Length	F Angle	Guidebush Diameter
*No. 80	1/2" [12,7]	1/2" to 13/16" [13,0-20,6]	1/4" or 8mm	1-3/4" [45,0]	2-9/16" [65,0]	8°	7/16" [11.1]
*No. 140	5/16" [7,9]	up to 1" [26,0]	1/4" or 8mm	1-3/4" [45,0]	2-3/4" [70,0]	-	7/16" [11.1]

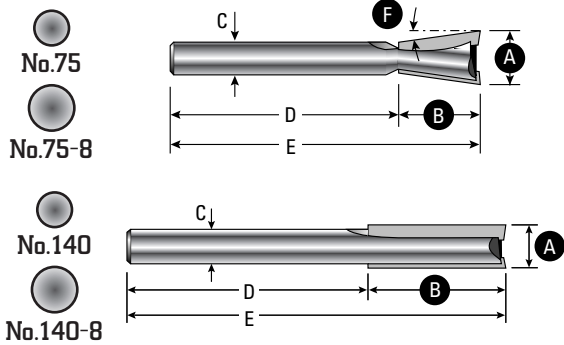
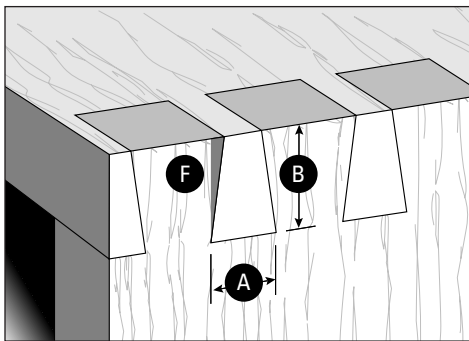

Cutters	A Overall Diameter	B Cutting Depth Range	C Shank Diameters	D Shank Length	E Overall Length	F Angle	Guidebush Diameter
No. 75	7/16" [11,1]	3/8" to 5/8" [9,5-16,0]	1/4" or 8mm	1-3/4" [45,0]	2-3/8" [60,0]	8°	7/16" [11.1]
No. 140	5/16" [7,9]	up to 1" [26,0]	1/4" or 8mm	1-3/4" [45,0]	2-3/4" [70,0]	-	7/16" [11.1]

Numbers in brackets are millimetres

* No.80 and No.140 cutters come standard with the Leigh Jig

Note: Cutter and joint drawings about 75% actual size.

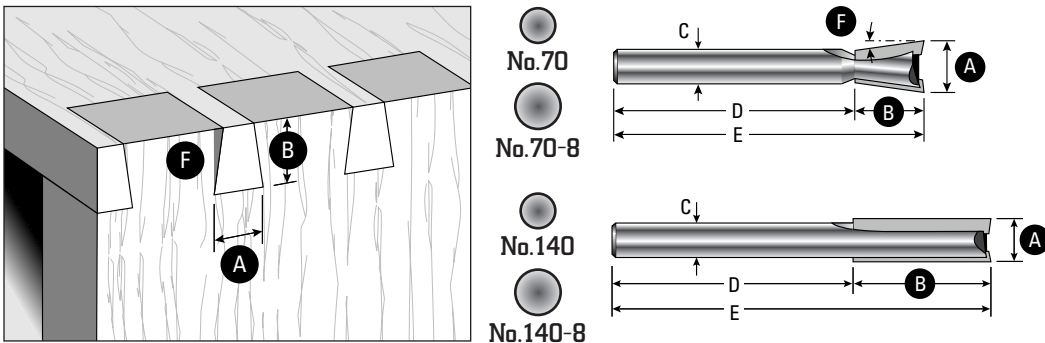

Cutters	A Overall Diameter	B Cutting Depth Range	C Shank Diameters	D Shank Length	E Overall Length	F Angle	Guidebush Diameter
No. 70	3/8" [9,5]	1/4" to 1/2" [6,0-13,0]	1/4" or 8mm	1-3/4" [45,0]	2-1/4" [57,0]	8°	7/16" [11.1]
No. 140	5/16" [7,9]	up to 1" [26,0]	1/4" or 8mm	1-3/4" [45,0]	2-3/4" [70,0]	-	7/16" [11.1]

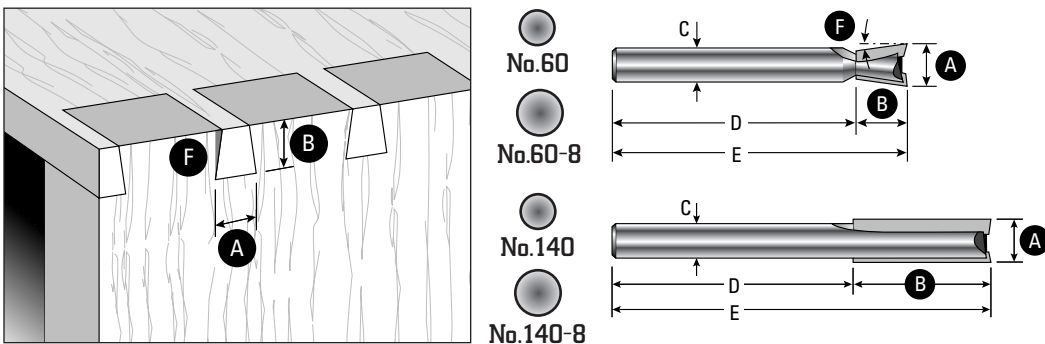

Cutters	A Overall Diameter	B Cutting Depth Range	C Shank Diameters	D Shank Length	E Overall Length	F Angle	Guidebush Diameter
No. 60	5/16" [7,9]	up to 3/8" [9,5]	1/4" or 8mm	1-3/4" [45,0]	2-1/8" [54,0]	8°	7/16" [11.1]
No. 140	5/16" [7,9]	up to 1" [26,0]	1/4" or 8mm	1-3/4" [45,0]	2-3/4" [70,0]	-	7/16" [11.1]

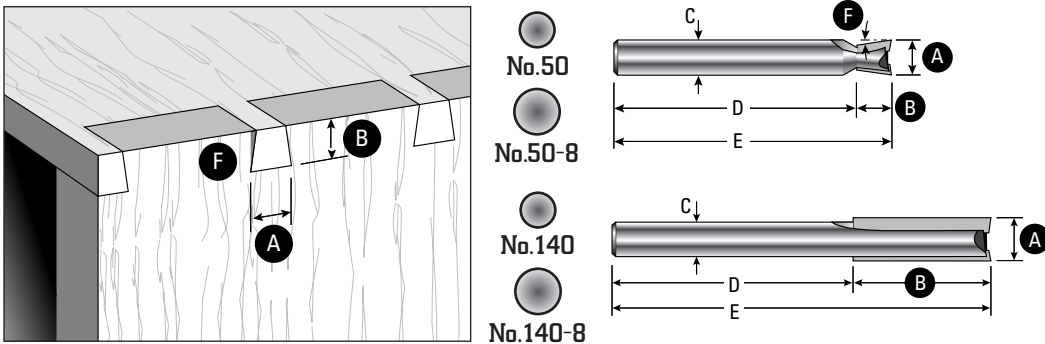

Cutters	A Overall Diameter	B Cutting Depth Range	C Shank Diameters	D Shank Length	E Overall Length	F Angle	Guidebush Diameter
No. 50	1/4" [6,35]	up to 1/4" [6,35]	1/4" or 8mm	1-3/4" [45,0]	2" [50,0]	8°	7/16" [11.1]
No. 140	5/16" [7,9]	up to 1" [26,0]	1/4" or 8mm	1-3/4" [45,0]	2-3/4" [70,0]	-	7/16" [11.1]

Numbers in brackets are millimetres

Appendix II D4 User Guide

Half-Blind Dovetails

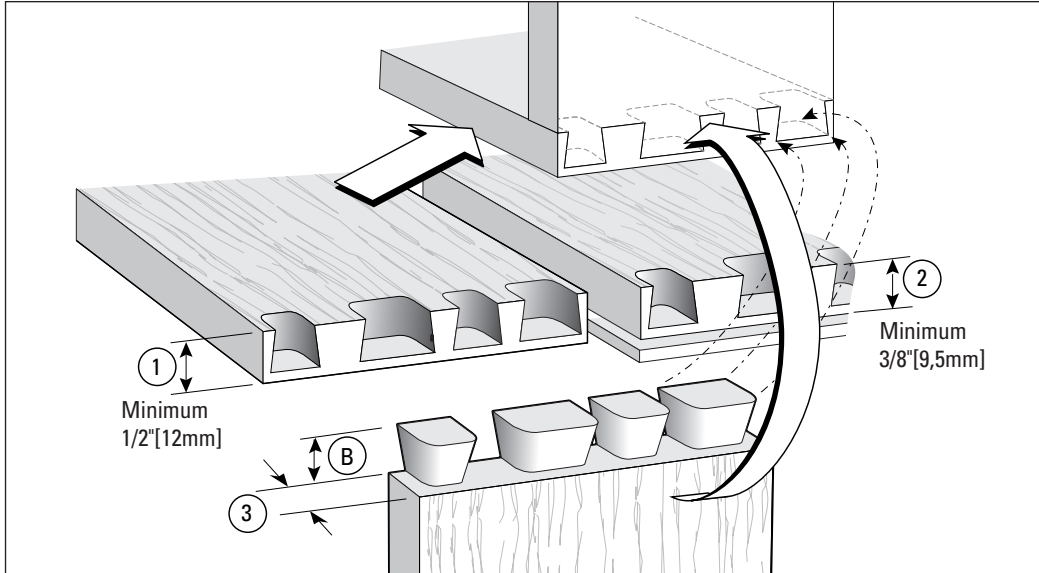
**Cutter Selection for Half-Blind Dovetails**

Both parts of a half-blind dovetail are cut with the same dovetail cutter. The dovetail cutter's working depth of cut \textcircled{B} must be less than the pinboard thickness $\textcircled{1}$ for flush drawers by at least $\frac{1}{8}$ " [2mm], and slightly less than the rabbet depth $\textcircled{2}$ for rabbeted drawer fronts. Minimum pin board (drawer front) thickness is $\frac{1}{2}$ " [12mm].

Drawer side thickness $\textcircled{3}$ does not affect cutter selection.

Note: \textcircled{B} is the nominal working depth for half-blind dovetails, not the maximum depth. \textcircled{B} must not be varied, except for minor adjustments for joint fit. See page 82.

Measure the drawer front thickness (minimum $\frac{1}{2}$ " [12mm]) $\textcircled{1}$ or rabbet depth (minimum $\frac{3}{8}$ " [9,5mm]) $\textcircled{2}$ and select the cutter with the appropriate depth of cut \textcircled{B} from one of the four cutters on the following pages.

Guidebush

The correct diameter guidebush is in the last column of the cutter specifications.

Shank Selection

Note: If your router has an 8mm or larger collet, we highly recommend you use our 8mm shank cutters instead of $\frac{1}{4}$ " [6,35mm] shanks. For a $\frac{1}{2}$ " [12,7mm] collet you will require our $\frac{1}{2}$ " [12,7mm] to 8mm collet adapter No. 172-8. **Note:** This is a collet reducer $\textcircled{4}$, not a collet $\textcircled{5}$. It does not replace the collet, it slides directly into your $\frac{1}{2}$ " collet.

All half-blind dovetails on the D4 are routed with a $\frac{7}{16}$ " OD guidebush. See page 151.

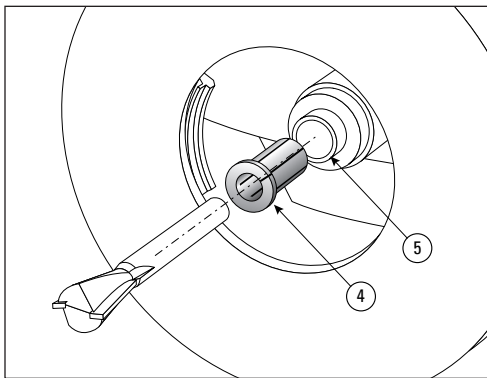

Leigh Half-Blind Dovetail Cutters

Note: Cutter and joint drawings about 75% actual size.

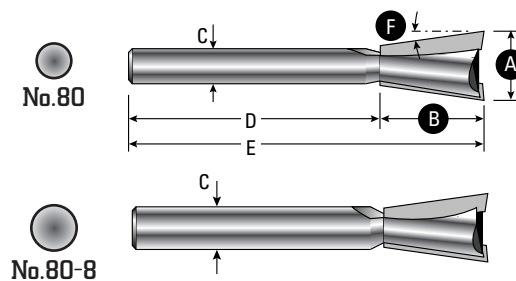
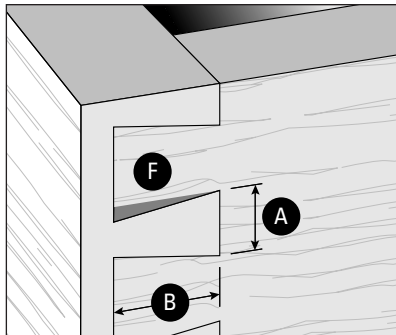

Cutters	A Overall Diameter	B Working Depth	C Shank Diameters	D Shank Length	E Overall Length	F Angle	Guidebush Diameter
*No. 80	1/2" [12,7]	~3/4" [19]	1/4" or 8mm	1-3/4" [45,0]	2-9/16" [65,0]	8°	7/16" [11.1]

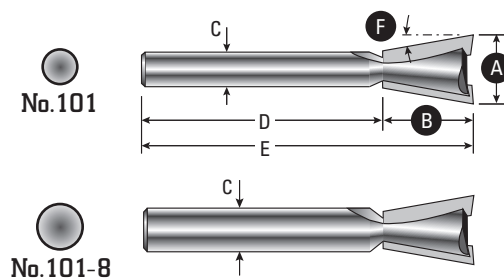
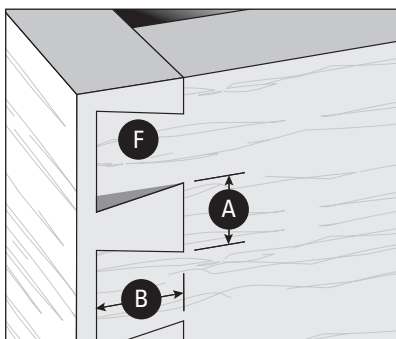

Cutters	A Overall Diameter	B Working Depth	C Shank Diameters	D Shank Length	E Overall Length	F Angle	Guidebush Diameter
No. 101	1/2" [12,7]	~5/8" [16,0]	1/4" or 8mm	1-3/4" [45,0]	2-3/8" [60,0]	10°	7/16" [11.1]

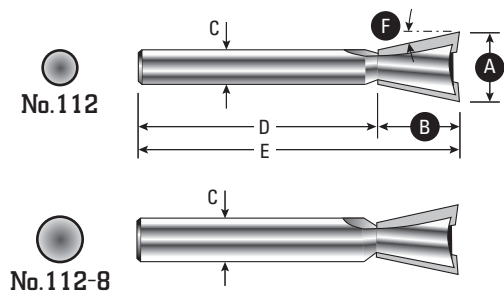
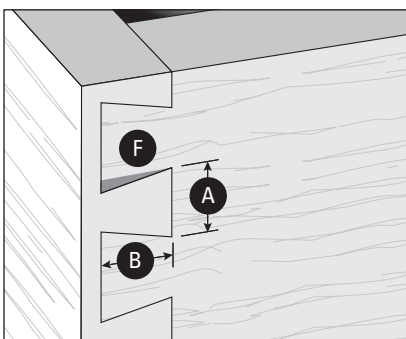

Cutters	A Overall Diameter	B Working Depth	C Shank Diameters	D Shank Length	E Overall Length	F Angle	Guidebush Diameter
No. 112	1/2" [12,7]	~1/2" [13,0]	1/4" or 8mm	1-3/4" [44,0]	2-21/64" [59]	12°	7/16" [11.1]

Numbers in brackets are millimetres

* No.80 cutter comes standard with the Leigh Jig

Appendix II D4 User Guide

Note: Cutter and joint drawings about 75% actual size.

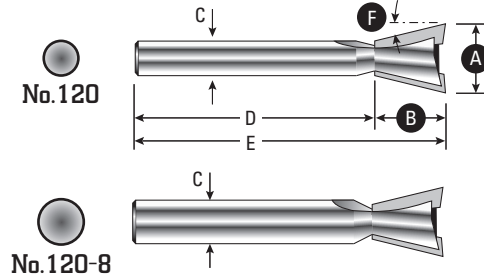
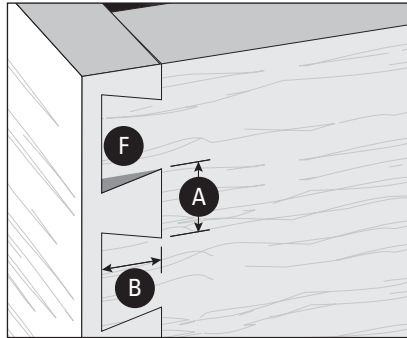

Cutters	A Overall Diameter	B Working Depth	C Shank Diameters	D Shank Length	E Overall Length	F Angle	Guidebush Diameter
No. 120	1/2" [12,7]	~7/16" [11,0]	1/4" or 8mm	1-3/4" [45,0]	2-1/4" [57]	14°	7/16" [11.1]

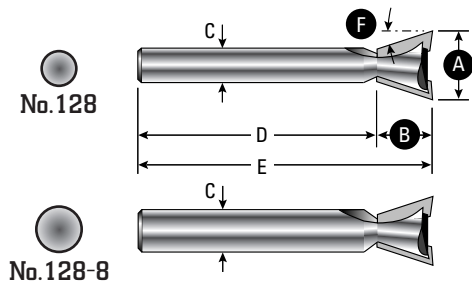
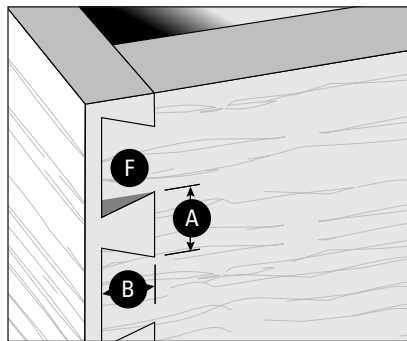

Cutters	A Overall Diameter	B Working Depth	C Shank Diameters	D Shank Length	E Overall Length	F Angle	Guidebush Diameter
No. 128	1/2" [12,7]	~3/8" [9,5]	1/4" or 8mm	1-3/4" [45,0]	2-1/8" [54,0]	18°	7/16" [11.1]

Numbers in brackets are millimetres

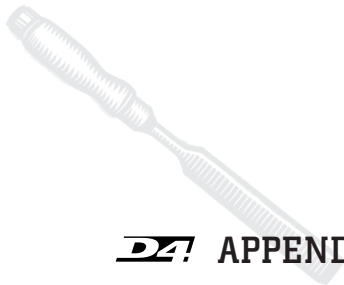
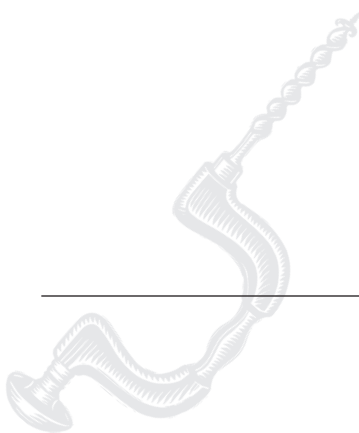

DA APPENDIX III

Jig Parts List

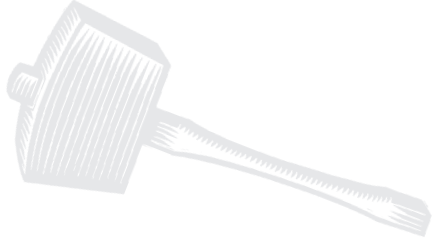

Appendix III D4 User Guide

PART NO.	QUANTITY		PART DESCRIPTION
	PER JIG		
22	1		VHS Instructional Video (english - inch only)
24	1	*	User Guide D4 (English–Inch/Metric)
80	1	*	Dovetail Cutter, 1/4" shank
or 80-8	1	*	Dovetail Cutter, 8mm shank
140	1	*	Straight Cutter, 1/4" shank
or 140-8	1	*	Straight Cutter, 8mm shank
211	2		Front Body Extrusion, Rear Body Extrusion
231	1		R.H. End-Housing
241	1		L.H. End-Housing
251	1		Body Cover
260	8		End-Housing Screws
270	6		Clamp Bar T-Bolts, Jig Hold Down T-Bolts
283	7		Flat Washers for Side Stops and Jig Hold Down Bolts
284	2		Angle Side-Stop Square Nuts
286	1		Angle Side-Stop Bolt
287	1		Accessory attachment screw
291	2		R.H. Side Stop complete with Bumpers, Screws and Washers
292	2		L.H. Side Stop complete with Bumpers, Screws and Washers
293	8		Side Stop Bumpers
294	8		Side Stop Bumper Screws
295	8		Side Stop Bumper Lockwashers
300	6		Clamp Bar Bolt Nuts, Hold Down Bolt Nuts
311	4		Clamp Bar Springs
331	1		Front Clamp Bar (complete with End Plugs 803)
333	1		Rear Clamp Bar (complete with End Plugs 803)
370	2		Support Bracket Knobs
371	2		Support Bracket Knob Washers (nylon)
392	1	*	R.H. Inch Scale Assembly, complete (R.H. in H.B. Tail Mode)
or 392M	1	*	R.H. Metric Scale Assembly, complete (R.H. in H.B. Tail Mode)
394	1	*	L.H. Inch Scale Assembly, complete (L.H. in H.B. Tail Mode)
or 394M	1	*	L.H. Metric Scale Assembly, complete (L.H. in H.B. Tail Mode)
422	2	*	Cross Cut Bar Caps
431	1	*	Cross Cut Bar
441	1	*	H.B. Pin Guide Rail
451	1	*	Finger Guide Rail
461	13	*	R.H. Finger complete with Wedge, Nut and Screw
471	13	*	L.H. Finger complete with Wedge, Nut and Screw
481	26	*	Finger Wedges
491	26	*	Finger Nuts
501	26	*	Finger Lock Screws
540	1		Leigh Assembly Wrench/Gauge/Angle Side Stop
550	1		Finger Adjusting Screwdriver
620	1		R.H Support Bracket
630	1		L.H. Support Bracket
660	2	*	Scale Lock Screws
801	4		Cam-Action Speed-Clamps complete with Step Washers 802
802	4		Speed-Clamp Step Washers
803	4		Clamp Bar End Plug

* Parts marked with an asterisk are also the parts list for Leigh D4A Dovetail Finger Assembly; models D4A, D4A-8, D4A-M and D4A-M/8.

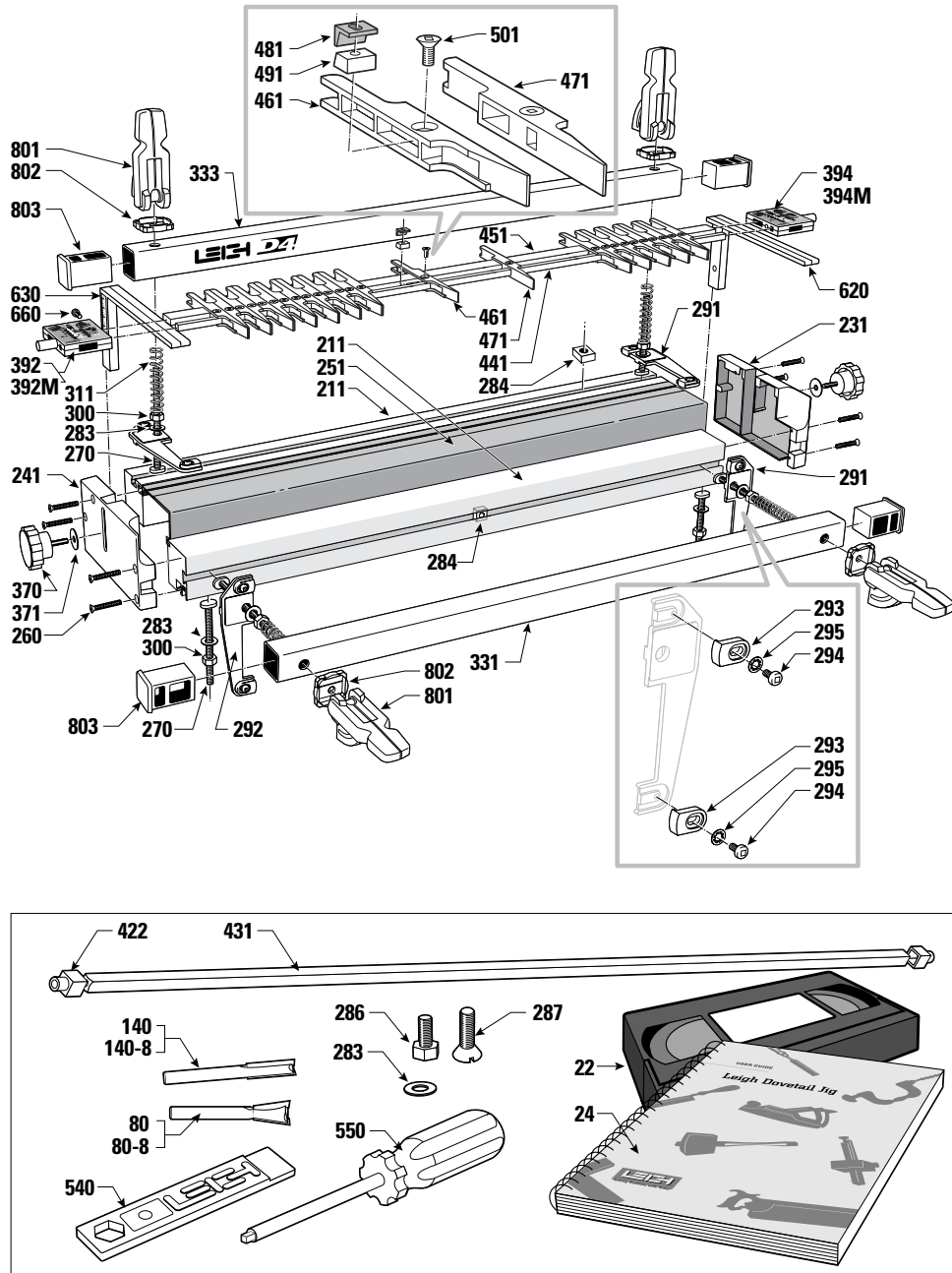

NOTE: When ordering parts, please quote the jig model, serial number, part number, part description and quantity required. Pay particular attention to the scale measurement, inch or metric.

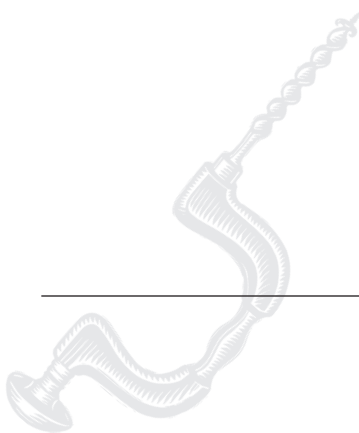

 APPENDIX IV

Customer Support

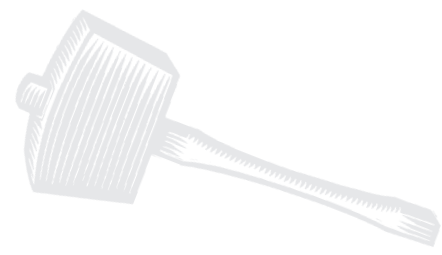

*Appendix IV D4 User Guide***Our Commitment to You**

At Leigh Industries we take pride in our commitment to provide excellence in customer service and support. We hope your use of the Leigh D4 will be enjoyable, rewarding, and most of all, trouble free. We hope this User Guide

will provide you with the answers to any questions you may have.

If this is not the case, please feel free to contact our technical support staff or our distributor in your country by any of the means listed below.

Canada & USA**Manufacturer**

Leigh Industries Ltd. (EST. 1981)
P.O. Box 357,
(1615 Industrial Ave.,)
Port Coquitlam, B.C.,
Canada, V3C 4K6

Toll Free: 1-800-663-8932
Telephone: (604) 464-2700
Facsimile: (604) 464-7404
*E-mail: leigh@leighjigs.com
Tech Support: help@leighjigs.com
Website: www.leighjigs.com

*Email can be useful, but technical queries usually raise queries from us. So the telephone (if possible) is a much quicker and more convenient way to get those queries answered; either directly to Leigh (toll-free in North America) or to your national distributor. ...Thanks!

Distributors**United Kingdom & Eire**

BriMarc Associates
7-8 Ladbroke Park
Millers Road
Warwick, England
CV34 5AN
Phone: 01926 493 389
Fax: 01926 491 357
Web: www.brimarc.com

Norway

Helge Ovedal
Freseteknikk
4440 Tonstad
Norway
Phone: 00 47 38 37 16 36
Fax: 00 47 38 37 16 34
Email: helge@ovedal.com
Web: www.freseteknikk.com

Germany, Austria & Switzerland

Hacker GMBH
Holzbearbeitungsmaschinen
Traberhofstrasse 103
83026 Rosenheim
Bavaria, Germany
Telephone: 08031-26 96 50
Facsimile: 08031-68 22 1
Website: www.leigh.de

Australia & New Zealand

Mik International
Box 70 Burnside SA 5066
27 Magill Road, Stepney, SA
5069
Australia
Telephone: (08) 8363 4666
Facsimile: (08) 8362 3444
E-mail: inquiries@mik.com.au
Web: www.mik.com.au

South Africa

Hardware Centre Group
PO Box 4059
Johannesburg/Randburg 2125
Telephone: (011) 791-0844/49
Facsimile: (011) 791-0850

Sweden

Toolbox Sweden AB
Horla Heden 1
SE 441 93 Alingsås, Sweden
Phone: 46-322-670 440
Fax: 46-322-670 449
Email: info@toolboxsweden.se
Web: www.toolboxsweden.se



Joining Tradition with Today

LEIGH INDUSTRIES LTD.

*Manufacturers of Precision
Woodworking Tools*

PO Box 357

(1615 Industrial Ave.)

Port Coquitlam, BC

Canada V3C 4K6

© 1995 Leigh Industries Ltd. All rights reserved.
No part of this publication may be reproduced,
stored in a retrieval system, or transmitted in any
form or by any means, electronic, mechanical,
recording, or otherwise, without the prior written
permission of Leigh Industries Ltd. 06/04