

# LEIGH M2 User Guide

**Multiple Mortise & Tenon Attachment**  
for the D4R Pro Dovetail Jig  
and all earlier model D-series jigs

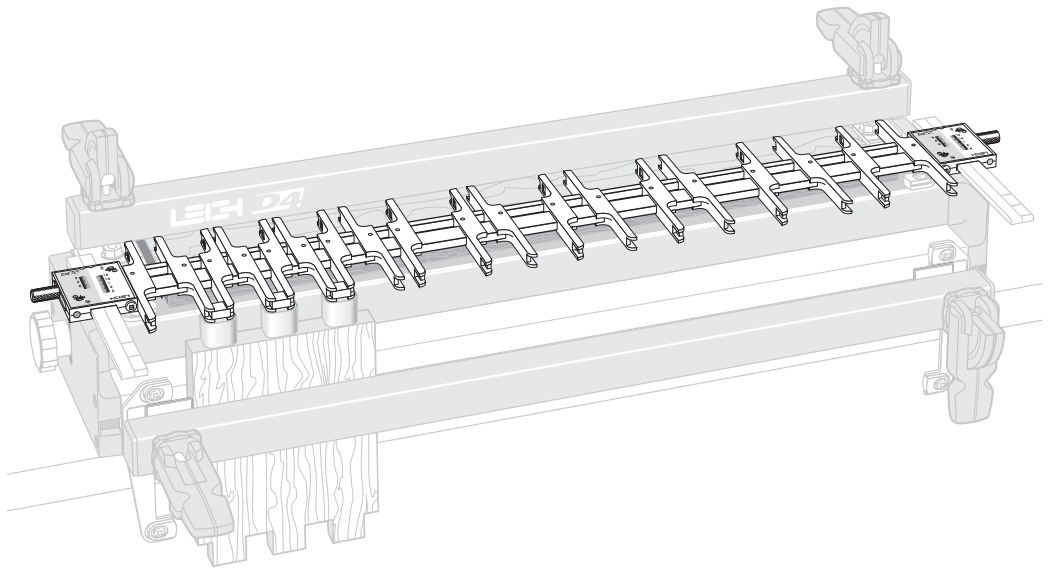

Dedicated Customer Support  
**1-800-663-8932**

**LEIGH**

## Your New Leigh M2 Attachment

Congratulations! You now own the world's only jig for routing multiple mortise and tenon joints; one of the most difficult joints to hand-cut is made simple with the M2.

The M2 is an optional attachment for the Leigh Dovetail Jigs: 24" [610mm] models D1258, D1258R, D3, D4, D4R and D4R Pro.

**Most illustrations in this guide show the M2 mounted on the D4 jig but the instructions are identical for the D4R Pro and all earlier D-series jigs.**

We recommend that you first mount the M2 on your Leigh Jig, carefully following the instructions in the first section of this user guide. Then read the rest of the user guide, following along with the basic functions and principles of operation before you try to do any actual joinery routing. By all means, cut a few practice joints in scrap boards before you use the M2 to rout a precious workpiece!

If you have any questions that are not answered in the user guide, please call the Leigh customer support line.\*

\*See Appendix III – Customer Support

## Important: Inches and Millimeters

Leigh makes the M2 attachment in two models; inch or metric. Text and illustrations in this Leigh English-language user guide indicate dimensions in both inches and millimeters. Dimensions are indicated in text and illustrations with inches first, followed by millimeters in square brackets.

Example:  $\frac{3}{4}$ " x  $5\frac{1}{2}$ " x 8" [20 x 140 x 200mm]

**Do not be concerned if the inch/millimetre equivalents are not always exact.** Just use the dimensions which apply to your jig.

Where finger assembly or template scales overlay an illustration, the inches scale ① will be at the top, the millimeters scale ② will be at the bottom. Only the right "active" half of the scales are illustrated. Setting positions are indicated in this guide with a red line. **On the jig, the lines are black.** General views of the scales ③ will usually show inch markings.

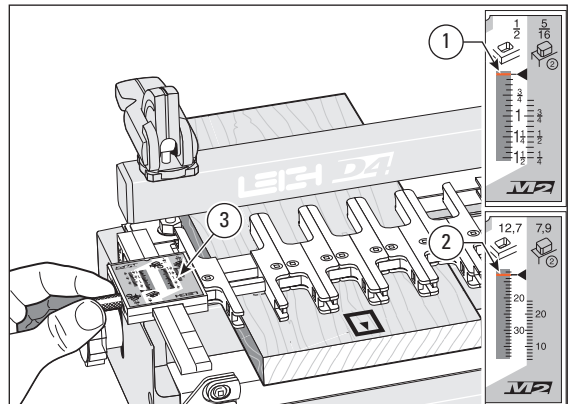

---

Glossary of Symbols .....	iv
CHAPTER 1 – Assembly and Mounting .....	1
CHAPTER 2 – Using Your Attachment Safely.....	7
CHAPTER 3 – Adjusting the Finger Assembly.....	13
CHAPTER 4 – How Routers with Guidebushes Work .....	19
CHAPTER 5 – Basic Jig Functions.....	23
CHAPTER 6 – Wood Preparation .....	31
CHAPTER 7 – The Multiple Mortise and Tenon Joint.....	35
CHAPTER 8 – Operations Procedures for Mortises .....	39
CHAPTER 9 – Operations Procedures for Tenons.....	49
CHAPTER 10 – Beyond the Basics .....	59
Appendix I – Guidebush and Cutter Selection .....	63
Appendix II – Parts List.....	69
Appendix III – Customer Support.....	73

### How to Read the Symbols

To help you understand the instructions and illustrations in this user guide, we have used a number of international symbols, plus a few special ones of our own. They are all explained below. You needn't worry about memorizing these symbols now, because they are repeated quite frequently in the user guide, and you will soon get used to them.

### Glossary of Symbols

The Leigh M2 Attachment can be in any one of three modes, depending on what part of the joint is being routed. Each finger assembly scale has its own mode icon, identifying that joint part. You will also find the mode icon in the top left hand corner of most illustrations, indicating which finger assembly mode to use. Sometimes a mode icon will be used to identify a board.

### Mode and Scale Icons



**Mortises**



**Tenon ① (first side of tenons)**



**Tenon ② (second side of tenons)**

## Which Way Round Should the Board Go?

In nearly all the illustrations we have indicated which side of the board faces you when it is in the jig, e.g., this tenon board ① can face either inward or outward  on the finished piece.



This indicates the side of the board that will face outward on the finished project.



This indicates the side of the board that will face inward on the finished project.



This indicates a side that can face either inward or outward on the finished project.

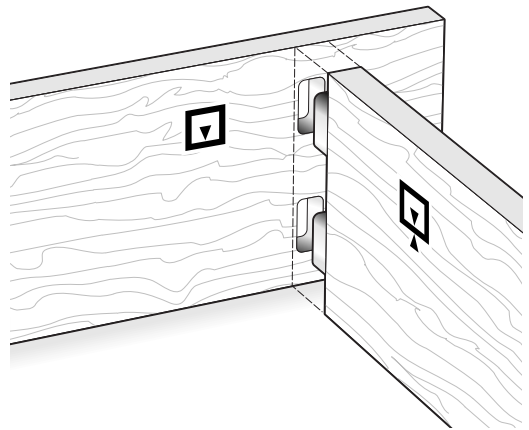
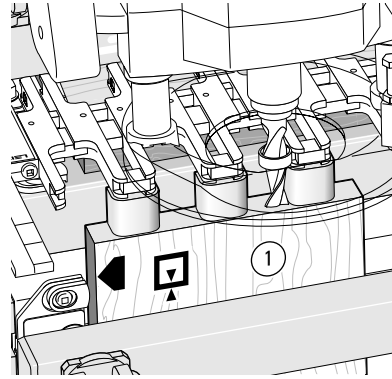

The following symbols indicate:



Left side of item (drawer, box, case, etc.)



Right side of item



Top of item



Bottom of item



This edge against side stop



This edge against side stop



Sawcut allowance



Caution: use special care for this operation

①②③ Reference in text



Diameter



Centreline of board or layout



Equals



Does not equal



Approximately



Less than or equal to



Greater than or equal to



*M2 – CHAPTER 1*

---

# **Assembly and Mounting**

**Make Sure You Have All The Parts!**

Before you start to assemble your Leigh M2, check to make sure you have received all the required parts.

*The carton contains:*

1. 1 finger assembly on two bars  
(10 pairs of fingers)
2. 2 scale assemblies for guidefingers
3. 1 fence assembly complete with two end plugs
4. 2 scale assemblies for fence
5. 2 support brackets\*
6. 1 standard cutter, 1/2" [12,7mm] spiral upcut
7. 1 Leigh M2 user guide
8. 2 side stop extensions
9. 5/64" hex key (2mm may also work)

*If any of these items are missing from your jig, please notify your supplier or Leigh Industries immediately.*

\*D4, D4R and D4R Pro jigs already have these brackets, so these become spares.

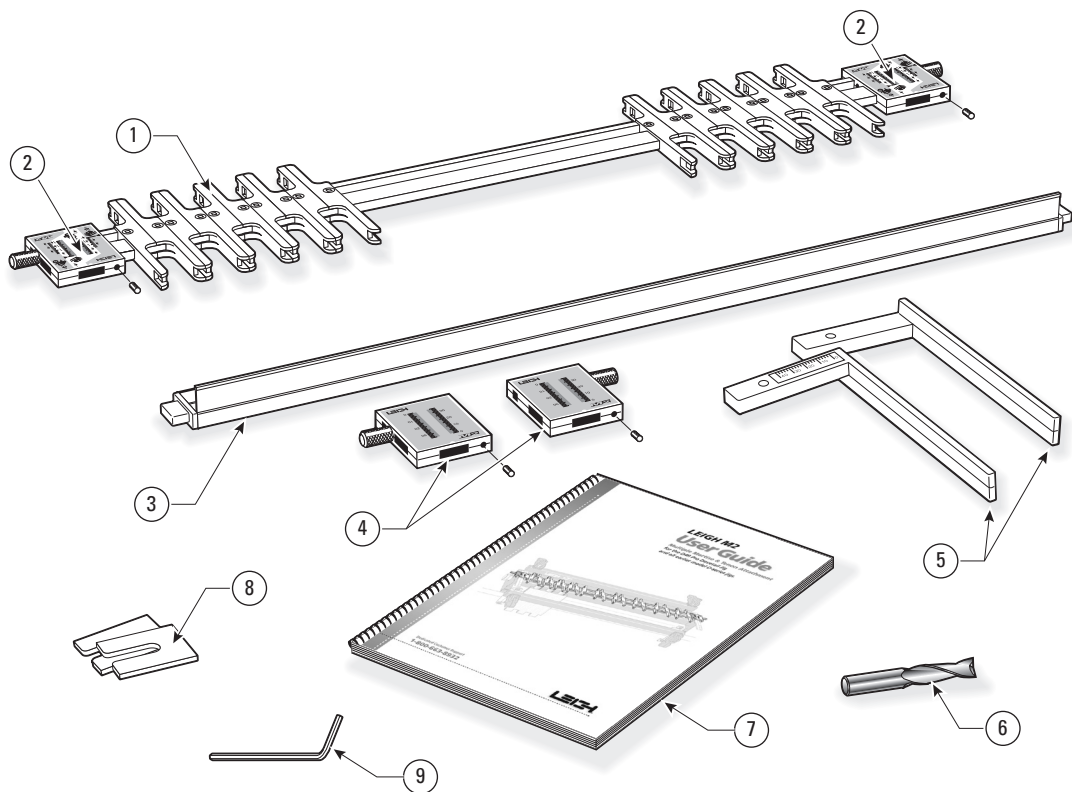

Note: Most illustrations in this guide feature the D4 model jig.

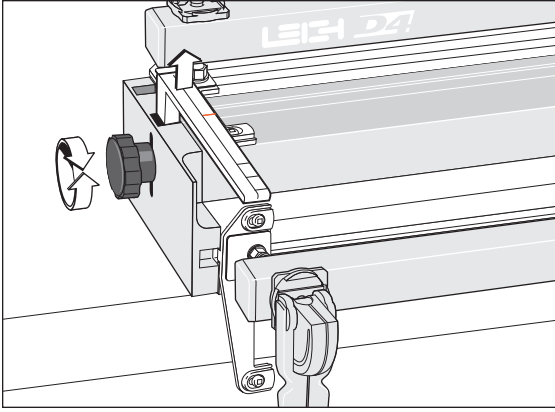

### 1-1

**D1258, D1258R, and D3 jig owners:** Replace the short support brackets with the extended M2 brackets. These are marked LH to left, RH to right. Raise to full height and tighten the knobs. Use these new extended brackets for all dovetailing or template jointing functions.

**D4 and D4R jig owners:** your M2 attachment may come with the extended support brackets. Put these in your “spares” box. Raise the support brackets to full height and tighten the knobs.

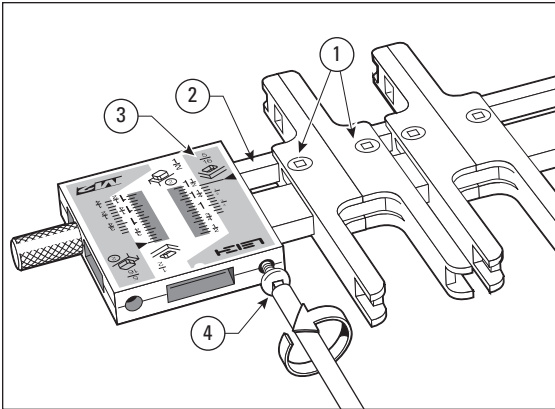

### 1-2

Place the finger assembly on a bench with finger screws ① upwards and the small square bar ② away from you, and the  $\frac{5}{16}$ " [7,9mm]  mortise scale-③ to the right at both ends. Loosen the scale screws ④\*.

**\*M2 scale change:** The original flat head screws on M2 scales have been replaced with set screws and an included hex key.

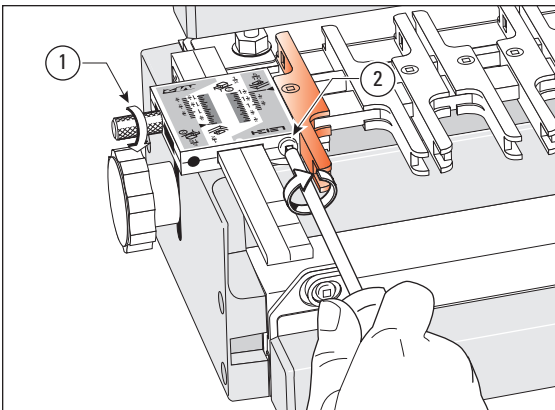

### 1-3

Slide complete finger assembly with *loose* scales onto support brackets. Set scales at say,  $\frac{3}{4}$ " [20mm] on the  $\frac{5}{16}$ " [7,9mm]  mortise scale and tighten thumb screws ①. Now tighten scale lock screws ② firmly with Leigh screwdriver. Do not over-tighten. *To ensure correct alignment, follow this same procedure whenever scales are removed from finger assembly.*

Move the outer finger on both ends out to touch the scales (shown in red).

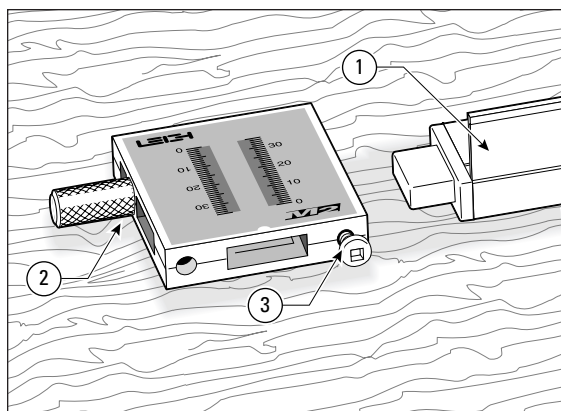
**1-4**

Place fence extrusion flat down on bench with fence ① upright and towards you. Slide tongue into left hand fence scale as shown, with brass thumb screw ② outward and away from you. Repeat for the right hand scale but **do not tighten fence scale lock screws ③ yet**.

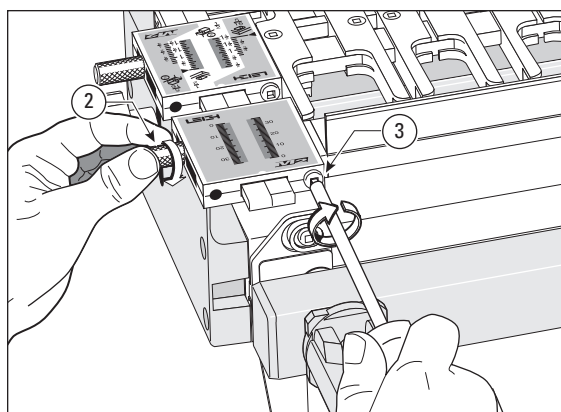
**1-5**

Slide complete fence assembly with loose beam scales onto support brackets. Set scales to the same reading at both ends and tighten brass thumb screws ②. Now tighten scale lock screws ③ firmly with Leigh screwdriver. Do not over-tighten. *To ensure correct alignment, follow this same procedure whenever scales are removed from fence.*

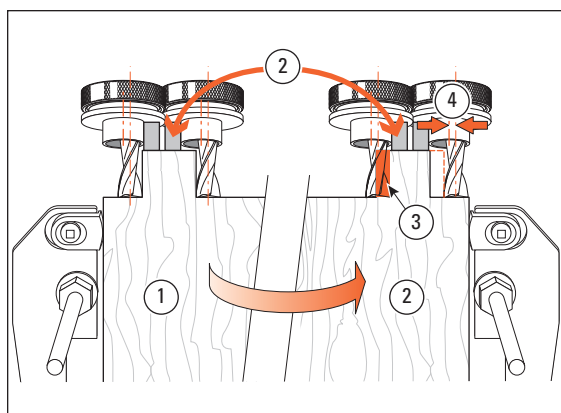
**1-6**

Using the M2 requires a small modification to your Leigh jig. Multiple tenons are routed in two separate stages at both ends of the jig: first on the left ① and then, with the finger assembly and tenon board flipped end-for-end, on the right ②. In this second position it is impossible to guarantee perfect indexing between the guide fingers, side stops and partly formed tenons ③. This is mainly caused by the cutter not being concentric to the guidebush ④ (greatly exaggerated in this illustration).

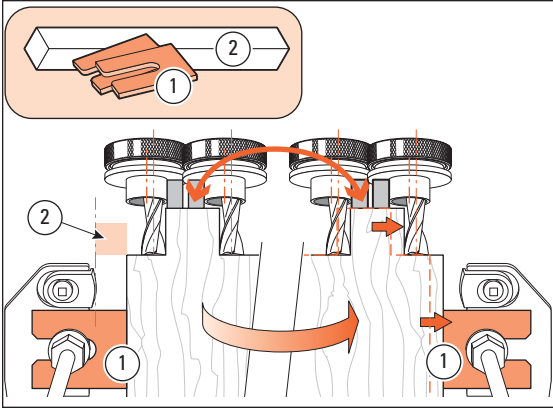
**1-7**

To solve this problem and correctly index the side stops, we have provided two metal sidestop extensions ①. To complete the modification, you will also need to cut a simple ½" [12mm] square by 5" [125mm] long wood "mortise block" ②. The block and extensions will allow adjustment to compensate for any cutter to guidebush eccentricity. The procedure is explained later in this guide.

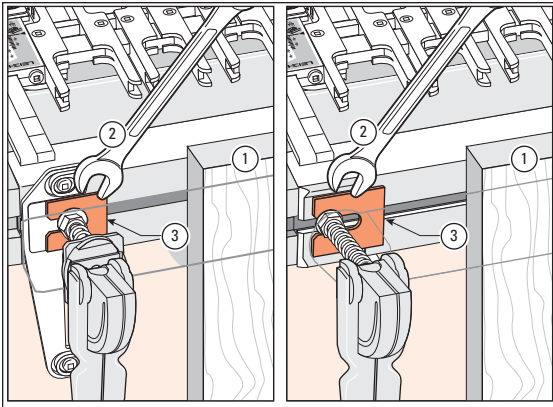
**1-8**

To install the extensions, lightly clamp a board in the front clamp centre ①. This will maintain tension on the clamp bolts and keep them in position while you attach the extensions. Use a ½" [13mm] open end wrench to loosen the two front clamp bolt nuts ② sufficiently to slide the extensions beneath the washers. **Lightly tighten the nuts for now ③.**

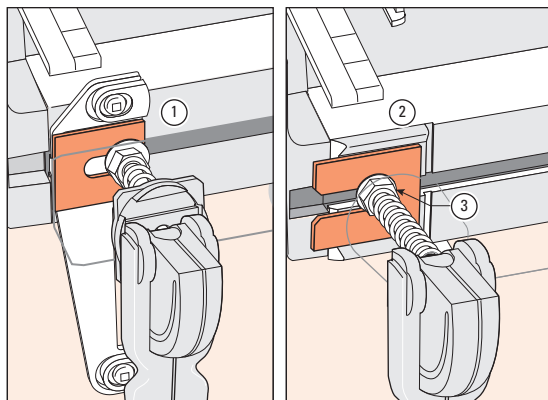
**1-9**

When you're not using the jig with the M2: On the D4 and D3 jigs turn the extensions outward ①.

On the D4R and D4R Pro jig, the extensions can be retracted ②.

Always tighten the clamp nuts ③ after setting or retracting the extensions.

*M2 – CHAPTER 2*

---

# **Using Your Attachment Safely**

**Chapter Foreword****Safety is not optional.**

Read and follow the recommendations in this chapter.

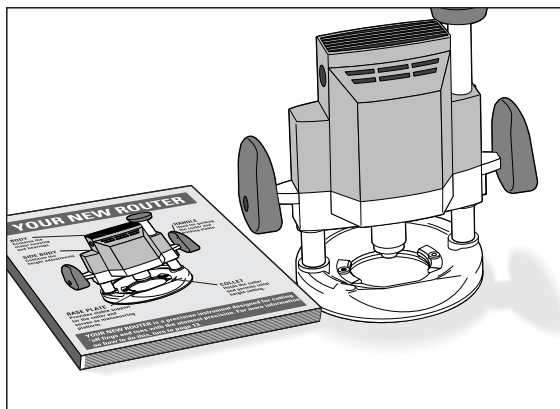

**2-1**  
Read the user guide that came with your router. It is essential to understand the router manufacturer's instructions completely.



**2-2**  
Always wear hearing protection when using a router.

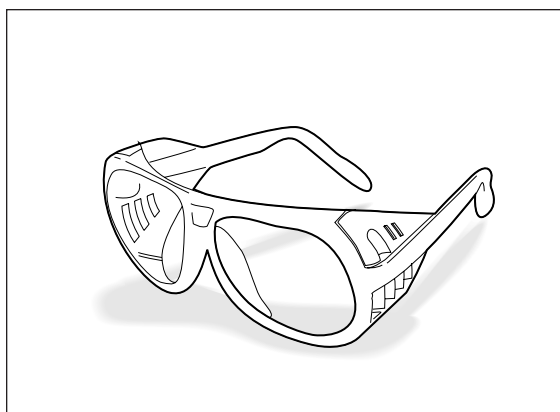

**2-3**  
Always wear approved safety glasses when using a router.

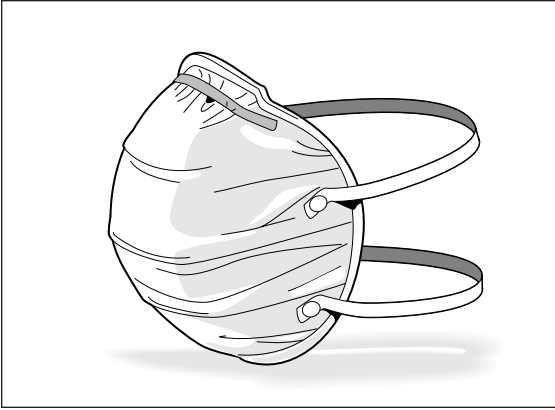
**2-4**

Protect yourself from harmful dust by wearing a face mask.

**2-5** 

Never drink alcohol or take medications that may cause drowsiness when you will be operating a router.

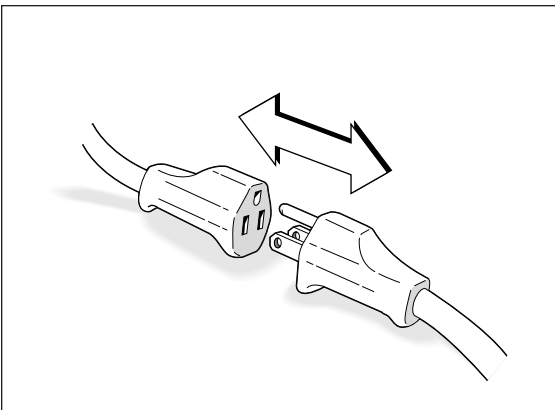
**2-6**

Always disconnect the power source from the router when fitting cutters or guide-bushes, or making adjustments.

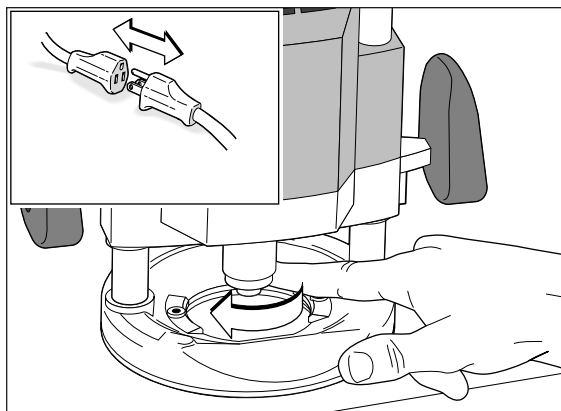
**2-7**

Before connecting the router to the power source, make sure the cutter and collet revolve freely in all the areas you plan to rout, and the cutter does not touch the guidebush or jig.

**2-8** 

Do not tilt the router on the jig.

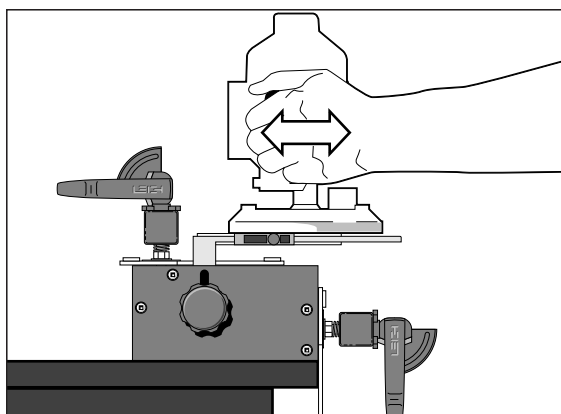
**2-9**

Keep the router flat on the jig assembly.

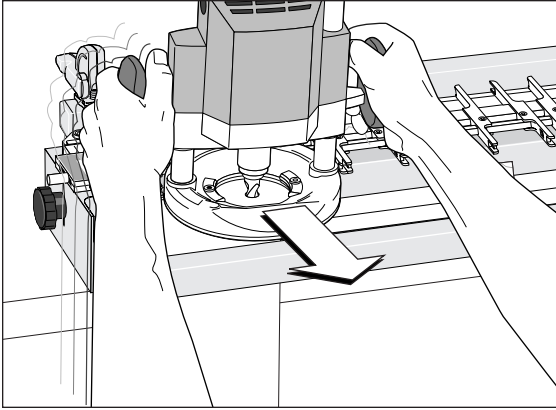
2-10 

If you insist on removing the router from the jig while it is still revolving, always pull it straight off the jig horizontally, and do not raise or lower the router until it is completely clear of the jig.

An obvious exception is while routing mortises, which requires the plunge mechanism to be raised before removing the router.

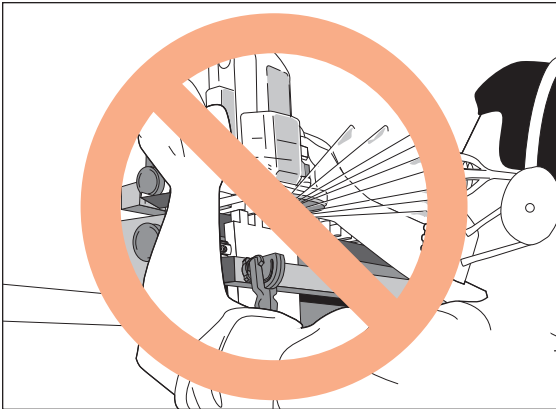
2-11 

Do not rout at face level.

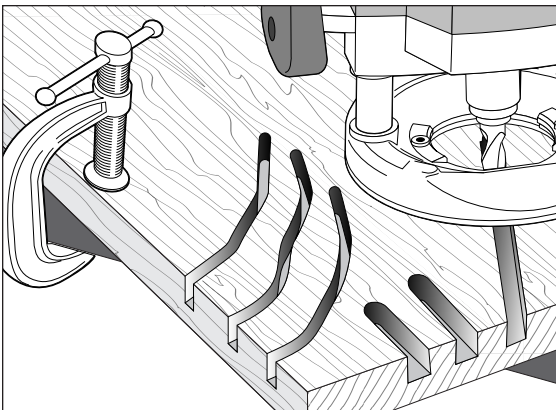
2-12 

If you have never used your router before, be sure to follow the router manufacturer's instructions for its use. Make plenty of simple open-face practice cuts *without a guidebush* before you try to use the router on the Leigh Jig. You must, of course, always use a guidebush when routing on the Leigh M2.

*M2 – CHAPTER 3*

---

# **Adjusting the Finger Assembly**

**Chapter Foreword**

The finger assembly is the heart of the Leigh-M2. Spend a few minutes now to familiarize yourself with these simple adjustments.

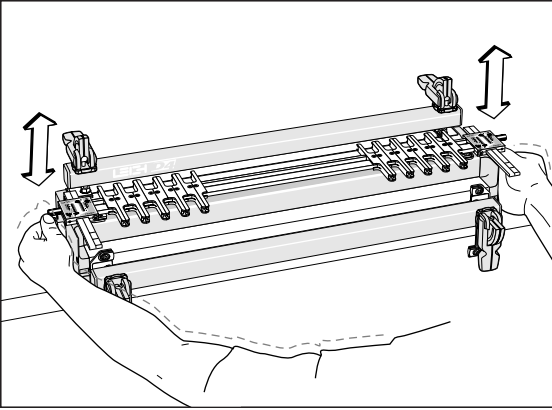
**3-1**

Practice with the finger assembly height adjustment. Loosen the support bracket knobs and hold them firmly. Raise and lower the assembly evenly, keeping it level, and tighten the knobs to lock it at various heights.

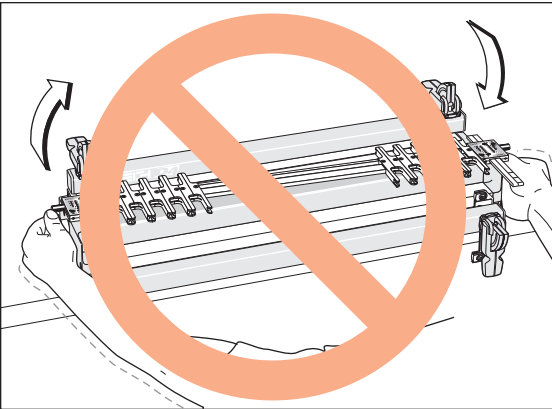
**3-2**

Do not raise or lower one end of the finger assembly at a time.

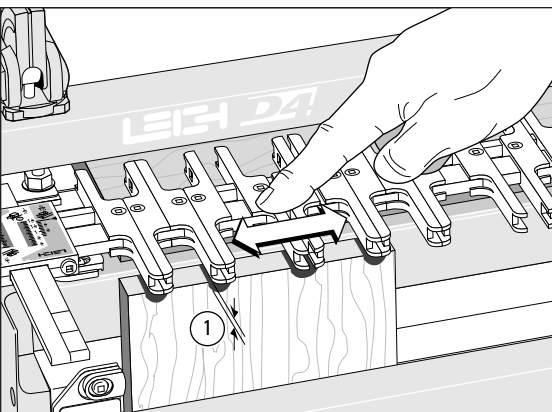
**3-3**

To practice adjusting the guidefingers, put a board in the front clamp. Always raise the finger assembly slightly above the spacer board and/or workpiece, approximately  $\frac{1}{16}$ " [2mm]-①. This allows the guidefingers to move freely on the guidefinger bar. Move the guidefingers by pushing on the middle to slide them along the guidefinger bar.

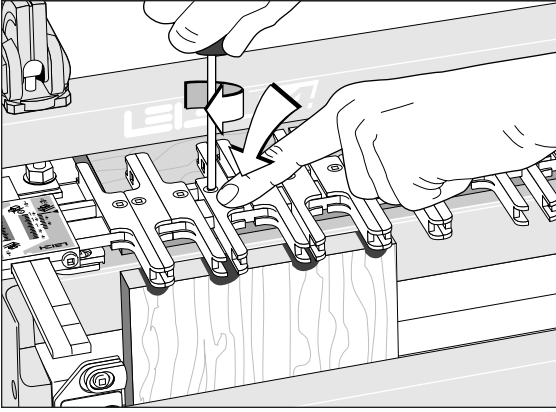
**3-4**

Loosen about half the guidefingers and practice unlocking, moving, positioning and relocking them. Always press on the centre of the guidefinger when tightening the screws.

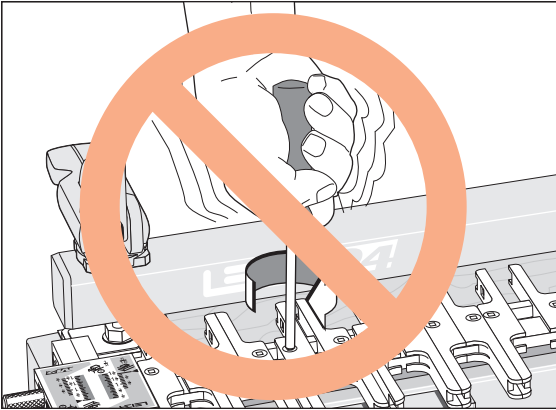
**3-5**

Do not over-tighten the guidefinger lock screws. The Leigh screwdriver provided will give ample torque for easy lock-up without strain.

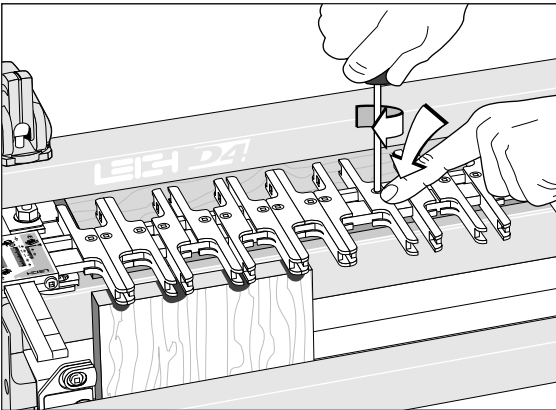
**3-6**

Always tighten unused guidefingers before routing, as router vibration may cause loose screws and wedge nuts to fall out and be lost.

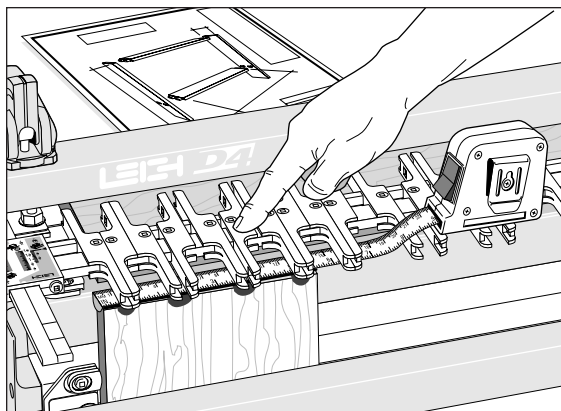
**3-7**

You can adjust the guidefingers by eye, or by measurement to suit a set of plans.



# **How Routers with Guidebuses Work**

**Chapter Foreword**

The guidebush is the vital link between router and jig. Here's how it works.

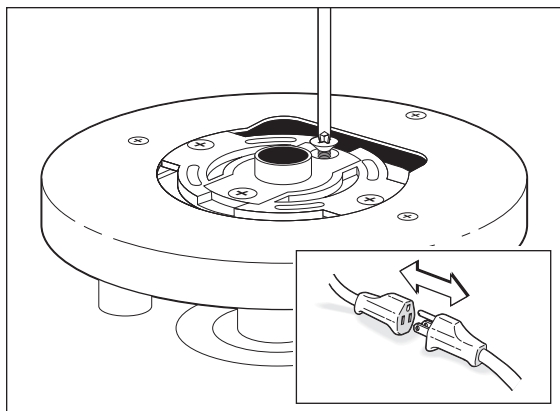
**4-1**

The guidebush attaches to the base of the router and is fixed. It does not rotate.

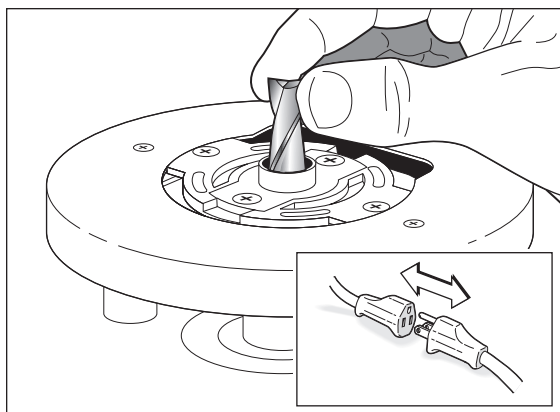
**4-2**

The cutter or bit goes through the guidebush and fits in the router collet or chuck.

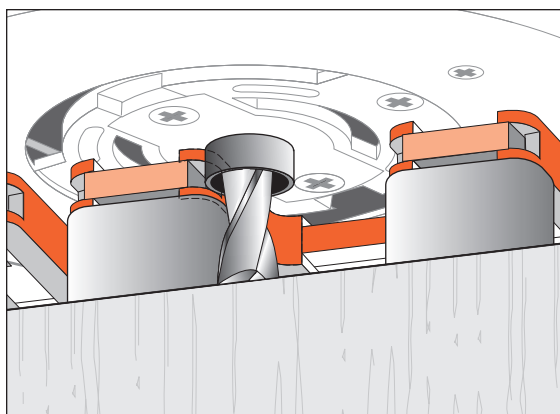
**4-3**

The projecting part of the guidebush runs along the side edge of a guide. The rotating cutter cuts the wood only, and touches neither the guidebush nor the guide surface.

*Note:  $\frac{7}{16}$ " guidebushes in the  $\frac{5}{16}$ " mode should not project more than  $\frac{1}{4}$ " [6,5mm] from the router base. File to shorten as required.*

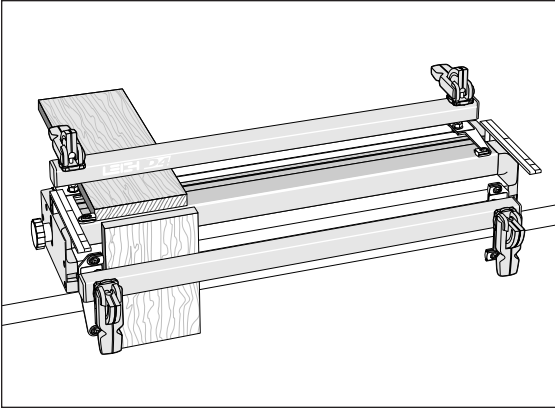

# **Basic Jig Functions**

**5-1**

The two clamp bars hold workpieces horizontally or vertically. The side stops align the boards in the same position each time.

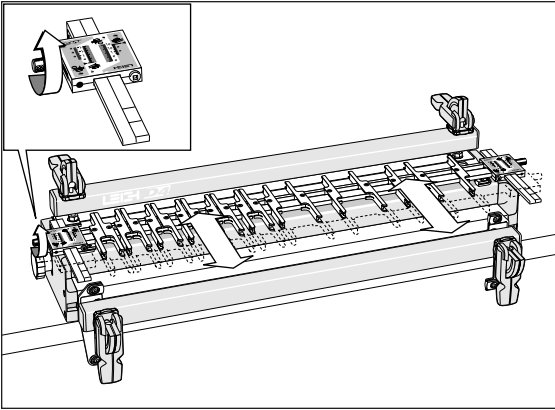
**5-2**

The guidefinger assembly slides on to the support brackets above the workpiece. The finger assembly is adjusted in or out using calibrated scales on each end to suit different mortise and tenon sizes. Note: The single rear indicator line on each support bracket is for the finger assembly. The front three lines are for the fence.

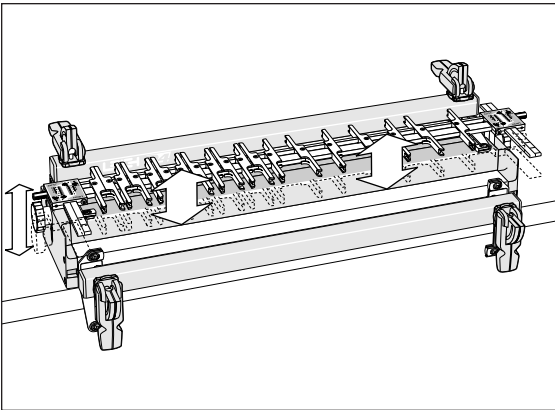
**5-3**

The finger assembly is raised or lowered using the support brackets to suit different thicknesses of horizontal boards.

### THE SCALE MODES

The Finger Assembly attaches to the support brackets in different modes to match the type of joint you are cutting. Your jig will include either inch or millimetre scales as ordered.

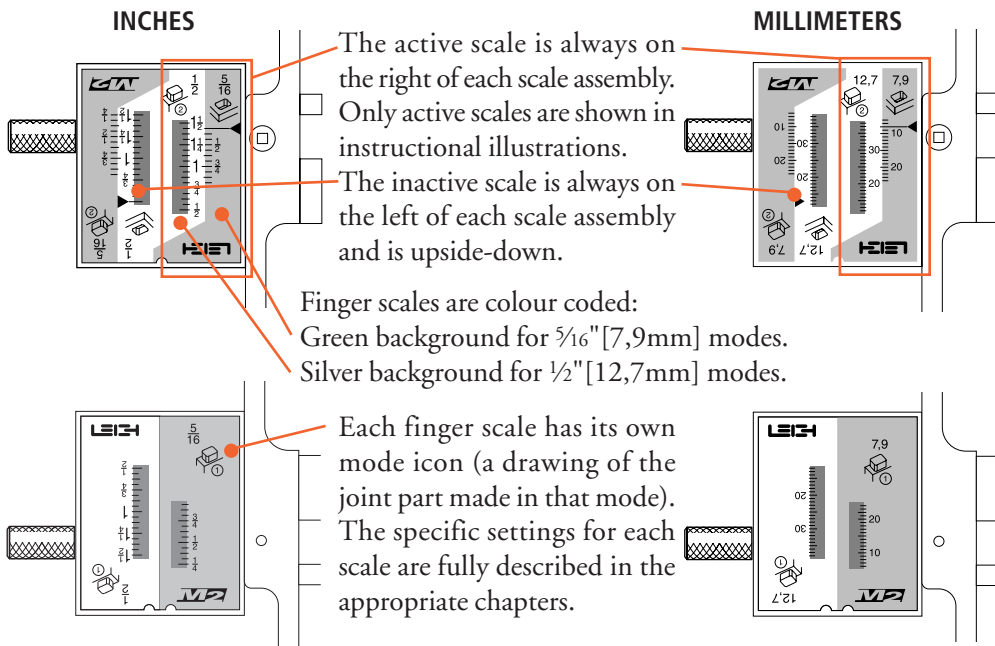

The Fence scales are solid green.  
 The ruler increments are arbitrary and used simply for fence parallel alignment.

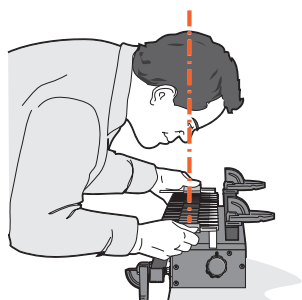
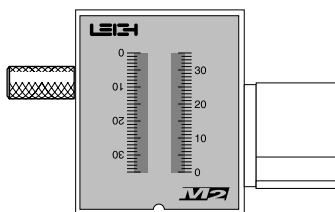

Always read scales from directly overhead to avoid parallax problems.

### THE SUPPORT BRACKETS

This line is for the finger assembly scales. The line is illustrated in red for clarity, but is black on the jig.

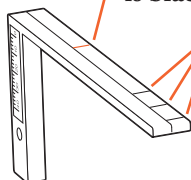

These three lines are used only for setting the fence scales. The lines only show through the active scales.

## Chapter 5 M2 User Guide

**CONCEPT OF OPERATION**

These illustrations show modes for  $\frac{5}{16}$ " [7,9mm] cutter. Start with the Finger Assembly in the  $\frac{5}{16}$ " [7,9mm]  mortise mode and without wood or router, follow these steps on your jig as a dry run. Grasping the simple basic concept of operation will greatly assist you in understanding the instructions. *Note: active guide surfaces (against which the guidebush runs) are illustrated in red.*

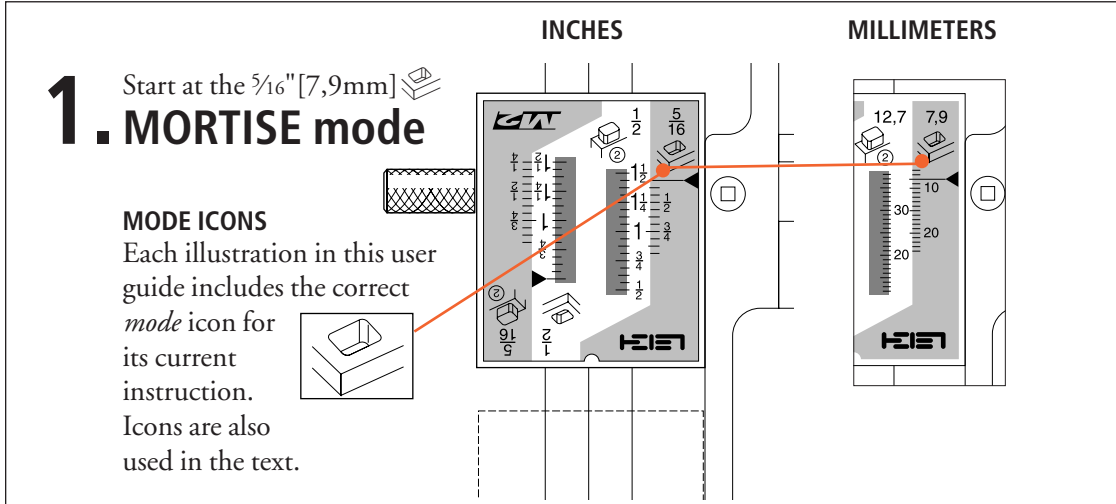
**2. ROTATE**

Remove fence and rotate the finger assembly toward you 180°

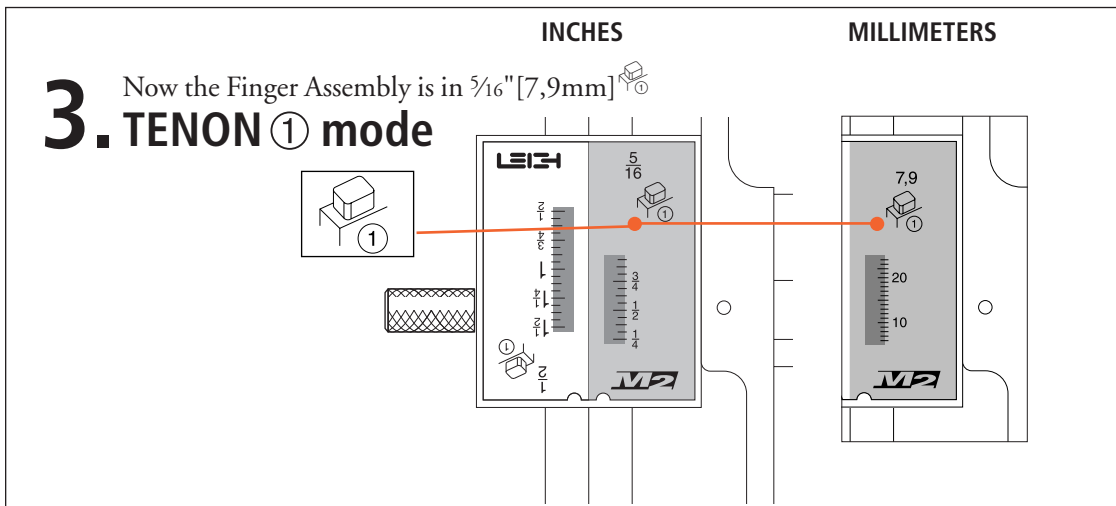
**4. FLIP**

Flip the finger assembly end-over-end 180°

### ACTIVE GUIDE SURFACES

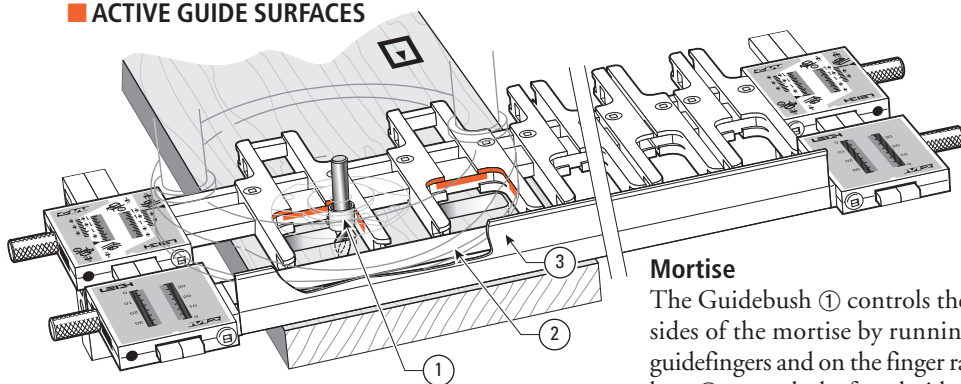

#### Mortise

The Guidebush ① controls the cut on three sides of the mortise by running on a pair of guidefingers and on the finger rail. The router base ② controls the fourth side of the mortise by running on the inside of the mortise fence ③. The mortise board is clamped horizontally under the guidefingers.

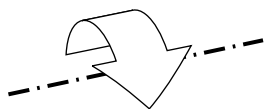

### ACTIVE GUIDE SURFACES

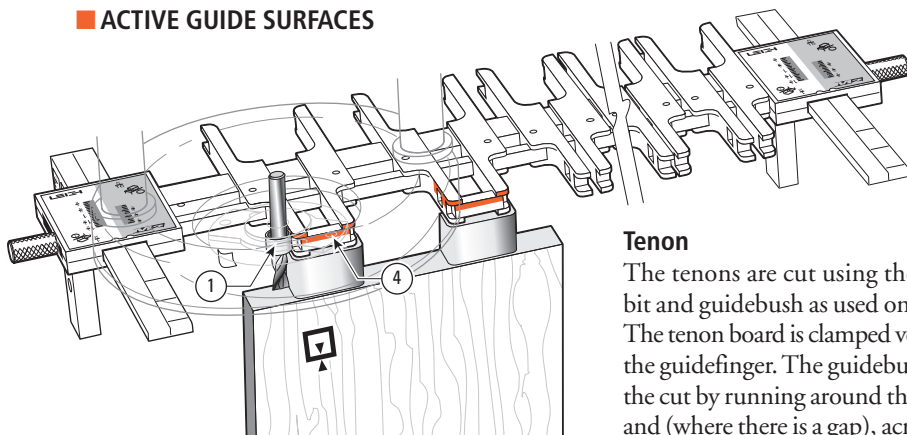

#### Tenon

The tenons are cut using the same router bit and guidebush as used on the mortises. The tenon board is clamped vertically under the guidefinger. The guidebush ① controls the cut by running around the guidefingers and (where there is a gap), across the bridge pieces ④.

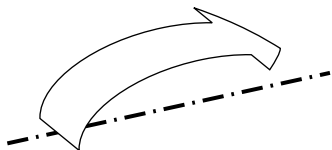

## CONCEPT OF OPERATION

# 5. Finish in $\frac{5}{16}$ " [7,9mm] mode

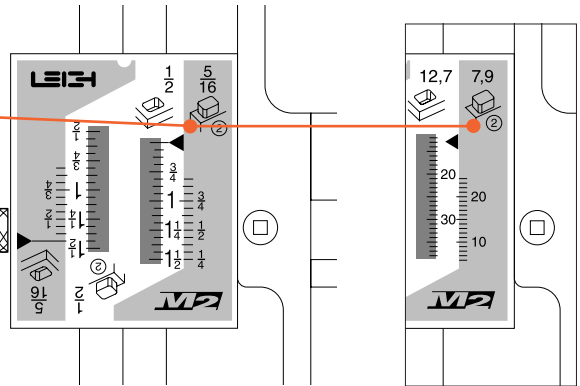
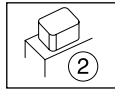

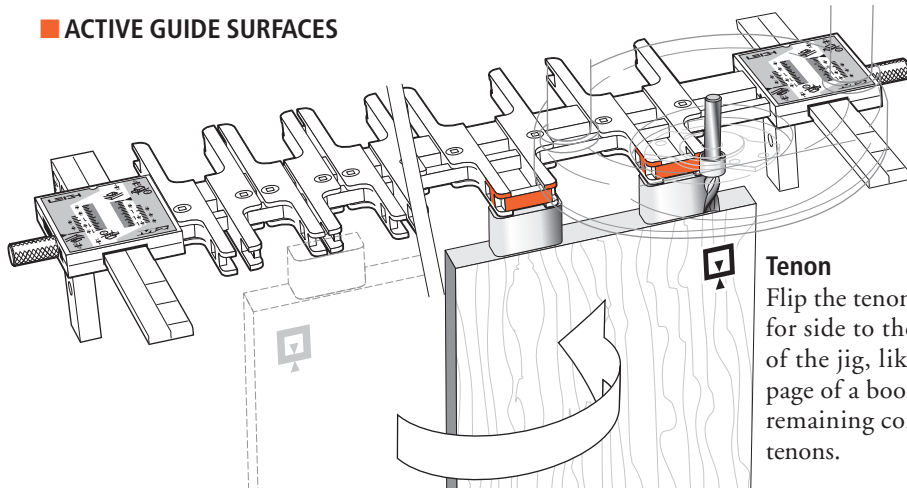
**ACTIVE GUIDE SURFACES****Tenon**

Flip the tenon board side for side to the other end of the jig, like turning a page of a book. Rout the remaining corners of the tenons.

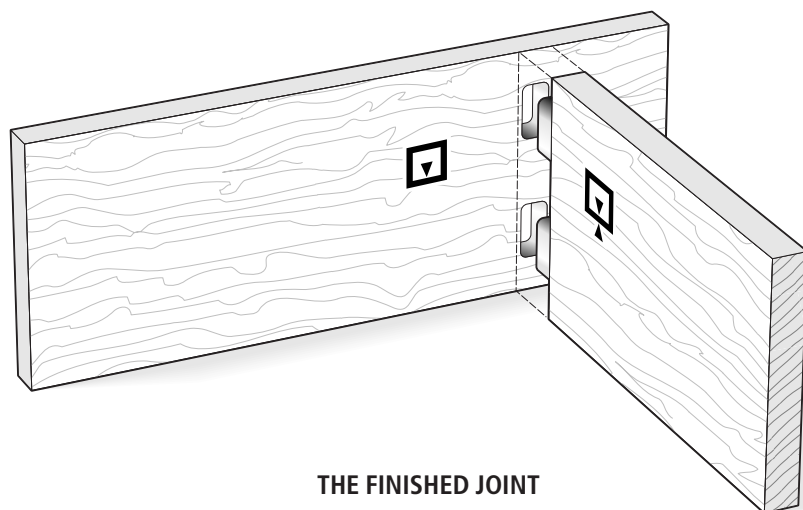
**THE FINISHED JOINT**



*M2 – CHAPTER 6*

---

# **Wood Preparation**

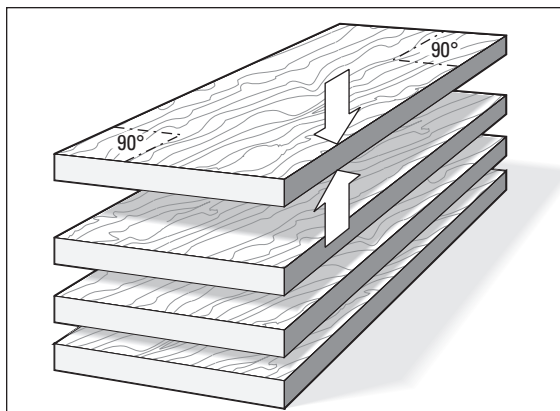

**6-1**

Stock for use on the Leigh M2 should generally be prepared straight, flat, of even thickness and equal widths, with square ends and edges. The jig will work with boards of many odd shapes, but make sure the jig can function properly with the required shape of board before you try to use it on a project workpiece.

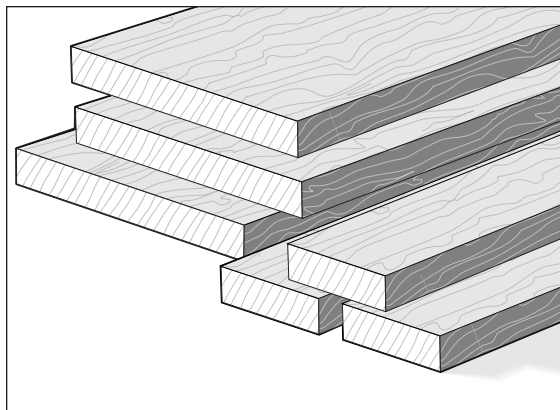
**6-2**

You will want to test the M2, so prepare some lengths of  $\frac{3}{4}$ " x  $5\frac{1}{2}$ " [20 x 140mm] boards and some narrow pieces the **exact same thickness**. Cut them to length as you need them for the various jig tests you want to perform. Use them for practice with the jig's various joint modes so you can see how the different modes work. **Remember, though, that boards of different thicknesses can be joined just as easily.**



# **The Multiple Mortise and Tenon Joint**

## Joint Description

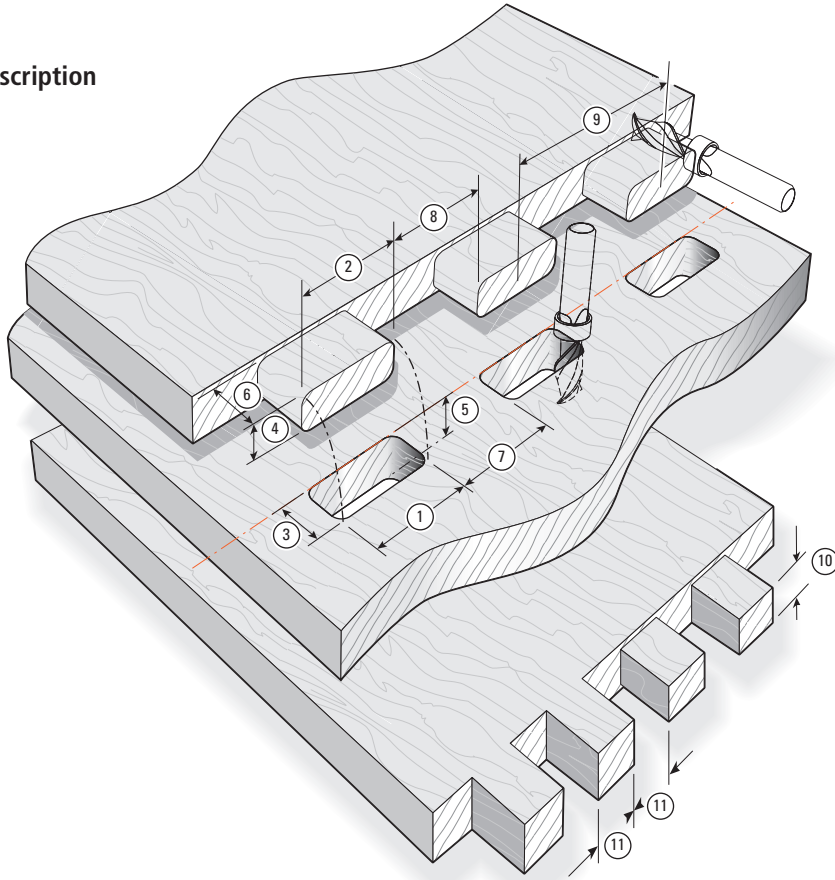

- WIDTH** ① **Mortise Width** is controlled by the distance between single guidefingers. ② **Tenon Width** is controlled by the distance between single guidefingers – the same setting as for the mortises!
- HEIGHT** ③ **Mortise Height** is controlled by the distance between the finger rail and mortise fence. ④ **Tenon Height** and ⑩ **Square Tenon Height** are controlled by the finger scale setting.
- DEPTH** ⑤ **Mortise Depth** is controlled by the depth of cut of the router cutter. ⑥ **Tenon Depth** is controlled by the depth of cut of the router cutter.
- SPACING** ⑦ **Mortise Spacing** is controlled by the distance between pairs of guidefingers. ⑧ **Tenon Spacing** and ⑪ **Finger Joint Spacing** are controlled by the distance between pairs of guidefingers – the same setting as for the mortises!

Note: Closest mortise and tenon centres ⑨: 1¼" [31,75 mm]

## Joint Technical Specifications, Guidebush and Cutter Selection

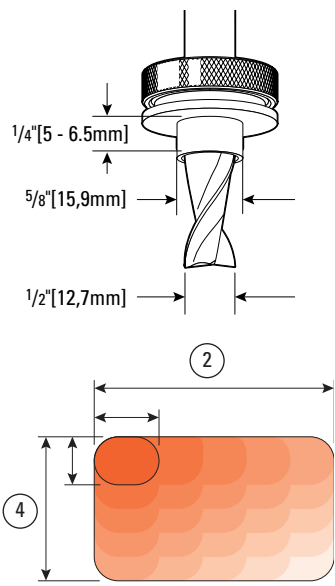
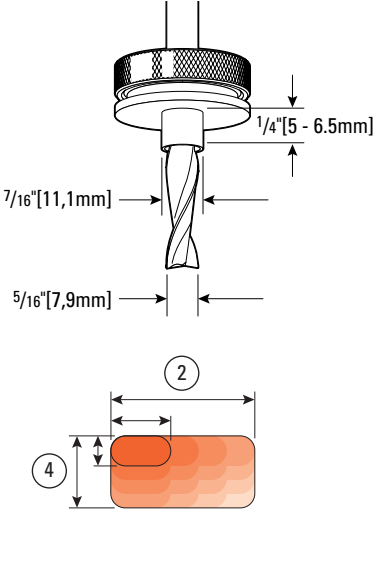
	<b>Option 1:</b>	<b>Option 2:</b>
	$\frac{5}{8}$ " [15,9mm] outside dia. Guidebush and $\frac{1}{2}$ " [12,7mm] Spiral Upcut Cutter*	$\frac{7}{16}$ " [11,1mm] outside dia Guidebush and $\frac{5}{16}$ " [7,9mm] Spiral Upcut Cutter
Width of Joint	Up to 24" [610mm]	Up to 24" [610mm]
Tenon Board Thickness	$\frac{1}{2}$ " [13mm] to $1\frac{1}{2}$ " [38mm]	$\frac{5}{16}$ " [8mm] to $\frac{3}{4}$ " [20mm]
Mortise Board Thickness	Up to $1\frac{1}{2}$ " [38mm]	Up to $\frac{3}{4}$ " [20mm]
④ Tenon Height	$\frac{1}{2}$ " [12,7mm] to $1\frac{1}{2}$ " [38mm]	$\frac{5}{16}$ " [7,9mm] to $\frac{3}{4}$ " [20mm]
② Tenon Width	$\frac{5}{8}$ " [15,9mm] to $2\frac{1}{4}$ " [60mm]	$\frac{5}{8}$ " [15,9mm] to $1\frac{1}{2}$ " [40mm]
⑩ "Square" Tenon Height	$\frac{1}{2}$ " [12,7mm] to $1\frac{3}{8}$ " [35mm]	$\frac{5}{16}$ " [7,9mm] to $\frac{3}{4}$ " [20mm]
⑪ Finger Joints	$\frac{5}{8}$ " [15,9mm] width/up, variable	$\frac{5}{8}$ " [15,9mm] width/up, variable
⑨ Closest Tenon Centres	$1\frac{1}{4}$ " [31,75mm]	$1\frac{1}{4}$ " [31,75mm]
		

### Notes

\*  $\frac{1}{2}$ " [12,7mm] spiral upcut bit HSS, standard equipment.

Guidebushes must have a minimum  $\frac{7}{32}$ " [5mm] to maximum  $\frac{1}{4}$ " [6,5mm] projection from router base.



*M2 – CHAPTER 8*

---

# **Operations Procedures for Mortises**

**IMPORTANT:** Before using this attachment on a project, thoroughly familiarize yourself with the following procedures and adjustments. Use low cost  $\frac{3}{4}$ " [20mm] solid wood and practice until proficient.

**Note:** Procedures for  $\frac{5}{16}$ " [7,9mm] cutter and  $\frac{7}{16}$ " [11,1mm] guidebush are identical, but see 8-21 regarding change of finger orientation.

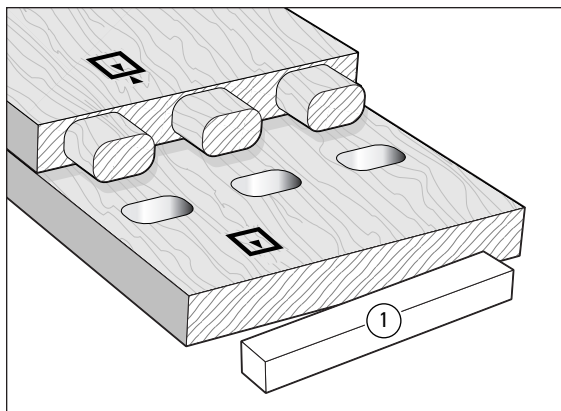

### 8-1

Let's look at how to make a simple multiple mortise & tenon joint. Make a single matching row of mortises and tenons without regard for symmetry or alignment. Example: Using  $\frac{1}{2}$ " [12,7mm] cutter and  $\frac{5}{8}$ " [15,9mm] guidebush combination and  $\frac{5}{8}$ " [15,9mm] high tenons in  $\frac{3}{4}$ " [20mm] stock.

For this procedure you will require the "mortise block"-①. See 1-7 for mortise block description.

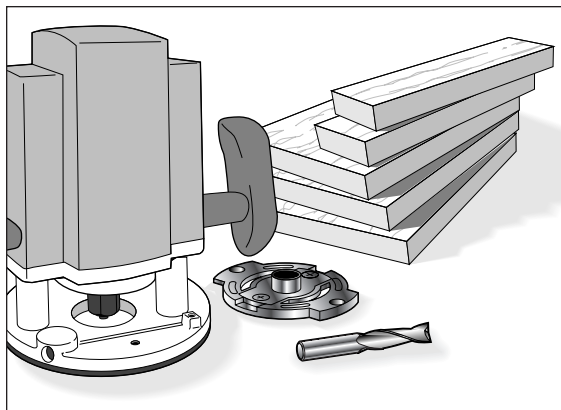

### 8-2

You will need some practise boards  $\frac{3}{4}$ "-x-5 $\frac{1}{2}$ "-x-12" [20 x 140 x 305mm] or so long, plus two narrow boards **exactly the same thickness** for single test tenons. For this trial use a plunge router with  $\frac{1}{2}$ " [12,7mm] collet,  $\frac{5}{8}$ " [15,9mm] guidebush, and  $\frac{1}{2}$ " [12,7mm] spiral upcut cutter (Leigh No.180).

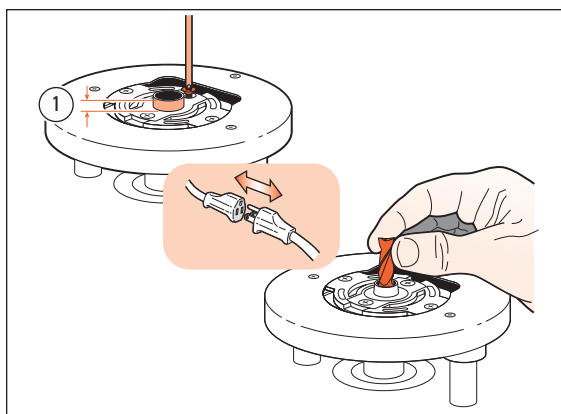

### 8-3

Fit the  $\frac{5}{8}$ " [15,9mm] guidebush securely to the router. **Guidebush projection from the router base must be at least  $\frac{7}{32}$ " [5mm] and must not exceed  $\frac{1}{4}$ " [6,5mm]**-①.

Fit the  $\frac{1}{2}$ " [12,7mm] spiral upcut cutter to the router.

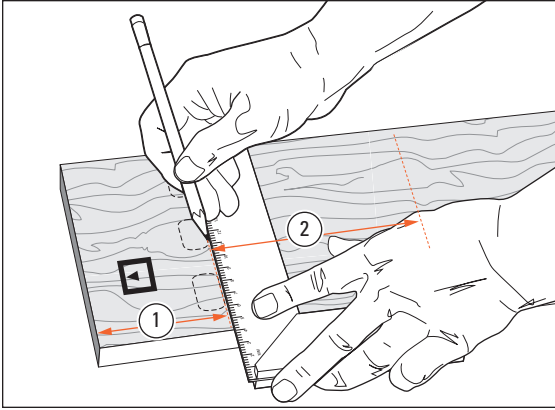

#### 8-4 Joint Layout

Mark out the position of the top edge of the mortise row which will go towards the rear of the jig (the *mortise line*), about 4" [100mm] from the board end ①. Mark this line on the inside face ❷.

It is not necessary to outline the mortises, we have just illustrated them here for clarity.

*Note: the closest that a mortise line can be to the clamping end of a board is between 5½" [140mm] to 6½" [165mm] ②.*

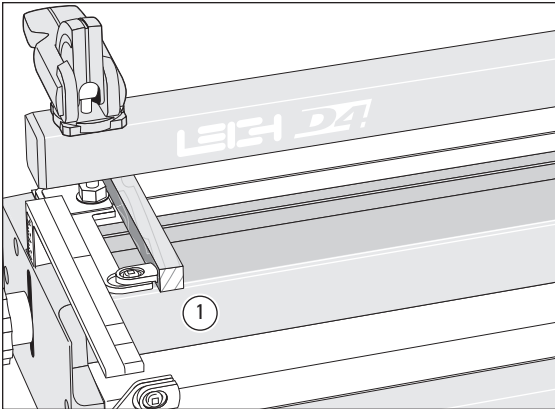

#### 8-5

Place the mortise block against the top left hand side stop ①. Keep it there for all mortising procedures.

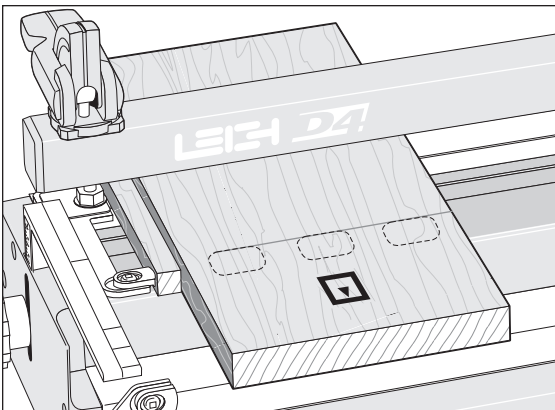

#### 8-6

Fit the mortise board horizontally under the rear clamp bar, inside face ❷ up, against the mortise block/side stop, and lightly clamp. The board position is not critical at this time.

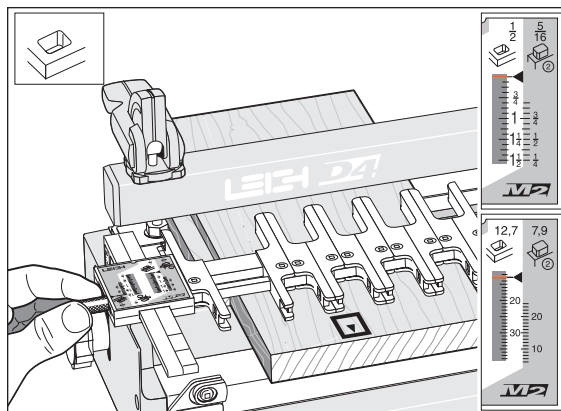
**8-7**

Place the finger assembly on the support brackets in  $\frac{1}{2}$ " [12,7mm]  mortise mode and exactly on the  $\frac{1}{2}$ " [12,7mm] setting indicated on the scale with a black triangle pointer. The position is illustrated here in red. Tighten thumb screws.

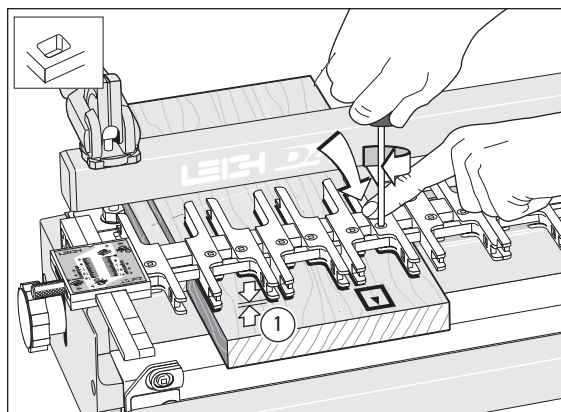
**8-8**

Lower finger assembly to within  $\frac{1}{16}$ " [2mm] of mortise board ①. Loosen and adjust fingers to the desired layout of mortises, and retighten. Do not overtighten the finger lock screws. The special screwdriver provided will give more torque than is necessary for adequate lock-up. **Always apply (hand) finger pressure to the guidefinger above the large  $\frac{3}{4}$ " [19mm] guide rail when tightening up the finger screws.**

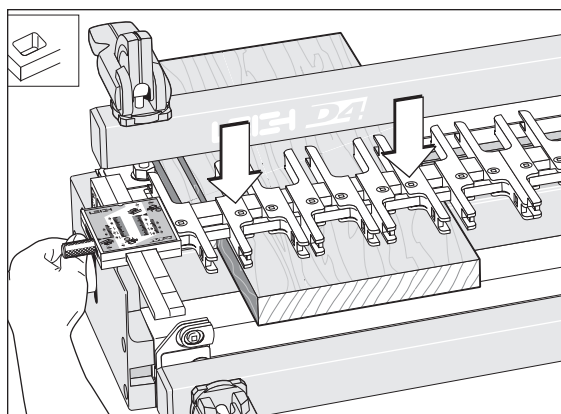
**8-9**

Lower finger assembly flush onto the mortise board and tighten end bracket knobs. *Ignore mortise line for now!*

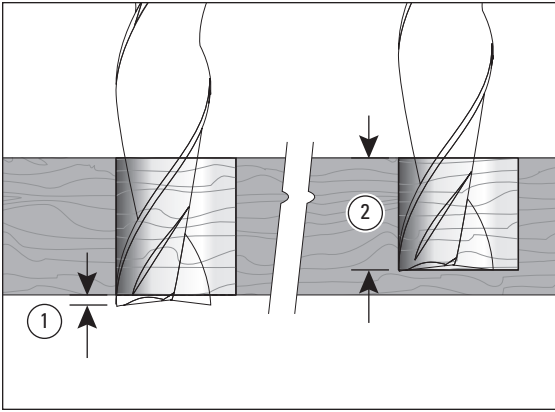
**8-10**

Always adjust and check for correct depth of cut.

Through mortises should be cut with the cutter clearly through the board ①.

Blind mortises should be cut to your desired depth ②.

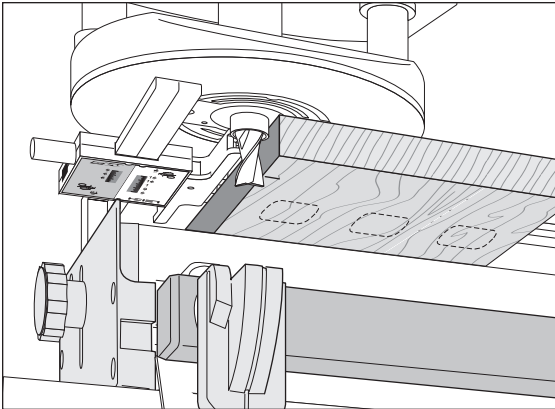
**8-11**

For these sample through mortises, adjust the plunge router depth stop to allow for a maximum cut depth of, say, 1/8" [3mm] more than the mortise board thickness.

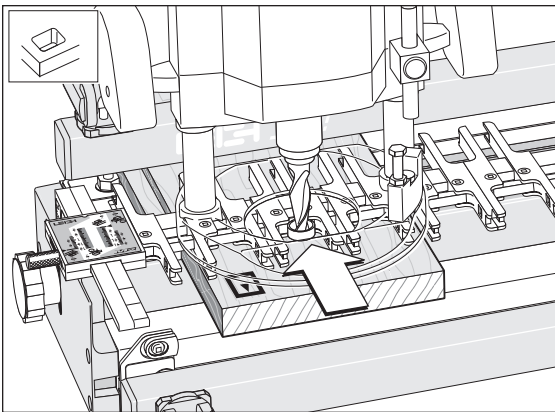
**8-12**

Position plunge router (unplugged) with plunge raised on the finger assembly, guide-bush touching the front finger rail.

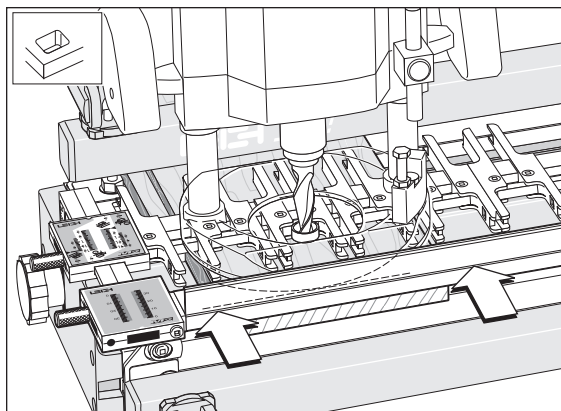
**8-13**

Place mortise fence on support brackets, fence up, until the fence touches the router base. With some small router bases, the fence may touch the fingers before reaching the router base. If so, See Figs. 8-14 and 15 below, otherwise, go directly to Figure 8-16.

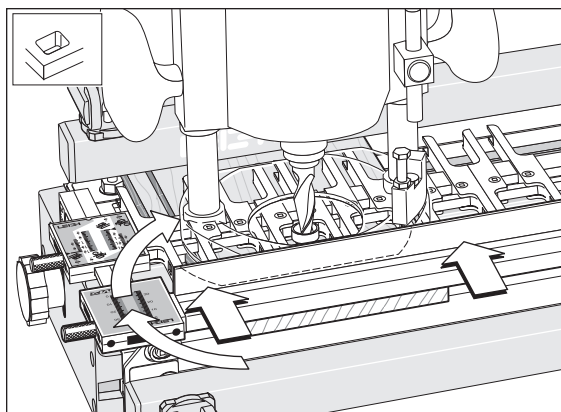
**8-14**

With some smaller router bases it may be necessary to turn the fence end for end, replace on brackets and use back of fence as a guide.

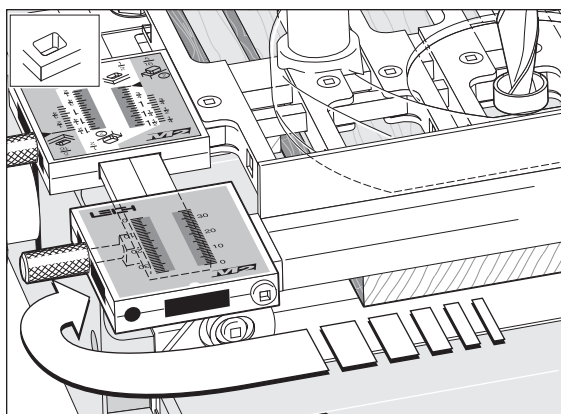
**8-15**

In some cases it may even be necessary to reverse the scales end for end on the fence to ensure the scale thumb screws are far enough in to engage the support brackets.

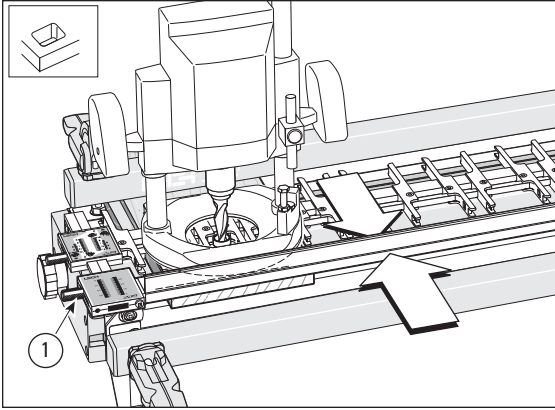
**8-16**

With **light inward pressure** on the fence, equalize the fence scale reading at each end of the jig on the most convenient pair of support bracket lines and tighten the fence scale thumb screws ①. This will parallel the fence with the finger assembly. **Check for free left-right router movement at both sides of the mortise board.**

Remove router from jig.

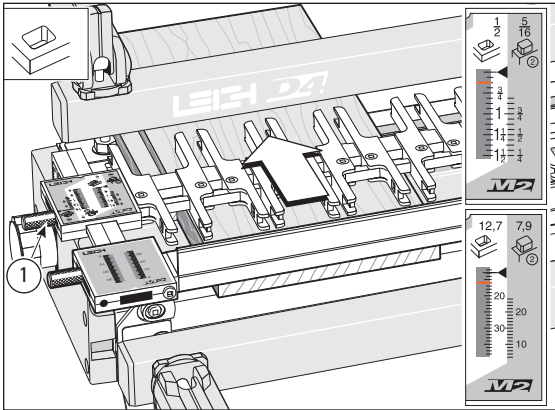
**8-17**

At the  $\frac{1}{2}$ " [12,7mm] setting, and the router trapped between the finger rail and fence, the router can only cut  $\frac{1}{2}$ " [12,7mm] high mortises, i.e. the cutter diameter. Move the finger assembly toward the rear of the jig so the scales read the required mortise height,  $\frac{5}{8}$ " [16mm] in this instance. Tighten the thumb screws ①.

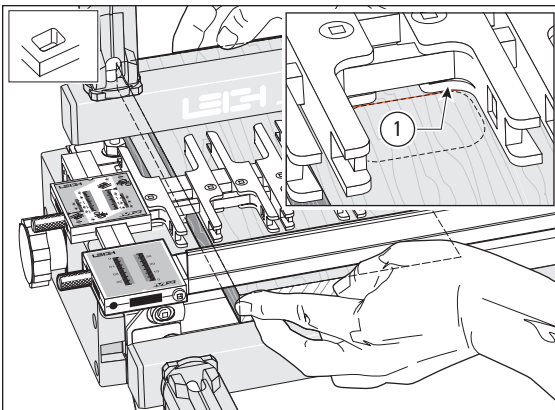

**8-18**

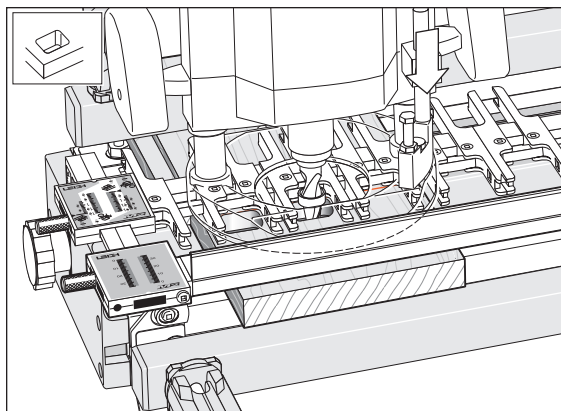
Loosen the rear clamp and align the first *mortise line* just in front of the small projections on each guide finger ①, i.e. full line thickness showing in front of projection, and the edge of the board against the mortise block/side stop. Firmly clamp in place.

**8-19**

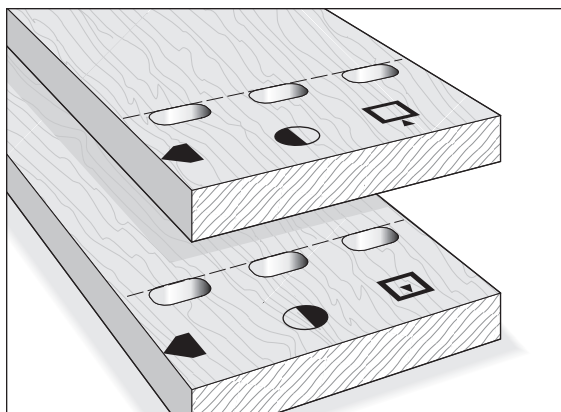
Rout out all mortise positions on this row and on all similar rows. Plunge and rout about one third of the board thickness at a time.

**8-20**

If you are routing through mortises in opposite cabinet sides, use the same reference edge (cabinet front or rear) against the same side stop each time. One side of the cabinet would be routed outside face  up; the other side, inside face  up.

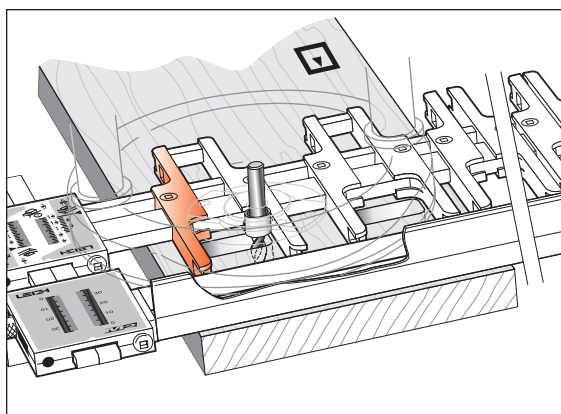
**8-21**

When routing with a  $\frac{5}{16}$ " [7,9mm] cutter, the outer finger (highlighted in red) is used as a guidefinger.



# **Operations Procedures For Tenons**

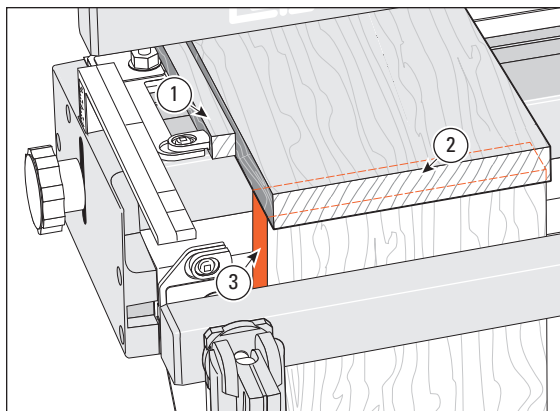

**9-1**

Remove the mortise fence and the finger assembly. Clamp a straight sided board in the rear clamp, touching against the mortise block/side stop ①, and the front edge overhanging the jig front ②.

Place another straight sided board in the front clamp and position it so that the top left corner is perfectly flush with the side edge of the horizontal board ③ and clamp it in place. Double check that the side edges are flush at ③ and leave both boards in place.

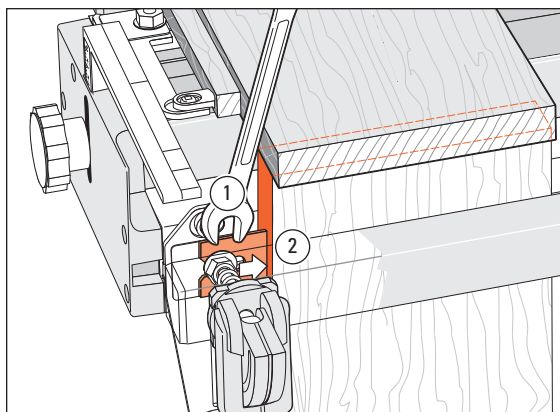
**9-2**

Slightly loosen the left hand clamp bolt nut ① (this will not loosen the board) and slide the side stop extension to touch flush and square to the edge of the vertical board ②. Hold it in position and tighten the nut. Remove both boards.

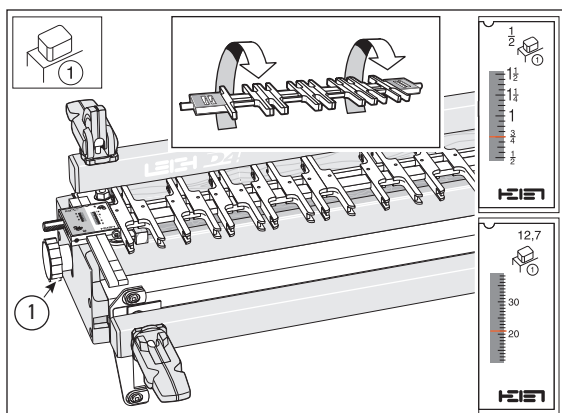
**9-3**

Rotate the finger assembly toward you 180° and replace it on the support brackets in the 1/2" [12,7mm]  tenon mode. The scale setting is not important for now. Fit the jig spacer board in the rear clamp, under the finger assembly. Lower the fingers flush onto the board and tighten the support bracket knobs ①.

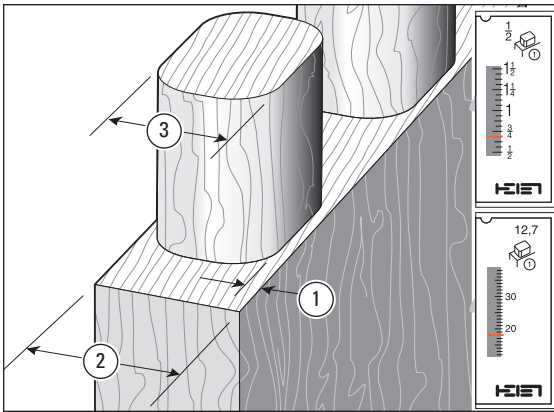
**9-4**

For a crisp appearance, shoulder the tenons slightly ①. For corrected scale reading, use this formula:

$$\text{Tenon Board Thickness } \textcircled{2} \\ + \text{Mortise Height } \textcircled{3} \\ \div 2 = \text{Tenon Scale Setting}$$

Example:  $(\frac{3}{4}"[20\text{mm}] + \frac{5}{8}"[16\text{mm}]) \div 2 = \frac{11}{16}"[18\text{mm}]$

Set  $\frac{1}{2}"[12,7\text{mm}]$  ① tenon scale on  $\frac{11}{16}"[18\text{mm}]$  or on your actual calculated setting.

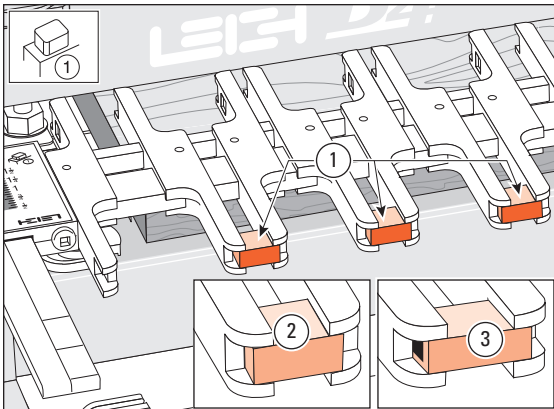
**9-5**

Fit tenon bridge pieces ① where there are gaps between the tenon guides (just like half-blind dovetail tails). To make bridge pieces, use a strip of  $\frac{1}{4}"[6,35\text{mm}]$  by  $\frac{1}{2}"[12,7\text{mm}]$  hardwood such as maple. Fit short pieces in the slots on the inside finger faces ②. Ensure a tight sliding fit on the  $\frac{1}{4}"[6,35\text{mm}]$  dimension only.

D4R and D4R Pro owners may use the plastic bridge material ③ supplied with that jig.

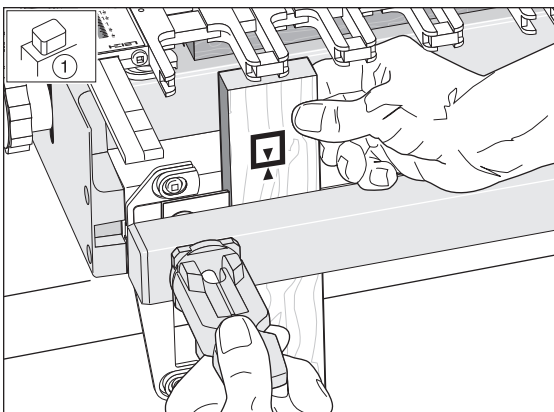
**9-6**

Fit a narrow test piece, **exactly the same thickness as the workpiece**, vertically in the front clamp under a pair of tenon guides. It does not have to be touching the side stop extension for this “fit test”.

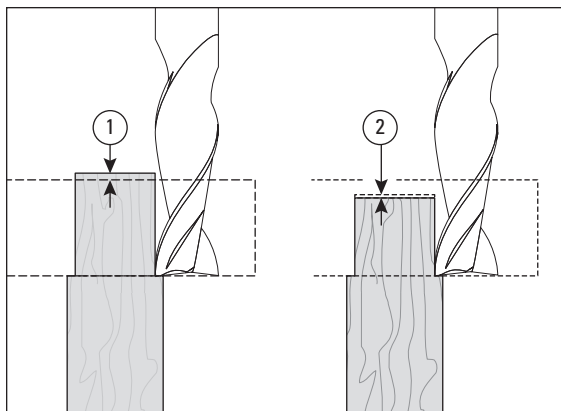
**9-7**

Always adjust and check for correct depth of cut.

Through tenons should be cut to project slightly through the mortises to allow for cleanup ①.

Tenon depth for blind mortises should be cut slightly less than than the mortises to ensure clearance during assembly ②.

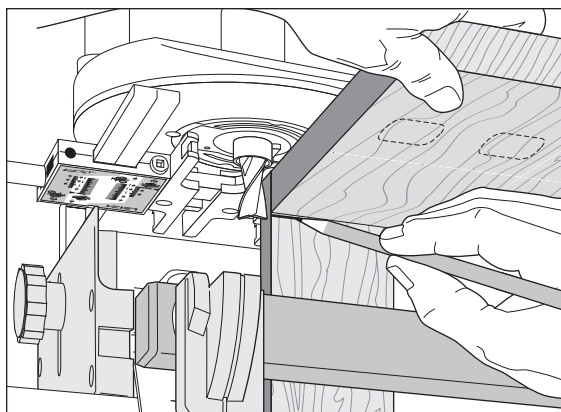
**9-8**

For through tenons, use the mortise board to mark its thickness onto the test board. Lower the cutter depth to suit.

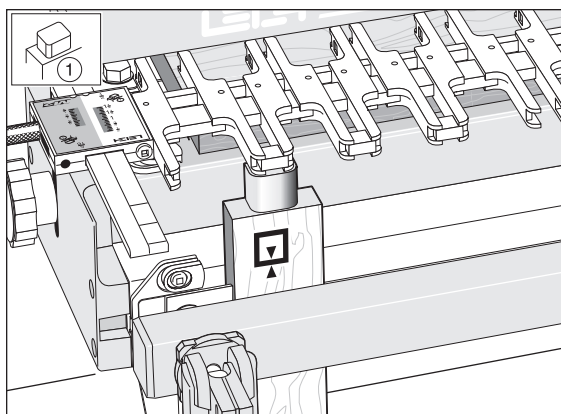
**9-9**

Rout around the tenon guides and bridge piece to cut the first part of the tenon.

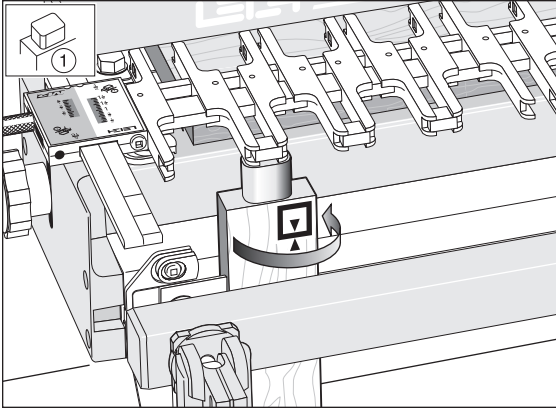
**9-10**

Remove the test piece and turn it 180° under the same tenon guide and re-clip. **Side to side alignment is not critical, you are only testing tenon height.** Rout the other half of the test tenon.

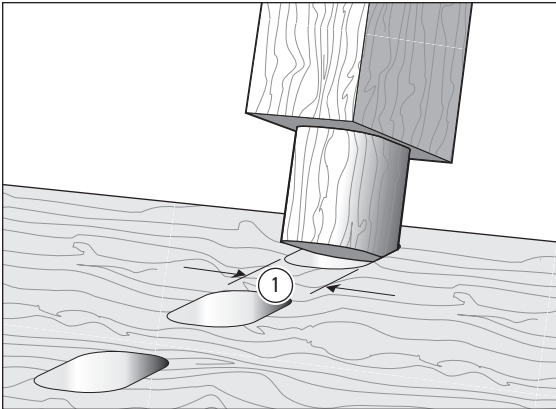
**9-11**

Try the test tenon in a mortise to test tenon height ①. If tenon height is *loose*, move the finger assembly out (towards the operator) by half the difference, e.g., if the tenon height is  $\frac{1}{32}$ " [1mm] loose, move the finger assembly out by  $\frac{1}{64}$ " [0,5mm]. If *too tight*, move the finger assembly in (away from operator) by half the difference. Cut other test tenons as required to achieve the desired fit. Record the  $\frac{1}{2}$ " [12,7mm]  tenon scale setting and leave it in position.

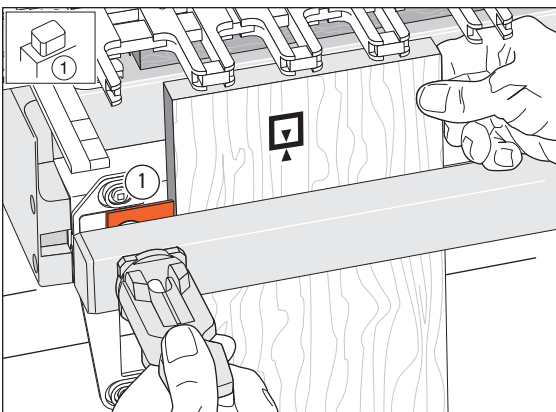
**9-12**

Fit the tenon workpiece in the front clamp at the left hand end, it can be either face in or out . It should lightly touch the underside of the guide fingers and the left hand side stop extension ①.

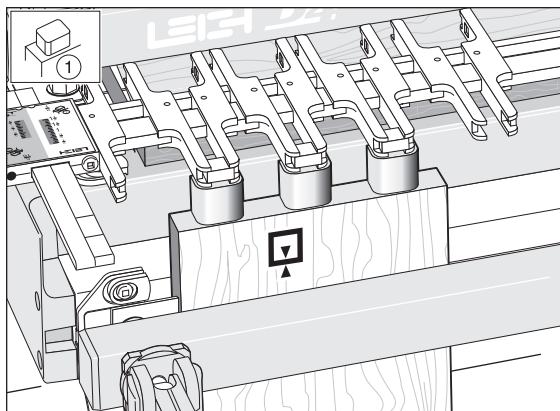

**9-13**

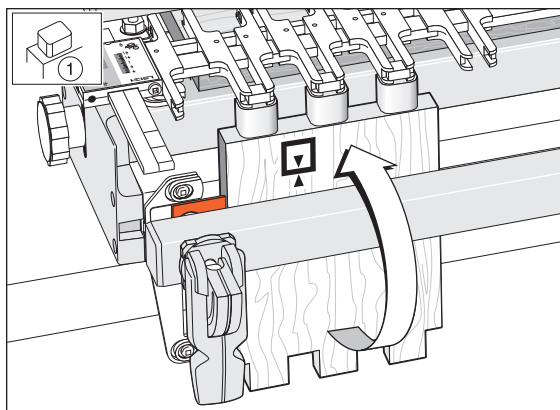
Rout the first half of the tenons.

**9-14**

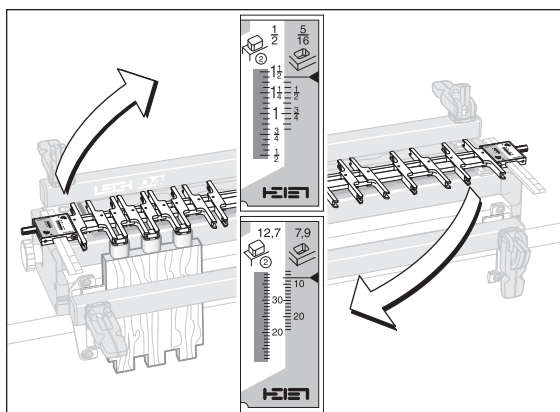
Flip the board end for end, keeping the same board edge to the side stop extension. Rout the first half of tenons at the opposite end of the board under the same guide fingers. Repeat with all similar tenon boards. **IMPORTANT:** Rout an extra scrap tenon board of the same thickness but not necessarily the same length or width.

**9-15**

Make sure you noted the scale setting. Remove the finger assembly and flip it end for end to the  $\frac{1}{2}$ " [12,7mm]  tenon mode. Set it on exactly the same recorded position as for the  $\frac{1}{2}$ " [12,7mm]  tenon mode.

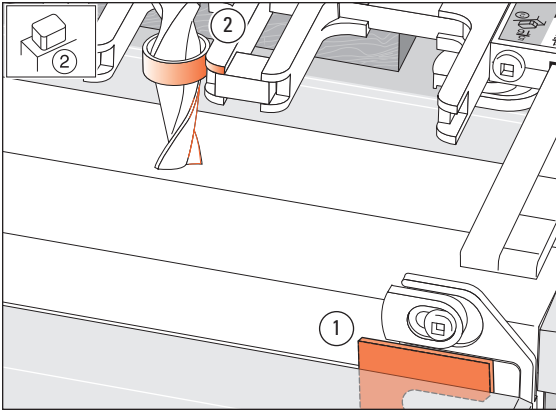
**9-16**

You now need to set the right hand side stop extension-①. First, place the router (unplugged) onto the finger assembly, with the cutter plunged and the guidebush contacting the side of a guidefinger-②.

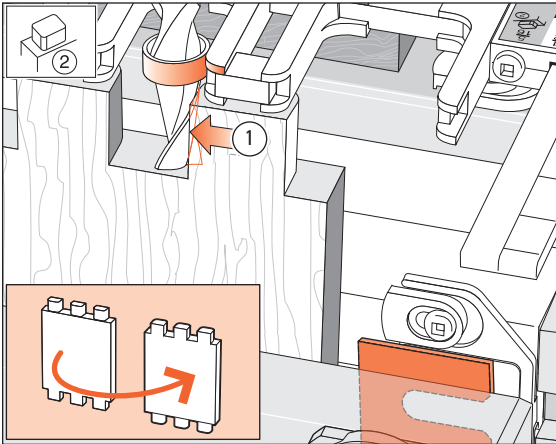
**9-17**

Remove the scrap tenon board. Turn it to the right hand end of the jig, like turning the page of a book, and position it under the guides with a tenon lightly touching the cutter-①. Making sure that the guidebush maintains contact with the finger and the tenon with the cutter; clamp the workpiece.

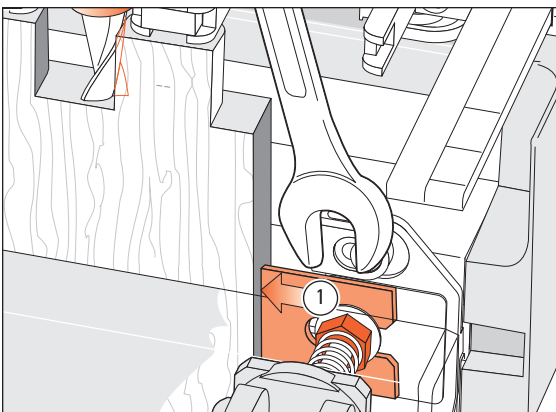
**9-18**

Now loosen the right hand clamp bolt nut and slide the side stop extension out to touch flush and square to the edge of the tenon board-①. Hold it in position and tighten the nut.

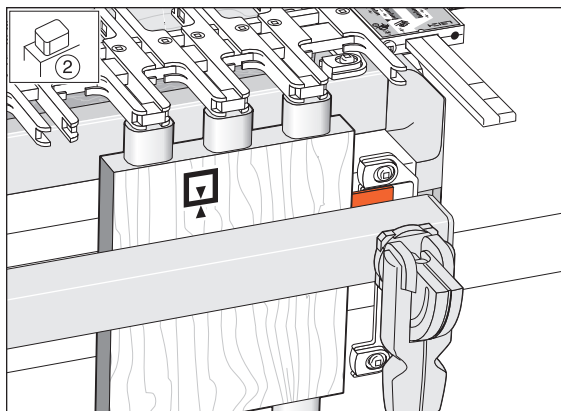
**9-19**

Route one end of the scrap tenon board and test for accuracy. Repeat the sidestop extension adjustment if necessary. Finish routing the scrap tenons and test for fit. If necessary, make final adjustments for tenon height before routing the second half of all tenons.

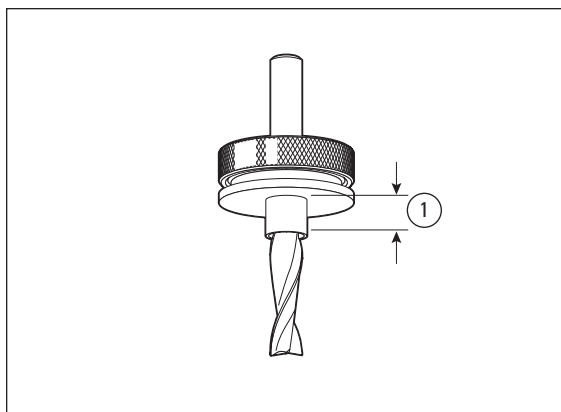

**9-20**

Procedures are identical for  $\frac{5}{16}$ " [7,9mm] cutter and scales in the  $\frac{5}{16}$ " [7,9mm] modes.

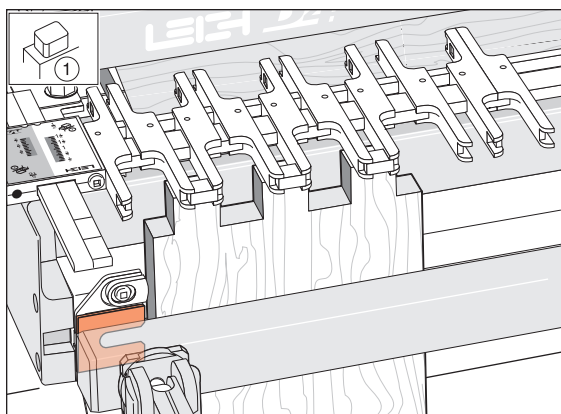
Make sure to check the length of the  $\frac{7}{16}$ " OD guidebush-①. This should not exceed  $\frac{1}{4}$ " [6,5mm].

**9-21 Square Cornered Tenons**

*Note: Because square tenons are all routed at one end of the jig, sidestop extensions are not required.*

If square tenons are required, always use the  $\frac{1}{2}$ " [12,7mm]  tenon mode. Simply move the finger assembly out to the highest  tenon setting to ensure straight-sided tenons. The mortise height will either have to be the same as the tenon board thickness, or...

Chapter 9 M2 User Guide

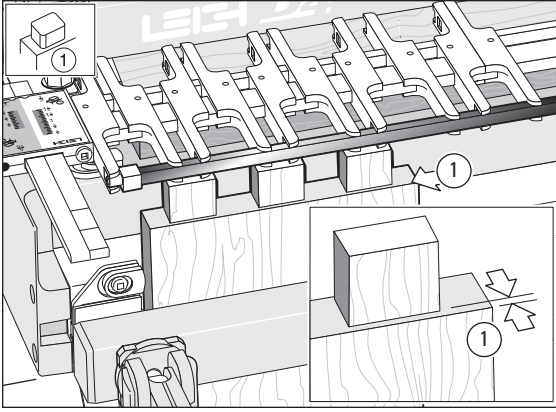

**9-22**

...remove the bridge pieces and use the dovetail jig cross cut bar to shoulder the square tenons-①.

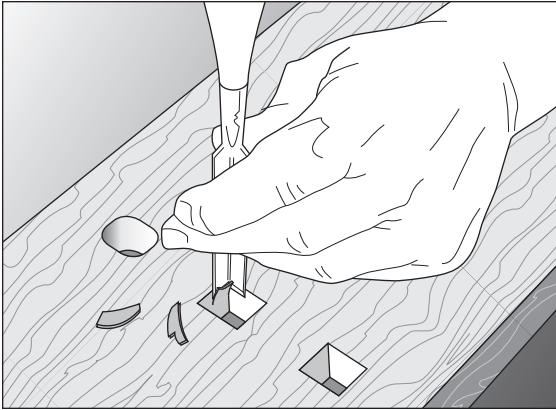

**9-23**

Mortises for square tenons will have to be chopped square in the corners – a simple matter with a good corner chisel.

*M2 – CHAPTER 10*

---



# **Beyond the Basics with the Leigh M2**

**Chapter Foreword**

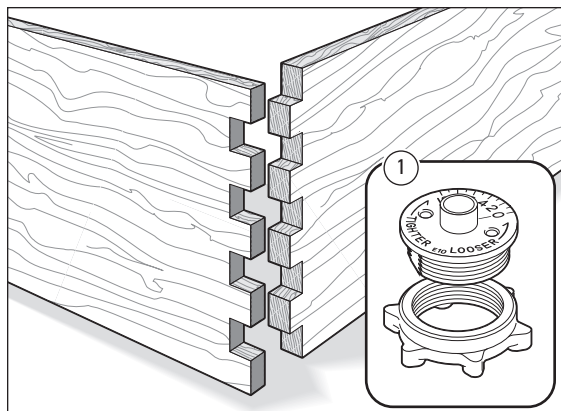
Here are some unique (and inexpensive) “joinery extras” your M2 will help you rout. No other jig in the world can produce these variably spaced box joints.



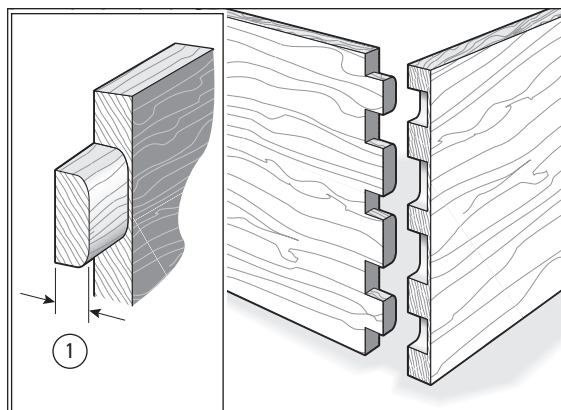

### 10-1 Finger Joints

Both cutter/guidebush size combinations produce  $\frac{5}{8}$ " [15,9mm] or larger finger/box joints, in even or uneven spacing. Cut square tenons vertically under both  mortise and  tenon guides. Make corner joints, end-on-end joints, hinges etc. Leigh adjustable guide fingers allow any workpiece joint edge finish you want. *Hint: The optional Leigh e10 oval guidebush ① provides unique adjustment for tightness of fit on box joints (not suitable for tenons).*



### 10-2 Half-Blind Variable Finger Joints

Cut the *sockets* horizontally in the  mortise mode and the *fingers* vertically in the  tenon mode with the same depth of cut, rounding only the first half of the tenons. There are no specific scale settings for horizontal socket depth/pin thickness ①, but a little trial and error testing will soon get you there.



# **Guidebush and Cutter Selection**

## Appendix I M2 User Guide

## Joint Technical Specifications, Guidebush and Cutter Selection

	Option 1:	Option 2:
	$\frac{5}{8}$ " [15,9mm] outside dia. Guidebush & $\frac{1}{2}$ " [12,7mm] Spiral Upcut Cutter*	$\frac{7}{16}$ " [11,1mm] outside dia Guidebush & $\frac{5}{16}$ " [7,9mm] Spiral Upcut Cutter
Width of Joint	Up to 24" [610mm]	Up to 24" [610mm]
Tenon Board Thickness	$\frac{1}{2}$ " [13mm] to $1\frac{1}{2}$ " [38mm]	$\frac{5}{16}$ " [8mm] to $\frac{3}{4}$ " [20mm]
Mortise Board Thickness	Up to $1\frac{1}{2}$ " [38mm]	Up to $\frac{3}{4}$ " [20mm]
④ Tenon Height	$\frac{1}{2}$ " [12,7mm] to $1\frac{1}{2}$ " [38mm]	$\frac{5}{16}$ " [7,9mm] to $\frac{3}{4}$ " [20mm]
② Tenon Width	$\frac{5}{8}$ " [15,9mm] to $2\frac{1}{4}$ " [60mm]	$\frac{5}{8}$ " [15,9mm] to $1\frac{1}{2}$ " [40mm]
⑩ "Square" Tenon Height	$\frac{1}{2}$ " [12,7mm] to $1\frac{3}{8}$ " [35mm]	$\frac{5}{16}$ " [7,9mm] to $\frac{3}{4}$ " [20mm]
⑪ Finger Joints	$\frac{5}{8}$ " [15,9mm] width/up, variable	$\frac{5}{8}$ " [15,9mm] width/up, variable
⑨ Closest Tenon Centres	$1\frac{1}{4}$ " [31,75mm]	$1\frac{1}{4}$ " [31,75mm]

## Notes

\*  $\frac{1}{2}$ " [12,7mm] spiral upcut bit HSS, standard equipment.

Guidebushes must have a minimum  $\frac{7}{32}$ " [5mm] to maximum  $\frac{1}{4}$ " [6,5mm] projection from router base.

## Leigh Template Guidebush and Adaptor System

The correct guidebush is the vital link between the router and your Leigh Jig. It precisely steers the router. Where possible, always use the Leigh system to **ensure correct bush length and precise diameter for accurate results.**

Leigh offers the adaptors shown below to fit guidebushes to over one hundred router models, new and old, including Porter Cable, Black & Decker, and DeWalt. Many other makes like Bosch, Fein, Festool, Milwaukee etc., either offer or come complete with base adaptors. For a complete list of routers and which adaptors fit them, see following pages.

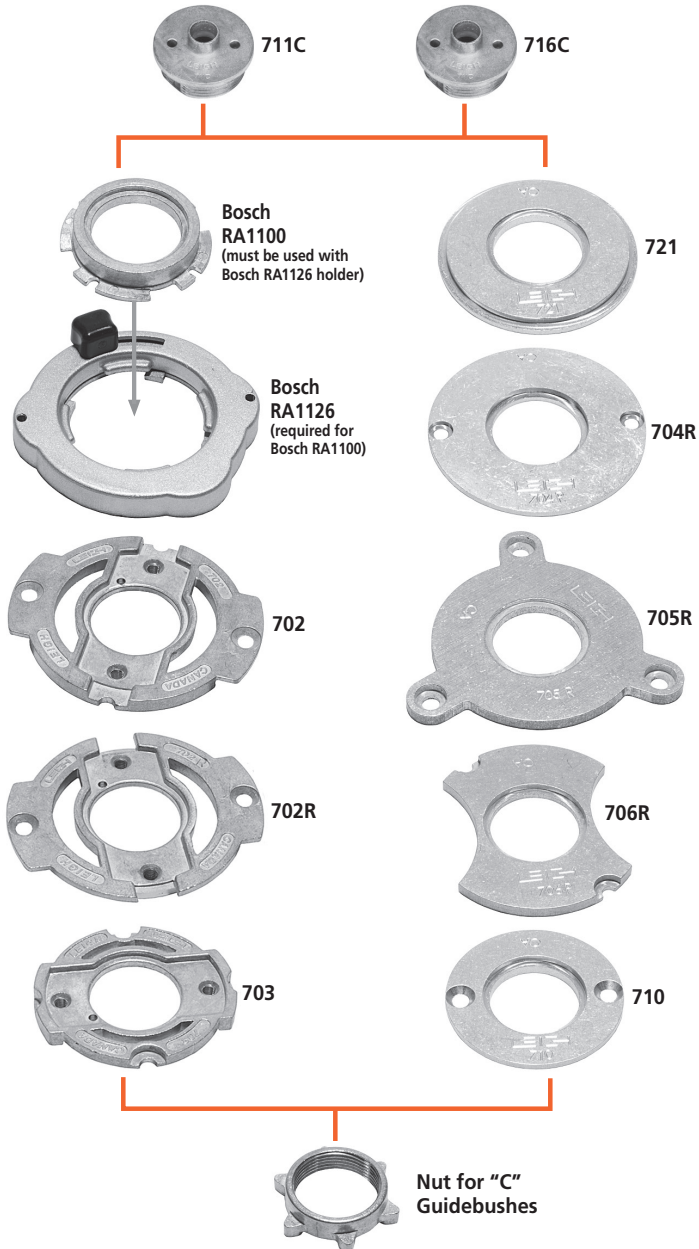

## "C" Guidebush Mounting Variations

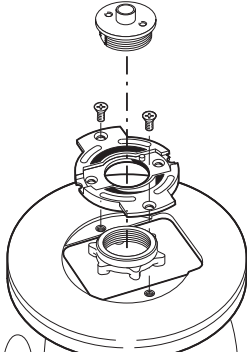

"C" Guidebush with  
Adaptors 702 & 702R

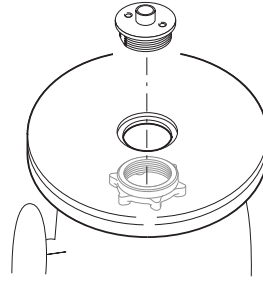

"C" Guidebushes fit  
many routers directly

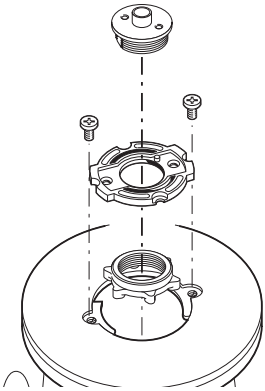

"C" Guidebush with  
Adaptor 703

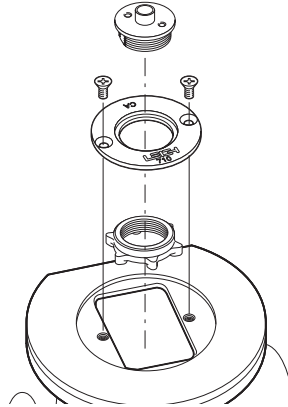

"C" Guidebush with  
Adaptor 710

# Template Guide Bushing and Adaptor Selection

Your router may need an adaptor to mount the guide bushing. Find out with this chart.

See [www.leighjigs.com](http://www.leighjigs.com) for the latest list of routers.

## DIRECTIONS

- A.** Locate name of router maker in Column 1.
- B.** Locate router model in Column 2. If your router is not listed visit [leighjigs.com](http://leighjigs.com) for a complete, up-to-date list of routers.
- C.** Locate adaptor required for your router in Column 3.
  - Order Leigh adaptors (part no's in red) in Column 3 from Leigh.
  - Order Bosch adaptors RA1100 and RA1126 in Column 3 from Leigh or your Bosch dealer.
  - Order all other adaptors in Column 3 from the router manufacturer's dealer.

**Note:** Adaptor mounting screws are included with router.

■ MAFELL – Rework adaptor slightly.

- D.** Guide bushings in Columns 4 and 5 fit all adaptors listed and may be ordered if required. Note:
  - ◆ The 7/16" [11,1mm] 711C\* guide bushing is supplied with all earlier model Leigh D-series dovetail jigs, but not with the D4R Pro – order if required.

▲ An optional 5/8" [15,9mm] 716C\* guide bushing can be used with 1/2" [12,7mm] shank router bits on the D4R Pro, D4R, D4, D3, D1258R and D1258 jigs. Order only if using 1/2" [12,7mm] shanks.

**Note:**

\*The 711C has replaced the 711TP guide bushing. Both are 7/16" OD [11,1mm].

\*The 716C has replaced the 716TP guide bushing. Both are 5/8" OD [15,9mm].

1 ROUTER MAKER	2 ROUTER MODEL	3 ROUTER ADAPTOR	4 7/16" OD BUSHING ◆	5 5/8" OD BUSHING ▲	
AEG	OFE 710 in plunge base	Not Required	711C	716C	
	OFSE 2000	703	711C	716C	
	RT1350E	706R	711C	716C	
BLACK & DECKER	All Professional, HD1250, RP400K, 7614	Not Required	711C	716C	
	6200	720673-00	711C	716C	
	SR100, 7AEE, KW780 series, KW800, KW850	710	711C	716C	
BOSCH	1600, 90085, 90088, 90098, 90140, 90150, 90300, 90303, 90305, 91264	Aftermarket base plate required	711C	716C	
	1601, 1602, 1603, 1604, 1606, B1350	RA1110	711C	716C	
	North American ROUTERS PRODUCED AFTER mid-2010: 1613EVS, 1613AEVS, 1617, 1617EVS, 1618, 1618EVS, 1619EVS, MR23EVS, MRC23EVS, MRF23EVS, MRP23EVS	RA1126 quick change adaptor and RA1100 bushing adaptor req'd		711C	716C
	North American ROUTERS PRODUCED BEFORE mid-2010 and others available worldwide that include the RA1126 adaptor: 1613EVS(AEVS), 1614(EVS), 1617EVS, 1618EVS, 1619EVS, B1450, GOF900(CE)(ACE), GOF1200, GOF1250(CE)(LCE), GOF1300(CE)(ACE), GOF1600CE, GOF2000(CE), GMF1400, GMF1600(CE), POF800(ACE), POF1100(ACE), POF1200(ACE), POF1400(ACE)	RA1100		711C	716C
	1611, 1611EVS, 1615, 1615EVS, B1550, GOF1600, GOF1700(ACE)	702		711C	716C
CRAFTSMAN (SEARS)	All non-plunge models	Aftermarket base plate required	711C	716C	
	135275070 Plunge	See Skill 1823 or 1835			
	Other plunge models	702	711C	716C	
DEWALT	MD11 Plunge & Fixed Base, MD9.5 Fixed Base	Not Required	711C	716C	
	DW610, DW616, DW618	Not Required	711C	716C	
	DW613, DW615(UK)	710	711C	716C	
ELU	DW614, DW615, DW621, DW624, DW625, DW626	N. America Only, Supplied w/router	711C	716C	
	DW621K, DW622 and DW626 outside N. America	706R	711C	716C	
	DW625 Type 1, 2, 3, 5 outside N. America	702	711C	716C	
	DW624 & DW625 Type 4 outside N. America, DW625EK	702R	711C	716C	
	OF15, OF15E, OF97, OF97E	706R	711C	716C	
FEIN	MOF68, MOF69, MOF96, MOF96E	710	711C	716C	
	MOF131, MOF177 Type 1, 2, & 3	702	711C	716C	
	MOF177 Type 4, MOF177EK	702R	711C	716C	
	2720, 2721, 3328	Not Required	711C	716C	
	3303, 3304	E09600 or 761 270-00	711C	716C	
FESTOOL	3337, 3338, 3339	702	711C	716C	
	RT1800	Supplied w/router	711C	716C	
	OF1E, OF2E, OF650, OF900E, OF1000, OF1010E	704R	711C	716C	
FREUD	OF2000, OF2000E	705R	711C	716C	
	OF1400 and OF2200 North America Only	Supplied w/router	711C	716C	
	OF1400 Outside North America	493566	711C	716C	
	OF2200 Outside North America	494627 O-Ring may be required to keep bushing centered	711C	716C	
HITACHI	FT1700(2), FT2000, FT2200, FT3000	721	711C	716C	
	TR8, TR12, FM8, M8, M12 Series	325211 OR 703	711C	716C	
	M12VC, KM125C, KM12VC	Not Required	711C	716C	
MAFELL	M12SA2, M12V2	325224	711C	716C	
	LO65E	702 ■	711C	716C	
MAKITA	M363, MRP090, RP1800(F), RP1801(F), RP2300(FC), RP2301(FC), 3612C Europe Ok Fit Base	721	711C	716C	
	3600, 3606, 3608, 3612, 3612B, 3612BR, 3612C N. America, 3620, 3621, RP0900, RP900K	703	711C	716C	
	3601B	321 493-1	711C	716C	
	RP0910, RP1110C	706R	711C	716C	
MASTERCRAFT	RF1100, RF1101, RD1100, RD1101, RP1101	Not Required	711C	716C	
	Please contact Leigh for assistance				
METABO	OF1612, OFE1812 (for all others, please contact Leigh for assistance)	704R	711C	716C	
	5615, 5616, 5619	49-54-1040 (replacement base)	711C	716C	
MILWAUKEE	5625	49-54-1026 (replacement base)	711C	716C	
	5670	Not Required	711C	716C	
PEARLES	OF808 Series, OFE6990	710	711C	716C	
PORTER CABLE (ROCKWELL)	All	Not Required or Supplied w/router	711C	716C	
RIDGID	R2930 (for all others, please contact Leigh for assistance)	704R	711C	716C	
	R30, R50, R150, R151, RE155, R500, R501, R502	703	711C	716C	
RYOBI	R600, R601, RE600, RE601	702	711C	716C	
	R160, R161, R162, R163K, R165, R170, R175, RE175, R180, R180PL, R181, R185, ERT1150	706R	711C	716C	
	1823 or 1835	91803	711C	716C	
SKIL	SK1810, 1815, 1820, 1825	RAS140	711C	716C	
	All others	Aftermarket base plate required	711C	716C	
TREND	T3, T4, T5, T9, T10, T11 – UniBase required	710	711C	716C	
TRITON	TRC001	TGA006 or 704R	711C	716C	
	JOF001, MOF001, TRA001	Accessory Kit (includes adaptor) TGA001 or TGA150	711C	716C	
WEGOMA	OF850 Series	710	711C	716C	



*M2 – APPENDIX II*

---

## **Parts List**

*Appendix II M2 User Guide*

**NOTE:** When ordering parts, please quote the product model, serial number (on underside of fence scales), part number, part description and quantity required.

<b>PART NO.</b>	<b>QUANTITY</b>	<b>DESCRIPTION</b>
31	1	M2 User Guide
180	1	1/2" [12,7mm] Spiral Upcut Bit, HSS
441	1	Guide Rail
451	1	Finger Guide Rail
480	10	Right Hand Finger Bevel Nut
490	10	Left Hand Finger Bevel Nut
7225R	20	Finger Lock Screw
600	10	Right Hand Finger c/w Bevel Nut and Screw
610	10	Left Hand Finger c/w Bevel Nut and Screw
620	1	Right Hand Support Bracket
630	1	Left Hand Support Bracket
641M	1	Millimeter Right Hand Finger Scale Assembly, complete
641	1	Inch Right Hand Finger Scale Assembly, complete
651M	1	Millimeter Left Hand Finger Scale Assembly, complete
651	1	Inch Left Hand Finger Scale Assembly, complete
3110R	4	8-32 x 1/2" Hex Socket, Flat Point Set Screw (Scale Lock)
3156	1	5/64" Hex Key (or 2mm)
671	1	Right Hand Fence Scale, complete
681	1	Left Hand Fence Scale, complete
690	1	Fence Assembly c/w Alloy Plugs
695	2	Side Stop Extension

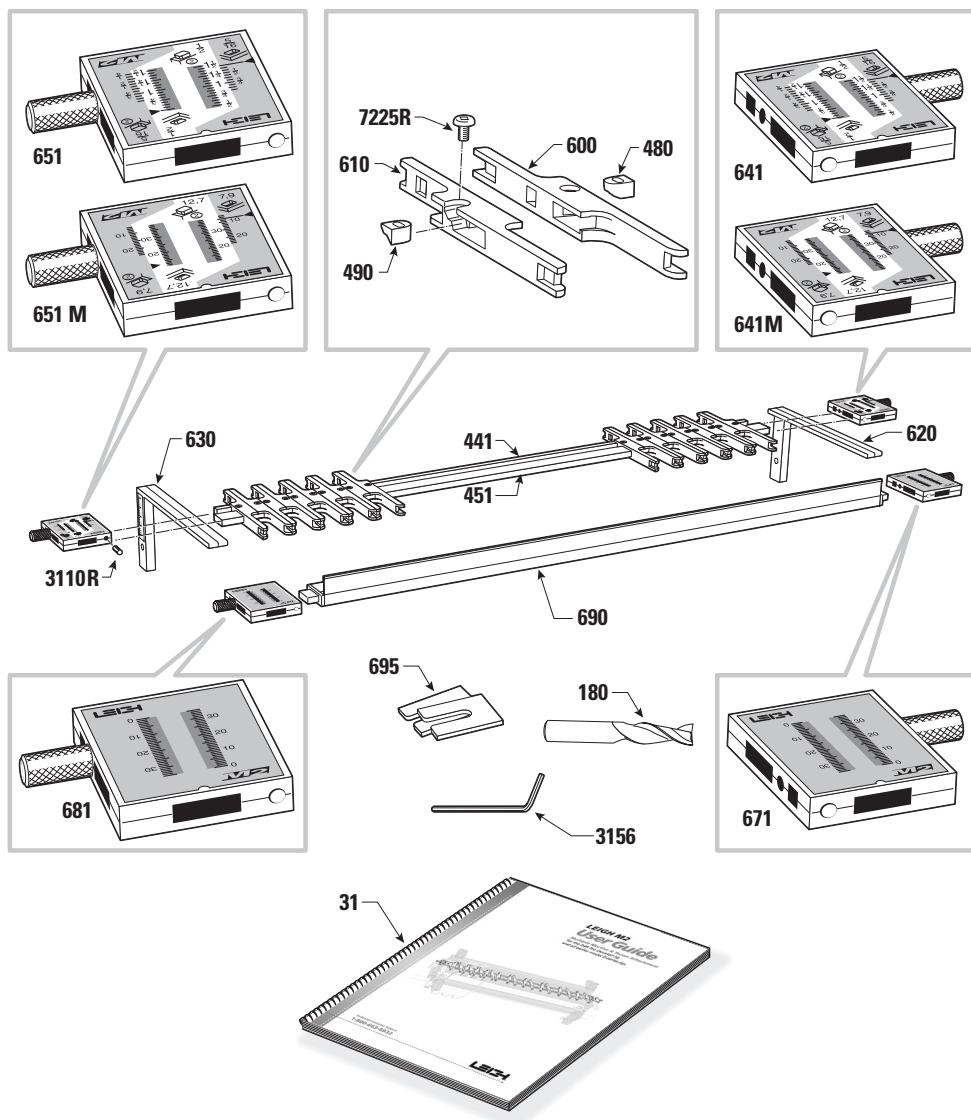



*M2 – APPENDIX III*

---

# **Customer Support**

## Appendix III M2 User Guide

**Customer Support Our Commitment to You** Leigh Industries takes pride in its commitment to providing excellence in customer service and support. This user guide is designed to provide you with the answers to any questions you have. However, if you require assistance, please feel free to contact our technical support staff or a distributor listed below.

### Manufacturer: Canada/USA

LEIGH INDUSTRIES LTD. (est. 1981)  
P.O. Box 357  
1615 Industrial Ave.  
Port Coquitlam, B.C.  
Canada, V3C 4K6

**Toll Free:** 800-663-8932 (Can/USA)  
**Phone:** 604-464-2700  
**Fax:** 604 464-7404  
**Cust. Service:** leigh@leighjigs.com  
**Tech Support:** help@leighjigs.com  
**Web Site:** www.leighjigs.com

**NOTE:** Email can be useful, but technical queries usually raise queries from us. A phone call is the quickest, most convenient way to get queries answered; either directly to Leigh (toll-free in N. America) or to your national distributor. – *Thanks!*

### Distributors

#### AUSTRALIA & NEW ZEALAND

Carbatec  
128 Ingleston Rd., Wakerley, Qld., 4154  
Australia  
Tel: (07) 3390 5888  
Fax: (07) 3890 5280  
Order: 180 658 111  
Email: orders@carbatec.com.au  
Web: www.carbatec.com.au

#### CHINA

Harvey Industries Co., Ltd.  
68-10 Suyuan Avenue  
Jiangning District Nanjing 211100, China  
Tel: (0)86 5792 8869 / 5792 8021  
Fax: (0)86 5792 8826  
Email: caozhi@harvey.cn  
Website: www.harveyworks.cn

#### FRANCE

Ets Bordet  
23 Rue Traversiere  
93556 Montreuil Cedex, France  
Tel: 01 48 58 28 39  
Fax: 01 48 58 48 58  
Email: info@bordet.fr  
Web: www.bordet.fr

#### GERMANY, AUSTRIA & SWITZERLAND

Hacker GmbH  
Holzbearbeitungsmaschinen  
Traberhofstraße 103 D-83026 Rosenheim,  
Deutschland  
Tel: 08031 269650  
Fax: 08031 68221  
Email: hacker.rosenheim@t-online.de  
Web: www.leigh.de

#### ITALY

Ferrari Macchine Legno SRL  
Via Gallarata 74/76/78  
20019 Settimo M.se (MI) Italy  
Tel: 39 02 335 010 95  
Fax: 39 02 335 005 27  
Email: info@ferrarimacchine.com  
Web: www.ferrarimacchine.com

#### JAPAN

Off Corporation Inc.  
323-1 Yanbara, Shimizu-ku, Shizuoka-shi  
Shizuoka-ken, Japan 424-0002  
Tel: 81-50-3816-0115  
Fax: 81-54-367-6515  
Email: info@off.co.jp  
Web: www.off.co.jp

#### KOREA

Leigh Korea  
1st Floor, Yongyu Building, 25-3,  
Neung Pyung-Ri, Opo-Eup, Kwangju-Si,  
Kyunggi-do, Korea  
Tel: 82 (0) 70-8252-0988  
Fax: 82 (0) 31-765-5602  
Email: maengha@leigh.co.kr  
Web: www.leigh.co.kr

#### NETHERLANDS, BELGIUM & LUXEMBOURG

Houtbewerking Krielaart  
9217RR Nijega,  
Netherlands  
Tel: +31 512 354 770  
Email: gerard@gkrielaart.nl  
Web: http://www.leighjigs.nl

#### RUSSIA

Unicom Ltd.  
Nikitskij Boulevard 12  
Moscow, 119019, Russia  
Tel: 7 (495) 690 0454  
Email: info@leighjigs.ru  
Web: www.leighjigs.ru

#### SOUTH AFRICA

Hardware Centre  
PO Box 4059, Randburg 2125  
South Africa  
Tel: +27 011 791-0844/46  
Fax: +27 011 791-0850  
Email: info@hardwarecentre.co.za  
Web: www.hardwarecentre.co.za

#### SWEDEN

Toolbox Sweden AB  
Bruksgatan 3, S-597 30  
Atvidaberg, Sweden  
Tel: 46 120 854 50  
Fax: 46 120 854 69  
Email: info@toolbox.se  
Web: http://www.toolbox.se

#### UNITED KINGDOM & IRELAND

Axminster Tools & Machinery,  
Headquarters  
Unit 10, Weycroft Avenue  
Axminster, Devon  
EX13 5PH United Kingdom  
Tel: 0800 371822  
Text: 07786 200699  
Email: cs@axminster.co.uk  
Web: www.axminster.co.uk/leigh





---

Printed in Canada