

# **LEIGH RTJ400**

*16" Router Table Dovetail Jig*

# **User Guide**

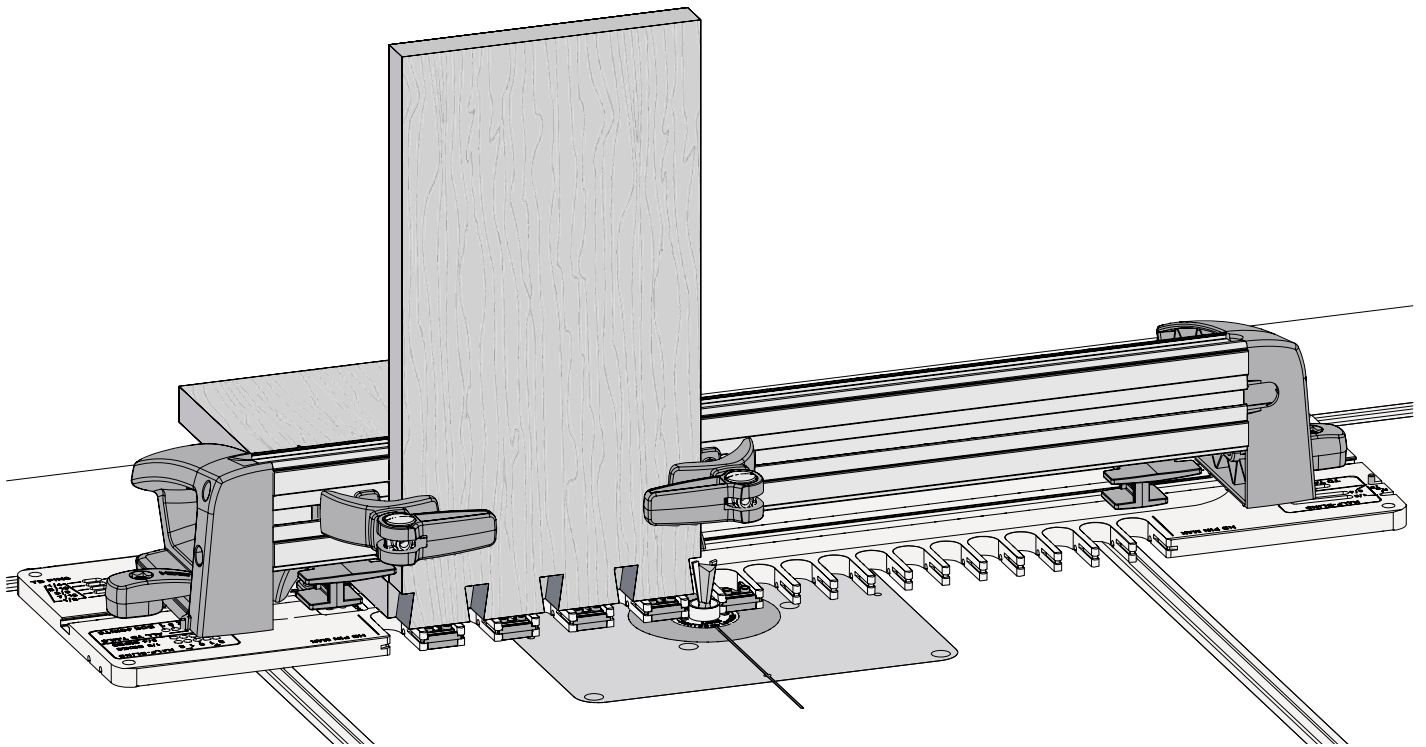

Dedicated Customer Support  
**1-800-663-8932**



## Your New Leigh RTJ400 Router Table Dovetail Jig for Through Dovetails, Half-Blind Dovetails and Box Joints

The RTJ400 was designed for the ever increasing use of router tables in shops everywhere. The RTJ400 can produce sizes and types of joints not possible with typical template jigs, including through dovetails, half-blind dovetails and box joints (finger joints), and thanks to the patented Leigh eBush, perfect fitting joints are guaranteed every time.

### Customer Support

If you have any questions that are not answered in this user guide, please call Leigh Customer Support: **1-800-663-8932** in North America or email: [help@leighjigs.com](mailto:help@leighjigs.com). For support contacts in your country of purchase, see Customer Support, Chapter 15. Leigh user guides are updated as required. A downloadable pdf of the latest version can be found on the Support page at [leighjigs.com](http://leighjigs.com).

*Reminder: If at first you don't succeed, read the instructions!*

### Important! Inches and Millimeters

Text and illustrations in this English language user guide indicate dimensions in both inches and millimeters, where applicable, with “inches” first, followed by “millimeters” in square brackets, i.e. ½" x 2" [12mm x 50mm].

**Do not be concerned that the inch/millimeter equivalents are not mathematically “correct”. Just use the dimensions that apply to your guides and bits.**

The RTJ400 is covered by the following patent: U.S. Patent No. 8,534,329  
Patents for all Leigh elliptical guide bushings: U.S. 8,256,475 UK GB2443974

## Contents

Dedicated Customer Support  
**1-800-663-8932**

	<b>Introduction</b>	2
	Jig Features	3
	Bit Specifications	4
	Accessory Kit for the RTJ400	5
	Router Table Requirements	6
Chapter 1	<b>Assembling the RTJ400</b>	7
Chapter 2	<b>Glossary of Symbols</b>	11
Chapter 3	<b>Using your Jig Safely</b>	13
Chapter 4	<b>Basic Jig Functions</b>	15
Chapter 5	<b>Wood Preparation</b>	19
Chapter 6	<b>The Leigh eBush</b>	21
Chapter 7	<b>Through Dovetails</b>	23
Chapter 8	<b>Half Pitch Through Dovetails</b>	29
Chapter 9	<b>Half-Blind Dovetails</b>	35
	Rabbeted Half-Blind Dovetails	40
Chapter 10	<b>3/8" Box (Finger) Joints</b>	43
	3/8" Half-Blind Box Joints	48
Chapter 11	<b>3/4" Box (Finger) Joints</b>	53
Chapter 12	<b>3/16" Box (Finger) Joints</b>	59
Chapter 13	<b>3/32" Box (Finger) Joints</b>	65
Chapter 14	<b>Jig Parts</b>	71
Chapter 15	<b>Customer Support</b>	73
Chapter 16	<b>Quick Reference</b>	74
	Board Width Selection	74

### IMPORTANT Jig Design Update

The drawings in this user guide show an earlier version of the jig handles (A). The handles now have two protrusions to protect the pin (B). The functionality remains the same.

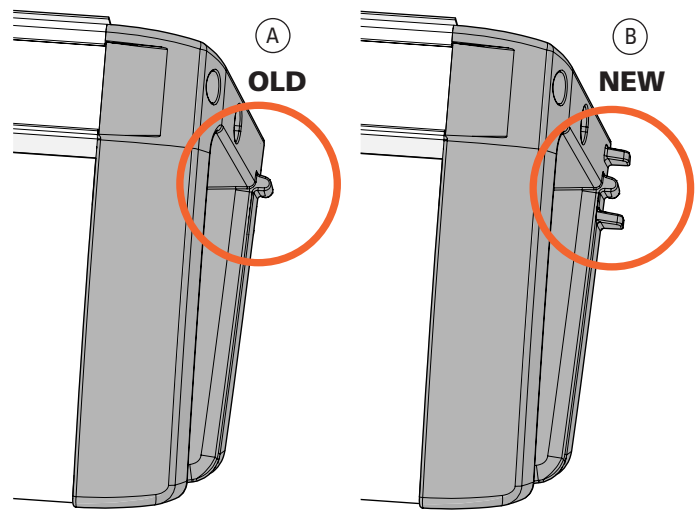

Overhead view of old and new handles.

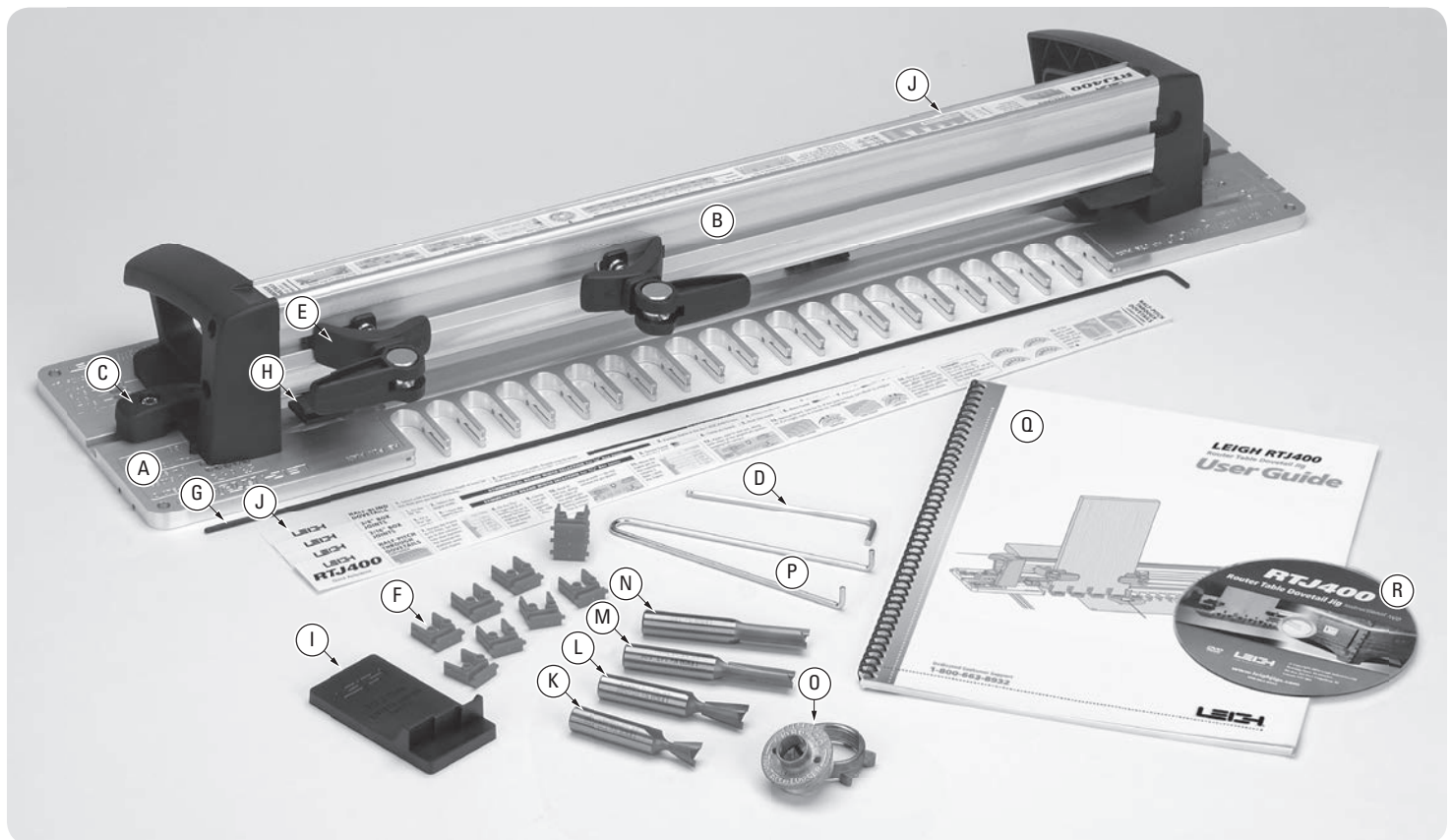

## RTJ400 Jig Features and Parts

See complete list of jig parts in Chapter 14.

*If any of these parts are missing from your jig, please notify your supplier or Leigh immediately. See Chapter 15, Customer Support.*

- Ⓐ **Jig Template**, CNC machined, with holes and slots to position the frame, and precision guides for routing tails, pins & sockets
- Ⓑ **Jig Frame**, CNC machined, with pins that fit into template holes & slots
- Ⓒ **Frame Latches**, 2, to secure jig frame to jig template
- Ⓓ **Hex Key**, 1/8" Ball End
- Ⓔ **Cam-Action Speed-Clamps**, 4, for mounting workpieces to jig
- Ⓕ **Blockers**, 10, inserted in template guide openings to prevent routing
- Ⓖ **Stop Rod**, inserted in template holes to limit cutting depth
- Ⓗ **Side stops**, 2, for mounting workpieces; adjustable for all joint types
- Ⓘ **Bit Depth Gauge**, for setting cutting depth on half-blind dovetails
- Ⓙ **Instruction Strips**, 5, for quick reference; inserted in jig top
- Ⓚ **Dovetail Bit 120-500**, 1/2" x 1/2" x 14°
- Ⓛ **Dovetail Bit 80-500**, 1/2" x 13/16" x 8°
- Ⓜ **Straight Bit 143-500**, 3/8" x 1-1/4"
- Ⓝ **Straight Bit 160**, 1/2" x 1-1/4"
- Ⓞ **Guide Bushing**, e10 Elliptical eBush, for perfect joint fit
- Ⓟ **Pin Wrench**, to adjust e10 eBush
- Ⓠ **User Guide**, Fully Illustrated. **Note:** PDF of User Guide included on DVD
- Ⓡ **DVD Video**, Instructional

### You will need:

- A router table that accepts standard size (1-3/8" OD) guide bushings

**Note:** See page 6 for instructions on fitting the Leigh eBush to your router table.

## Bits for the RTJ400

This chart shows all bits available for the RTJ400.

RTJ400 BIT SPECIFICATIONS											
Leigh Bits	A Bit Diameter	B Max. Cutting Depth	C Shank Diameter	D Shank Length	E Overall Length	F Angle	Use with Collet/Collet Reducer	Full Pitch Through Use with Straight Bit	Use with e-Bush	Half Pitch Through Use with Straight Bit	Use with e-Bush
<b>Through Dovetails</b>											
<b>50-8</b> Carbide Tipped	1/4"	1/4"	8mm	1-3/4"	2"	8°	8mm collet or 172-8 collet reducer	160 180 180C	e10	140-8 170 170C	e7 & e10
<b>60-8</b> Carbide Tipped	5/16"	3/8"	8mm	1-3/4"	2-1/8"	8°	8mm collet or 172-8 collet reducer	160 180 180C	e10	140-8 170 170C	e7 & e10
<b>70-8</b> Carbide Tipped	3/8"	1/2"	8mm	1-3/4"	2-1/4"	8°	8mm collet or 172-8 collet reducer	160 180 180C	e10	140-8 170 170C	e7 & e10
<b>75-8</b> Carbide Tipped	7/16"	5/8"	8mm	1-3/4"	2-3/8"	8°	8mm collet or 172-8 collet reducer	160 180 180C	e10	140-8 170 170C	e7 & e10
<b>80-500*</b> Carbide Tipped	1/2"	13/16"	1/2"	1-3/4"	2-3/4"	8°	1/2" collet	160 180 180C	e10	-	-
<b>140-8</b> Carbide Tipped	5/16"	1-1/4"	8mm	1-3/4"	2-3/4"	-	8mm collet or 172-8 collet reducer	-	e7	-	-
<b>170*</b> High Speed Steel	5/16"	1"	8mm [5/16"]	1-3/4"	3"	-	8mm collet or 172-8 collet reducer	-	e7	-	-
<b>170C*</b> Solid Carbide	5/16"	1-1/4"	8mm [5/16"]	1-3/4"	2-3/4"	-	8mm collet or 172-8 collet reducer	-	e7	-	-
<b>160*</b> Carbide Tipped	1/2"	1-1/4"	1/2"	1-3/4"	3"	-	1/2" collet	-	e10	-	-
<b>180*</b> High Speed Steel	1/2"	1-1/4"	1/2"	1-3/4"	3-1/2"	-	1/2" collet	-	e10	-	-
<b>180C*</b> Solid Carbide	1/2"	1-1/4"	1/2"	1-3/4"	3-1/2"	-	1/2" collet	-	e10	-	-
<b>Half-Blind Dovetails</b>											
<b>112-500</b> Carbide Tipped	1/2"	19/32"	1/2"	1-3/4"	2-9/16"	12°	1/2" collet	-	e10	-	-
<b>120-500*</b> Carbide Tipped	1/2"	1/2"	1/2"	1-3/4"	2-1/2"	14°	1/2" collet	-	e10	-	-
<b>128-500</b> Carbide Tipped	1/2"	3/8"	1/2"	1-3/4"	2-3/8"	18°	1/2" collet	-	e10	-	-
<b>Box Joints</b>											
<b>163</b> High Speed Steel	3/32"	3/8"	1/4"	2"	2"	-	1/4" collet	-	e10	-	-
<b>166*</b> High Speed Steel	3/16"	5/8"	1/4"	1-3/4"	2-7/8"	-	1/4" collet	-	e10	-	-
<b>166C*</b> Solid Carbide	3/16"	5/8"	1/4"	1-3/4"	2-1/2"	-	1/4" collet	-	e10	-	-
<b>143-500*</b> Carbide Tipped	3/8"	1-1/4"	1/2"	1-3/4"	3-1/4"	-	1/2" collet	-	e10	-	-
<b>173-500*</b> High Speed Steel	3/8"	1-1/4"	1/2"	1-3/4"	3-3/4"	-	1/2" collet	-	e10	-	-
<b>173-500C*</b> Solid Carbide	3/8"	1-1/4"	1/2"	1-3/4"	3"	-	1/2" collet	-	e10	-	-
<p>* Bits 80-500, 160, 120-500 &amp; 143-500 come with the RTJ400</p> <p>* Spiral upcut bits rout cleaner and faster, leaving a smoother finish</p>											
<b>172-8</b> 1/2" to 8mm collet reducer 1 1/4" long. For 8mm shank bits											

## Accessory Kit for the RTJ400 (ACRTJ)

This optional kit offers great savings over individual prices, and opens up a world of possibilities. Available from leighjigs.com

### The ACRTJ includes:

#### Through Dovetail Bits

Carbide tipped, 8°, 8mm shank, for through and half pitch through dovetail tails

- 50-8** 1/4" bit
- 60-8** 5/16" bit
- 70-8** 3/8" bit
- 75-8** 7/16" bit

#### Straight Bit for Half Pitch Dovetails

Carbide tipped, 8mm shank, for half pitch through dovetail pins

- 140-8** 5/16" bit

#### Half-Blind Dovetail Bits

Carbide tipped, for half-blind dovetails

- 112-500** 12° 1/2" bit
- 128-500** 18° 1/2" bit

#### Straight Bits for Box Joints

High speed steel, for box joints

- 163** 3/32" bit
- 166** 3/16" bit (spiral upcut)

#### Collet Reducer

For 8mm shank bits

- 172-8** 1/2" to 8mm, 1-1/4" long

#### Guide Bushing

For half pitch through dovetail pins

- e7** Leigh elliptical eBush



## Router Table Requirements

Router tables are typically used with a bearing or fence, however, the Leigh RTJ400 is guided around a guide bushing mounted in the router table. Leigh eBushes (guide bushings) are designed around the decades-old Porter Cable/Black & Decker industry standard. Therefore, you will need an insert ring to fit the eBush to your router table or router plate. See specifications below. ■

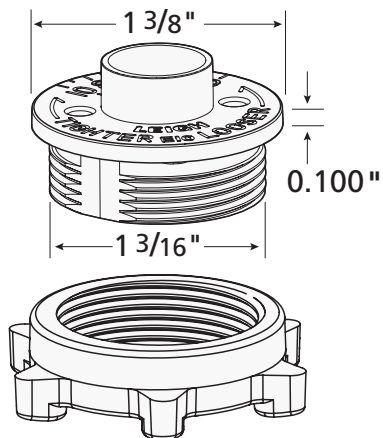

**Leigh eBush and Nut**

To fit the eBush to your router table insert plate, you need a 1-3/8" diameter counter bore insert ring. Check with your router table or insert plate (router lift) manufacturer, as to what adaptation, if any, is required.

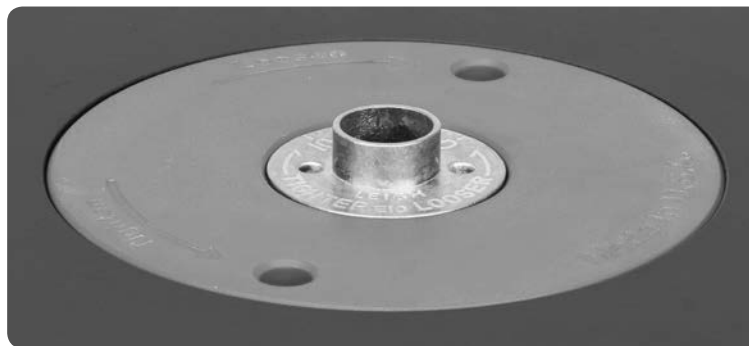
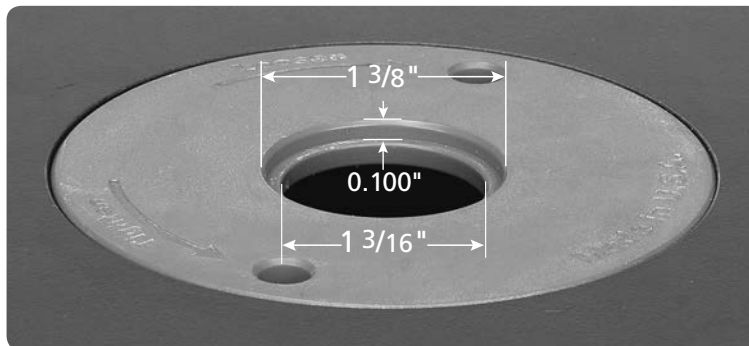

**RTJ400 OPERATION**

**CHAPTER 1**  
**Assembling the RTJ400**

*The following instructions will guide you through the assembly process for the Leigh RTJ400 Router Table Dovetail Jig.*

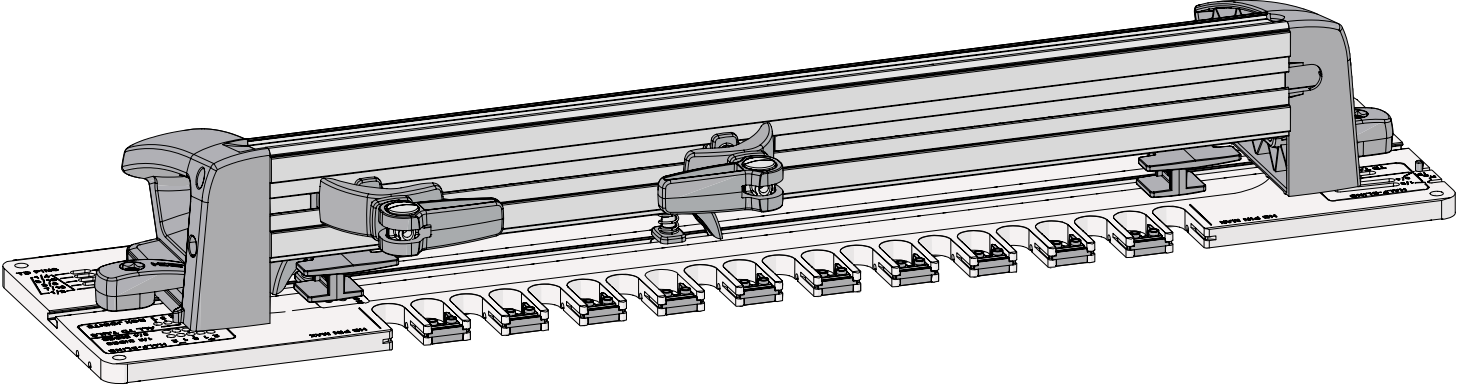
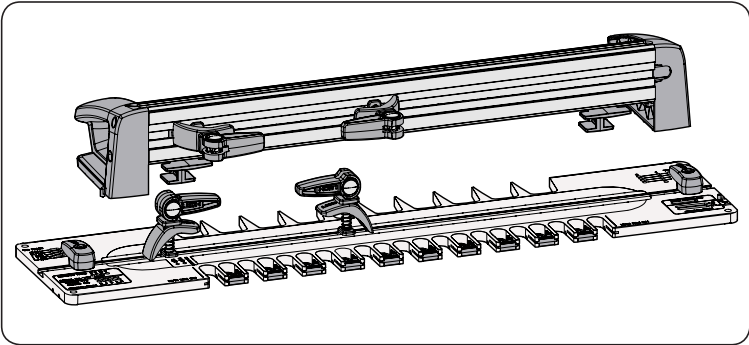

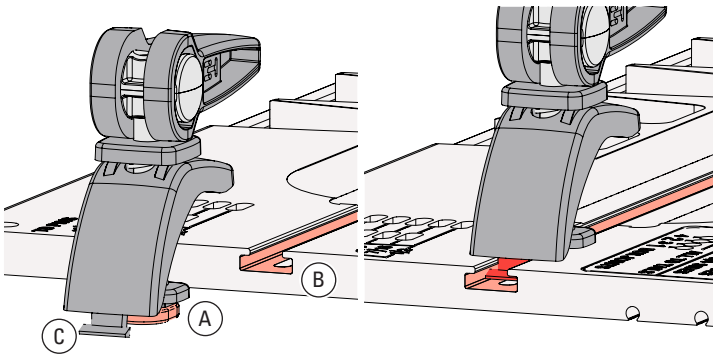

**1-1 Template Clamps:** Insert the clamp T-bolt head (A) into the T-slot at each end of the template (B) followed by the clamp heel (C). Make sure the heels are pointing out at both ends of the template.

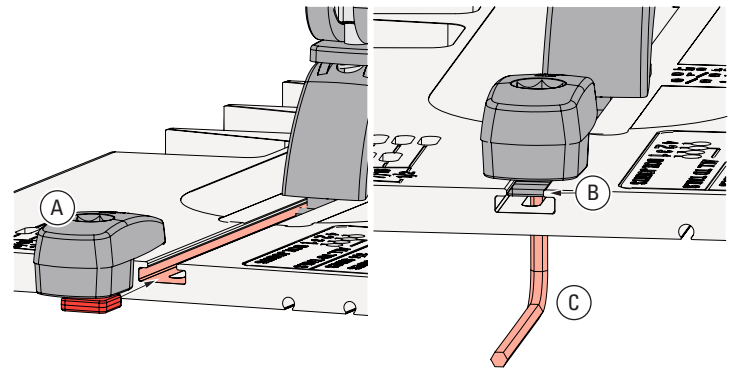

**1-2 Template Latches:** Slide a latch (A) into each end of the template making sure the washer (B) is in the T-slot. Use the hex key (C) through the slot on the bottom of the template to firmly tighten the latches, pulling the hex nuts down into each latch recess. Adjust the latches so they are stiff to slide on the template.

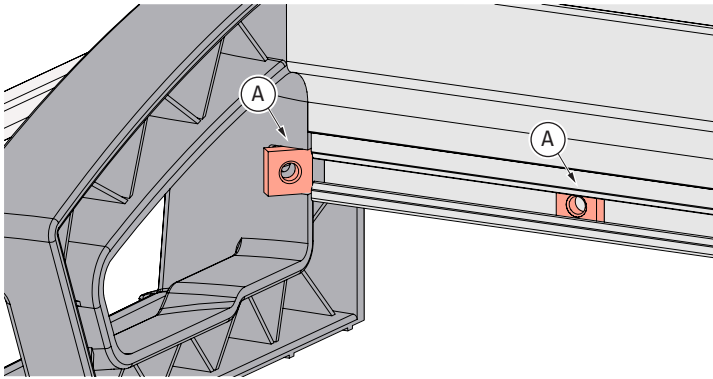

**1-3** Insert the two square nuts into the rear of the frame (A) and slide them to each end of the frame.

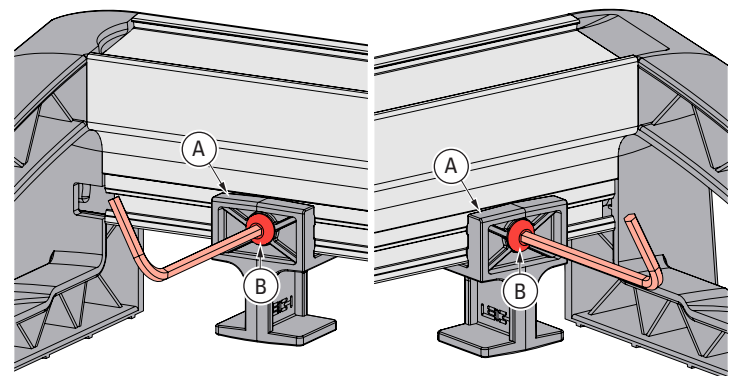

**1-4 Side stops:** Attach the two side stops (A) to the square nuts in the frame using the hex socket button head screws (B), and lightly tighten one side stop at each end of the frame.

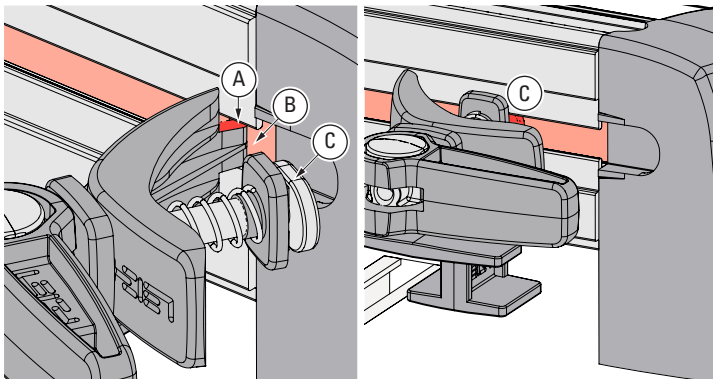

**1-5 Frame Clamps:** Insert the heel (A) of a pre-assembled clamp assembly into the end of the frame T-slot (B) followed by the clamp T-bolt (C), and slide the clamp to the other end of the frame. **Note: The clamp arm spring washers are under tension. They may need to be pulled away from the T-bolt to aid in ease of assembly.**

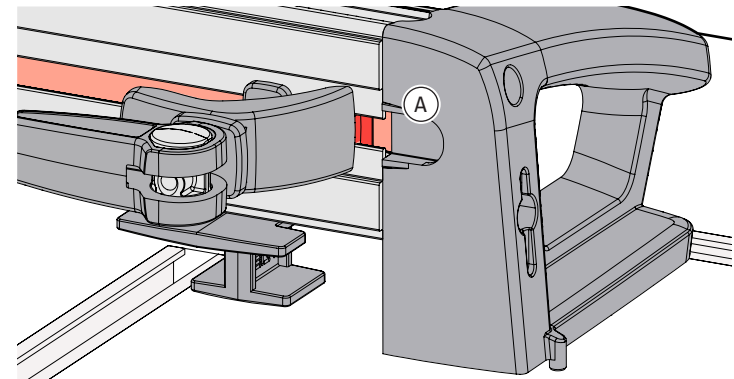

**1-6** When installing the second clamp, insert the T-bolt first and the heel last (A).



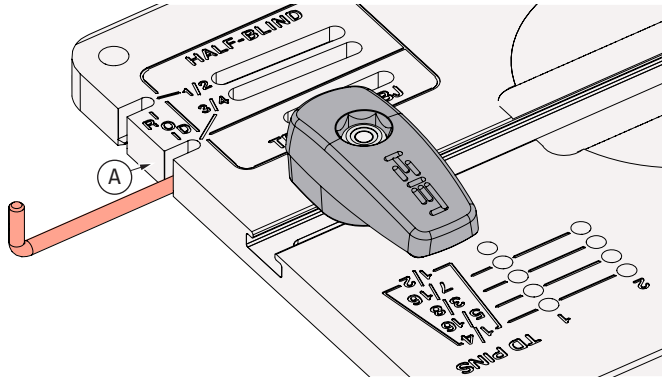

**1-7 Stop Rod:** Insert the stop rod in the 3/4" slot (A). The stop rod remains here for all routing operations except half-blind dovetails and box joints. Note: The stop rod may have been shipped in this location.

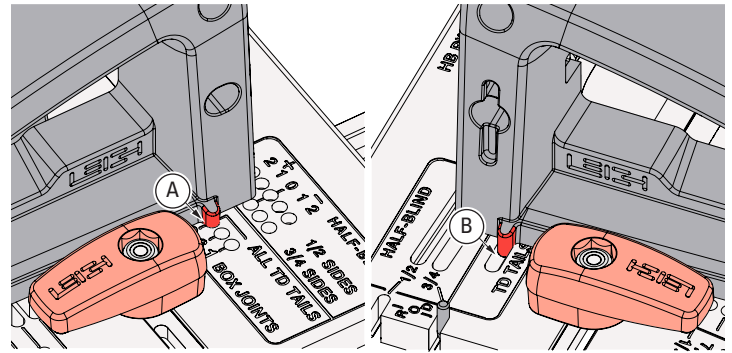

**1-8** The frame is located on the template by a pin on the frame handles. Place the frame on the template by inserting the right frame pin in the **ALL TD TAILS** hole (A) and the left frame pin in the **TD TAILS & BJ** slot (B). **⚠ To prevent damage to the frame pin always remove the right frame pin first when lifting the frame handle.**

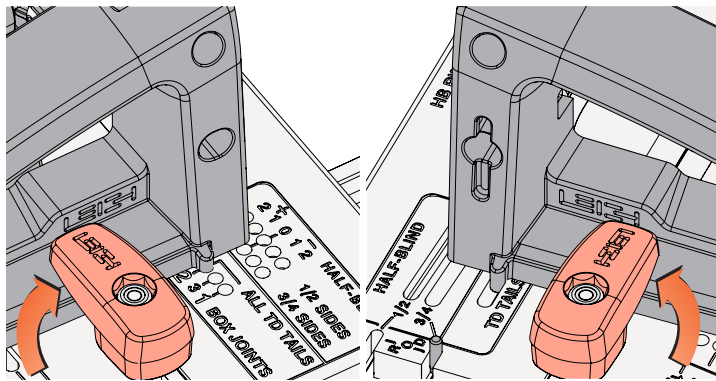

**1-9** Pivot both latches to secure the frame to the template. Double check the latches to ensure they are fully seated. **⚠ Only when the frame is latched securely is it safe to lift and or carry the jig by the handles.**

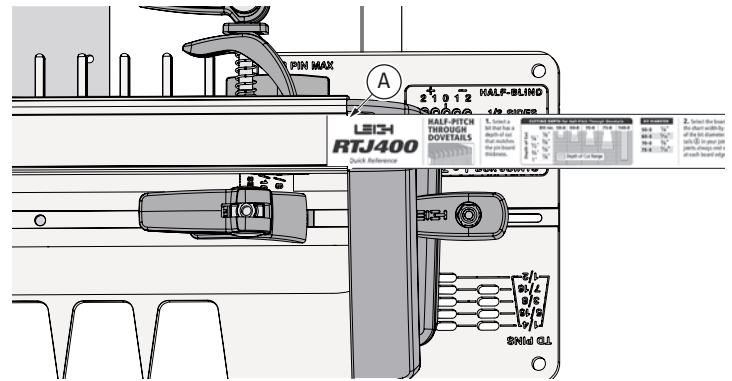

**1-10** If not already in channel, slide the Quick Reference strips into the channel in the top of the jig (A).

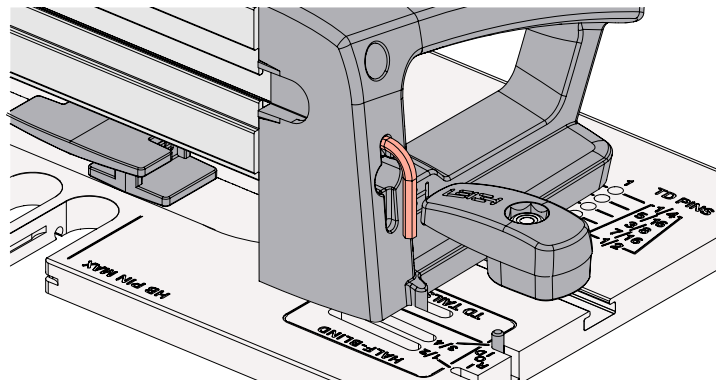

**1-11** Store the hex key in the left hand handle.

**Leftover parts:**

- bit depth gauge
- ten blockers
- e10 guide bushing & nut
- pin wrench
- DVD
- this user guide

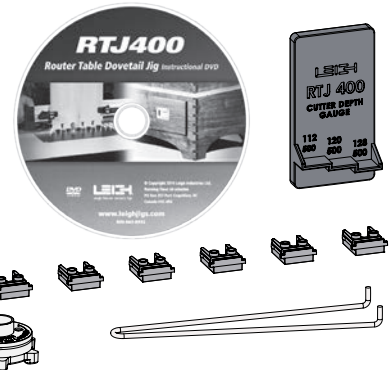

**1-12** You will have leftover parts. Keep them to use as required for various jig operations. ■



## RTJ400 OPERATION











### CHAPTER 2

# Glossary of Symbols

#### Which Way Around Should the Board Go?

The following symbols/icons are used throughout this user guide. They indicate which side of a board faces out when clamped in the jig, and which edge goes against the side stop. They also indicate which faces are in or out when assembled. Dashed line symbols indicate the other side of the board (hidden from view).

**Note:** Before you place the boards in the jig, you must mark them with the appropriate symbols.

-  "Outside" of board
-  "Inside" of board
-  "Either side" of board
-  "Outside" of board (on other side of board)
-  "Inside" of board (on other side of board)
-  "Either side" of board (on other side of board)
-  "This edge" against sidestop
-  "This edge" against sidestop
-  "This edge" against sidestop (on other side of board)
-  "This edge" against sidestop (on other side of board)

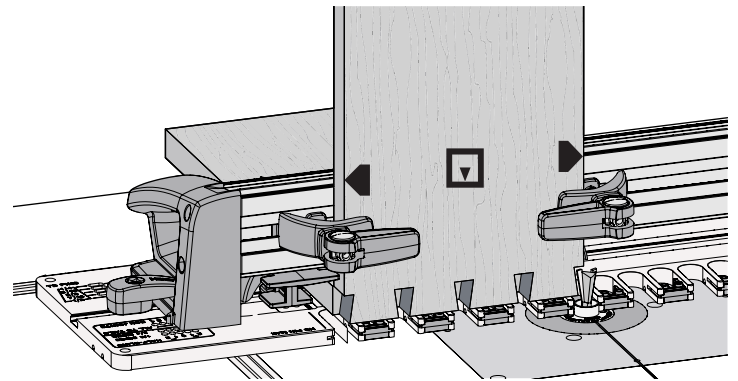

**2-1** Icons such as the one used on the board above indicate which side of the board faces away from the operator when clamped in jig, and which faces are in or out when assembled.

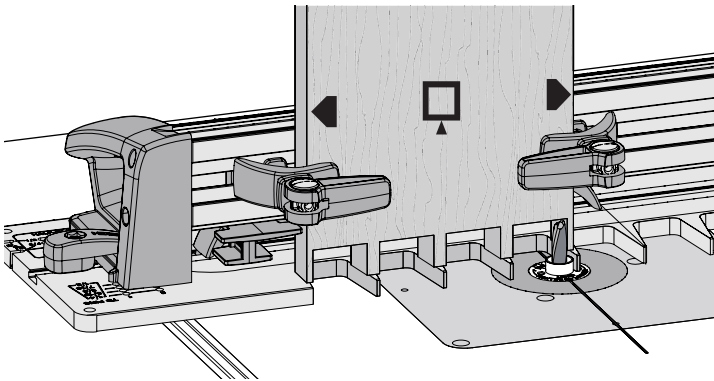

**2-2 Note:** Because through dovetail pin and tail boards are rotated and clamped with the same face against the frame, both side edges are alternately used against the side stop.

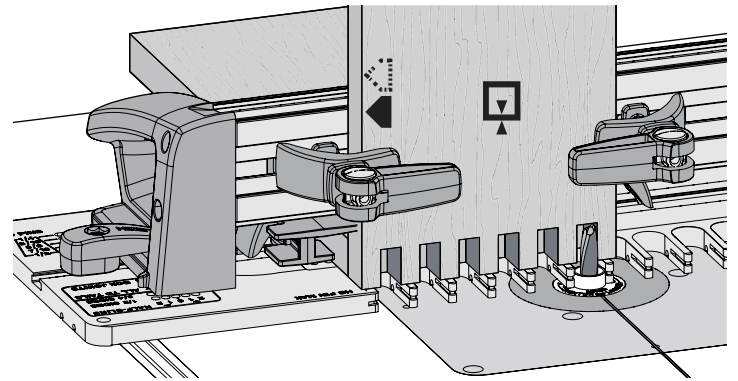

**2-3** Box joint boards are clamped against the frame both face in and face out for alternate end cuts. With box joints, the same side edge always goes against the side stop. ■



## RTJ400 OPERATION

## CHAPTER 3

## Using Your Jig Safely

**Safety is not optional.**

Read and follow the recommendations in this chapter.

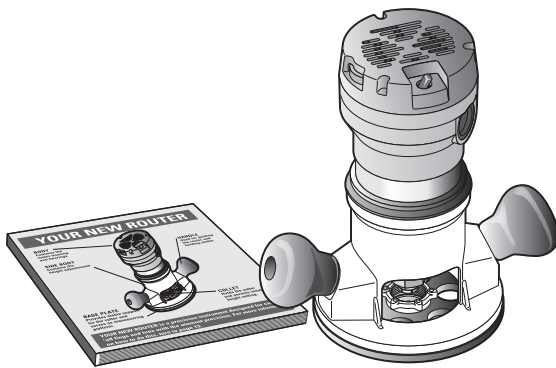

**3-1** Read the owner's user guide that came with your router and router table. It is essential to understand all manufacturer's instructions completely.



**3-2** Always wear:

- approved safety glasses;
- a face mask to protect yourself from harmful dust;
- hearing protection.



**3-3**  Never drink alcohol or take medications that can cause drowsiness while operating a router.

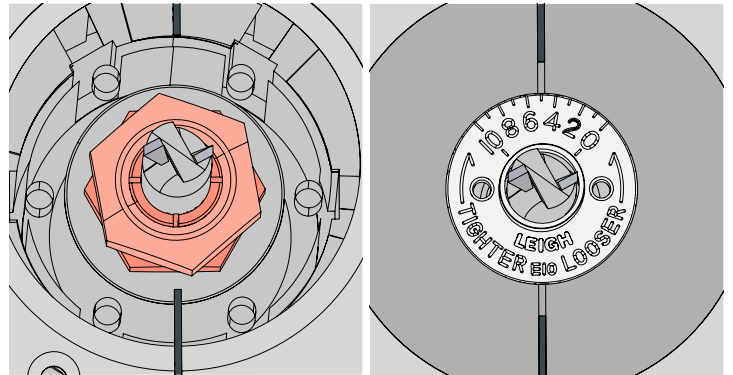

**3-4** Always disconnect the power source and be sure the router has stopped turning before fitting bits, guide bushings or making adjustments. Before reconnecting the router to the power source, make sure the bit and collet revolve freely with and without the guide bushing in place.

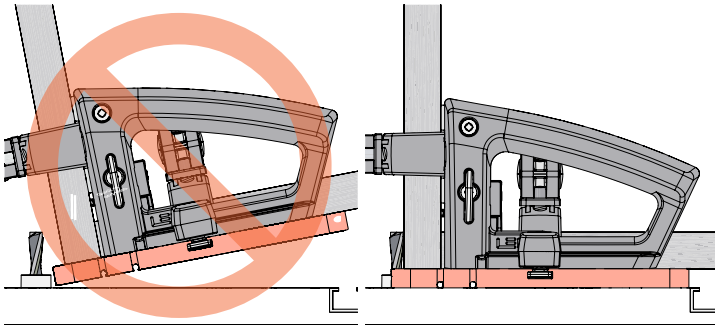

**3-5** Do not tilt the jig. Keep the template flat on the router table at all times.

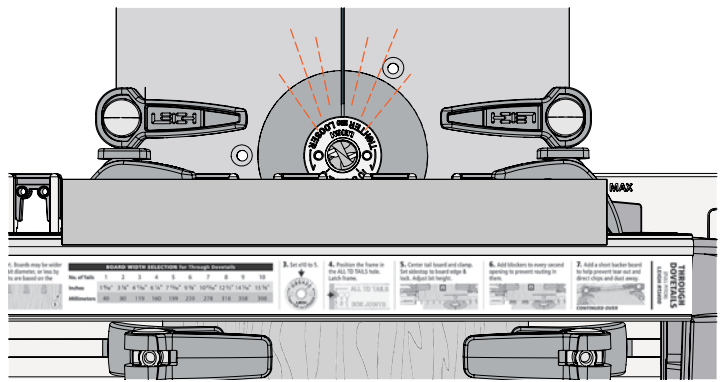

**3-6** Chips and sawdust are thrown out at high speed. Always stand and use the RTJ400 from behind the router bit, opposite to chip and sawdust ejection. ■

## RTJ400 OPERATION

# CHAPTER 4 Basic Jig Functions

Router Table Surface

Template Markings and Orientation

Frame Pin Positioning

Quick Reference Strips

Routing Position

Side stops

Clamping

Backer Board

**IMPORTANT NOTE:** Many of the images in this user guide show the “action” side of the jig, however the operator stands behind the RTJ400, away from the chips and sawdust thrown off by the router bit.

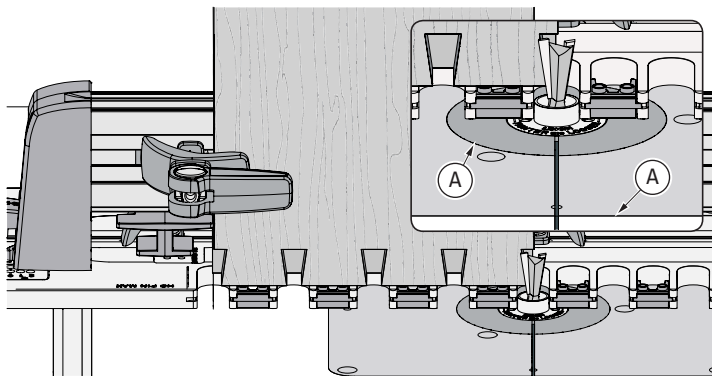

### Router Table Surface

**4-1** Make sure there are no ridges (A) anywhere on the router table surface. The template must slide smoothly over the table top. If the router table is not flat it will have the effect of changing the bit height as the template moves across the table.

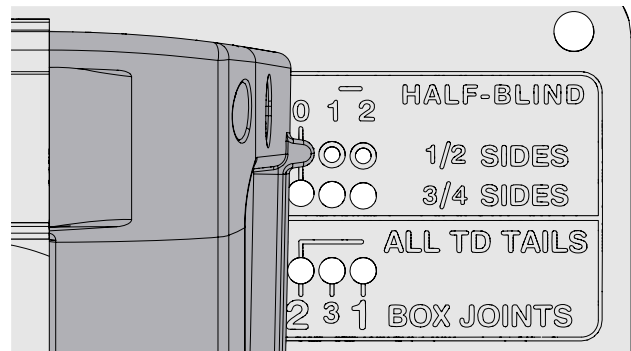

### Template Markings and Orientation

**4-2** The engraved side of the template always faces up. The markings clearly identify which pin hole or slot to position the frame pin into, based on the joint type and size. Joint type determines the orientation of the template, as outlined below.

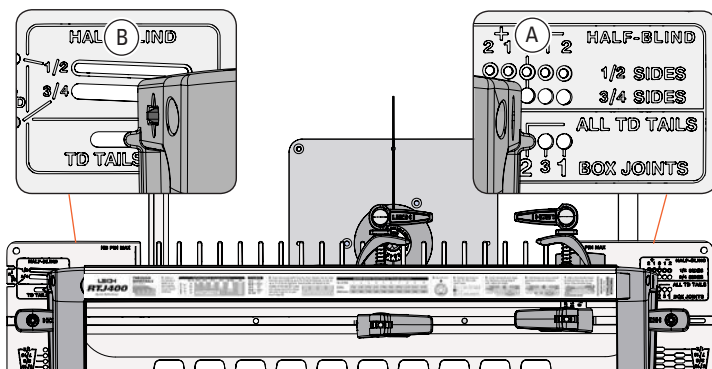

**4-3** The template must be used perpendicular to the line drawn on the table. In this orientation, pin holes (A) and corresponding slots (B) are for half-blind dovetails, through tails and box joints.

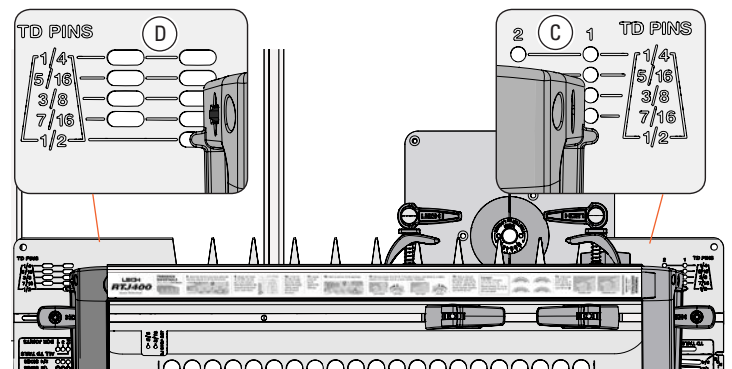

**4-4** In this orientation, pin holes (C) and corresponding slots (D) are for through dovetail pins and half pitch through dovetail pins.

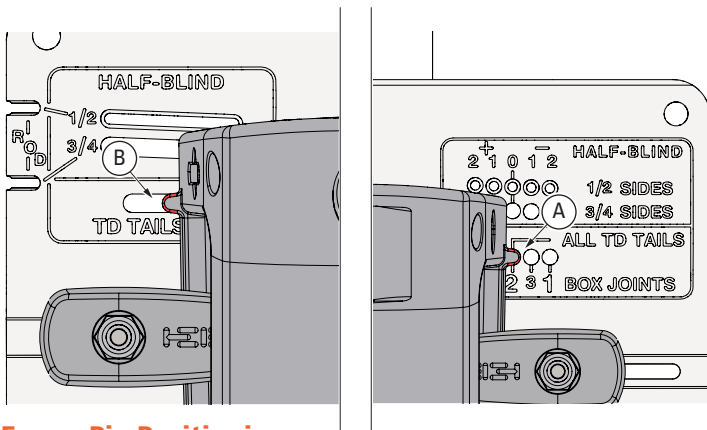

### Frame Pin Positioning

**4-5** The frame is positioned on the template by inserting the frame pins into the pin holes (A) and slots (B). The frame pins are intended to be snug in the template holes. **⚠ To prevent damage to the frame pin always remove the right frame pin first.**

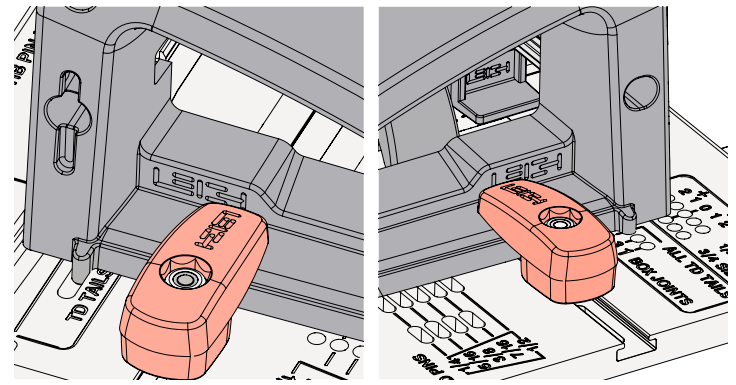

**4-6** **⚠ Be sure to latch the frame securely each time the frame is repositioned.** Only when the frame is latched securely is it safe to lift and or carry the jig by the handles.

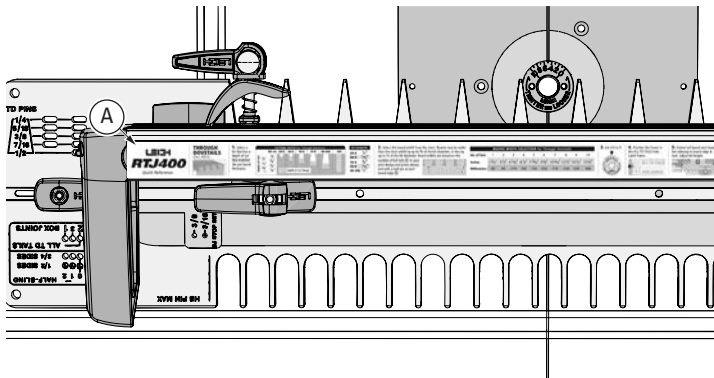

### Quick Reference Strips

**4-7** Quick Reference strips (A) for each joint type are stored in the slot on the top of the jig frame.

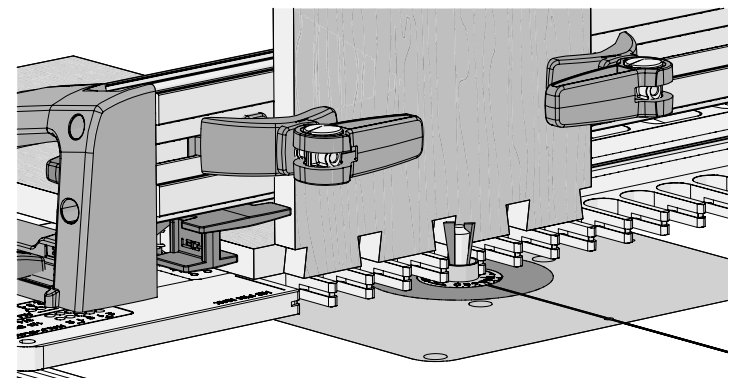

### Routing Position

**4-8** Always use the right-hand side of the jig as shown above, except where specified. **Note: When instructed to rout from right to left, this is from the "operator's" position, standing behind the RTJ400.**

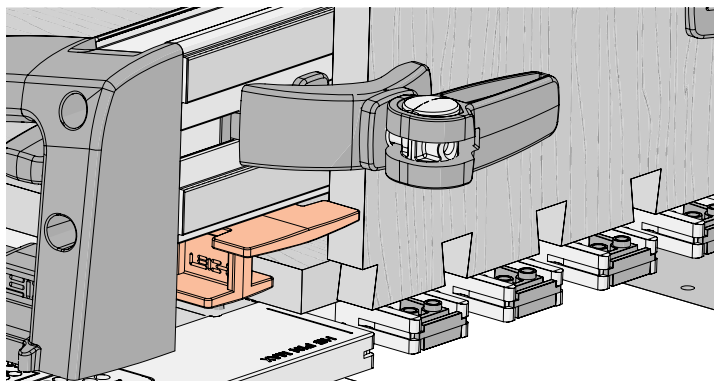

### Side stops

**4-9** The adjustable side stops are user set in a predetermined position for box joints, or positioned against the edge of the workpiece.

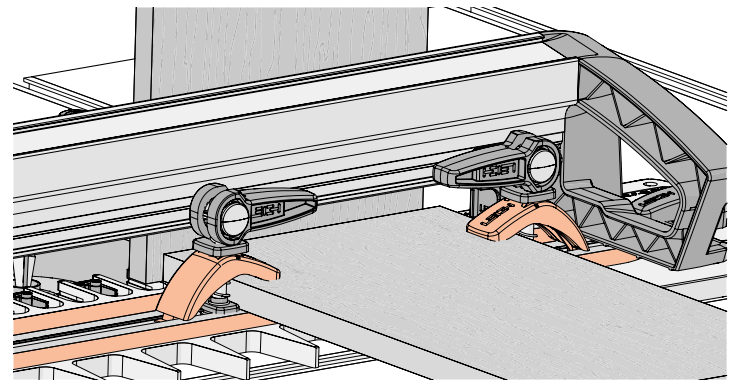

### Clamping

**4-10** Cam-action speed-clamps are exceptionally strong. The clamp arms in conjunction with the machined texturing on the template and frame ensure secure clamping.



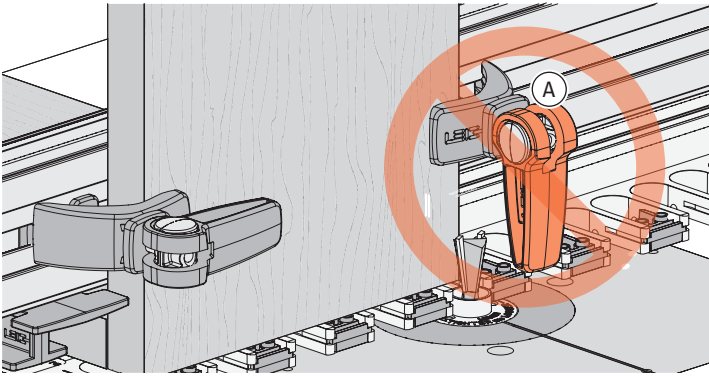

**4-11** ⚠️ *Always ensure that the frame clamp levers do not project below the frame when engaged (A).*

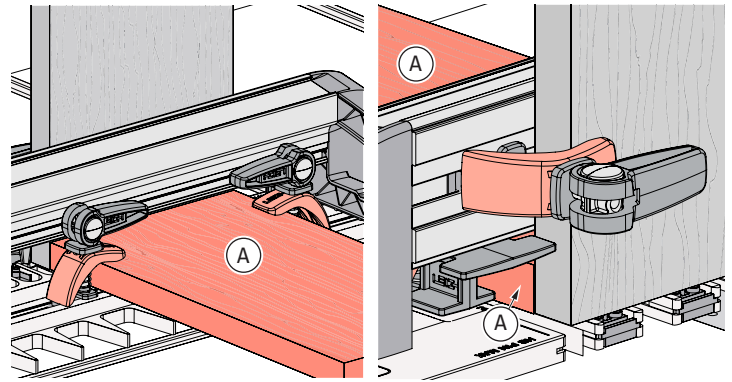

**Backer Board**

**4-12** A short backer board (A) is clamped horizontally behind the tail board, to help prevent tearout, and to direct dust and chips away when routing. ■



## RTJ400 OPERATION

## CHAPTER 5

## Wood Preparation

**Garbage In — Garbage Out**

*This adage of the computer age stands equally true for dovetail joinery.*

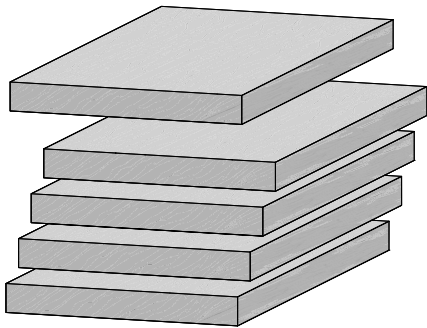

**5-1** Accurate and perfectly aligned joints require stock that is straight, flat, even thickness and equal widths, with square ends and edges. **Note: Plywood is generally unsuitable for routing because of tearout problems.**

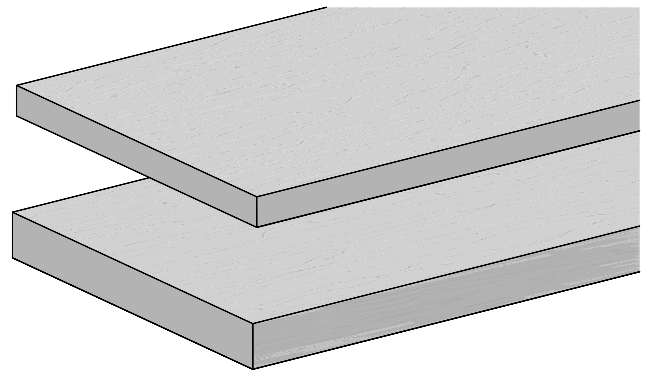

**5-2** You will want to test the jig, so prepare boards of suitable size for the required joint type and size. Use them for practice with the jig's various joint modes so you can see how the different modes work. **Note: Two boards of different thicknesses can be joined as easily as one thickness.**

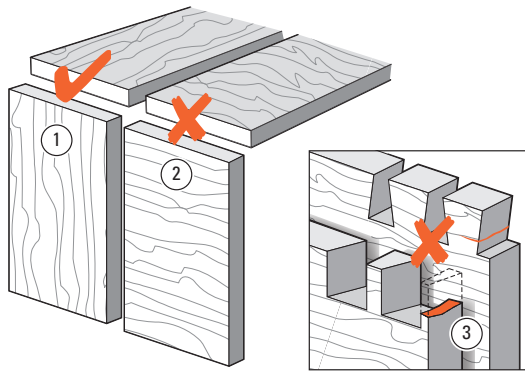

**5-3** ⚠ **Dovetail joints are intended for joining end-grain to end-grain** ①. Dovetails in side-grain ② do not work because the wood will tear out badly when routing and the pins and tails would easily break off ③, either during or soon after the assembly when the boards start expanding or contracting at different rates. ■



## RTJ400 OPERATION

## CHAPTER 6

## The Leigh eBush

**Note: Normal tolerances with bits, guide bushings and router runout will generally produce poor fitting joints. Leigh elliptical guide bushings (e7 and e10) solve this problem.**

Patents for all Leigh elliptical guide bushings: U.S. 8,256,475 UK GB2443974

## Joint Fit Adjustment

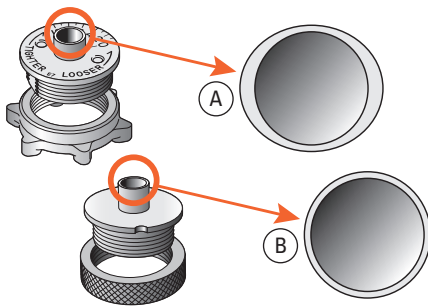

**6-1** The Leigh eBush barrel is elliptical (A), unlike plain circular template guide bushings (B). When rotated, the effective diameter of the barrel changes, allowing fit adjustments as small as 0.001" [0.025mm]. The e10 eBush is included with the RTJ400.

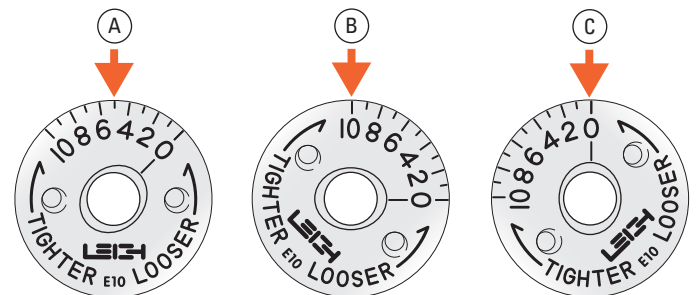

**6-2 All routing starts with the eBush in the No.5 position (A).** Turning the eBush toward the No.10 position (B) results in a tighter fit because the guide bushing is now wider. Turning the eBush toward the No.0 position (C) results in a looser fit.

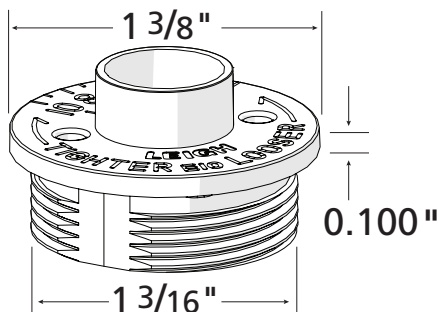

**6-3** The Leigh eBush system is designed around the decades-old Porter Cable/Black & Decker industry standard. Therefore you will likely need to adapt your router table or router table insert plate to accept a Leigh eBush with an insert ring that has a 1 3/8" diameter counter bore. See page 6 for details. Check with your router table or insert plate manufacturer as to what adaptation is required.

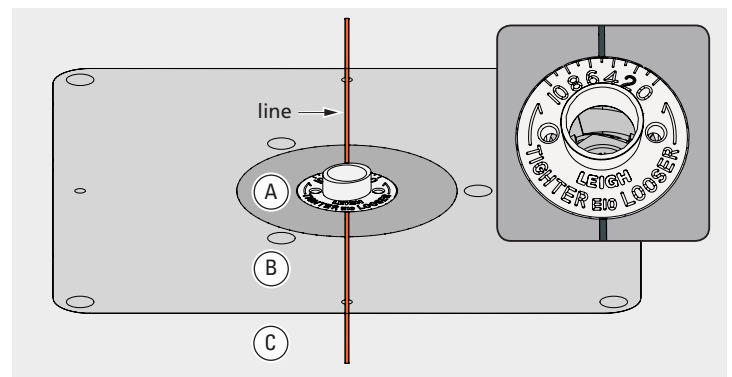

**6-4** Draw a line with a permanent pen on the router table, centered on the guide bushing opening at 12 o'clock and 6 o'clock (shown in red for clarity only). This will ensure correct orientation of the eBush to the insert ring (A), the insert plate (B), and the router table (C).

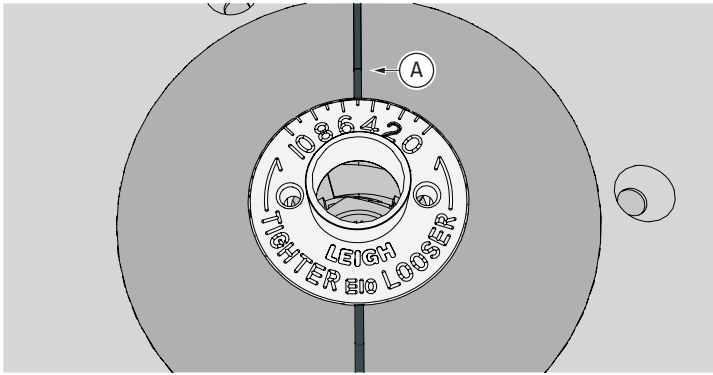

**6-5** All settings for the eBush will be aligned to the line **A** you've drawn on the router table. The line will also help guide the RTJ400.

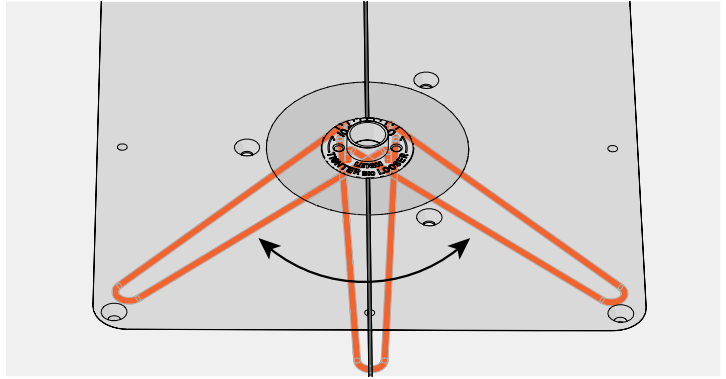

**6-6** Adjust the eBush with the pin wrench. Markings on the eBush indicate which way to turn it for a looser or tighter fit. **Remember, every time you adjust the eBush you must re-tighten the eBush nut.**



**6-7** One division of the eBush changes the joint glue line by 0.002" [0.05mm]. A perfect fit will be established with one or two test cuts.



*3/8" Box Joint*



*Through  
Dovetails  
Bits 80-500  
and 160*



*Half-Blind  
Dovetails  
128-500 bit*

**6-8** As shown in the examples above, each chapter provides a place to mark your perfect eBush setting, for easy repeatability the next time. ■

RTJ400 OPERATION

# CHAPTER 7 Through Dovetails

**IMPORTANT SAFETY NOTE**

Before using your Leigh RTJ400 you must have completed the preparatory steps listed in the previous pages, including reading the jig safety recommendations in Chapter 3.

**Note:** The RTJ400 can rout Full Pitch and Half Pitch Through Dovetails (see Chapter 8 for Half Pitch Through Dovetails). Instructions for routing Through Dovetails on thinner boards are identical with the exception of depths of cut and template positions for frame pins. Optional Leigh bits can be used with these instructions. See Step 7-2 below and pages 3 to 6 for complete details of optional items, router table requirements and the RTJ400 Accessory Kit.

## 7-1 Getting Started

Review this drawing and joinery terms to get a clear understanding of how the boards fit together.

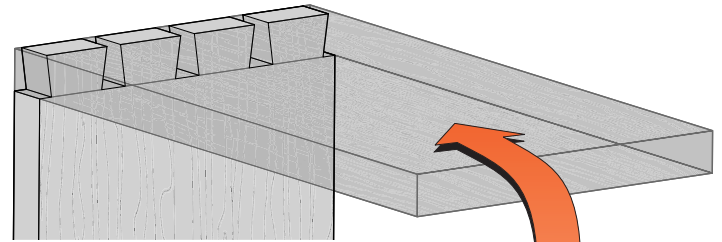
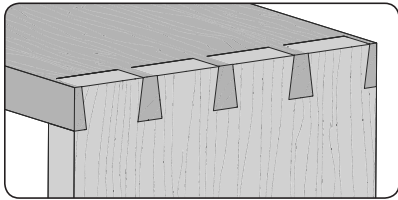

- (A) Pins
- (B) Pin sockets
- (C) Half-pins
- (D) Half-pin sockets
- (E) Tails
- (F) Tail sockets

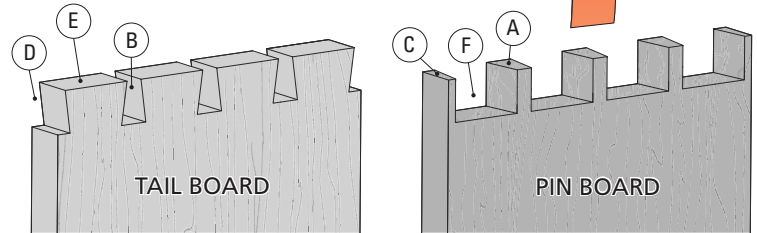

## 7-2 Bits, Guide Bushing, Collet Reducer and Blockers

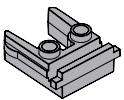

Blockers

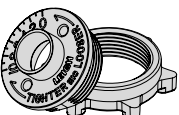

e10 Guide bushing (eBush)



Collet reducer, 172-8 for 8mm bits (Optional)

Through dovetail *tails* are routed using the included e10 guide bushing, blockers and the 80-500 through dovetail bit, or one of four optional 8mm through dovetail bits. **Note:** 8mm bits must be used with an 8mm collet or 172-8 (1/2" to 8mm) collet reducer. Through dovetail *pins* are routed with the included 160 1/2" straight bit. The 8mm dovetail bits and 172-8 are available individually or in the RTJ400 Accessory Kit (ACRTJ) at leighjigs.com. See bit specs on page 4.

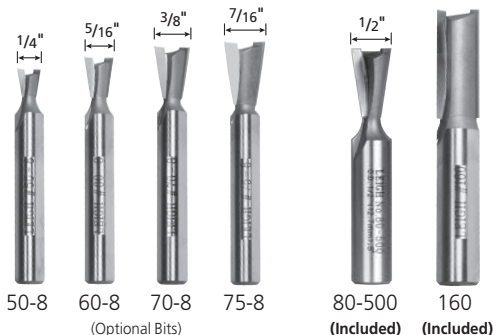

THROUGH DOVETAIL BIT CUTTING DEPTH						
All through dovetail bits have 8° angles. All carbide bit heights are slightly greater than maximum depth of cut listed.						
Bit No.	50-8	60-8	70-8	75-8	80-500	160
1/8"	[Diagram showing depth of cut for 1/8"]					
1/4"	[Diagram showing depth of cut for 1/4"]					
3/8"	[Diagram showing depth of cut for 3/8"]					
1/2"	[Diagram showing depth of cut for 1/2"]					
5/8"	[Diagram showing depth of cut for 5/8"]					
3/4"	[Diagram showing depth of cut for 3/4"]					
7/8"	[Diagram showing depth of cut for 7/8"]					
1"	[Diagram showing depth of cut for 1"]					

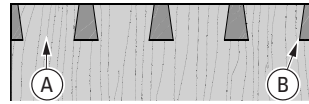

Board widths are based on the number of full tails (A) in your design. Board edges should almost always end in a half-pin (B).

Board Width Selection for Through Dovetails											
No. of Tails	1	2	3	4	5	6	7	8	9	10	
Inches	Min	1 7/16"	3"	4 9/16"	6 1/8"	7 11/16"	9 1/4"	10 13/16"	12 3/8"	13 15/16"	15 1/2"
	Exact	1 9/16"	3 1/8"	4 11/16"	6 1/4"	7 13/16"	9 3/8"	10 15/16"	12 1/2"	14 1/16"	15 5/8"
	Max	1 15/16"	3 1/2"	5 1/16"	6 5/8"	8 3/16"	9 3/4"	11 5/16"	12 7/8"	14 7/16"	16"
Millimeters	Min	37	76	116	156	196	235	275	315	355	394
	Exact	40	80	119	159	199	239	278	318	358	398
	Max	49	89	129	169	208	248	288	328	367	407

**7-3** Use this chart to determine the board width for your project. Through Dovetail joints may be routed in boards up to 1 3/16" thick for pin boards and 1" thick for tail boards. Board widths are determined by the total number of full tails in the joint design. **Note: Board widths may be wider than the chart width by half of the dovetail bit diameter or less than the chart width by one quarter of the dovetail bit diameter.**

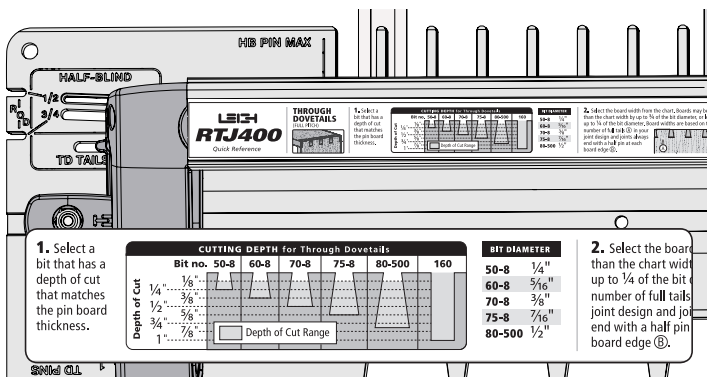

**7-4** Use the Quick Reference strip to determine the correct dovetail bit and guide bushing combination for the board thickness, in this case, the Leigh e10 Guide Bushing and the Leigh 80-500 bit.

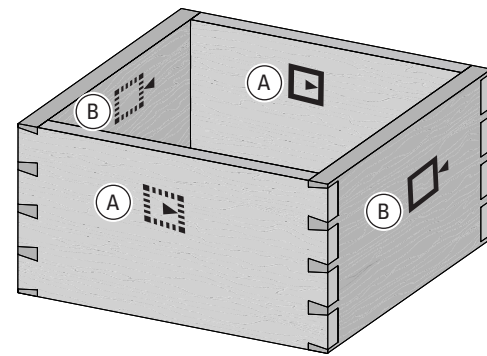

**7-5 Making a Box** Note the symbols indicating the inside or outside of the pin and tail boards. When assembled with the finished pieces properly oriented, any one of the pin ends will fit any one of the tail ends. **Mark the inside faces of the tail boards (A) and outside faces of the pin boards (B).**

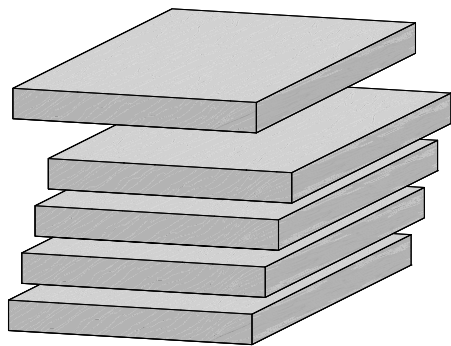

**7-6** Use five similar boards (one for testing) about 3/4" x 6 1/4" by about 12" long [19mm x 159mm x 305mm]. Boards of different thicknesses may also be joined.

**⚠ IMPORTANT: Read this whole chapter before routing any boards.**

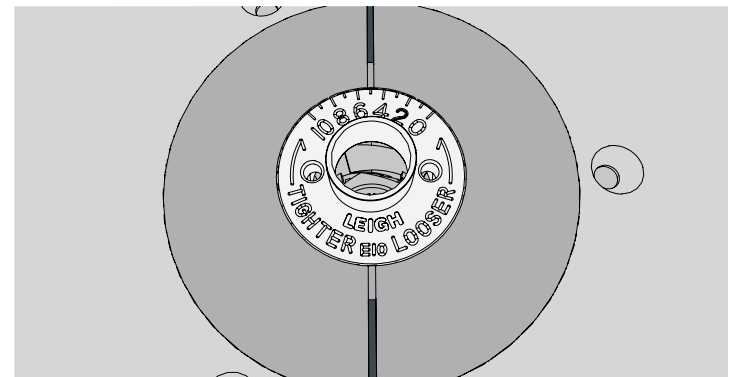

**7-7** Fit the e10 eBush to the router table insert ring. Set the eBush to 5.



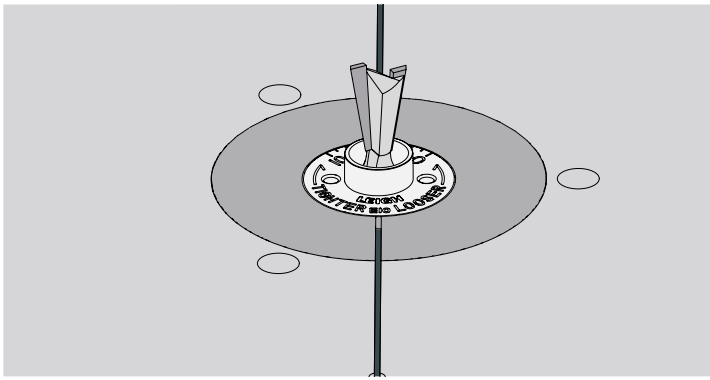

**7-8** With the router unplugged, install the Leigh 80-500 dovetail bit. ⚠ Make sure the bit spins freely within the bushing before reconnecting the power.

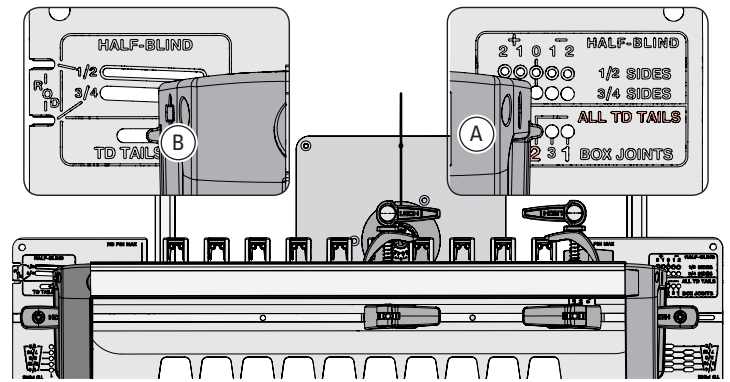

**7-9** Insert the right frame pin in **hole no.2** of the **ALL TD TAILS** mode (A) and the left frame pin in the **TD TAILS & BJ slot** (B). Securely latch the frame. ⚠ **Always latch the frame to the template after repositioning it.**

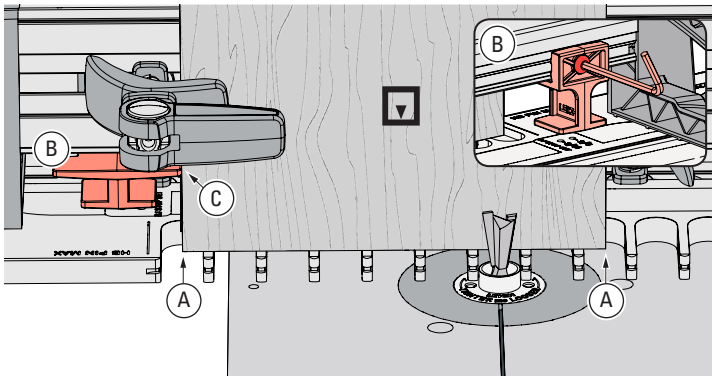

**7-10** Center tail board 1 (A) over the template with the marked inside face showing out, bottom end flush on the template, and clamp. From the other side of the frame, slide the side stop (B) to touch the tail board (C) and tighten with the hex driver.

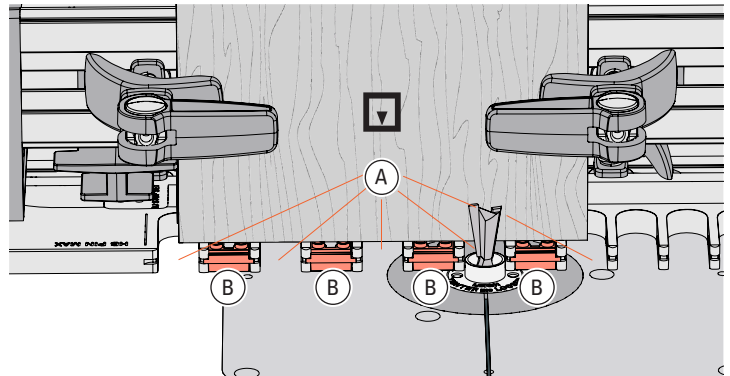

**7-11** You will be routing into the first and every alternate template opening (A). To prevent routing in the wrong opening, fit a supplied blocker (B) into the second and every alternate opening.

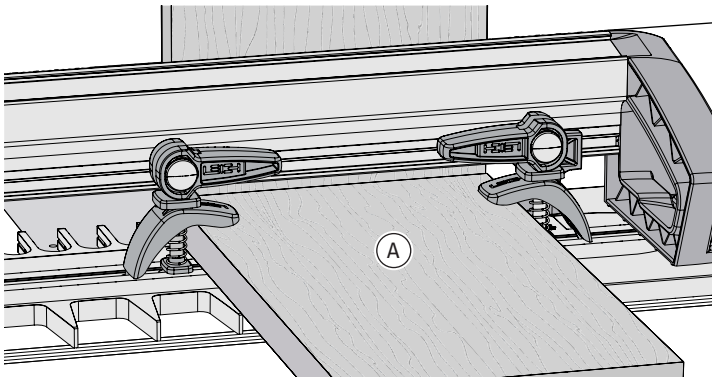

**7-12** Clamp a short scrap backer board (A) horizontally against the tail board to help prevent tear out and direct chips and dust away. This can stay in place for routing of all consecutive tail boards. The scrap board should be at least as thick as the cutting depth of the bit in Step 7-14.

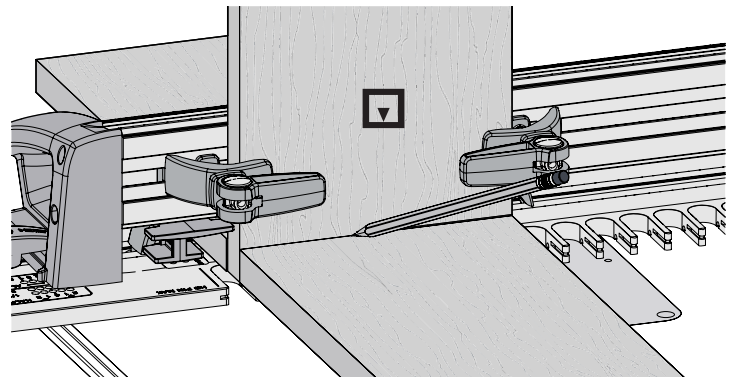

**7-13** Bit height is set using the pin board as a gauge. Place the face of the pin board on the template and pencil a line on the tail board.

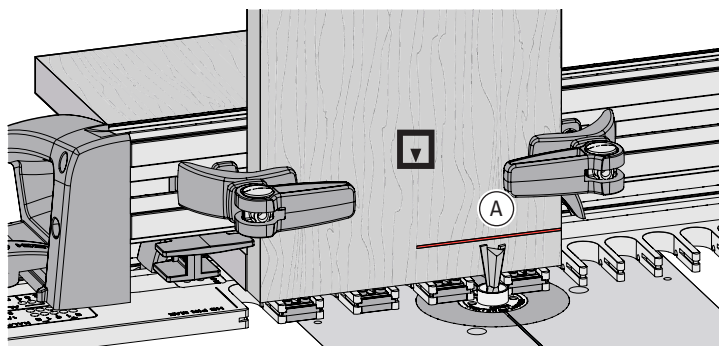

**7-14** Position the jig and tail board close to the bit and adjust the bit height to the center of the line **A**. **⚠** Double check that the bit still rotates freely. **IMPORTANT: Bit height determines the flushness of the joint, so set your bit properly the first time.** Adjustments for flushness are near the end of the chapter.

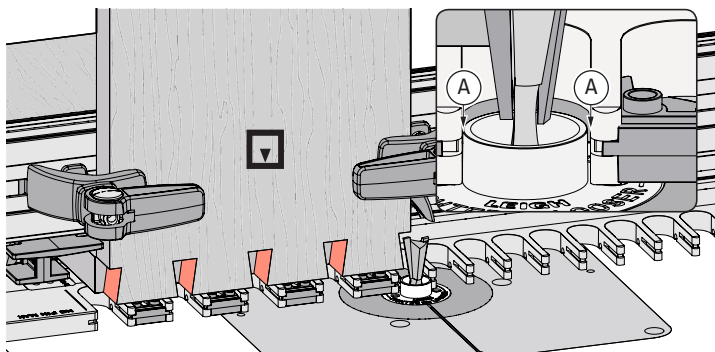

**7-15** Rout in the first and every other opening, 1, 3, 5 and 7. The eBush when set at 5 is slightly narrower than the opening **A**. **⚠** The eBush must touch one side of the opening as you enter and the other side as you exit. Do not twist the jig on the table. Keep the edge of the template square to the center line on the table.

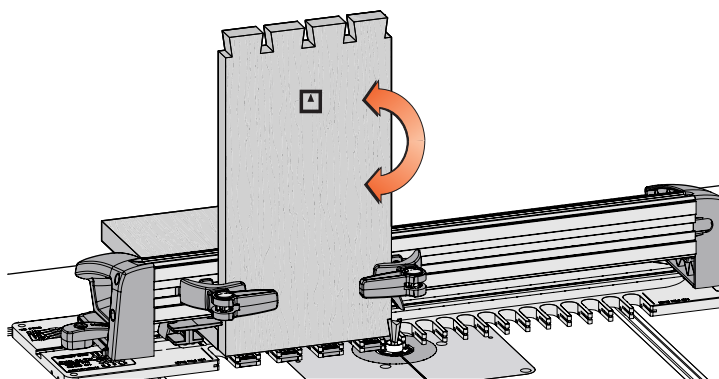

**7-16** **⚠** Be sure the router bit has stopped moving before unclamping the tail board. Rotate tail board 1 keeping the same face of the board against the jig. Rout the tails. Repeat 7-15 and 7-16 for tail board 2. Remove the tail board and backer board. **Disconnect the power and remove the 80-500 dovetail bit.**

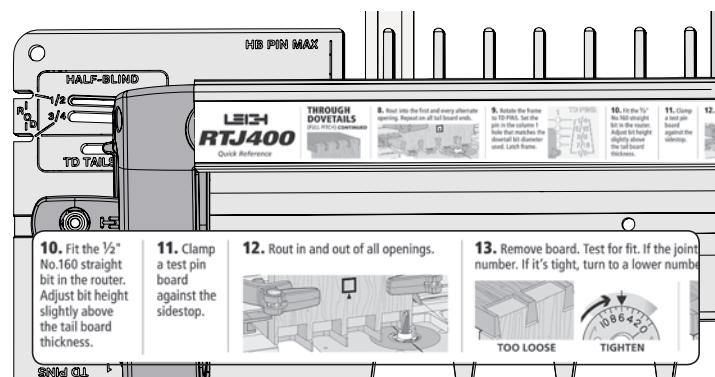

**7-17** As instructed in the Quick Reference strip, always use the 1/2" [12.7mm] Leigh 160 straight bit or equivalent spiral bit to rout the full pitch through dovetail pins.

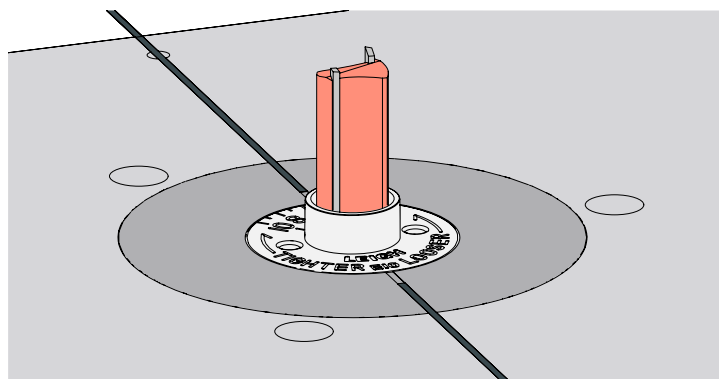

**7-18** With the router unplugged, fit the 160 straight bit to the router and leave the e10 eBush set to 5. **⚠** Be sure the bit spins freely within the guide bushing before reconnecting the power.

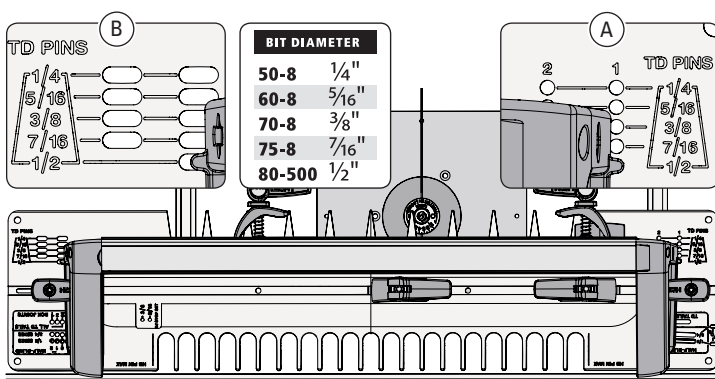

**7-19** Rotate the frame to the **TD PINS** mode. Insert the right frame pin in the **Column 1 hole** that matches the dovetail bit diameter just used to rout the tails, 1/2" in this example **A**, and the left frame pin in the matching slot **B**. Latch the frame.

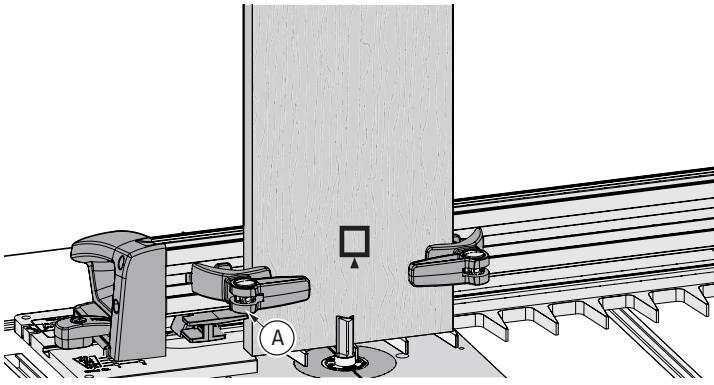

**7-20** Clamp the **test** pin board in the jig with its edge against the side stop **A** with the marked outside face out and the bottom end edge flush on the template. **Note: The side stop was set when routing the tails, so no adjustment is needed.**

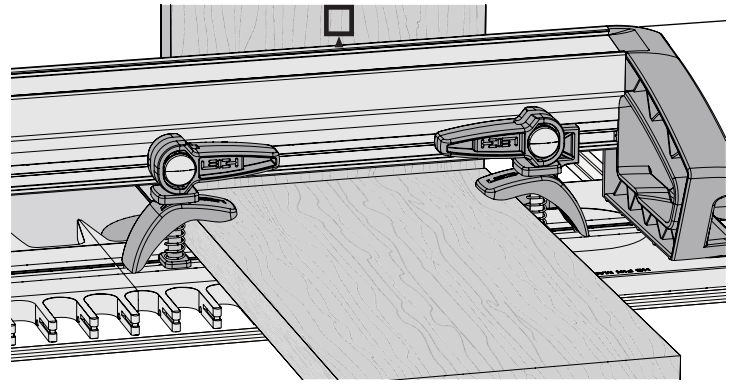

**7-21** Clamp the other end of the scrap backer board horizontally against the back of the pin board.

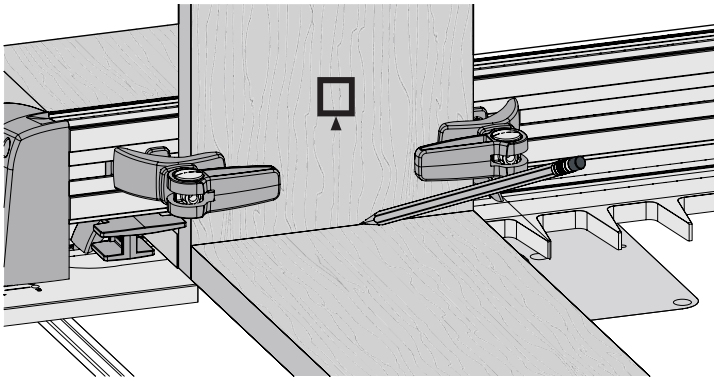

**7-22** Place the edge of the tail board on the template and pencil a line on the pin board.

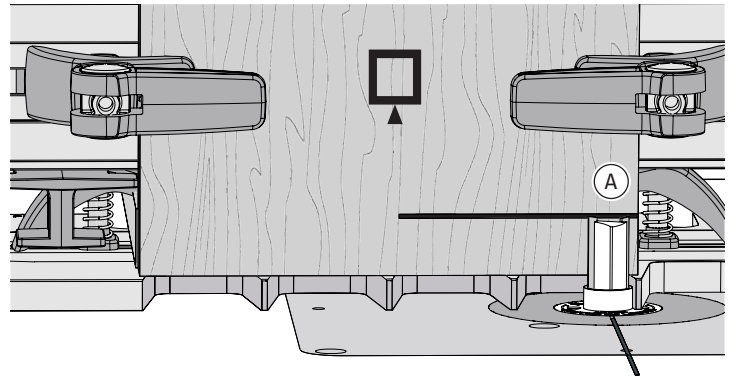

**7-23** Position the jig close to the bit and adjust the bit height until the bit tip is touching the center of the line **A**. **⚠** Double check that the bit still rotates freely. **IMPORTANT: Bit height determines the flushness of the joint, so set your bit properly the first time.** Adjustments for flushness are near the end of the chapter.

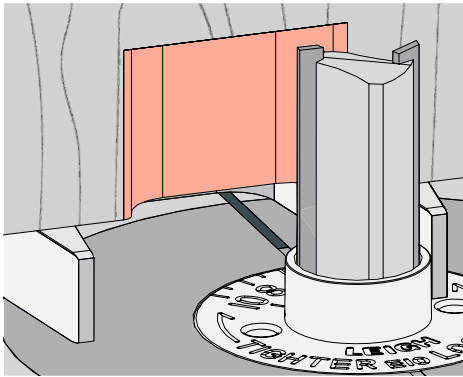

**7-24** Always rout a light climb cut between the template fingers to leave a nice clean shoulder. **⚠** **A climb cut may pull the jig to the right so be sure to control the jig firmly at all times.**

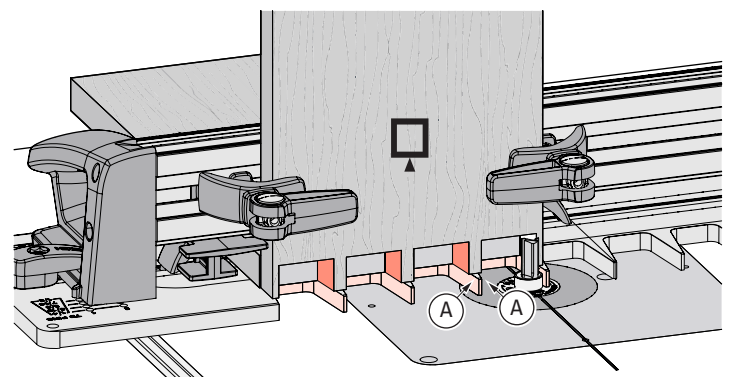

**7-25** Rout out all spaces between the template fingers, being sure the guide bushing touches each side of each finger **A** and all waste is routed between the pins.

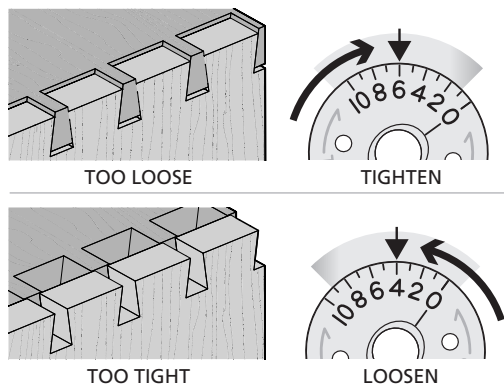

**7-26 Test for Fit** If the joint is too loose, turn the eBush to a higher number with the pin wrench, as shown in the next step. If too tight, turn the eBush to a lower number. Each increment on the eBush changes the joint glue line fit by 0.002" [0.05mm]. Half an increment, a mere 1000th inch!

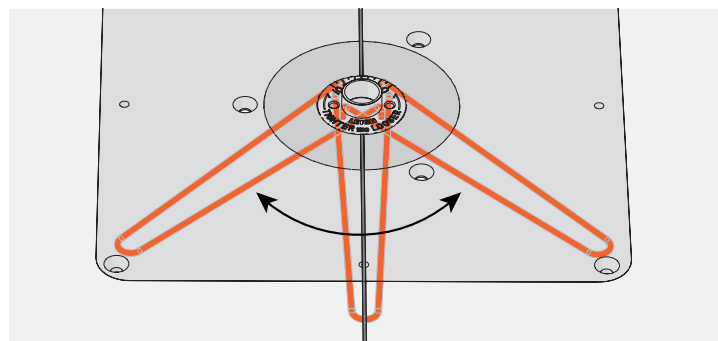

**7-27 Re-tighten the eBush nut after each guide bushing adjustment.** Rout the other end of the test pin board. Once the fit is correct, add the two eBush settings together and divide by two. **Example:** 5 for tails, 3 for pins.  $(5 + 3 = 8 \div 2 = 4)$ . Record setting "4" on an eBush diagram in the next step. Do not use this new setting for routing this test box, use **only** for future projects.

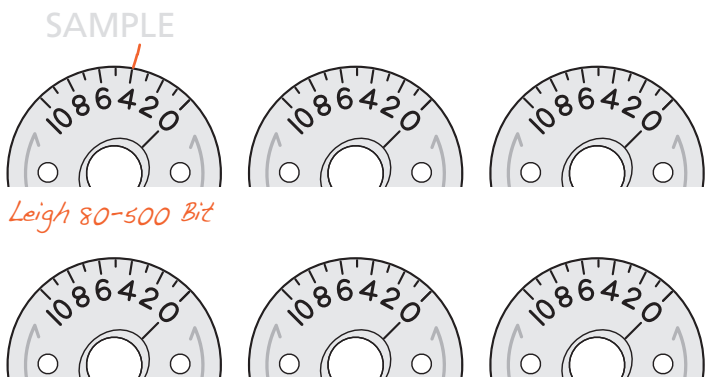

**7-28** On the eBushes above, record the settings you used to achieve perfect joint fit. The first eBush is an example of how to record your setting.

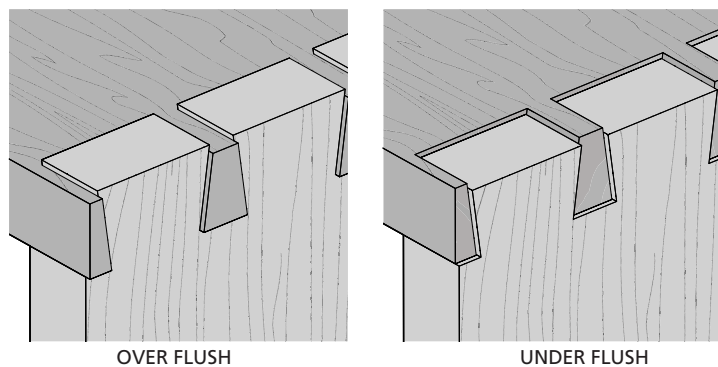

**7-29 Flushness** If the joint is over flush, lower the bit. If the joint is under flush, raise the bit.

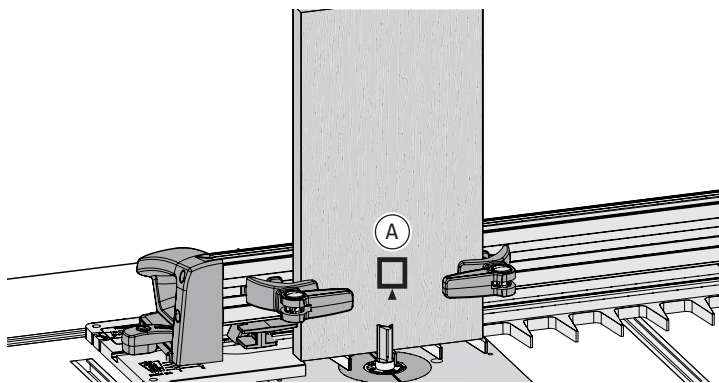

**7-30** Utilizing the final fit setting you determined in Step 7-26 (not the calculated setting in Step 7-27), the two pin boards are now ready for routing. Clamp pin board 1 to the frame against the same side stop with the marked outside face out (A) and the bottom end edge flush on the template. Rout the pins.

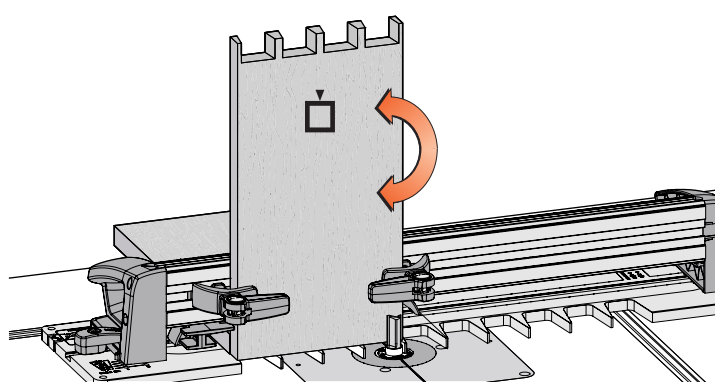

**7-31** Rotate pin board 1, keeping the marked face of the board facing out. Rout the pins. Repeat for pin board 2. All four boards are now complete and ready for assembly. ■

**RTJ400 OPERATION**

# CHAPTER 8

## Half Pitch Through Dovetails

**Note:** Optional Leigh bits and the e7 guide bushing are required in order to make half pitch through dovetails. See Step 8-2 below and pages 3 to 6 for complete details of optional items, router table requirements and the RTJ400 Accessory Kit.

**IMPORTANT SAFETY NOTE**  
 Before using your Leigh RTJ400 you must have completed the preparatory steps listed in the previous pages, including reading the jig safety recommendations in Chapter 3.

### 8-1 Getting Started

Review this drawing and joinery terms to get a clear understanding of how the boards fit together.

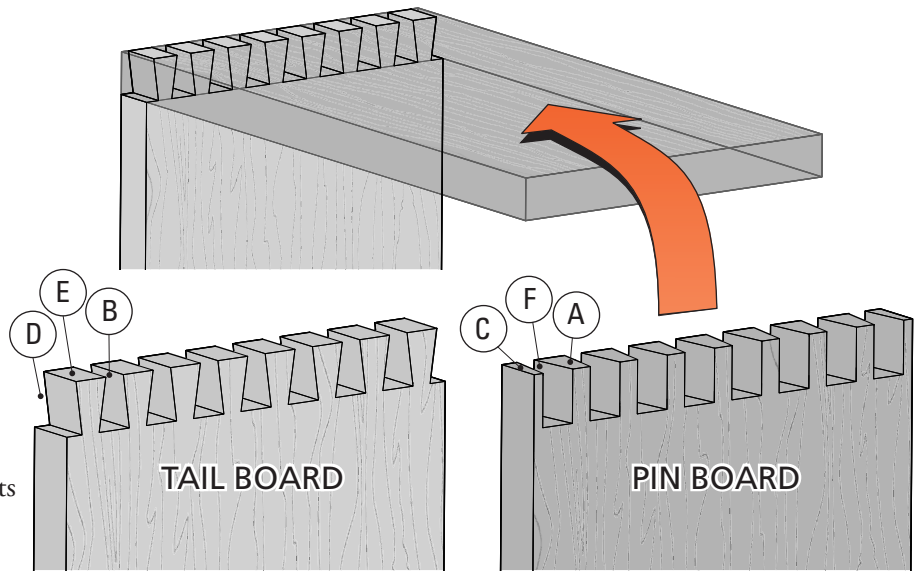
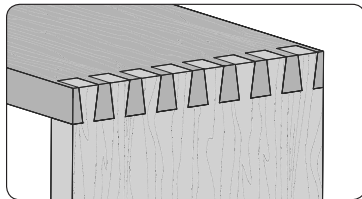

- (A) Pins
- (B) Pin sockets
- (C) Half-pins
- (D) Half-pin sockets
- (E) Tails
- (F) Tail sockets

### 8-2 Bits, Guide Bushings and Collet Reducer



Half pitch through dovetail *tails* are routed using the included e10 guide bushing and one of four optional 8mm through dovetail bits. **Note:** 8mm bits must be used with a 8mm collet or 172-8 (1/2" to 8mm) collet reducer. Half pitch through dovetail *pins* are routed with the optional e7 guide bushing and 140-8 or equivalent straight bit. The e7, all five bits and the 172-8 are available individually or in the RTJ400 Accessory Kit (ACRT) at leighjigs.com. See bit specs on page 4.

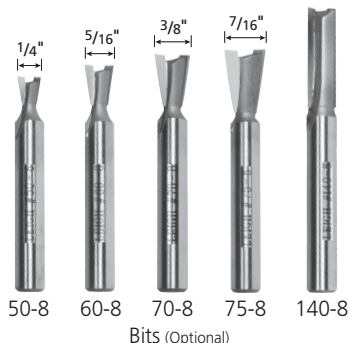
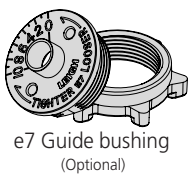

HALF PITCH THROUGH DOVETAIL BIT CUTTING DEPTH					
<small>All through dovetail bits have 8° angles. All carbide bit heights are slightly greater than maximum depth of cut listed.</small>					
Bit No.	50-8	60-8	70-8	75-8	140-8
Depth of Cut	Denotes Depth of Cut Range				
1/4"	[Range]				
3/8"	[Range]				
1/2"	[Range]				
5/8"	[Range]				
3/4"	[Range]				
7/8"	[Range]				
1"	[Range]				

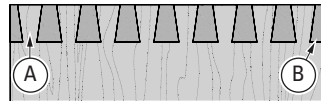

Board widths are based on the number of full tails **A** in your design. Board edges should always end in a half-pin **B**.

**Board Width Selection for Half Pitch Through Dovetails**

No. of Tails	1	2	3	4	5	6	7	8	9	10	11	12	13	14	15	16	17	18	19	20	
Inches	Min	2 <sup>3</sup> / <sub>32</sub> "	1 1/2"	2 <sup>9</sup> / <sub>32</sub> "	3 1/16"	3 <sup>27</sup> / <sub>32</sub> "	4 3/8"	5 <sup>13</sup> / <sub>32</sub> "	6 3/16"	6 <sup>31</sup> / <sub>32</sub> "	7 3/4"	8 <sup>17</sup> / <sub>32</sub> "	9 5/16"	10 3/32"	10 7/8"	11 21/32"	12 7/16"	13 7/32"	14"	14 <sup>29</sup> / <sub>32</sub> "	15 9/16"
	Exact	2 <sup>5</sup> / <sub>32</sub> "	1 9/16"	2 11/32"	3 1/8"	3 <sup>29</sup> / <sub>32</sub> "	4 11/16"	5 15/32"	6 1/4"	7 1/32"	7 13/16"	8 19/32"	9 3/8"	10 5/32"	10 15/16"	11 23/32"	12 1/2"	13 9/32"	14 1/16"	14 <sup>27</sup> / <sub>32</sub> "	15 5/8"
	Max	2 <sup>9</sup> / <sub>32</sub> "	1 11/16"	2 15/32"	3 1/4"	4 1/32"	4 13/16"	5 19/32"	6 3/8"	7 5/32"	7 15/16"	8 23/32"	9 1/2"	10 3/32"	11 1/16"	11 27/32"	12 5/8"	13 13/32"	14 3/16"	14 <sup>31</sup> / <sub>32</sub> "	15 3/4"
Millimeters	Min	18	38	58	77	97	117	137	156	176	196	216	235	255	275	295	314	334	354	374	393
	Exact	20	40	59	79	99	119	138	158	178	198	217	237	257	277	296	316	336	356	375	395
	Max	23	43	62	82	102	122	141	161	181	201	220	240	260	280	299	319	339	359	378	398

**8-3** Use this chart to determine the board width for your project. Through Dovetail joints may be routed in boards up to 5/8" thick for pin boards and 1" thick for tail boards. Board widths are determined by the total number of full tails in the joint design. **Note: Board widths may be wider than the chart width by half of the dovetail bit diameter or less than the chart width by one quarter of the dovetail bit diameter.**

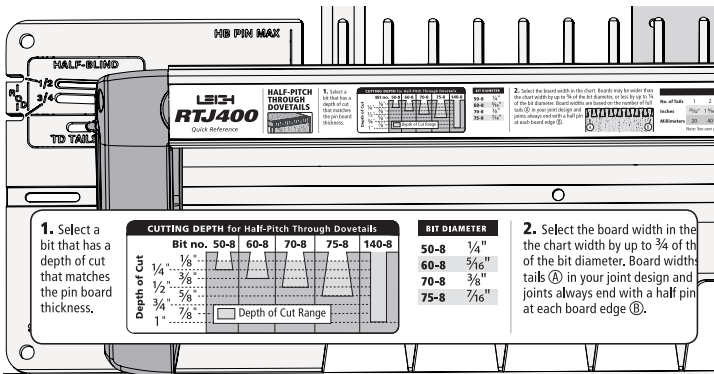

**8-4** Use the Quick Reference strip to determine the correct dovetail bit and guide bushing combination for the board thickness, in this case, the Leigh e10 guide bushing and the optional 3/8" Leigh 70-8 dovetail bit for tails and the optional e7 guide bushing and Leigh 140-8 straight bit for pins.

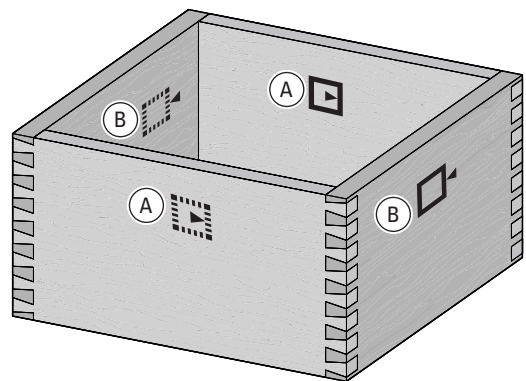

**8-5 Making a Box** Note the symbols indicating the inside or outside of the pin and tail boards. When assembled with the finished pieces properly oriented, any one of the pin ends will fit any one of the tail ends. **Mark the inside faces of the tail boards A and outside face of the pin boards B.**

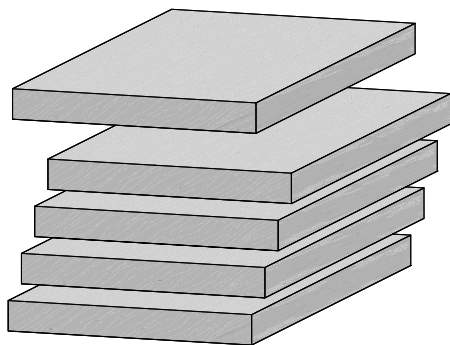

**8-6** Prepare five similar boards (one for testing) about 1/2" x 6 1/4" by about 12" long [13mm x 159mm x 305mm]. Boards of different thicknesses may also be joined.

**IMPORTANT:** Read this whole chapter before routing any boards.

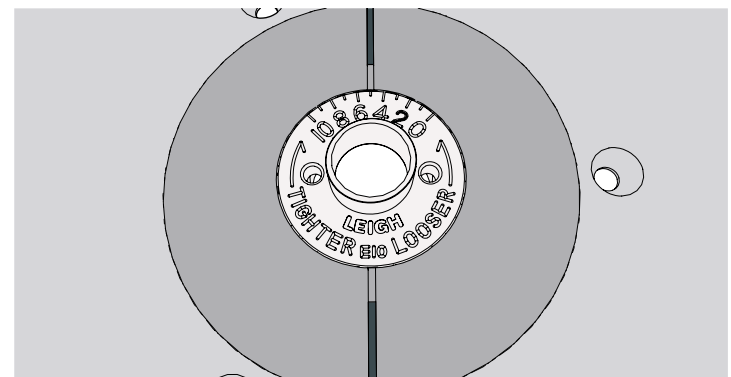

**8-7** Fit the e10 eBush to the router table insert ring, set to 5.

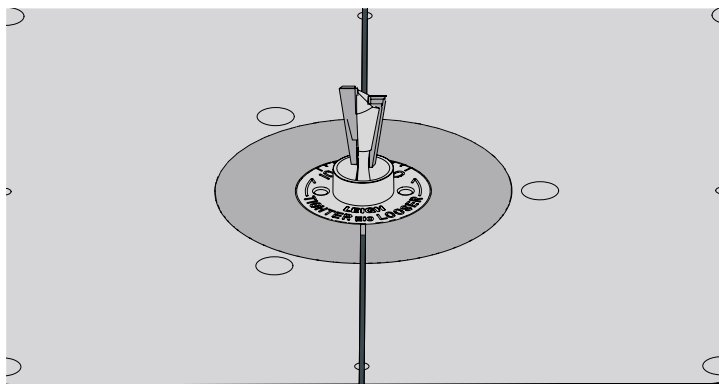

**8-8** With the router unplugged, install the Leigh 70-8 dovetail bit. ⚠ Make sure the bit spins freely within the guide bushing before reconnecting the power.

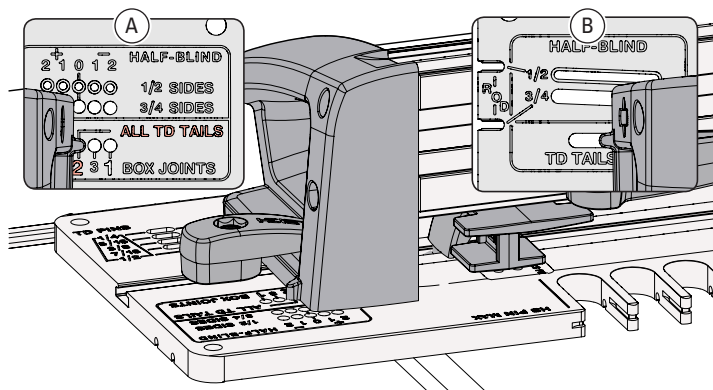

**8-9** Insert the right frame pin in the **No.2 hole** of **ALL TD TAILS** mode (A) and the left frame pin in the corresponding **TD TAILS & BJ slot** (B). Securely latch the frame.

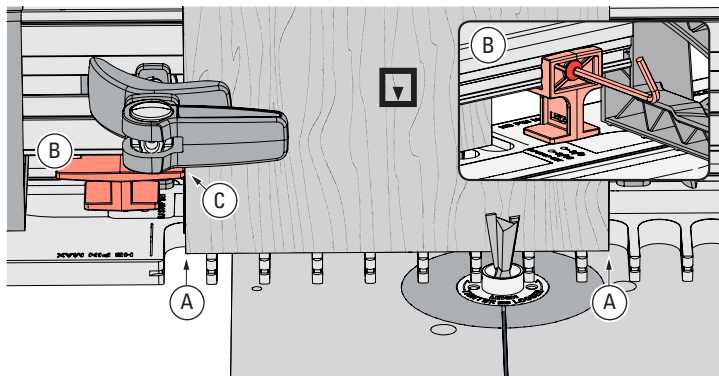

**8-10** Center tail board 1 (A) over the template with the marked inside face showing out, bottom end flush on the template, and clamp. From the other side of the frame, slide the side stop (B) to touch the tail board (C) and tighten with the hex driver.

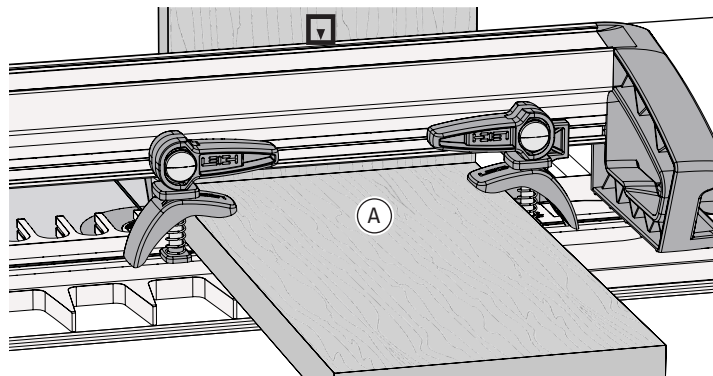

**8-11** Clamp a short scrap backer board (A) horizontally against the tail board to help prevent tear out and direct chips and dust away. This can stay in place for routing of all consecutive tail boards. The scrap board should be at least as thick as the cutting depth of the bit in Step 8-13.

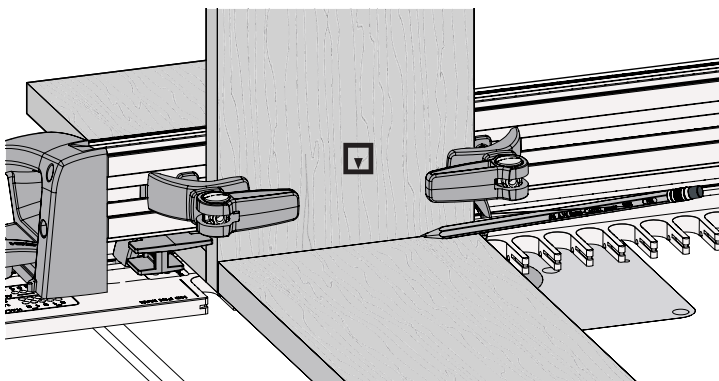

**8-12** Place the edge of a pin board on the template and pencil a line on the tail board.

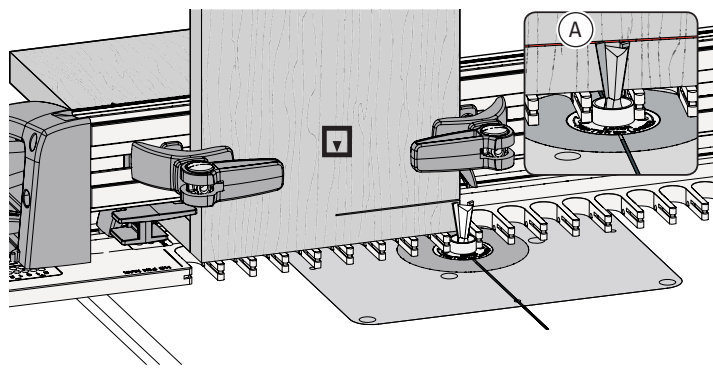

**8-13** Position the jig close to the dovetail bit and adjust the bit height until the bit tip is touching the center of the line (A). ⚠ Double check that the bit still rotates freely. **Note: Make sure you are using the e10 eBush set on 5.**

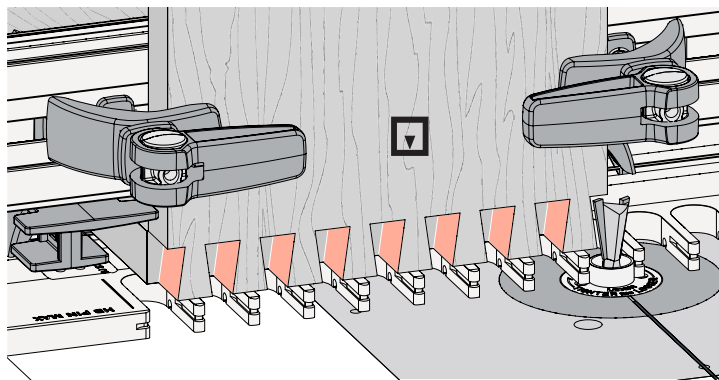

**8-14** Rout the tails in every template opening. ⚠ The eBush must touch one side of the opening as you enter and the other side as you exit. Rotate tail board 1 and rout the other end. Repeat routing for tail board 2. Remove the tail board and backer board. **Disconnect the power and remove the e10 eBush & dovetail bit.**

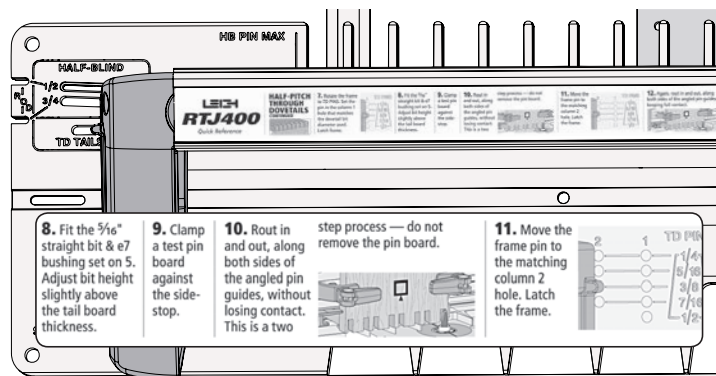

**8-15** Check the Quick Reference strips for the correct guide bushing and bit selection for half pitch pins. **Note:** Half pitch dovetails always use the optional e7 guide bushing and the optional Leigh 140-8 straight bit. For cleaner routing, use the optional 5/16" Leigh 170 (HSS) or 170C (solid carbide) spiral upcut bit.

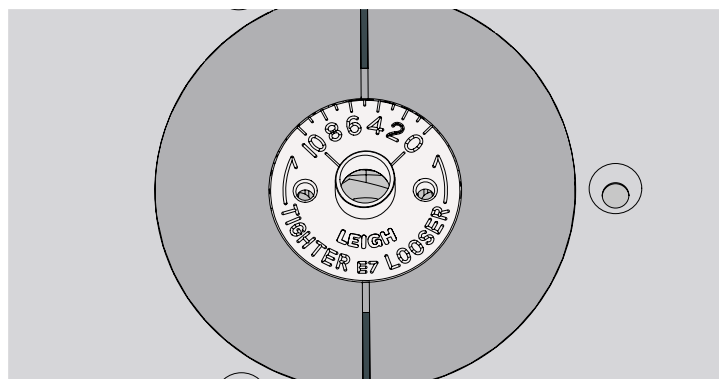

**8-16** Fit the e7 eBush to the router table/router table insert, set to 5.

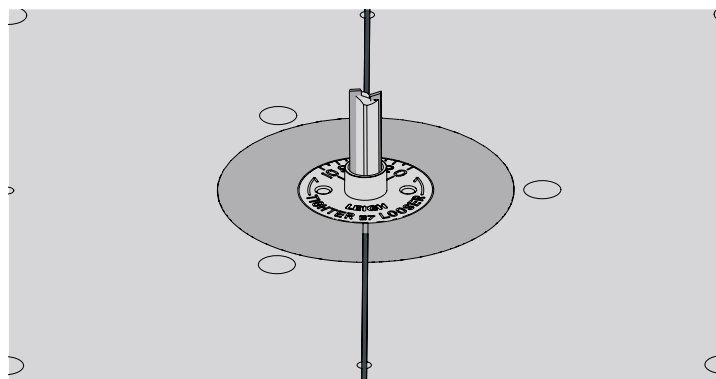

**8-17** With the router unplugged, install the 5/16" [8mm] 140-8 straight or equivalent spiral bit. ⚠ Make sure the bit spins freely within the eBush before reconnecting the power.

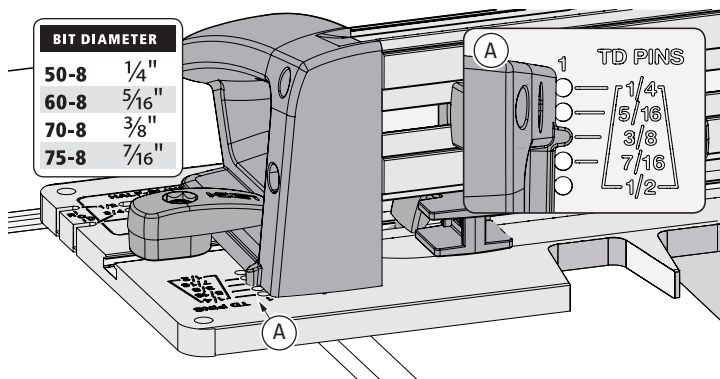

**8-18** Rotate the frame to the **TD PINS** mode. Insert the right frame pin in the **Column 1 hole** that matches the dovetail bit diameter that was used to rout the tails, 3/8" in this example (A), and the left frame pin in the matching slot. Latch the frame.

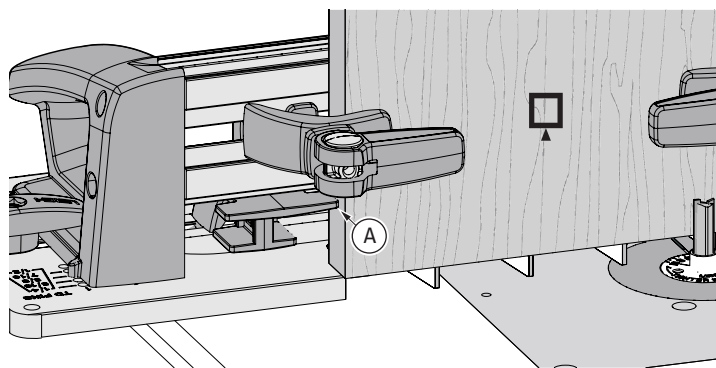

**8-19** Clamp the **test** pin board in the jig with its edge against the side stop (A) with the marked outside face out and the bottom end edge flush on the template. **Note: The side stop was set when routing the tails, so no adjustment is needed.**



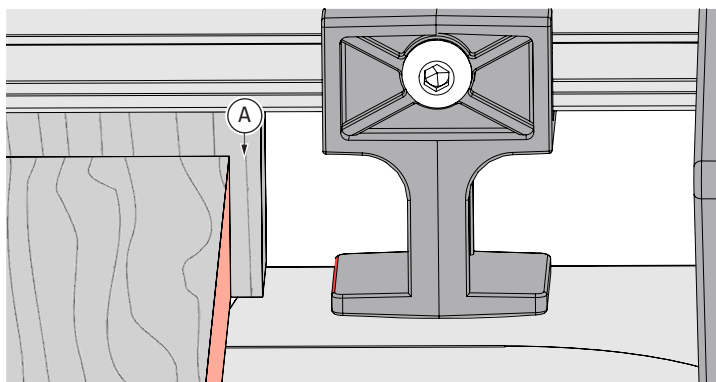

**8-20** Position a backer board 1/2" [13mm] from the board edge (A). This prevents the backer board from interfering with the side stop when the frame is repositioned in the second step. The backer board stays in place for the complete procedure. **Note: Clamps removed for clarity.**

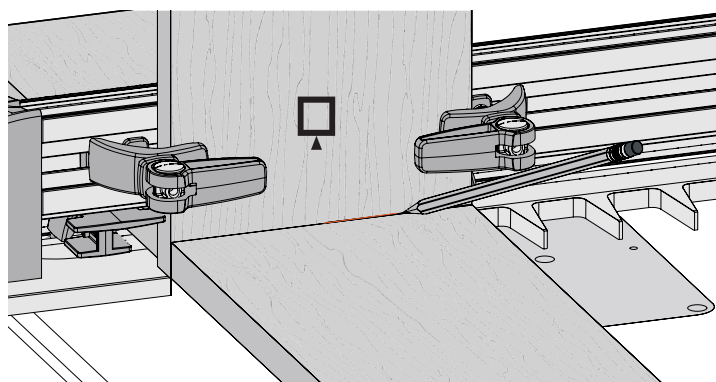

**8-21** Place the end of a tail board on the template and pencil a line on the pin board.

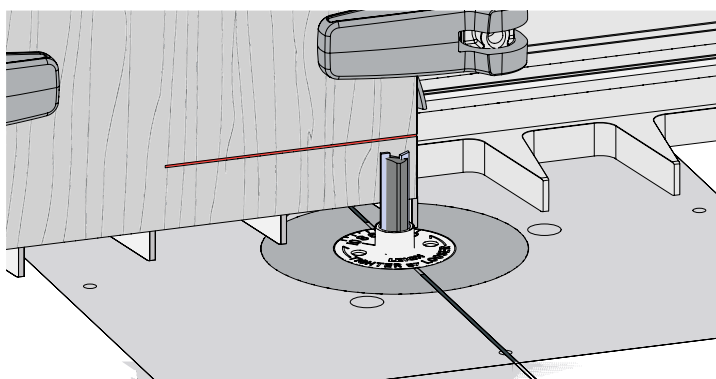

**8-22** Adjust the bit so the tip of the bit is in the center of the pencil line. ⚠ Double check that the bit still rotates freely. **IMPORTANT: Bit height determines the flushness of the joint, so set your bit properly the first time.** Adjustments for flushness are near the end of the chapter.

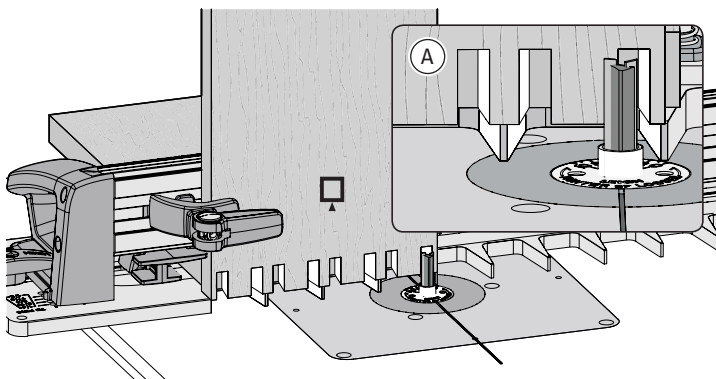

**8-23** ⚠ Very carefully, **without losing guide bushing contact with the angled finger surfaces (A)**, rout in and out, both sides of the angled fingers. **This a two step process – DO NOT remove the pin board or backer board.**

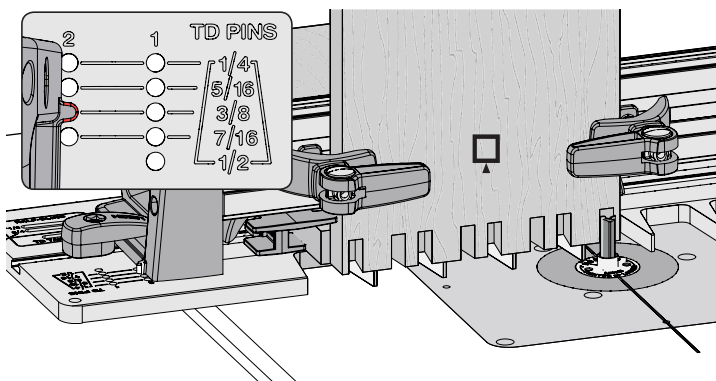

**8-24** Move the frame pin to the **Column 2 hole** of the **3/8" TD PINS** mode. (A) Latch the frame.

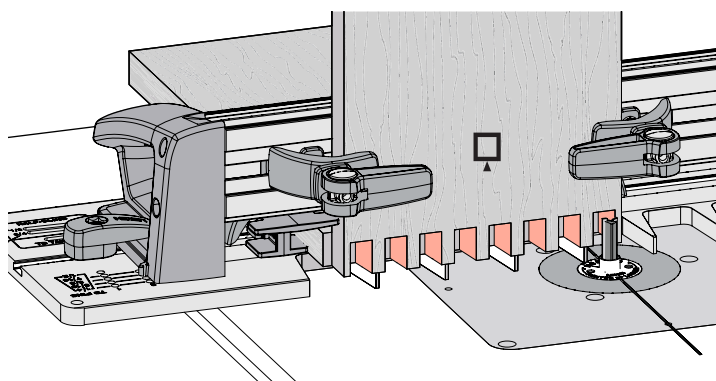

**8-25** Again, very carefully rout in and around both sides of the angled pin guides, **without losing guide bushing contact with the surface of the angled template fingers.**

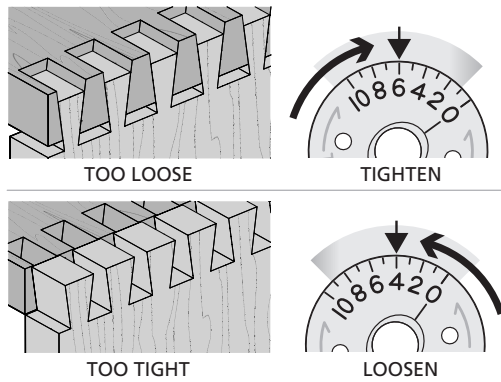

**8-26 Test for Fit** If the joint is too loose, turn the eBush to a higher number with the pin wrench as shown in the next step. If the joint is too tight, turn the eBush to a lower number. Each increment on the eBush changes the joint glue line fit by 0.002" [0.05mm]. Half an increment, a mere 1000th inch!

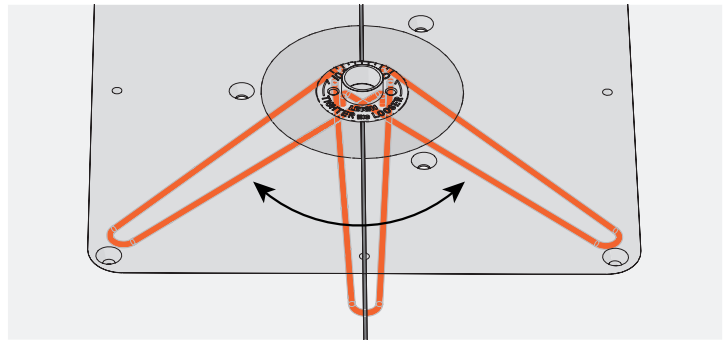

**8-27 Re-tighten the eBush nut after each guide bushing adjustment.** Rout a new pin board. Once the fit is correct, add the two eBush settings together and divide by two. **Example:** 5 for tails, 3 for pins ( $5 + 3 = 8 \div 2 = 4$ ). Record setting "4" on an eBush diagram in the next step. Do not use this new setting for routing this test box, **only** for future projects.

### SAMPLE

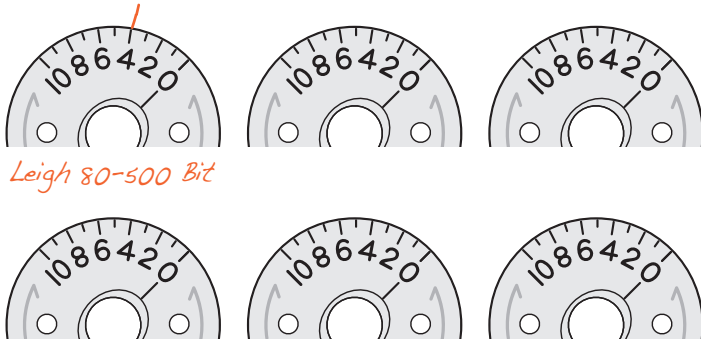

**8-28** On the eBushes above, record the settings you used to achieve perfect joint fit. The first eBush is an example of how to record your setting.

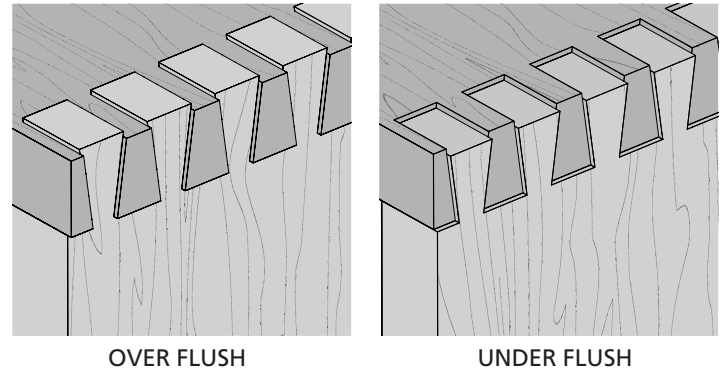

**8-29 Flushness** If the joint is over flush, lower the bit (decrease depth of cut). If the joint is under flush, raise the bit (increase depth of cut).

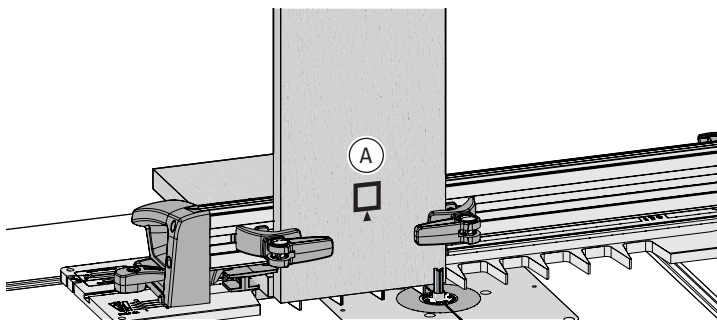

**8-30** Utilizing the final fit setting you determined from Step 8-26 (not the calculated setting in 8-27), the two pin boards are now ready for routing. Reposition the frame to column 1. Clamp pin board 1 to the frame against the side stop with the marked outside face out (A) and the bottom end edge flush on the template. Now rout the first half of the pins. Reposition the frame to column 2 and finish the pins.

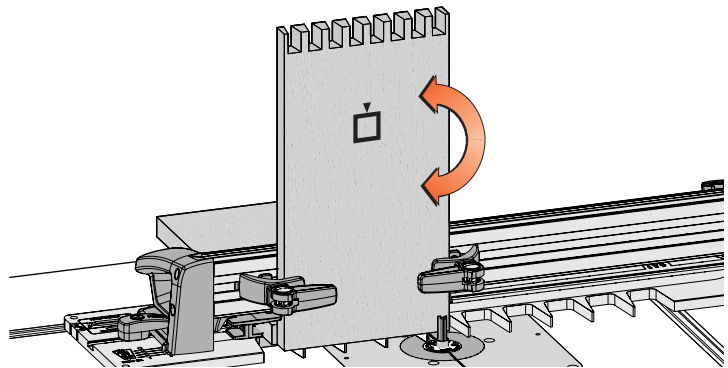

**8-31** Rotate pin board 1 and rout the other end, repeating the steps in reverse order. Repeat routing for pin board 2. All four boards are now complete and ready for assembly. ■

## RTJ400 OPERATION

## CHAPTER 9 Half-Blind Dovetails

Half-Blind Dovetails

Rabbeted Half-Blind Dovetails

**Note:** Optional half-blind dovetail bits can be used with these instructions. See Step 9-2 below and pages 3 to 6 for complete details of optional items, router table requirements and the RTJ400 Accessory kit.

### IMPORTANT SAFETY NOTE

Before using your Leigh RTJ400 you must have completed the preparatory steps listed in the previous pages, including reading the jig safety recommendations in Chapter 3.

### Half-Blind Dovetails

#### 9-1 Getting Started

Review the drawing opposite, to get a clear understanding of how the boards fit together and to learn the joinery terms.

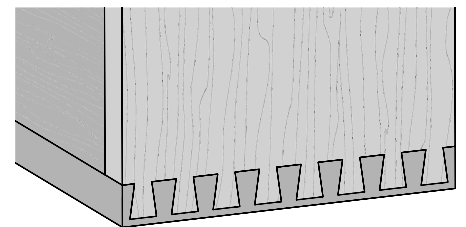
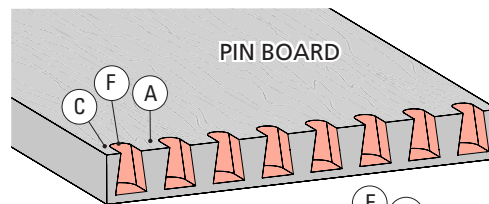
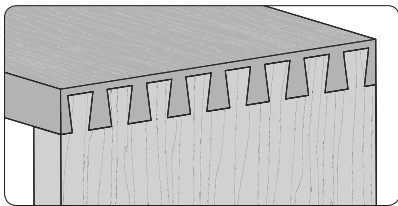

- Ⓐ Pins
- Ⓑ Pin sockets
- Ⓒ Half-pins
- Ⓓ Half-pin sockets
- Ⓔ Tails
- Ⓕ Tail sockets

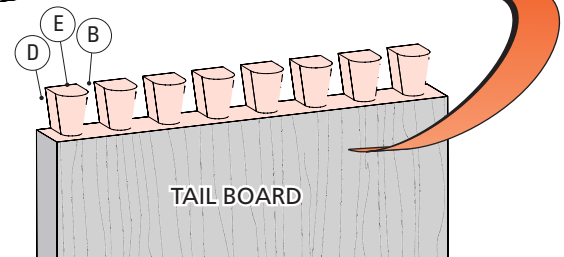

#### 9-2 Bits, Guide Bushing and Cutter Depth Gauge

All half-blind dovetail *tails* and *pins* are routed in a single pass with the included e10 guide bushing and the 120-500 half-blind dovetail bit, or two optional bits available individually or in the RTJ400 Accessory Kit (ACRTJ) at leighjigs.com. See bit specs on page 4. Each bit is designed to cut to a specific cutting depth and is set using the Leigh cutter depth gauge. The stop rod is used for routing board thicknesses of  $\frac{7}{16}$ " [11mm] to  $\frac{5}{8}$ " [16mm]. Note: Half-blind dovetail bits must be  $\frac{1}{2}$ " in diameter.

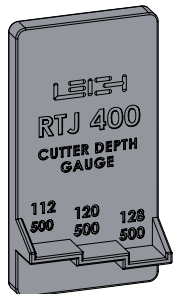

Cutter Depth Gauge



e10 Guide Bushing (eBush)



128-500 (Optional) 120-500 (Included) 112-500 (Optional)

CUTTING DEPTH for Half-Blind Dovetails			
	Bit no. 128-500	120-500	112-500
Depth	18°	14°	12°
	$\frac{3}{8}$ "	$\frac{1}{2}$ "	$\frac{19}{32}$ "

Stop rod

### 9-3 Board Width Selection

Use this chart to determine the board width for your project. Half-blind joints may be routed in boards up to 1" thick. Board widths are based on the number of full tails (A) in the joint design. Board edges always end with a half pin (B). Board widths in the chart below may be increased by 1/4" [6mm] or decreased by 1/8" [3mm] if required.

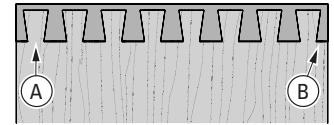

Board Width Selection for Half-Blind Dovetails																					
No. of Tails	1	2	3	4	5	6	7	8	9	10	11	12	13	14	15	16	17	18	19	20	
Inches	Min	2 1/32"	1 7/16"	2 7/32"	3"	3 25/32"	4 9/16"	5 1 1/32"	6 1/8"	6 29/32"	7 1 1/16"	8 15/32"	9 1/4"	10 1/32"	10 13/16"	11 19/32"	12 3/8"	13 5/32"	13 15/16"	14 23/32"	15 1/2"
	Exact	2 5/32"	1 1/16"	2 1 1/32"	3 1/8"	3 29/32"	4 1 1/16"	5 1 5/32"	6 1/4"	7 1/32"	7 13/16"	8 19/32"	9 3/8"	10 5/32"	10 15/16"	11 23/32"	12 1/2"	13 9/32"	14 1/16"	14 27/32"	15 5/8"
	Max	1 1/32"	1 13/16"	2 19/32"	3 3/8"	4 5/32"	4 15/16"	5 23/32"	6 1/2"	7 1 1/16"	8 1/16"	8 27/32"	9 5/8"	10 13/32"	11 1/16"	11 31/32"	12 3/4"	13 17/32"	14 3/16"	15 3/32"	15 7/8"
Millimeters	Min	17	37	56	76	96	116	136	155	175	195	215	234	254	274	294	313	333	353	373	392
	Exact	20	40	60	79	99	119	139	158	178	198	217	237	257	277	297	316	336	356	376	395
	Max	26	45	65	85	105	124	144	164	184	203	223	243	263	282	302	322	342	361	381	401

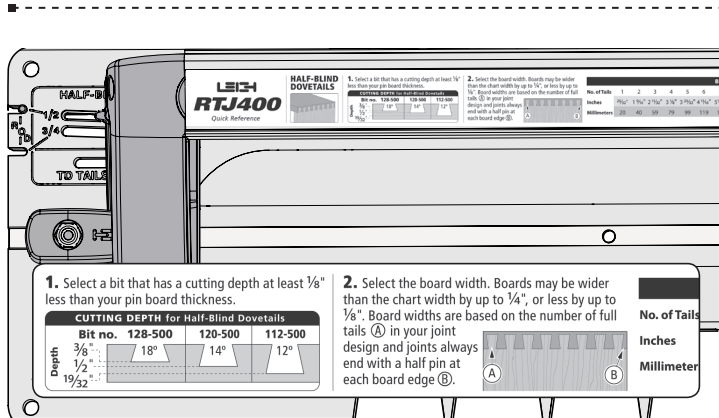

**9-4** Use the Quick Reference strip to determine the correct dovetail bit and guide bushing combination for the board thickness, in this case, the Leigh e10 Guide Bushing and the optional 1/2" 18° dovetail bit.

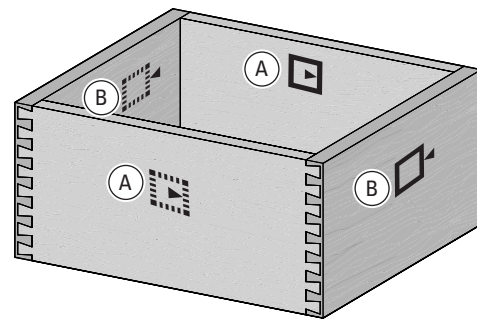

**9-5 Making a Box** Note the symbols indicating the inside or outside of the pin and tail boards. When assembled with the finished pieces properly oriented, any one of the pin ends will fit any one of the tail ends. **Mark the inside faces of the tail boards (A) and outside face of the pin boards (B).**

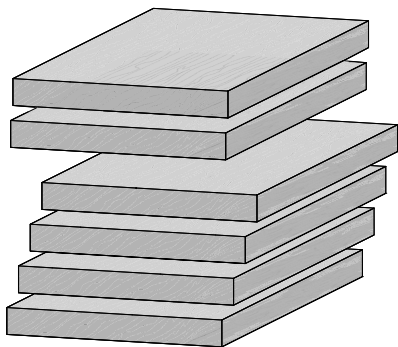

**9-6** Prepare six similar boards (two for testing) about 5/8" x 6 1/4" by about 12" long [13mm x 159mm x 305mm]. Boards of different thicknesses may also be joined. **IMPORTANT: Read this whole chapter before routing any boards.**

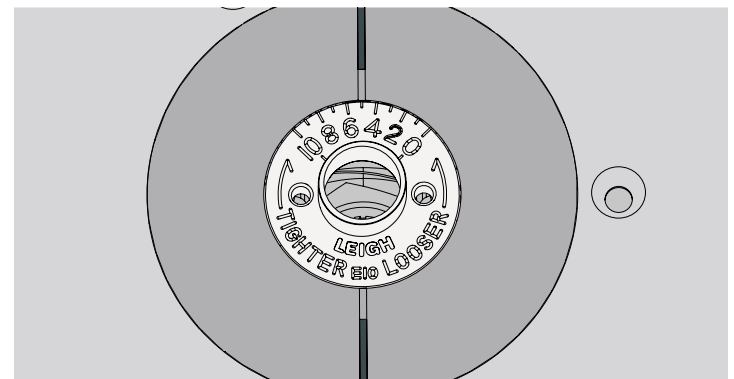

**9-7** Fit the e10 eBush to the router table insert ring, set to 5.

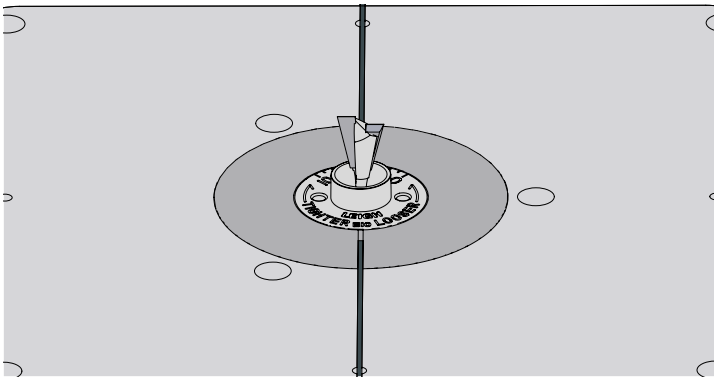

**9-8** Unplug the router and install the Leigh 120-500 dovetail bit. ⚠️ Make sure the bit spins freely before reconnecting the power.

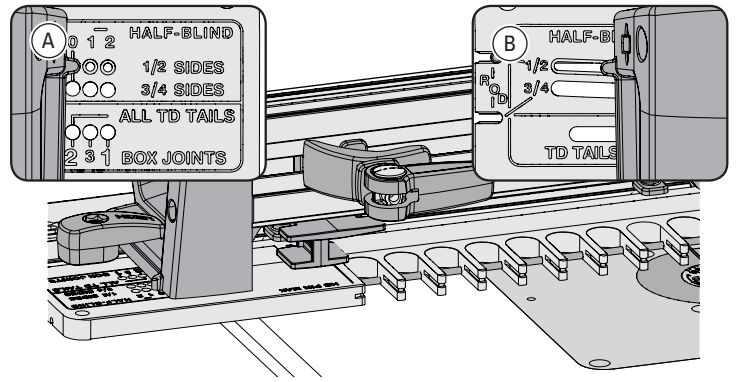

**9-9** Insert the right frame pin in the **No.0 hole** of **HALF-BLIND 1/2" SIDES** mode (A) and the left frame pin in the matching **1/2" slot** (B). Latch the frame. **Note: The HALF-BLIND pin hole settings refer only to the thickness of the tail board (drawer side).**

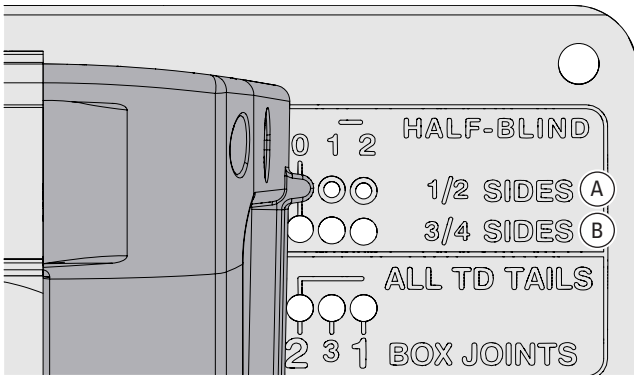

**9-10 NOTE:** Use the **1/2" SIDES** row (A) for tail boards (sides)  $\frac{3}{8}$ " [9mm] to  $\frac{5}{8}$ " [16mm] thick and the **3/4" SIDES** row (B) for tail boards  $\frac{1}{16}$ " [17.5mm] to  $\frac{7}{8}$ " [22mm] thick.

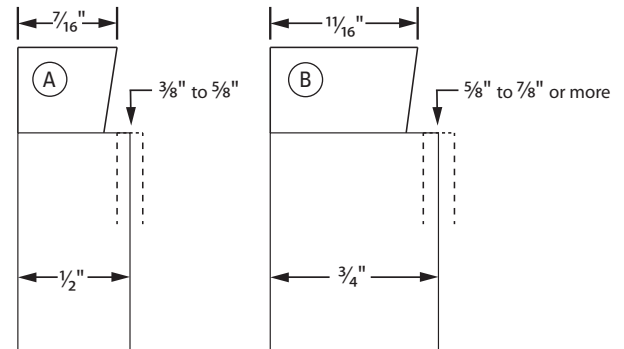

**9-11** When the frame pin and stop rod are in the  $\frac{1}{2}$ " positions, all tails will be this dimension (A), regardless of actual board thickness (dashed line). Similarly, when the frame pin and stop rod are in the  $\frac{3}{4}$ " hole, all tails will be this dimension (B), regardless of actual board thickness.

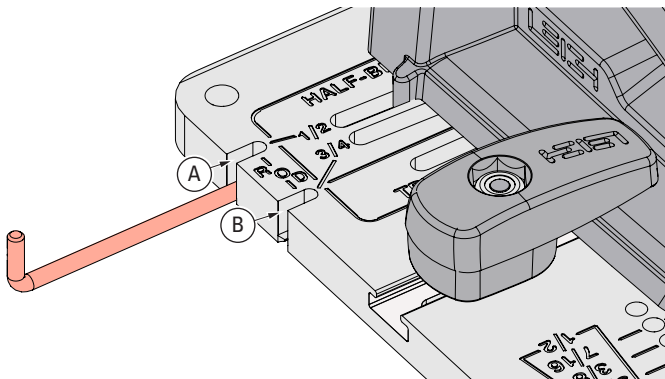

**9-12 The Stop Rod.** For tail boards (sides) from  $\frac{3}{8}$ " [9mm] to  $\frac{5}{8}$ " [16mm] thick, insert the stop rod in the  $\frac{1}{2}$ " slot (A). **Note: For tail boards  $\frac{1}{16}$ " [17.5mm] thick or greater, the stop rod is stored in the  $\frac{3}{4}$ " slot (B).**

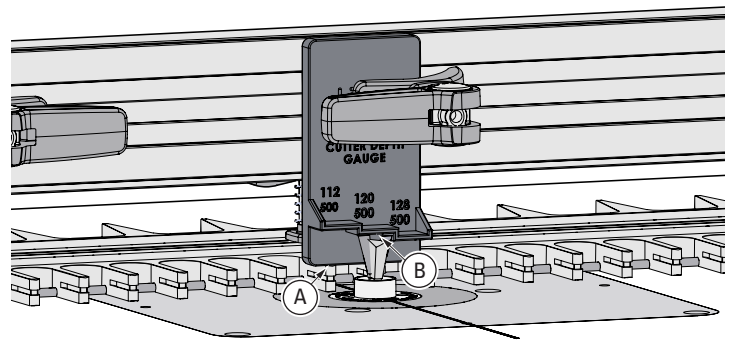

**9-13 Bit Height:** Clamp the cutter depth gauge as shown, flush on the template (A). Raise the bit until it touches the bottom of the gauge for the selected bit (B). ⚠️ Double check that the bit still rotates freely. **Hint:** As you raise the bit, slide a piece of paper back and forth until it is trapped and snags on the bit.

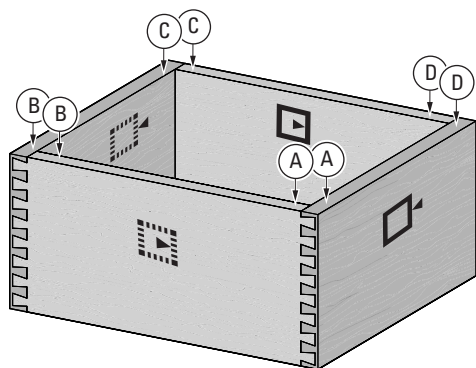

**9-14** When making a box, it is important to label the corners of each board (A), (B), (C) and (D). When routing the corners of the box, both halves of each corner must be in the jig and routed at the same time.

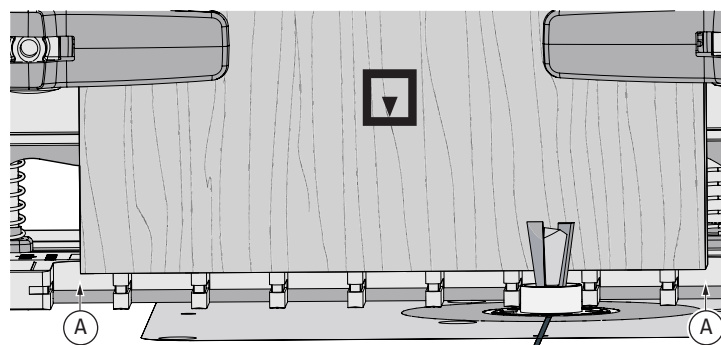

**9-15** Center a **test** tail board over the template so that the side edges (A) are equally spaced over the template fingers and the end edge sits flush on the template. The edge of the board must be positioned halfway into the first opening, otherwise you'll rout into the side stop. Clamp the tail board.

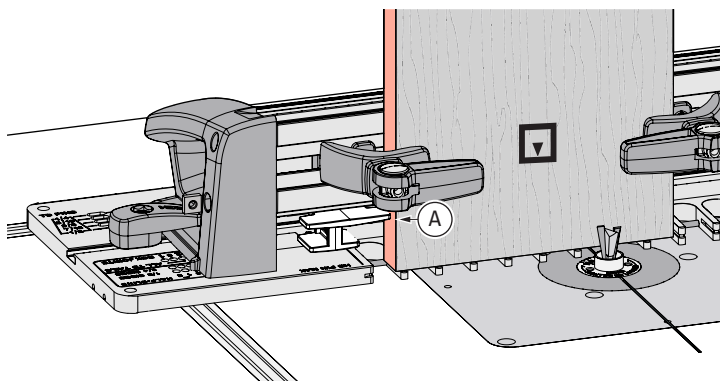

**9-16** Slide the side stop so it lightly touches the tail board and tighten it (A).

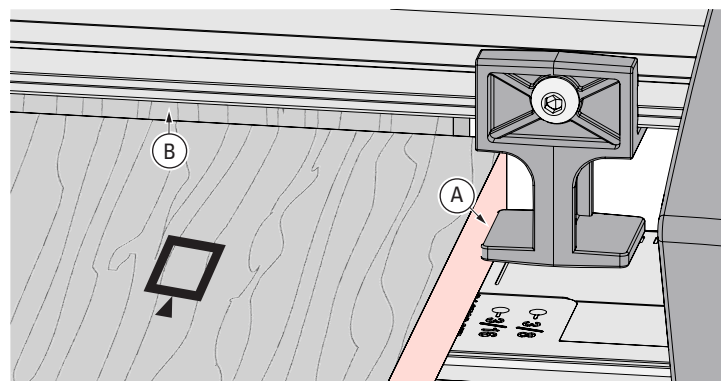

**9-17** Position a **test** pin board against the side stop (A) with the end edge touching **flush against the rear of the tail board** (B), and clamp. **Note: Clamp removed for clarity.**

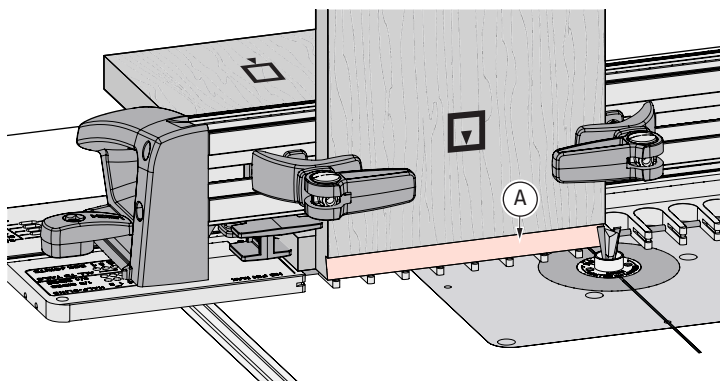

**9-18** Start by routing a very light, shallow climb cut, moving the jig right to left (A). This will leave a nice clean shoulder.  
**⚠ The bit will tend to drive the jig to the right, so make the cut light and with a firm grip.**

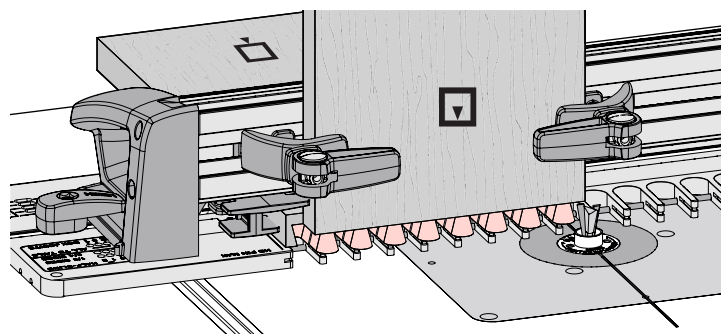

**9-19** Finish routing in and out of all template openings.  
**⚠ The eBush must touch one side of the opening as you enter and the other side as you exit.**

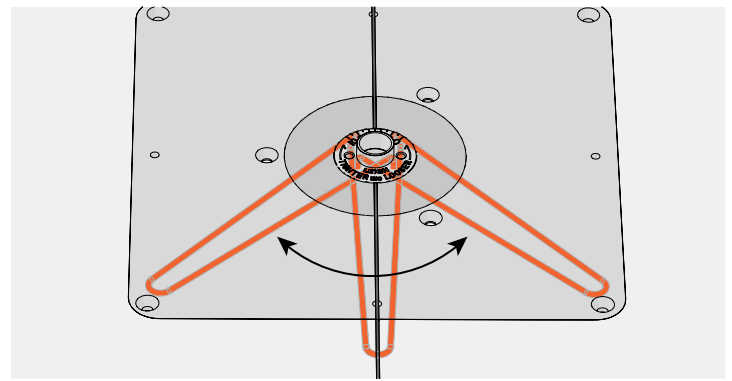
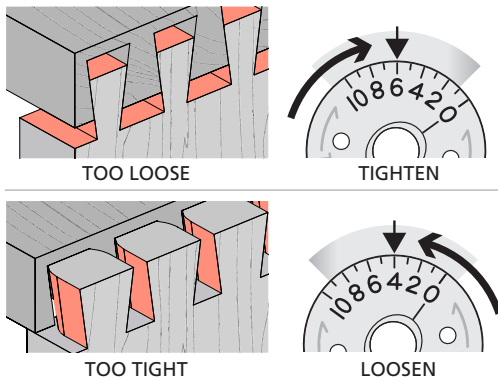

**9-20 Test for Fit** If the joint is too loose, turn the eBush to a higher number with the pin wrench as shown in the next step, and **route two fresh boards**. If the joint is too tight, turn the eBush to a lower number and **route two fresh boards**.

**9-21** Each increment on the eBush changes the joint glue line fit by 0.002" [0.05mm]. Half an increment, a mere 1000th inch! **Re-tighten the eBush nut after each guide bushing adjustment.**

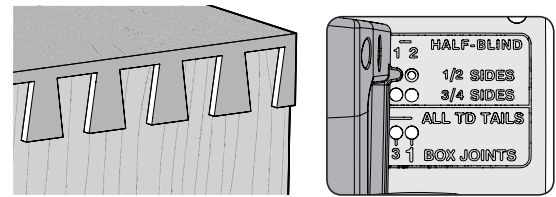
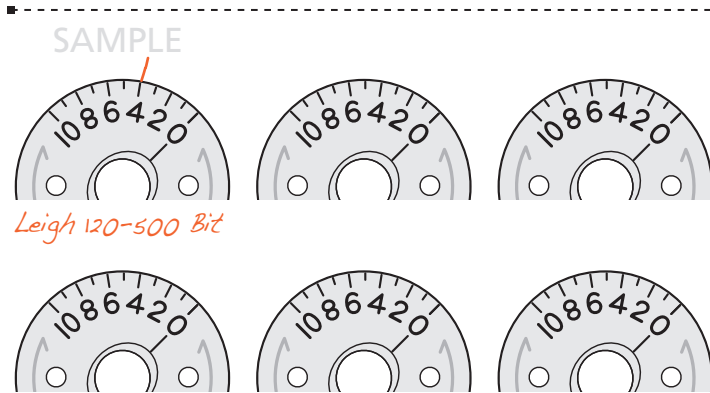

**9-22** Record your perfect fit eBush setting on one of the drawings provided above.

**9-23 Flushness IMPORTANT NOTE:** Do not adjust flushness until correct joint tightness in previous steps is achieved. For **over flush pins**, move the frame pin to a minus (“-”) pin position and rout a new test joint. **⚠ You must re-center the tail board and reposition the side stop every time a reset for flushness is made.** Each pin position changes the joint flushness by 0.013" [0.33mm] Record the pin setting for future use. **Note: Tail board thickness will not affect flushness.**

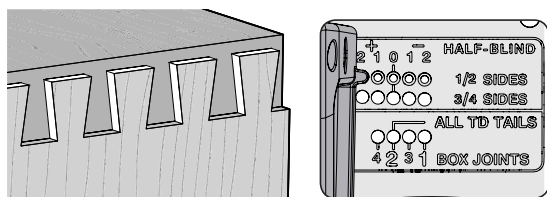

**9-24 Flushness IMPORTANT NOTE:** Do not adjust flushness until correct joint tightness in previous steps is achieved. For **under flush pins**, move the frame pin to a plus (“+”) pin position and rout a new test joint. **⚠ You must re-center the tail board and reposition the side stop every time a reset for flushness is made.** Each pin position changes the joint flushness by 0.013" [0.33mm] Record the pin setting for future use. **Note: Tail board thickness will not affect flushness.**

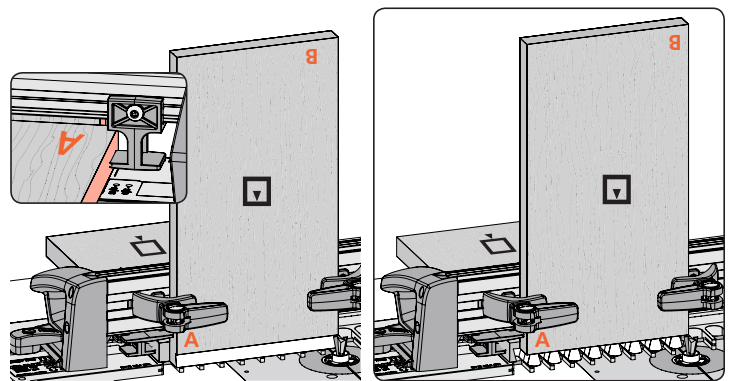

**9-25 Now rout the box.** Left: Insert tail board 1 (corner A). Insert pin board 1 (Inset: corner A). Right: Rout in all openings. **Tail board 1 and pin board 1 are half complete.**

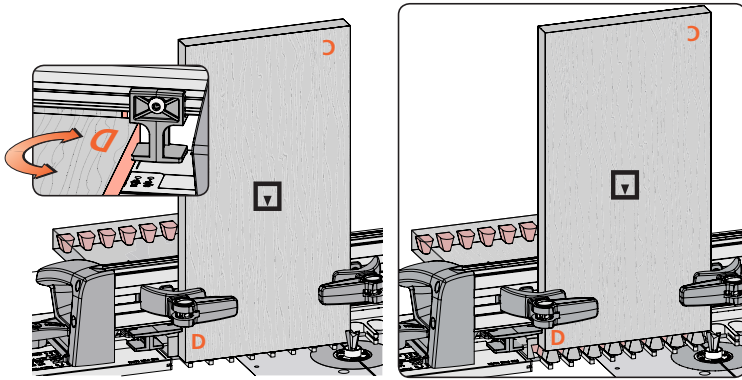

**9-26** Left: Remove tail board 1. Insert tail board 2 (corner D). Rotate pin board 1 (Inset: corner D). Right: Rout in all openings. **Tail board 2 is half complete and pin board 1 is complete.**

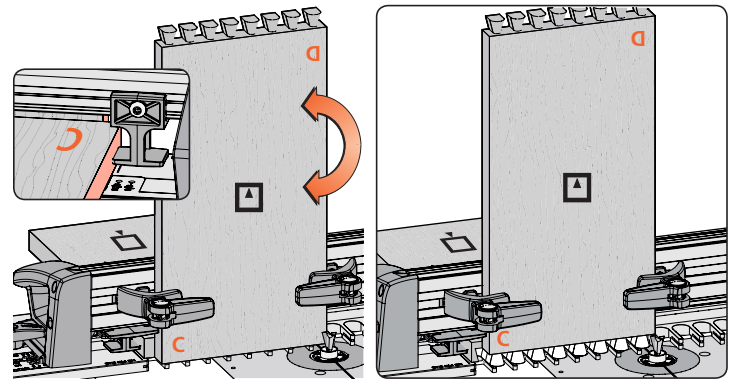

**9-27** Left: Rotate tail board 2 (corner C). Remove pin board 1 and insert pin board 2 (Inset: corner C). Right: Rout in all openings. **Tail board 2 is complete and pin board 2 is half complete.**

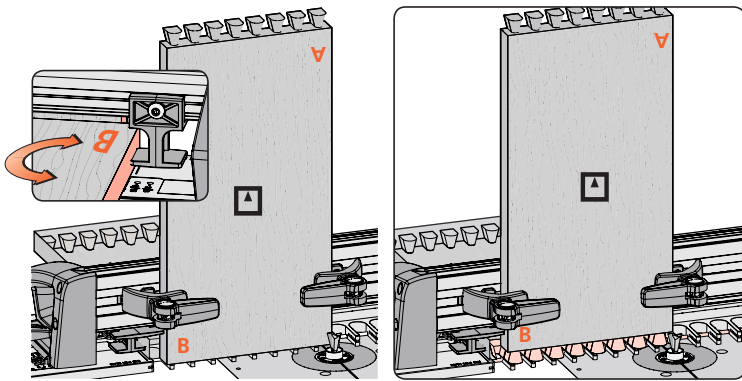

**9-28** Left: Remove tail board 2. Re-insert tail board 1 (corner B). Rotate pin board 2 (Inset: corner B). Right: Rout in all openings. **Tail board 1 and pin board 2 are complete.** All four boards are now complete and ready for assembly. ■

## Rabbeted Half-Blind Dovetails

### 9-29 Getting Started

Review the drawing, opposite, to get an understanding of how the boards fit together and to learn the joinery terms. Before attempting “rabbeted” half-blind dovetails, first master the techniques of half-blind dovetails. Making rabbeted half-blind dovetails is a **two step process** and requires a shop made limit stop. Follow Steps 9-2 to 9-13 and then continue with 9-30.

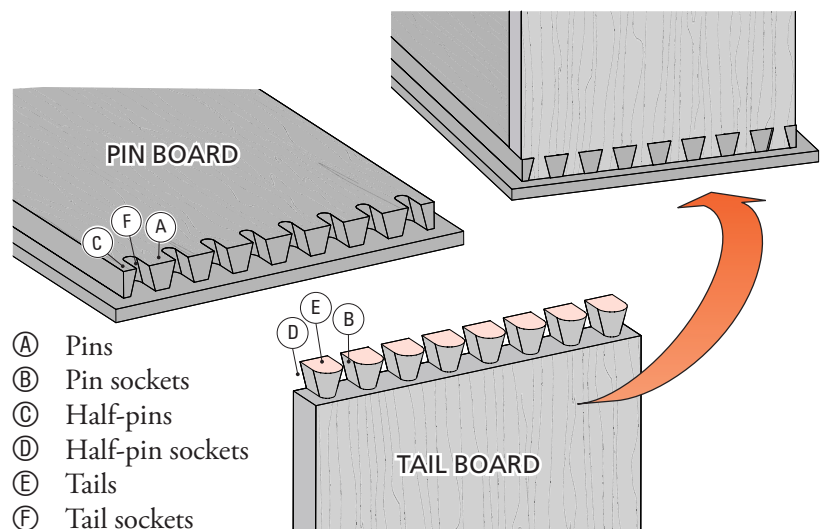
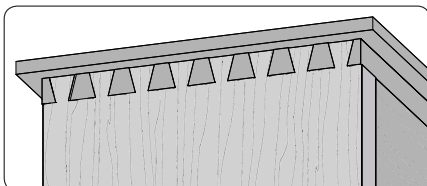



**Rabbeted Half-Blind Dovetails cont.**

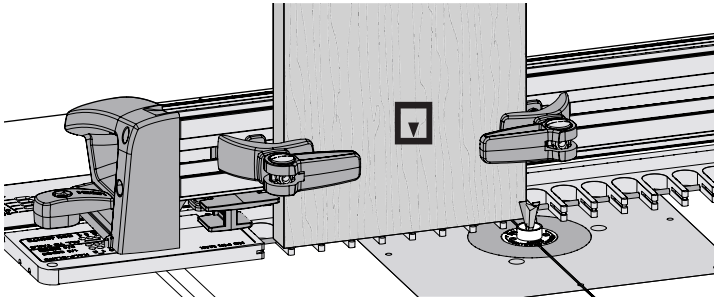

**9-30 Note:** The pin board and tail board are routed separately for rabbeted half-blind joints. Center and clamp a **test** tail board in the jig. Adjust the side stop to touch the right edge of the board and tighten. If you have already determined joint tightness for the dovetail bit you're going to use (in Step 9-22), you don't need to redo the test fit procedure. **Important note:** Choose a bit from Step 9-2 with a depth of cut less than the rabbet thickness.

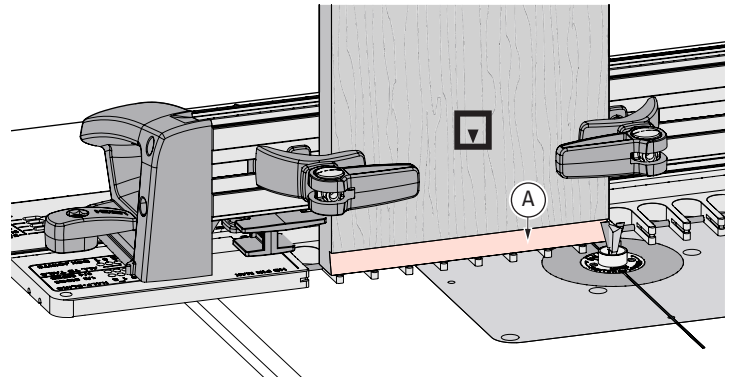

**9-31** Make a very light, shallow climb cut, moving the jig right to left (A). This will leave a nice clean shoulder. **⚠ The bit will tend to drive the jig to the right, so make the cut light and with a firm grip.**

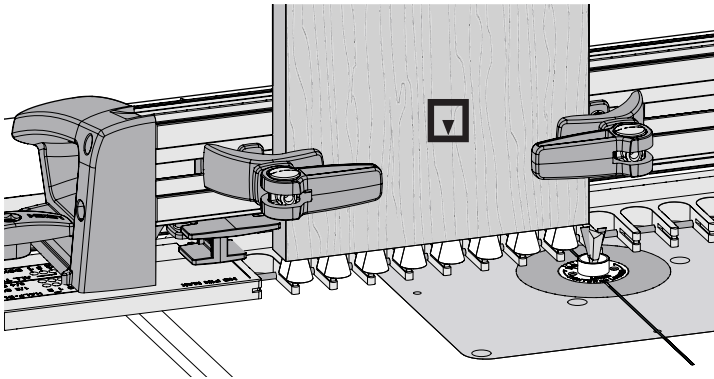

**9-32** Finish the tail board by routing in and out of each template opening, keeping the guide bushing in contact with all template finger surfaces. Remove the tail board.

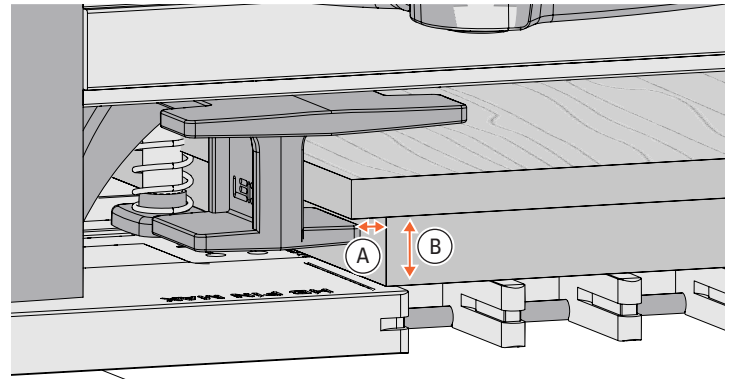

**9-33 Rabbeted Drawer Fronts:** Provided the rabbet on the drawer front is less than 3/8" [9.5mm] wide (A) and more than 3/8" deep (B), the side stop, as previously set on the drawer side, is correctly positioned for the rabbeted pin board.

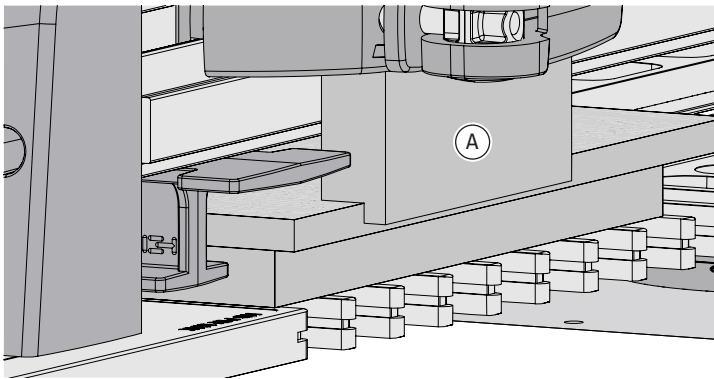

**9-34 Front Limit Stop:** You will need to make a scrap limit stop (A). See the next step for instructions on how to make the front limit stop.

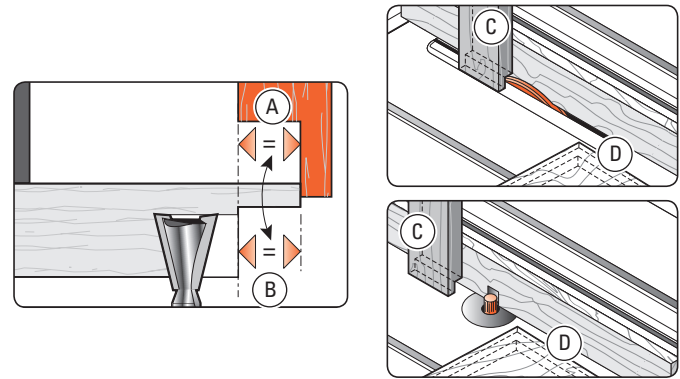

**9-35** Left: The rabbet in the scrap limit stop (A) must be exactly the same width as the rabbet on the drawer front (B). An easy and accurate way to make the limit stop, is to rabbet the end vertically over the router bit or table saw blade (C) immediately after horizontally machining the rabbet in the drawer front (D).

**Rabbeted Half-Blind Dovetails cont.**

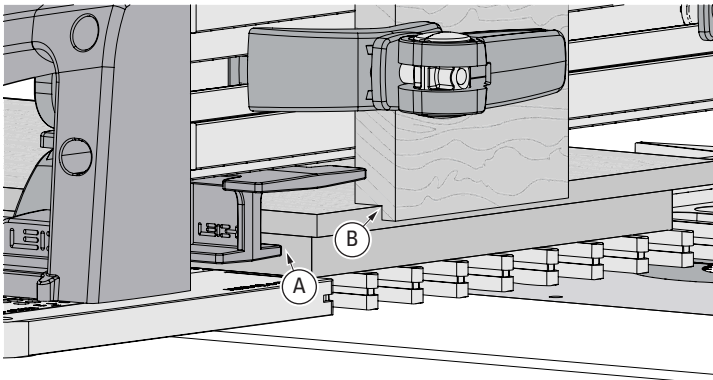

**9-36** Clamp a **test** pin board in the jig against the side stop (A), bringing it forward until it rests against the shop made limit stop (B).

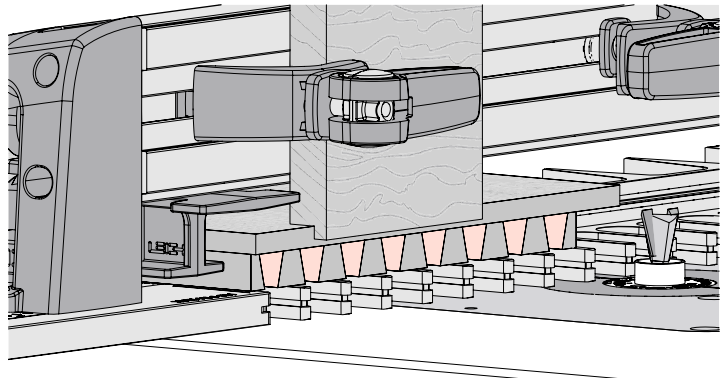

**9-37** Rout in each template opening. ⚠ The eBush must touch one side of the opening as you enter and the other side as you exit.

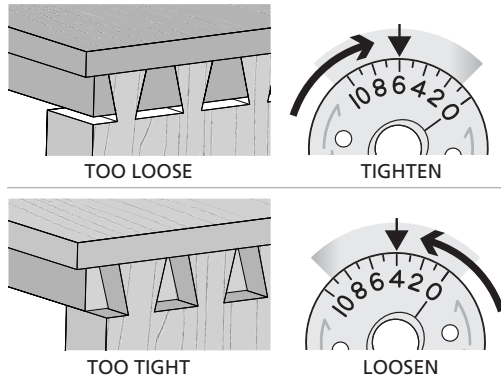

**9-38 Test for Fit** If the joint is **too loose**, turn the eBush to a higher number as shown in the next step, and rout the other end of the test board. If the joint is **too tight**, turn the eBush to a lower number and rout the other end of the test board.

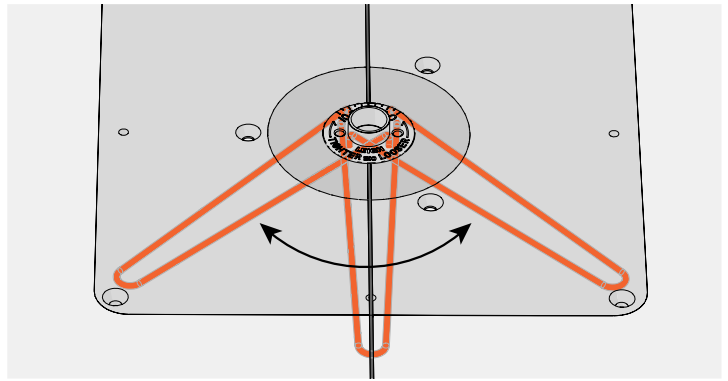

**9-39** Each increment on the eBush changes the joint glue line fit by 0.002" [0.05mm]. Half an increment, a mere 1000th inch! **Re-tighten the eBush nut after each guide bushing adjustment.**

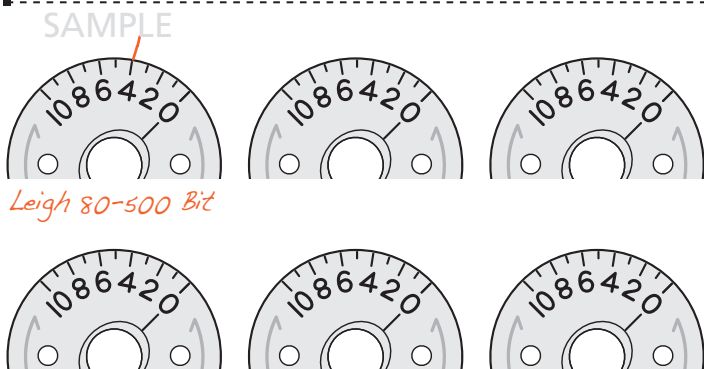

**9-40** Record your perfect fit eBush setting on one of the drawings provided above.

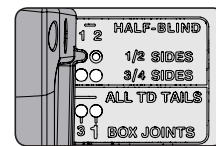
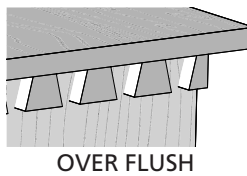

For over flush pins, move frame pin to a minus (“-”) pin position and rout a new test joint.

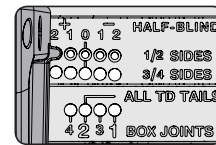
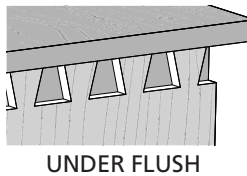

For under flush pins, move frame pin to a plus (“+”) pin position and rout a new test joint.

**9-41 Flushness** ⚠ **IMPORTANT NOTE:** Do not adjust flushness until correct joint tightness in previous steps is achieved. Follow steps shown. **You must reposition the side stop each time a reset for flushness is made.** Each pin position changes the joint flushness by 0.013" [0.33mm] Record the pin setting for future use. **Note: Tail board thickness does not affect flushness.** ■

**RTJ400 OPERATION**

**CHAPTER 10**  
**3/8" Box Joints**

3/8" Box Joints

3/8" Half-Blind Box Joints

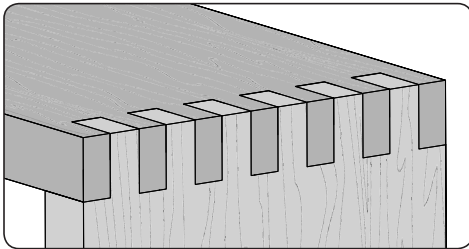

**IMPORTANT SAFETY NOTE**

Before using your Leigh RTJ400 you must have completed the preparatory steps listed in the previous pages, including reading the jig safety recommendations in Chapter 3.

**3/8" Box Joints**

**10-1 Getting Started**

Review the drawing below. **Symmetrical** joints have pins (A) on both edges of one board, and sockets (B) on both edges of the mating board. **Asymmetrical** joints have a pin (C) on one edge and a socket (D) on the other edge of each board.

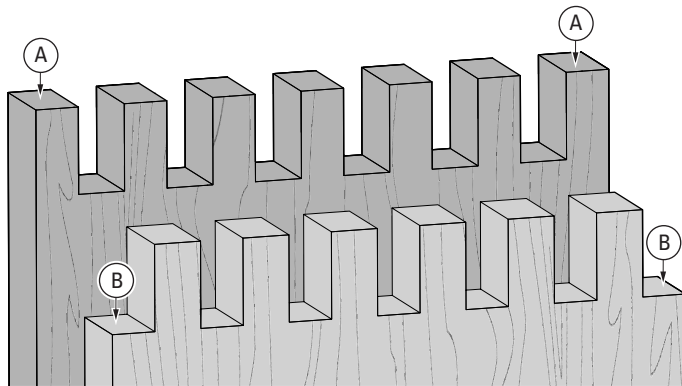

SYMMETRICAL

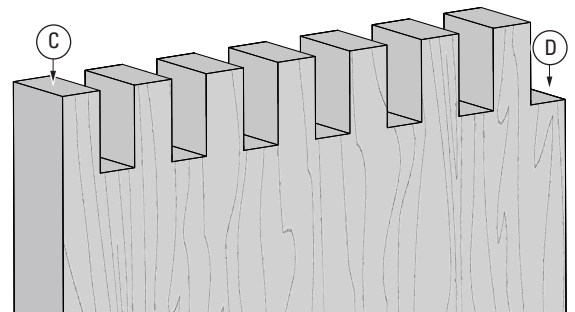

ASYMMETRICAL

**10-2 Bits, Guide Bushing and Stop Rod**

3/8" box joints are routed with the included 3/8" straight bit 143-500, or optional 173-500 or 173-500C bits, the e10 guide bushing (eBush), and the stop rod (for positioning the side stop only). They can be routed in board thicknesses up to the maximum capacity of the RTJ400 Template and the cutting depth of the bit, in this case, 1" [25.4mm].

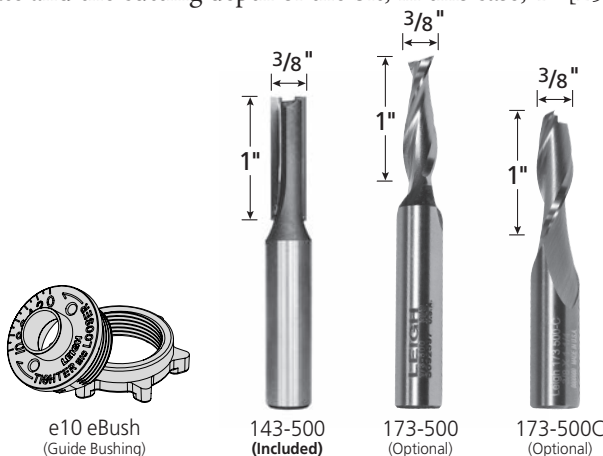

BOX JOINT BIT CUTTING DEPTH	
Bit Diameter	3/8"
Item No. Carbide Tipped	<b>143-500</b>
Item No. Spiral HSS (Optional)	<b>173-500</b>
Item No. Spiral Solid Carbide (Optional)	<b>173-500C</b>
Depth of Cut	0" -----
	1/4" -----
	1/2" -----
	3/4" -----
	1" -----

### 10-3 Board Width Selection

Board widths are determined by the total number of pins and sockets in the joint design and whether the joint is symmetrical or asymmetrical. Use this chart to determine board widths up to 16" [406mm].

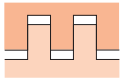

**Symmetrical Joints** have a full pin at each board edge. The total number of pins and sockets is always an odd number.

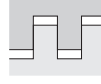

**Asymmetrical joints** have a full pin on one edge and a full socket on the other edge. The total number of pins and sockets is always an even number.

#### Symmetrical Board Width Chart for 3/8" Box Joints

Total Pins & Sockets	3	5	7	9	11	13	15	17	19	21	23	25	27	29	31	33	35	37	39	41
Inches	1 1/32"	1 15/16"	2 23/32"	3 1/2"	4 9/32"	5 1/16"	5 27/32"	6 5/8"	7 13/32"	8 3/16"	8 31/32"	9 3/4"	10 17/32"	11 5/16"	12 3/32"	12 7/8"	13 29/32"	14 7/16"	15 7/32"	16
Millimeters	29	49	69	89	109	129	148	168	188	208	228	248	267	287	307	327	347	367	387	406

#### Asymmetrical Board Width Chart for 3/8" Box Joints

Total Pins & Sockets	4	6	8	10	12	14	16	18	20	22	24	26	28	30	32	34	36	38	40
Inches	1 1/16"	2 11/32"	3 1/8"	3 29/32"	4 11/16"	5 15/32"	6 1/4"	7 1/32"	7 13/16"	8 19/32"	9 3/8"	10 5/32"	10 15/16"	11 23/32"	12 1/2"	13 9/32"	14 1/16"	14 27/32"	15 5/8"
Millimeters	40	60	79	99	119	139	159	179	198	218	238	258	279	298	318	337	357	377	397

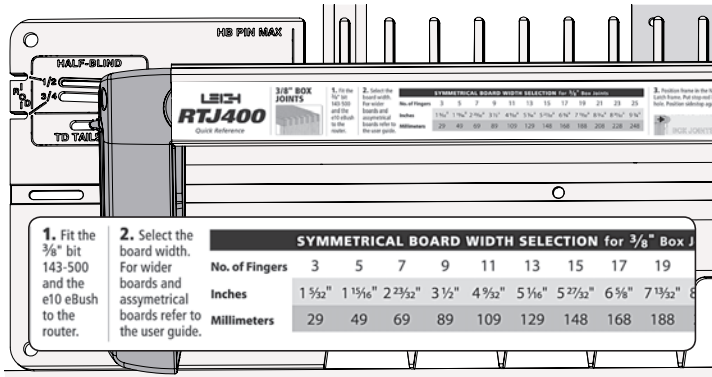

**10-4** Use the Quick Reference strip to determine the correct straight bit and eBush combination.

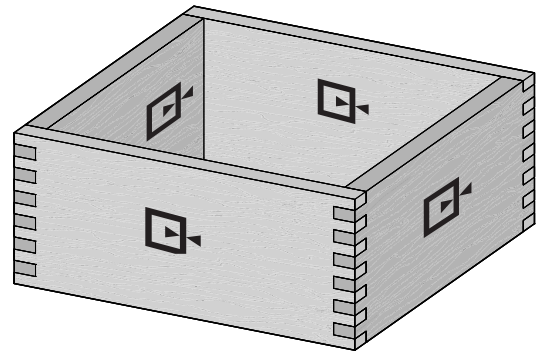

**10-5 Making a Box** Note the symbols indicating either side of the pin and socket boards can face in or out. With box joints, the same edge of the board goes against the side stop.

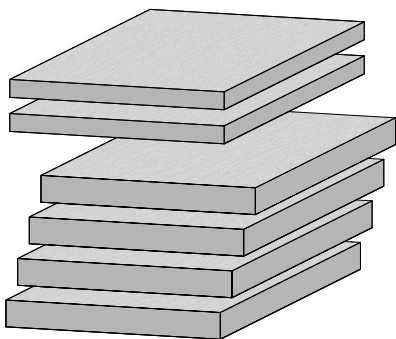

**10-6** Prepare four similar boards 3/4" x 5 1/16" by about 12" long [19mm x 129mm x 305mm]. For the quick fit test you will need two test boards about 1/2" thick. Boards of different thicknesses may also be joined.

**IMPORTANT:** Read this whole chapter before routing any boards.

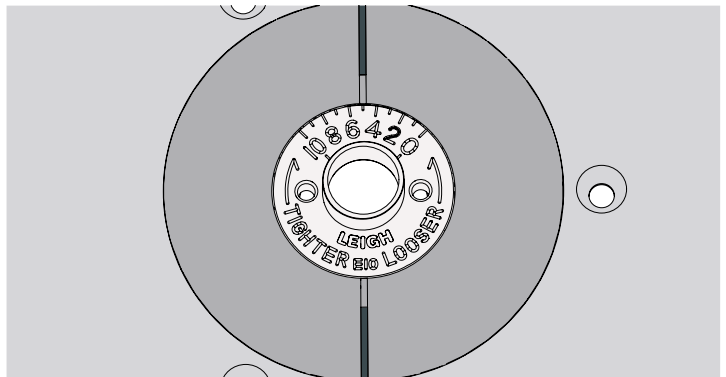

**10-7** Fit the e10 eBush to the router table insert ring, set to 5.

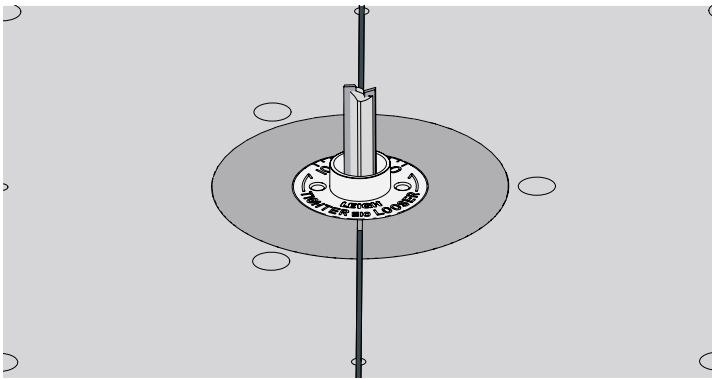

**10-8** With the router unplugged, install the supplied  $\frac{3}{8}$ " Leigh 143-500 bit. For cleaner routing use the optional  $\frac{3}{8}$ " Leigh 173-500 (HSS) or 173-500C (solid carbide) spiral upcut bit, available at leighjigs.com. ⚠ Make sure the bit spins freely before connecting the power.

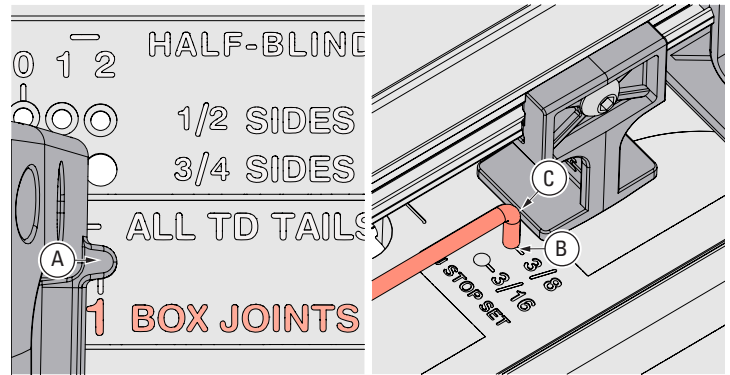

**10-9** Insert the right frame pin in the **No.1 BOX JOINTS** hole (A) and the left frame pin in the **HALF-BLIND & BJ** slot. Latch the frame. Put the short end of the stop rod into the **3/8" B J STOP SET** hole (B). Slide the side stop to lightly touch the rod (C) and tighten the side stop. Store the stop rod in the  $\frac{3}{4}$ " slot.

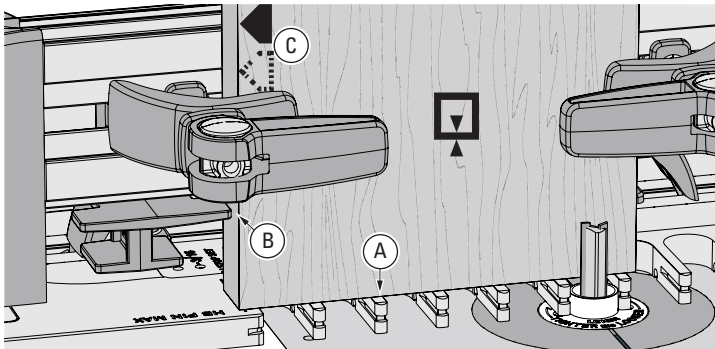

**10-10** Clamp pin board 1 flush on the template (A) with the side edge against the side stop (B). **Always keep the same side edge of the board to the side stop when routing box joints (C).** If the board width is only slightly narrower than the chart width, center the board over the template, clamp in place and move the side stop against the board.

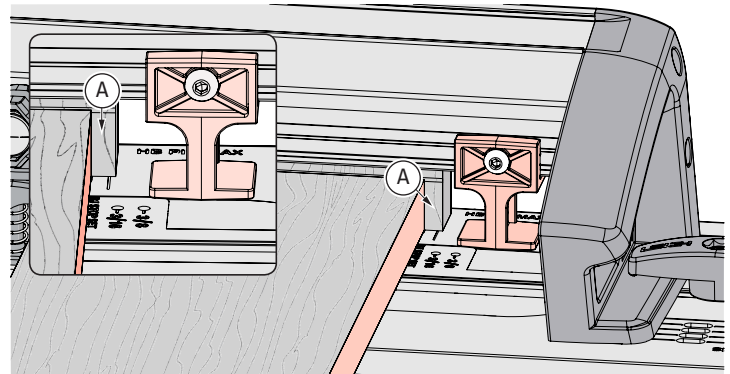

**10-11** Position a backer board  $\frac{1}{16}$ " [1.5mm] away from the edge of the pin board (A). This prevents the backer board from interfering with the side stop when the frame is repositioned in the second step. The backer board stays in place for the complete procedure. **Note: Clamp removed for clarity.**

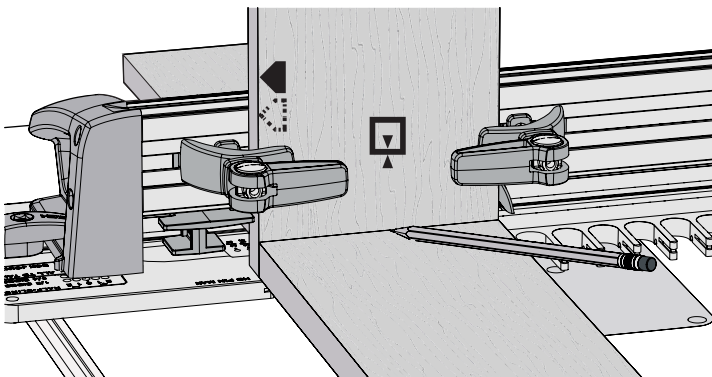

**10-12** Place the end of a socket board on the template and pencil a line on the pin board.

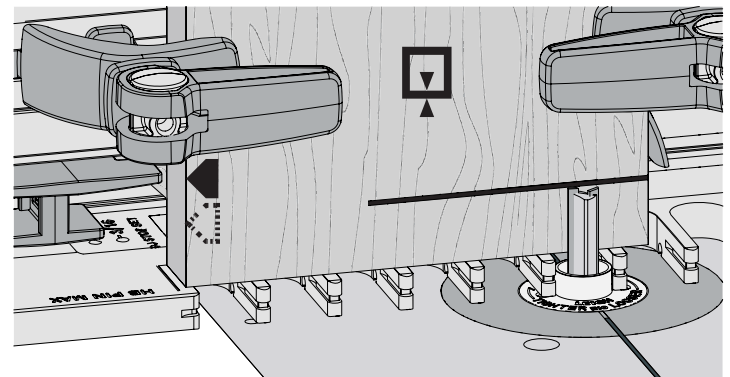

**10-13** Adjust the bit to the center of the pencil line. ⚠ Double check that the bit still rotates freely. **IMPORTANT: Bit height determines the flushness of the joint, so set your bit properly the first time.** Adjustments for flushness are at the end of the chapter.

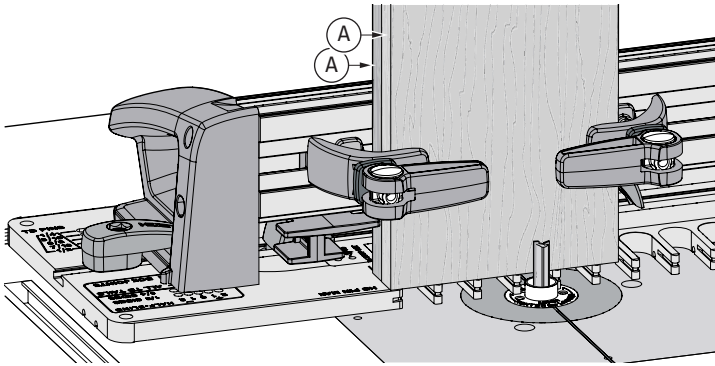

**10-14 Quick Fit Test** To save time and wood, clamp two ½" thick scrap boards in the jig, back to back (A). **⚠ First review the remaining steps up to 10-20.** Rout both boards at the same time. Test the boards for joint fit, and make joint fit adjustments (steps 10-15 to 10-17). Don't worry about board edge alignment, the test is for joint fit only.

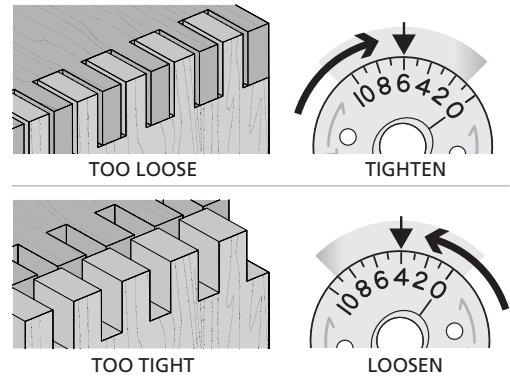

**10-15 Joint Fit Adjustment** Keep the same side board edges together. If the joint is too loose, turn the eBush to a higher number, as shown in the next step. If too tight, turn the eBush to a lower number.

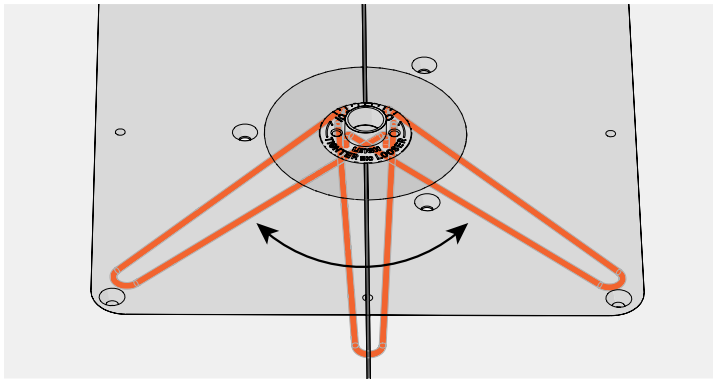

**10-16** Each increment on the eBush changes the joint glue line fit by 0.002" [0.05mm]. Half an increment, a mere 1000th inch! **Re-tighten the eBush nut after each guide bushing adjustment.**

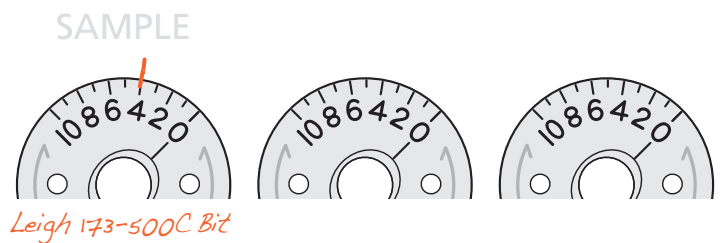

**10-17** On the eBushes above, record the settings you used to achieve perfect joint fit. The first eBush is simply an example of how to record your setting.

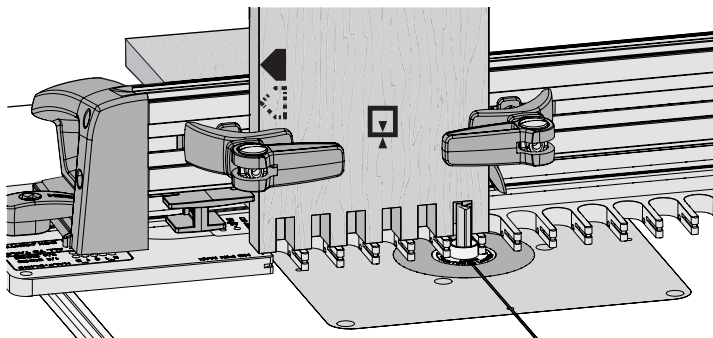

**10-18** Now that your joint tightness has been determined, re-clamp pin board 1 in position and rout into all of the openings. **⚠ The eBush must touch one side of the opening as you enter and the other side as you exit.** Flip the board, keeping the same edge against the side stop, and rout the other end. Remove pin board 1 and repeat the procedure with pin board 2. Remove pin board 2.

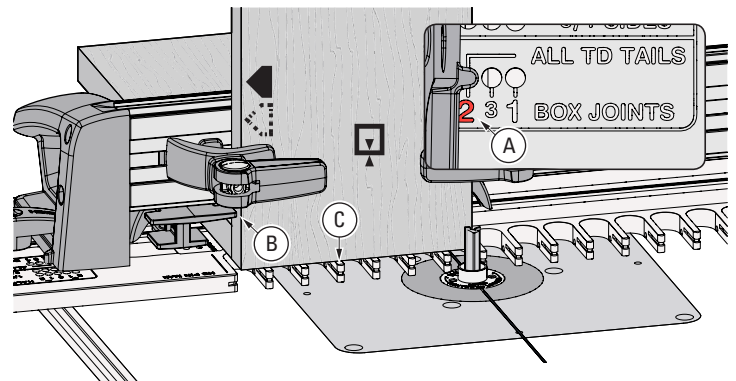

**10-19** Unlatch and move the right frame pin to the **No.2 hole** in the **BOX JOINTS** mode (A). Latch the frame. Clamp socket board 1 against the side stop (B), flush on the template (C).

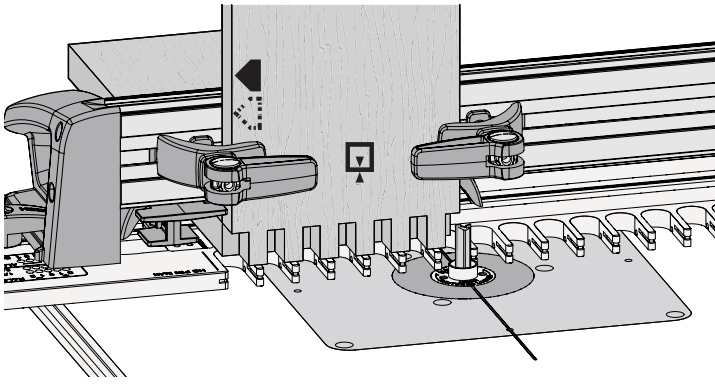

**10-20** Rout the sockets making sure to contact both sides of each opening with the guide bushing. Flip the board and rout the other end. Repeat the procedure for socket board 2. All four boards are now complete and ready for assembly.

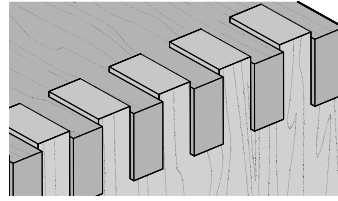

OVER FLUSH

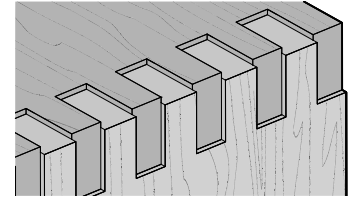

UNDER FLUSH

**10-21 Flushness** If the joint is over flush, lower the bit to suit. If the joint is under flush, raise the bit to suit. Rout a fresh test joint until fit and flushness are perfect before routing the actual workpieces. ■

---

**NOTE:** See  $\frac{3}{8}$ " Half-Blind Box Joints section on the next page.

### 3/8" Half-Blind Box Joints

#### 10-22 Getting Started

Review the drawing opposite, to get a clear understanding of how the boards fit together and to learn the joinery terms.

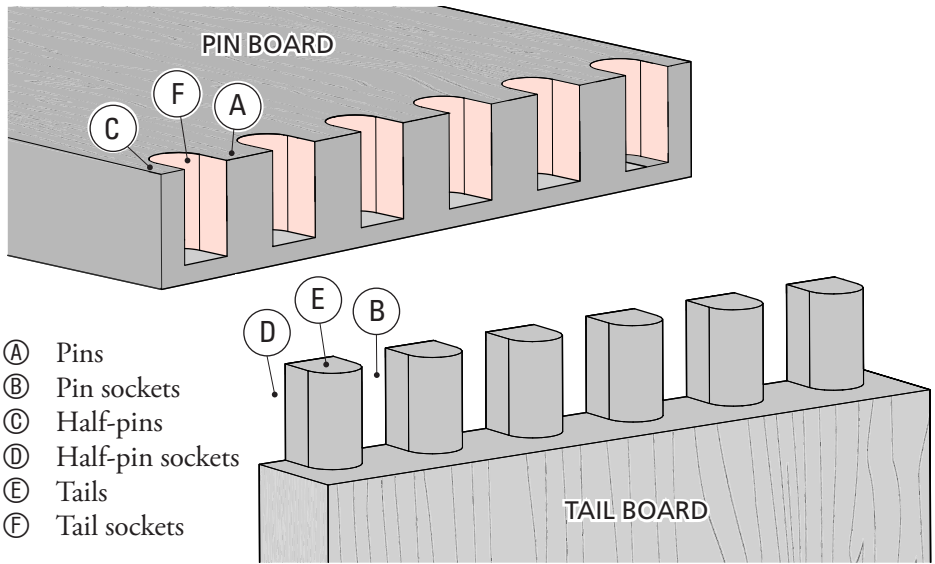
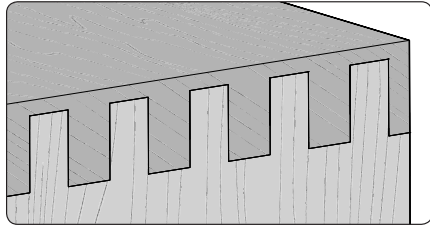

#### 10-23 Bits, Guide Bushing and Stop Rod

To rout 3/8" half-blind box joints, use the included 3/8" straight bit 143-500 or optional 173-500 or 173-500C bits, the e10 guide bushing (eBush) and stop rod. They can be routed in board thicknesses up to the maximum cutting depth of the bit, in this case, 1" [25.4mm].



Stop Rod

e10 Guide Bushing (eBush)



143-500 (Included)

173-500 (Optional)

173-500C (Optional)

BOX JOINT BIT CUTTING DEPTH	
Bit Diameter	3/8"
Item No. Carbide Tipped	143-500
Item No. Spiral HSS (Optional)	173-500
Item No. Spiral Solid Carbide (Optional)	173-500C
Depth of Cut	0" -----
	1/4" -----
	1/2" -----
	3/4" -----
	1" -----

#### 10-24 Board Width Selection

Half-blind box joints may be routed in boards up to 1" thick [25.4mm]. Use this chart to determine the best board width, up to a maximum of 16" [406mm]. Board widths are based on the number of full tails (A) in the joint design. Board edges always end with a half pin (B). Board widths in the chart below may be increased by 3/8" [6mm] or decreased by 1/8" [3mm] if required.

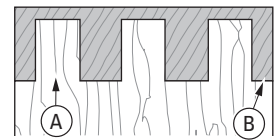

Board Width Selection for 3/8" Half-Blind Box Joints																					
No. of Tails		1	2	3	4	5	6	7	8	9	10	11	12	13	14	15	16	17	18	19	20
Inches	Min	2 1/32"	1 7/16"	2 7/32"	3"	3 29/32"	4 9/16"	5 11/32"	6 1/4"	6 29/32"	7 11/16"	8 15/32"	9 1/4"	10 1/32"	10 13/16"	11 19/32"	12 3/8"	13 5/32"	13 15/16"	14 23/32"	15 1/2"
	Exact	2 5/32"	1 9/16"	2 11/32"	3 1/8"	3 29/32"	4 11/16"	5 15/32"	6 1/4"	7 1/32"	7 13/16"	8 19/32"	9 3/8"	10 5/32"	10 15/16"	11 23/32"	12 1/2"	13 9/32"	14 1/16"	14 27/32"	15 5/8"
	Max	1 1/2"	1 13/16"	2 19/32"	3 3/8"	4 3/32"	4 15/16"	5 23/32"	6 1/2"	7 11/16"	8 1/16"	8 27/32"	9 5/8"	10 13/32"	11 1/16"	11 31/32"	12 3/4"	13 17/32"	14 1/16"	15 3/32"	15 7/8"
Millimeters	Min	17	37	56	76	96	116	136	155	175	195	215	234	254	274	294	313	333	353	373	392
	Exact	20	40	60	79	99	119	139	158	178	198	217	237	257	277	297	316	336	356	376	395
	Max	26	45	65	85	105	124	144	164	184	203	223	243	263	282	302	322	342	361	381	401



3/8" Half-Blind Box Joints cont.

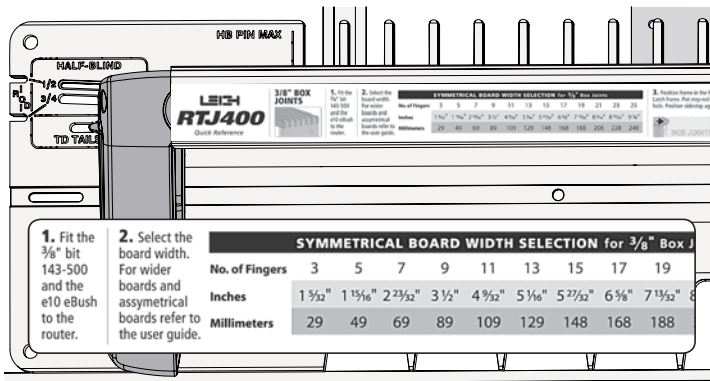

**10-25** Half-blind box joints are made using the same bit and eBush as 3/8" box joints, however the **HALF-BLIND** section of the template is used.

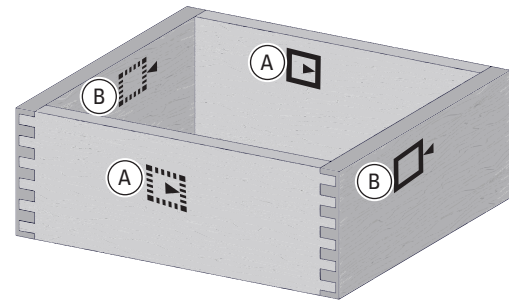

**10-26** Note the symbols indicating the inside or outside of the pin and tail boards. To make a box you will need to mark these symbols on the inside faces of the tail boards (A) and outside faces of the pin boards (B).

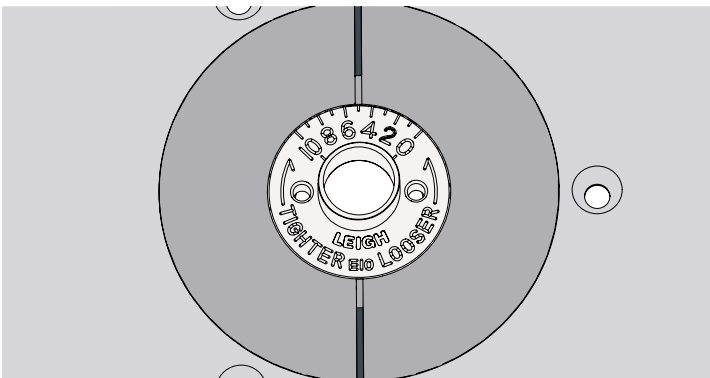

**10-27** Fit the e10 eBush to the router table insert ring. If you have already determined the correct fit in the 3/8" box joint chapter, use that setting, or alternatively use the Quick Fit Test, Step 10-14.

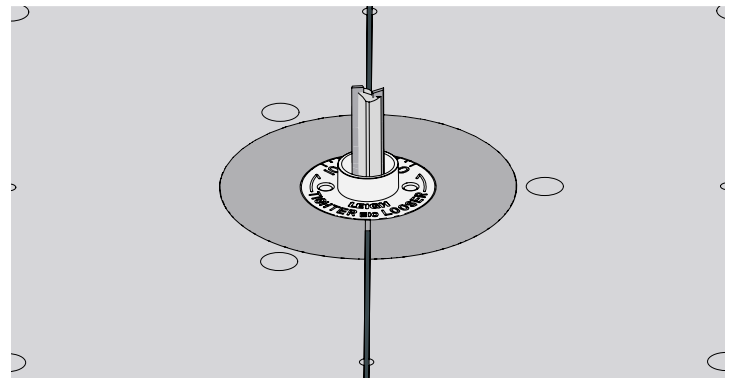

**10-28** With the router unplugged, install the supplied 3/8" Leigh 143-500 bit. For cleaner routing use the optional 3/8" Leigh 173-500 (HSS) or 173-500C (solid carbide) spiral upcut bit, available at leighjigs.com. ⚠ Make sure the bit spins freely before connecting the power.

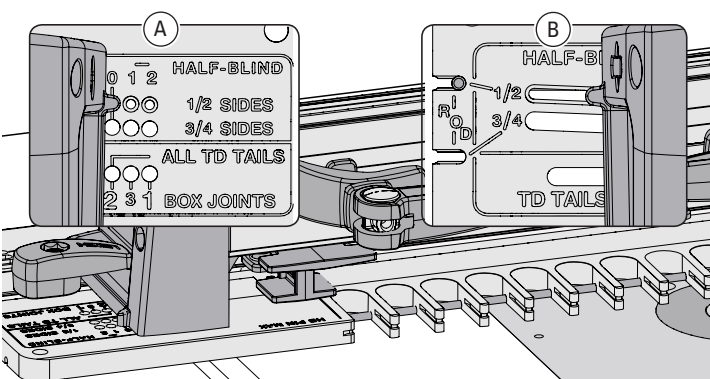

**10-29** Insert the right frame pin in the 1/2" **HALF-BLIND** "0" pin hole (A) and the left frame pin in the 1/2" **HALF-BLIND** slot (B). Latch the frame. **Note: The HALF-BLIND pin hole settings refer only to the thickness of the pin board (drawer side).**

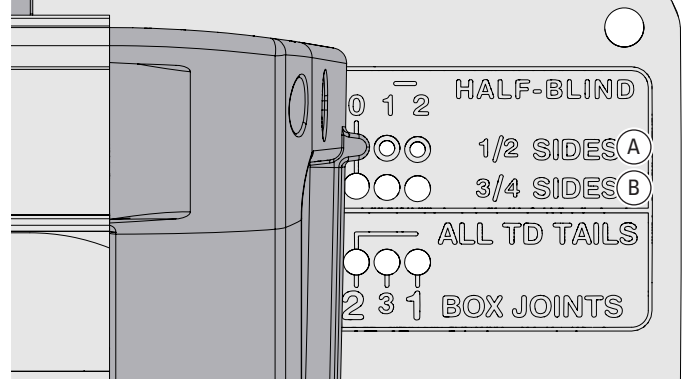

**10-30 NOTE:** Use the 1/2" row (A) for tail boards 3/8" [11mm] to 5/8" [16mm] thick, and the 3/4" row (B) for tail boards 11/16" [17.5mm] to 7/8" [22mm] thick.

## 3/8" Half-Blind Box Joints cont.

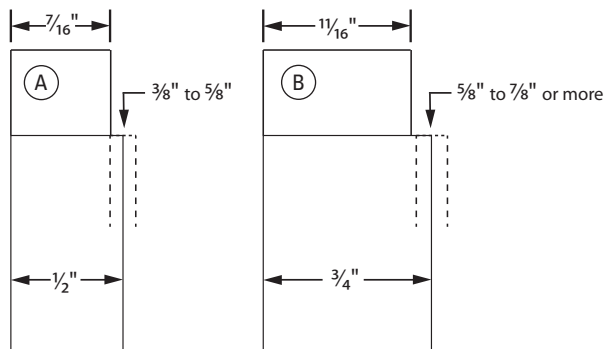

**10-31** When the frame pin and stop rod are in the  $\frac{1}{2}$ " positions, all tails will be  $\frac{7}{16}$ ", dimension **A**, regardless of actual board thickness (dashed line). Similarly, when the frame pin and stop rod are in the  $\frac{3}{4}$ " hole, all tails will be  $1\frac{1}{16}$ ", dimension **B**, regardless of actual board thickness.

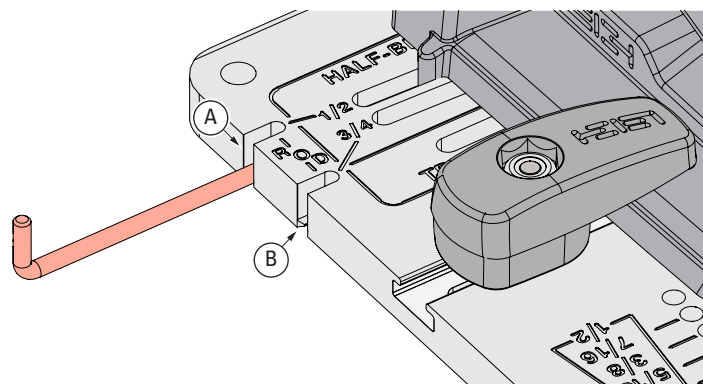

**10-32 The Stop Rod.** For tail boards from  $\frac{3}{8}$ " [11mm] to  $\frac{5}{8}$ " [16mm] thick, insert the stop rod in the  $\frac{1}{2}$ " slot **A**. **Note: For tail boards  $1\frac{1}{16}$ " [17.5mm] thick or greater, the stop rod is stored in the  $\frac{3}{4}$ " slot **B**.**

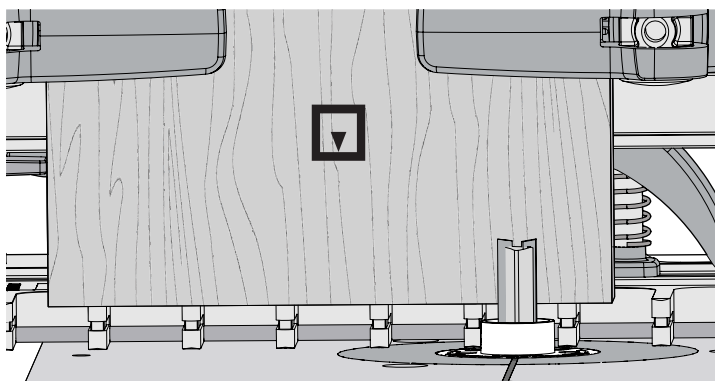

**10-33** Center the tail board over the template so that the side edges are equally spaced over the template fingers and touching flush on the template. Clamp the tail board.

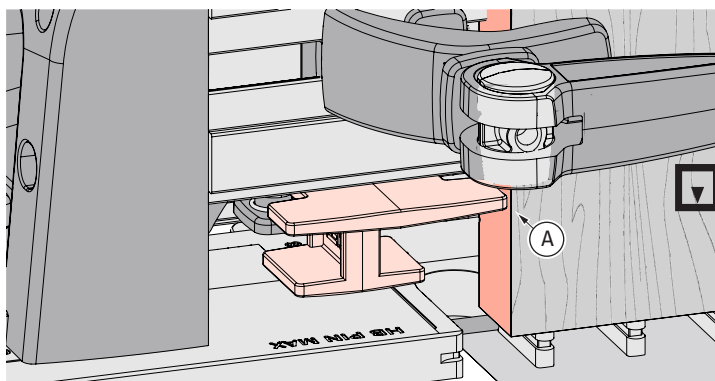

**10-34** Slide the side stop so it lightly touches against the tail board and tighten it. **A**.

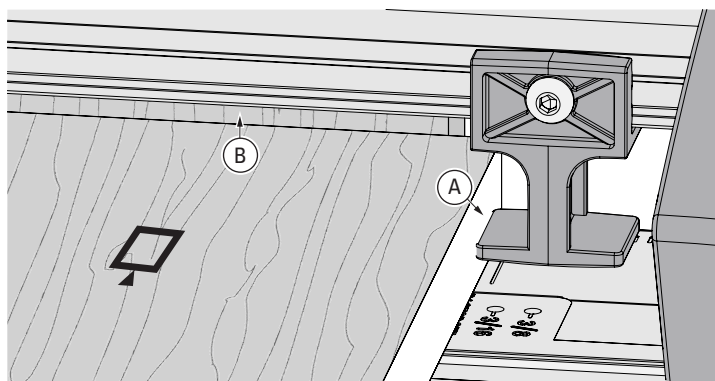

**10-35** Position the pin board against the side stop **A** with the end edge touching **flush against the rear of the tail board** **B**, and clamp. **Note: Clamp removed for clarity.**

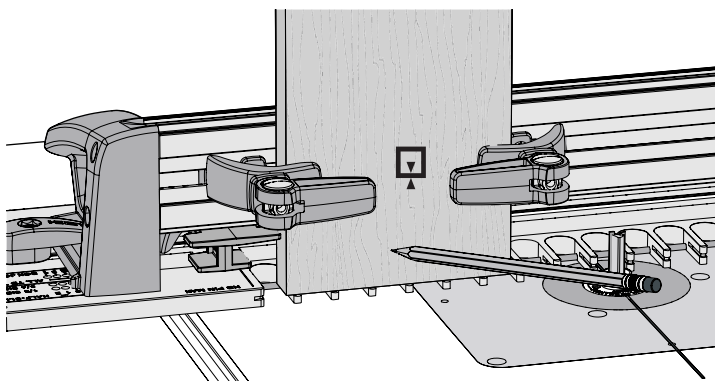

**10-36** The depth of cut (how much the tail board intersects the pin board) is arbitrarily set. Our suggestion is to set the depth of cut about  $\frac{1}{8}$ " less than the thickness of the pin board or in the case of lipped drawer fronts, slightly lower than the lip. In this case our pin board is  $\frac{3}{4}$ ", so mark a line up from the end of the tail board  $\frac{5}{8}$ ".

Half-Blind Box Joints cont.

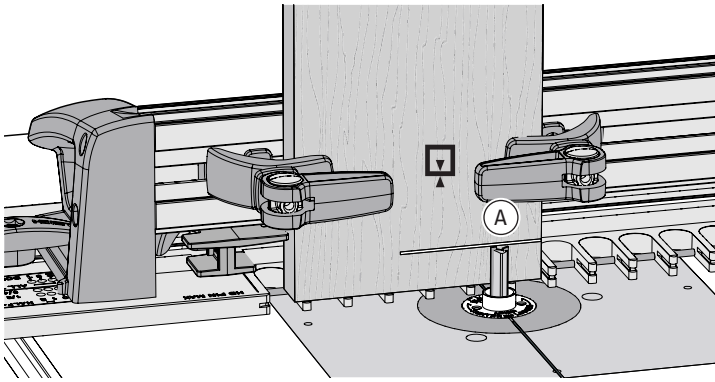

**10-37** Adjust the bit to the center of the line (A).

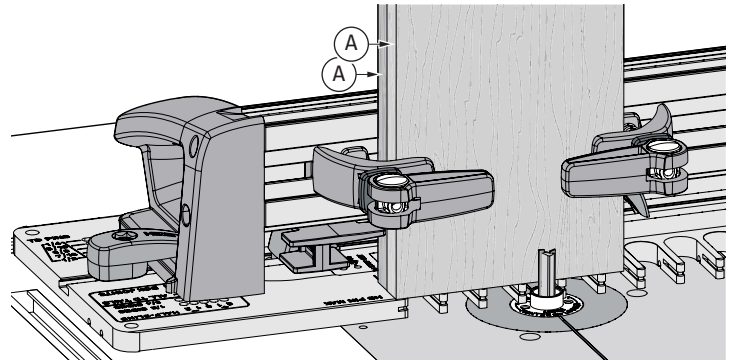

**10-38 Quick Fit Test** To save time and wood, clamp the two 1/2" thick scrap **test** boards in the jig, back to back (A). Rout both boards at the same time. Join the routed boards and make joint fit adjustments in the next three steps. Don't worry about board edge alignment, the test is for joint fit only. **Note:** If you have already done the Quick Fit Test in Step 10-17, use that eBush setting.

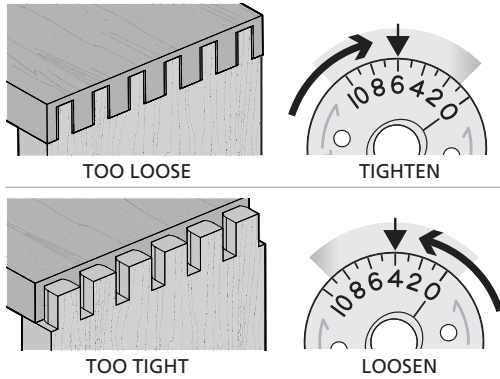

**10-39 Test for Fit** If the joint is too loose, turn the eBush to a higher number with the pin wrench as shown in the next step, and **rout two fresh boards**. If the joint is too tight, turn the eBush to a lower number and **rout two fresh boards**.

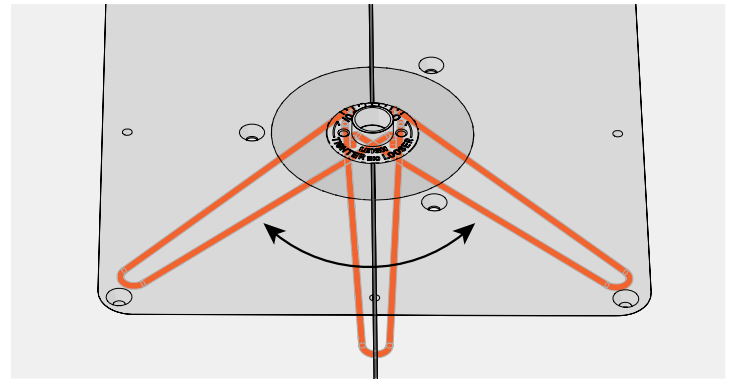

**10-40** Each increment on the eBush changes the joint glue line fit by 0.002" [0.05mm]. Half an increment, a mere 1000th inch! **Re-tighten the eBush after each guide bushing adjustment.**

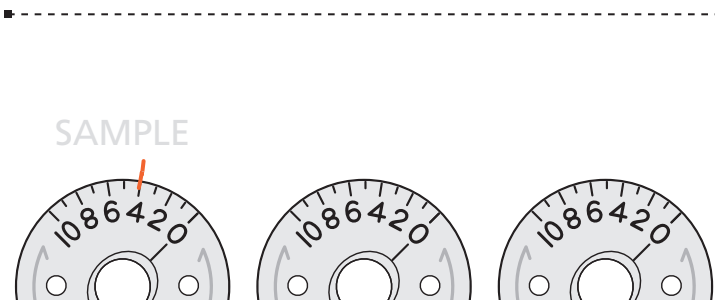

Leigh 173-500C Bit

**10-41** Record your perfect fit eBush setting on one of the drawings provided above.

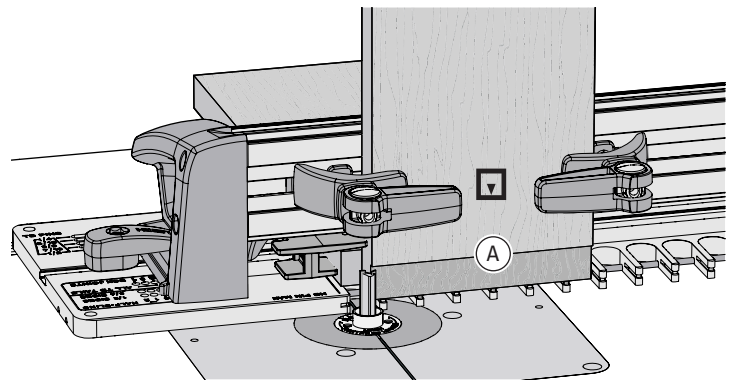

**10-42** Re-clamp the tail board in position. Start by routing a very light, shallow climb cut, moving the jig right to left (A). This will leave a nice clean shoulder.

**⚠ The bit will tend to drive the jig to the right, so make the cut light and with a firm grip.**

### 3/8" Half-Blind Box Joints cont.

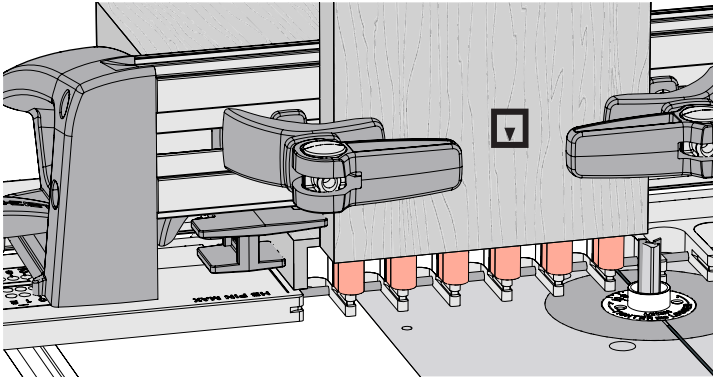

**10-43** Finish routing in and out of all template openings. **⚠** The eBush must touch one side of the opening as you enter and the other side as you exit.

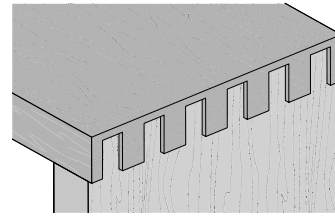

OVER FLUSH

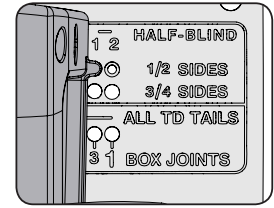

**10-44** Flushness **IMPORTANT NOTE:** Do not adjust flushness until correct joint tightness in previous steps is achieved. For over flush tails, move the frame pin to a minus (“-”) tail position and rout a new test joint. **⚠** **You must re-center the tail board and reposition the side stop every time a reset for flushness is made.** Each pin position changes the joint flushness by 0.013"[0.33mm] Record the pin setting for future use.

**Note: Tail board thickness will not affect flushness.**

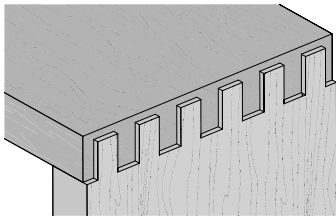

UNDER FLUSH

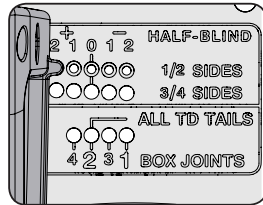

**10-45** Flushness **IMPORTANT NOTE:** Do not adjust flushness until correct joint tightness in previous steps is achieved. For under flush tails, move the frame pin to a plus (“+”) pin position and rout a new test joint. **⚠** **You must re-center the tail board and reposition the side stop every time a reset for flushness is made.** Each pin position changes the joint flushness by 0.013"[0.33mm] Record the pin setting for future use.

**Note: Tail board thickness will not affect flushness. ■**

**RTJ400 OPERATION**

**CHAPTER 11**  
**3/4" Box (Finger) Joints**

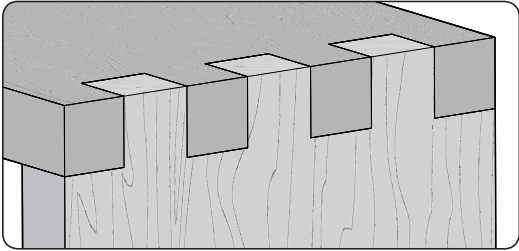

**IMPORTANT SAFETY NOTE**  
Before using your Leigh RTJ400 you must have completed the preparatory steps listed in the previous pages, including reading the jig safety recommendations in Chapter 3.

**11-1 Getting Started**

Review the drawing below. **Symmetrical** joints have pins (A) on both edges of one board, and sockets (B) on both edges of the mating board. **Asymmetrical** joints have a pin (C) on one edge and a socket (D) on the other edge of each board.

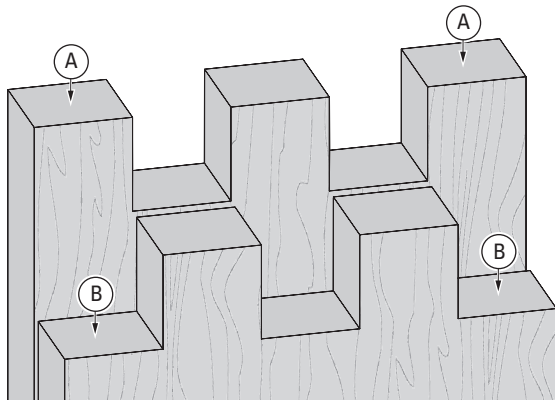

SYMMETRICAL

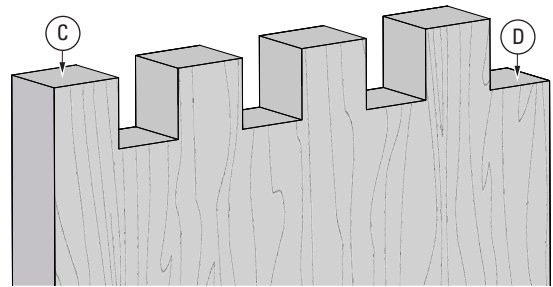

ASYMMETRICAL

**11-2 Bits, Guide Bushing, Blockers and Stop Rod**

3/4" box joints are routed with the included 3/8" straight bit 143-500 or optional 173-500 or 173-500C bits, the e10 guide bushing (eBush), blockers and stop rod (for positioning the side stop only). They can be routed in board thicknesses up to the maximum cutting depth of 1" [25.4mm].

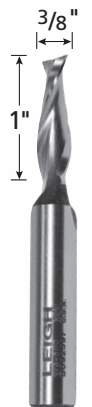
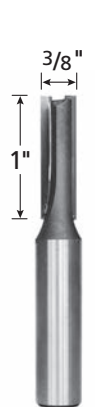
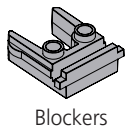

BOX JOINT BIT CUTTING DEPTH	
Bit Diameter	3/8"
Item No. Carbide Tipped	143-500
Item No. Spiral HSS (Optional)	173-500
Item No. Spiral Solid Carbide (Optional)	173-500C
Depth of Cut	0" -----
	1/4" -----
	1/2" -----
	3/4" -----
	1" -----

Stop Rod  
(For positioning side stop)

### 11-3 Board Width Selection

Board widths are determined by the total number of pins and sockets in the joint design and whether the joint is symmetrical or asymmetrical. Use this chart to determine board widths up to 15 5/8" [397mm].

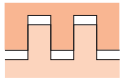

**Symmetrical Joints** have a full pin at each board edge. Total number of pins and sockets is always an odd number.



**Asymmetrical joints** have a full pin on one edge and a full socket on the other edge. Total number of pins and sockets is always an even number.

Symmetrical Board Width Chart for 3/4" Box Joints									
Total Pins & Sockets	3	5	7	9	11	13	15	17	19
Inches	2 1/32"	3 29/32"	5 15/32"	7 1/32"	8 19/32"	10 9/32"	11 23/32"	13 3/32"	14 27/32"
Millimeters	60	99	139	179	218	258	298	337	377

Asymmetrical Board Width Chart for 3/4" Box Joints									
Total Pins & Sockets	4	6	8	10	12	14	16	18	20
Inches	3 1/8"	4 11/16"	6 1/4"	7 13/16"	9 3/8"	10 15/16"	12 1/2"	14 1/16"	15 5/8"
Millimeters	79	119	159	198	238	278	318	357	397

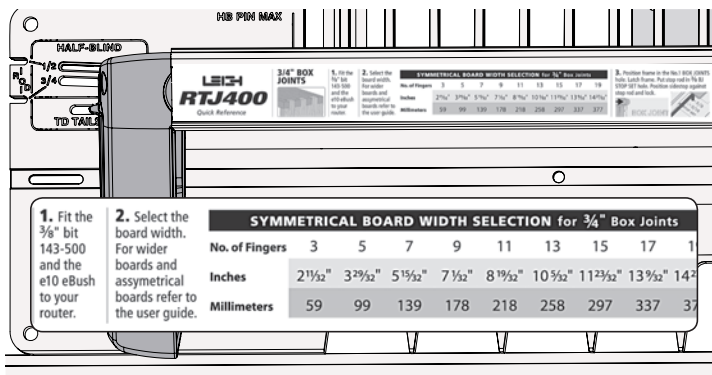

**11-4** Use the Quick Reference strip to determine the correct straight bit and eBush combination. **IMPORTANT NOTE:** Read the whole chapter before routing any boards, and see quick fit instructions, Step 11-15.

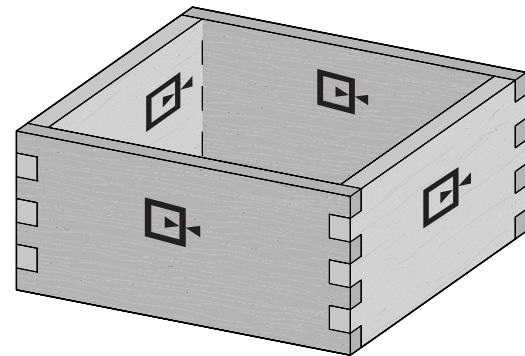

**11-5 Making a Box** Note the symbols indicating either side of the pin and socket boards can face in or out. With box joints, the same edge of the board goes against the side stop.

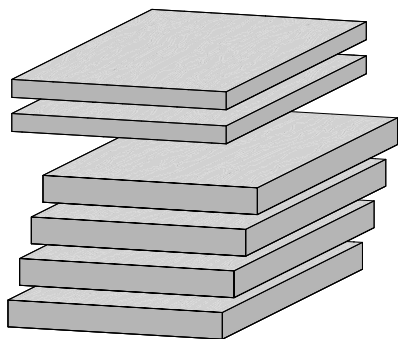

**11-6** Prepare four similar boards about 3/4" x 5 1/32" by about 12" long [19mm x 117mm x 305mm]. For the quick fit test you will need two test boards about 1/2" thick. Boards of different thicknesses may also be joined. **IMPORTANT: Read this whole chapter before routing any boards.**

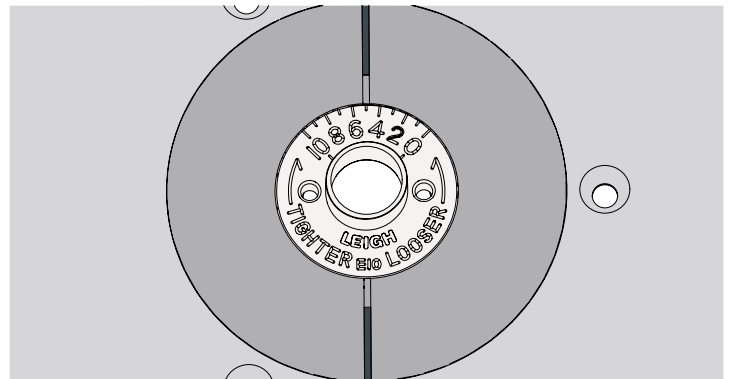

**11-7** Fit the e10 eBush to the router table insert ring, set to 5. Or if you have already done the quick fit test, use this setting instead.

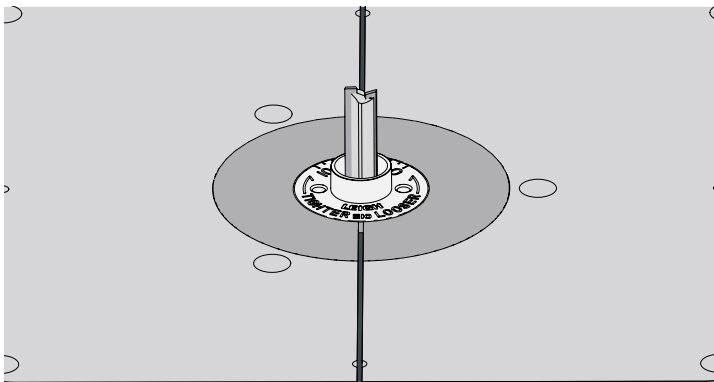

**11-8** With the router unplugged, install the supplied  $\frac{3}{8}$ " Leigh 143-500 bit. For cleaner routing use the optional  $\frac{3}{8}$ " Leigh 173-500 (HSS) or 173-500C (solid carbide) spiral upcut bit, available at leighjigs.com. **⚠** Make sure the bit spins freely before connecting the power.

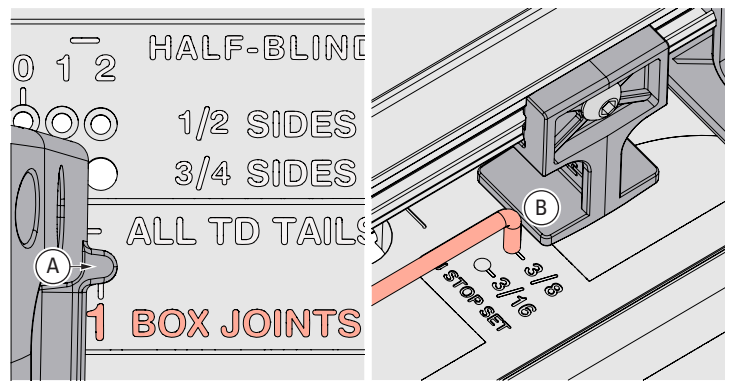

**11-9** Insert the right frame pin in the **No.1 BOX JOINTS** hole (A) and the left frame pin in the matching slot, then latch the frame. Put the short end of the stop rod into the **3/8" BJ STOP SET** hole. Slide the side stop to lightly touch the rod (B) and tighten the stop. Store the stop rod in the  $\frac{3}{4}$ " slot.

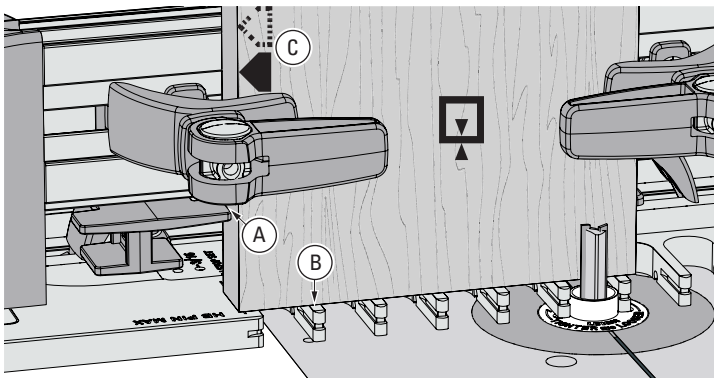

**11-10** Clamp socket board 1 flush on the template (B) with the side edge against the side stop (A). **Always keep the same side edge of the board to the side stop when routing box joints** (C). If board width is only slightly narrower than the chart width, center the board over the template, clamp in place and move side stop to touch the board.

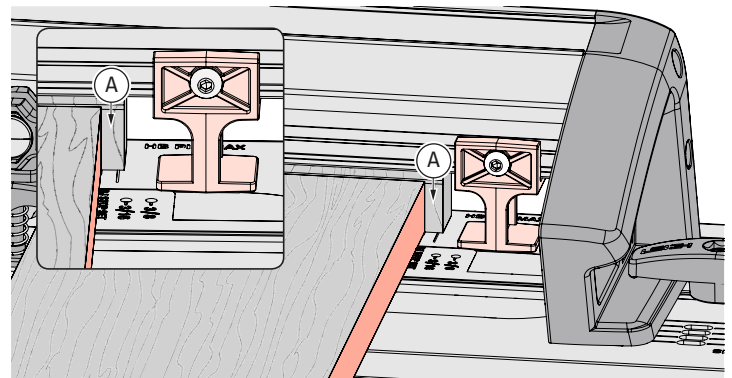

**11-11** Position a backer board  $\frac{1}{16}$ " [1.5mm] away from the edge of the socket board (A). This prevents the backer board from interfering with the side stop when the frame is repositioned in the second step. The backer board stays in place for the complete procedure. **Note: Clamp removed for clarity.**

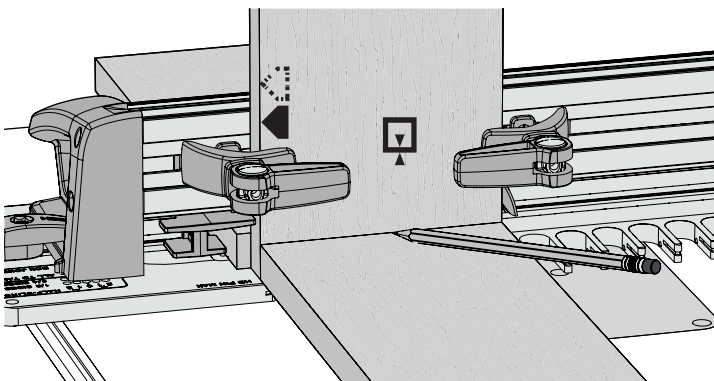

**11-12** Place the end of a pin board on the template and pencil a line on the tail board.

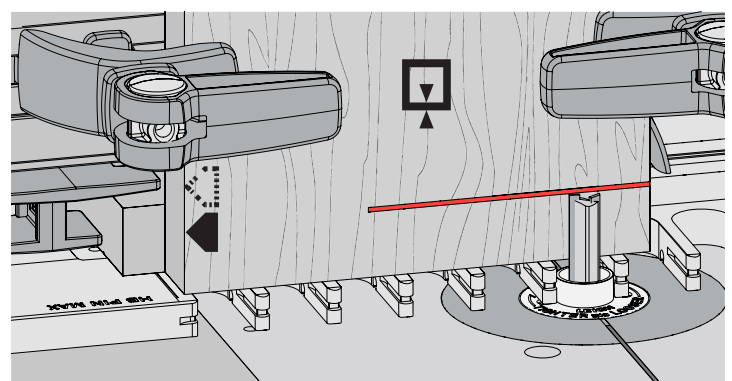

**11-13** Adjust the bit to the center of the line. **⚠** Double check that the bit still rotates freely. **IMPORTANT: Bit height determines the flushness of the joint, so set your bit properly the first time.** Adjustments for flushness are at the end of the chapter.

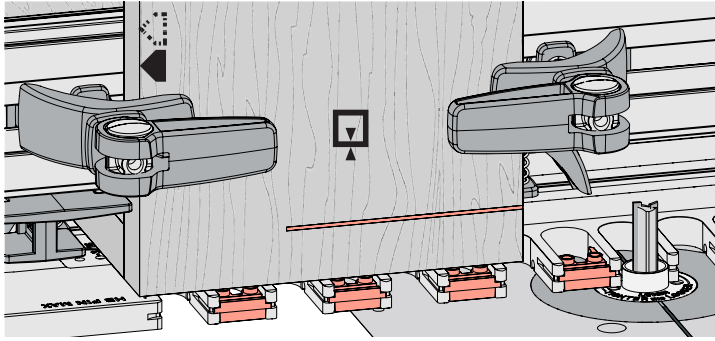

**11-14** This procedure requires routing into alternating template openings. To prevent routing the wrong sockets, insert the supplied blockers into each even numbered opening across the board width, plus one extra.

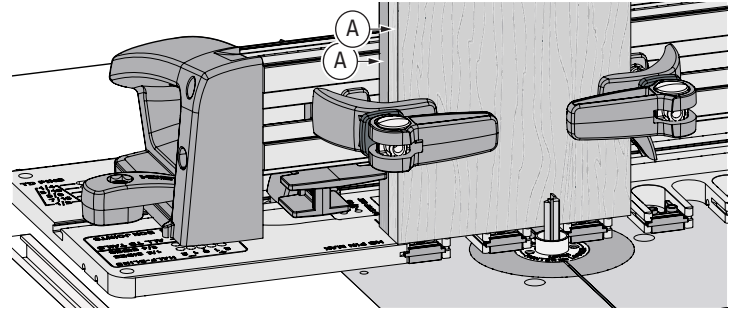

**11-15 Quick Fit Test** To save time and wood, clamp the two 1/2" thick **test** boards in the jig, back to back (A). **Review the remaining steps in this chapter.** Rout both boards at the same time and repeat again with frame in **No.2 BOX JOINTS** hole. Join the routed boards and make joint fit adjustments in the next three steps. Don't worry about board edge alignment, the test is for joint fit only.

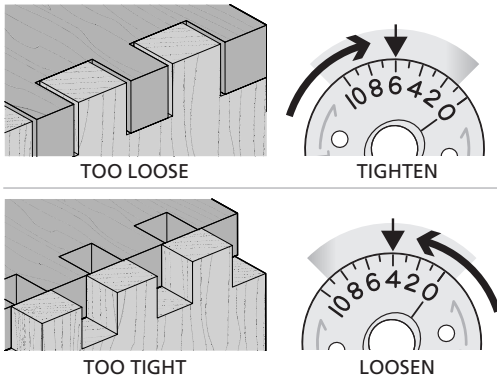

**11-16 Test for Fit** Keep the same side board edges together. If the joint is too loose, turn the eBush to a higher number, as shown in the next step. If too tight, turn the eBush to a lower number.

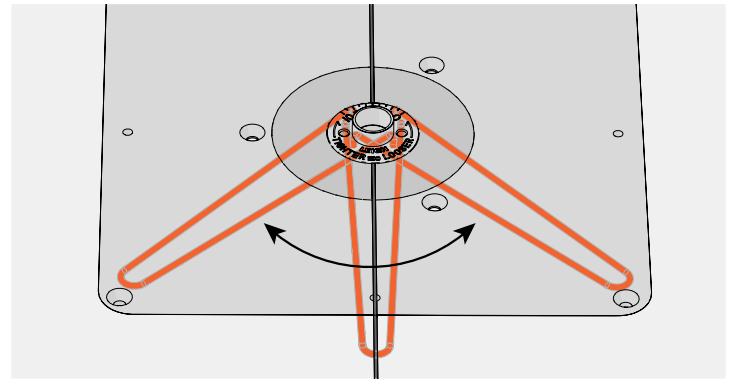

**11-17** Each increment on the eBush changes the joint glue line fit by 0.002" [0.05mm]. Half an increment, a mere 1000th inch! **Re-tighten the eBush nut after each guide bushing adjustment.**

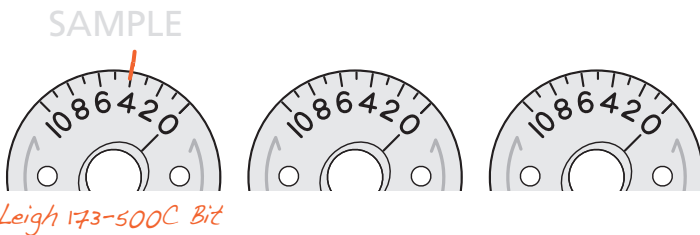

**11-18** Record your settings here.

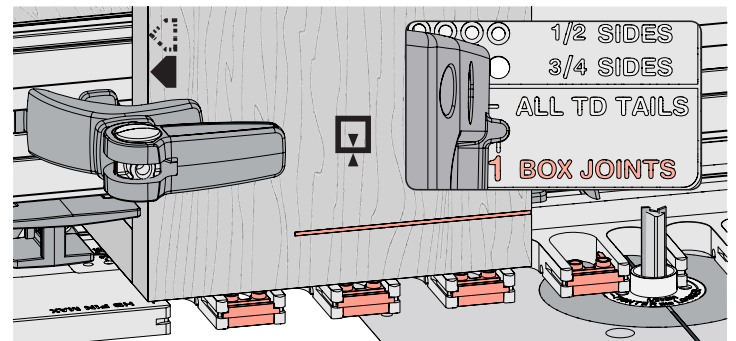

**11-19** Now that your joint tightness has been determined, re-clamp socket board 1 in the jig, move the frame pin to the **No.1 BOX JOINTS** hole and latch frame.



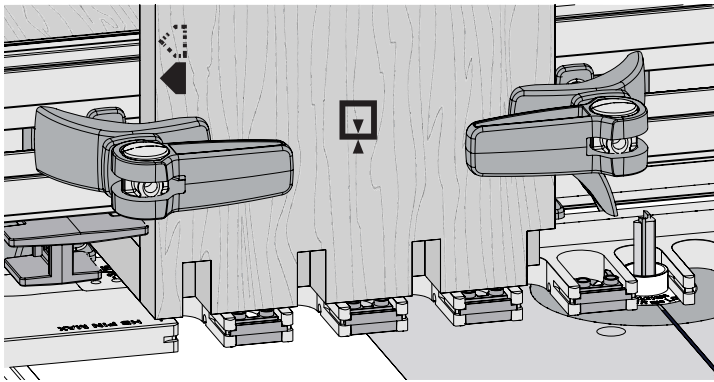

**11-20** Rout into the first opening and every other template opening i.e. 1, 3, 5 and 7. **⚠ The eBush must touch one side of the opening as you enter and the other side as you exit. Do not remove the board or the backer board.**

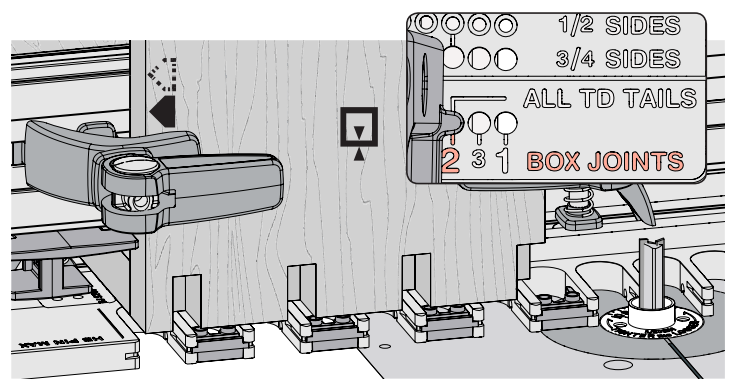

**11-21** Loosen the latches and move the frame pin to the **No.2 BOX JOINTS** hole and latch the frame.

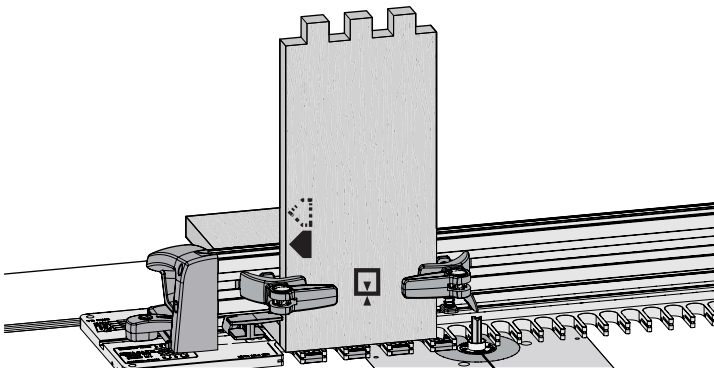

**11-22** Again, carefully rout into the same sockets as before, i.e. 1, 3, 5, 7. Unclamp and flip the board, keeping the same edge against the side stop. Clamp the board and repeat the steps in reverse order. Remove socket board 1 and repeat steps 11-19 through 11-22 for socket board 2. Remove socket board 2.

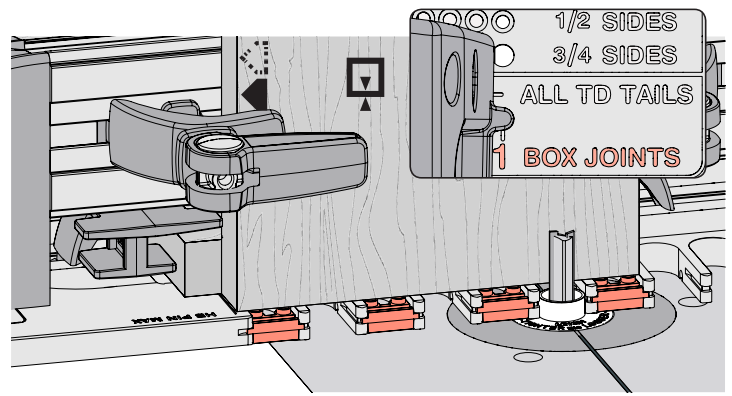

**11-23** **Leave the frame latched and the backer board in place.** The right frame pin should be in the **No.1 BOX JOINTS** hole. Move the blockers to the odd numbered sockets. Clamp pin board 1 against the side stop.

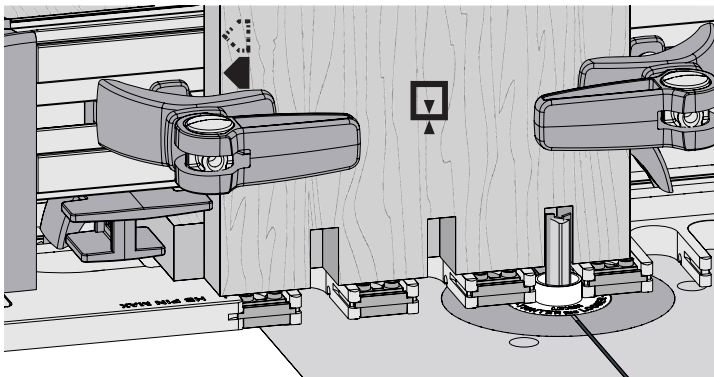

**11-24** Now rout into the second and every alternating even numbered openings, i.e. 2, 4, 6, etc. **Do not remove the board, backer board or the blockers.**

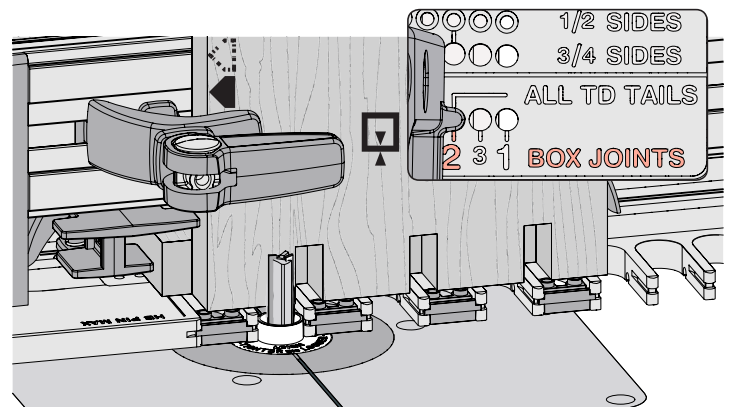

**11-25** Move the frame pin to the **No.2 BOX JOINTS** hole and latch the frame. Rout into the same, even numbered sockets i.e. 2, 4, 6, etc. Unclamp and flip the board. Clamp the board and repeat the steps in reverse order. Repeat steps 11-23 through 11-25 with the second pin board. Remove socket board 2. All four boards are now complete and ready for assembly.

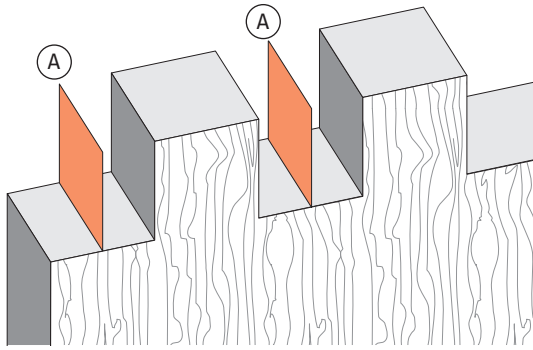

**11-26** Theoretically, there will be nothing left in the sockets, where the bit has passed by twice. However, routing tolerances can leave a very thin “wall” **A**. This can be quickly removed with a chisel, file, or knife.

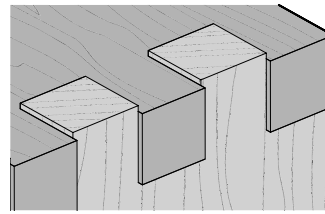

OVER FLUSH

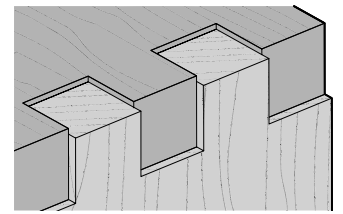

UNDER FLUSH

**11-27** If the joint is over flush, lower the bit to suit. If the joint is under flush, raise the bit to suit. Rout a fresh test joint until fit and flushness are perfect before routing the actual workpieces. ■

## RTJ400 OPERATION

## CHAPTER 12

## 3/16" Box (Finger) Joints

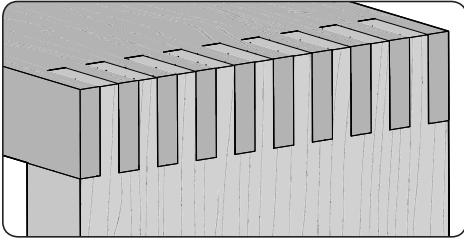
**IMPORTANT SAFETY NOTE**

Before using your Leigh RTJ400 you must have completed the preparatory steps listed in the previous pages, including reading the jig safety recommendations in Chapter 3.

**12-1 Getting Started**

Review the drawing below. **Symmetrical** joints have pins (A) on both edges of one board, and sockets (B) on both edges of the mating board. **Asymmetrical** joints have a pin (C) on one edge and a socket (D) on the other edge of each board.

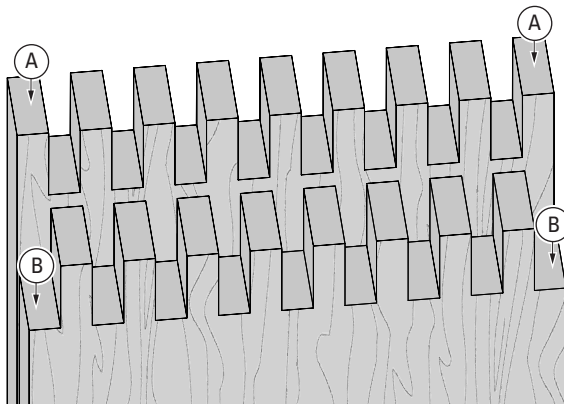

SYMMETRICAL

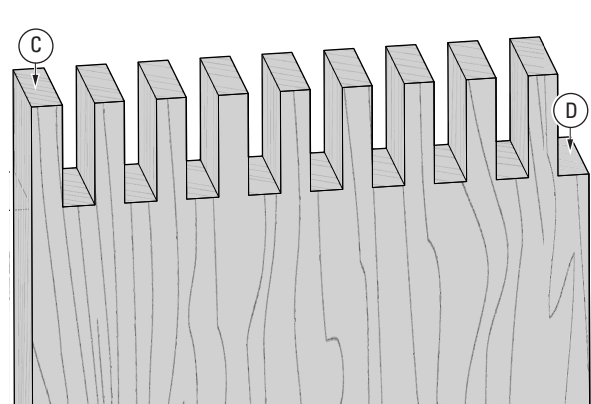

ASYMMETRICAL

**12-2 Bits, Guide Bushing and Stop Rod**

3/16" box joints are routed with the optional 3/16" Leigh straight bit 166 or 166C, the e10 guide bushing (eBush), and the stop rod (for positioning the side stop only). They can be routed in board thicknesses up to the maximum cutting depth of the bit, in this case, 5/8" [15.9mm].

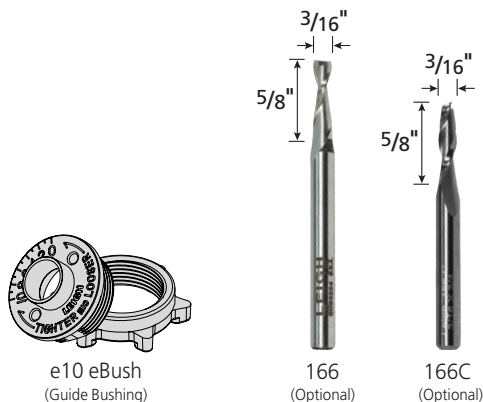

Stop Rod  
(For positioning side stop)

e10 eBush  
(Guide Bushing)

166  
(Optional)

166C  
(Optional)

**BOX JOINT BIT CUTTING DEPTH**

<b>Bit Diameter</b>	3/16"
<b>Item No. (HSS)</b>	<b>166</b>
<b>Item No. (Solid Carbide)</b>	<b>166C</b>
<b>Depth of Cut</b>	0"-----
	1/8"-----
	1/4"-----
	3/8"-----
	1/2"-----
	5/8"-----
	3/4"-----
	7/8"-----
	1"-----

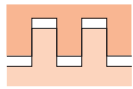

**Symmetrical Joints** have a full pin at each board edge. The total number of pins and sockets will always be an odd number.

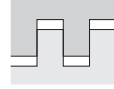

**Asymmetrical Joints** have a full pin at one edge and a full socket at the other. The total number of pins and sockets will always be an even number.

### Symmetrical Board Width Chart for 3/16" Box Joints

Total Pins & Sockets	3	5	7	9	11	13	15	17	19	21	23	25	27	29	31	33	35	37	39	41
Inches	3/16"	3/32"	1 1/32"	1 3/4"	2 1/8"	2 17/32"	2 29/32"	3 3/16"	3 11/16"	4 3/32"	4 15/32"	4 7/8"	5 1/4"	5 21/32"	6 1/32"	6 7/16"	6 13/16"	7 7/32"	7 19/32"	8"
Millimeters	14	25	34	44	54	64	74	84	94	104	114	124	133	144	153	164	173	183	193	203

### Asymmetrical Board Width Chart for 3/16" Box Joints

Total Pins & Sockets	4	6	8	10	12	14	16	18	20	22	24	26	28	30	32	34	36	38	40
Inches	2 5/32"	1 7/32"	1 9/16"	1 15/16"	2 11/32"	2 23/32"	3 1/8"	3 1/2"	3 29/32"	4 9/32"	4 11/16"	5 1/8"	5 15/32"	5 27/32"	6 1/4"	6 5/8"	7 1/32"	7 13/32"	7 13/16"
Millimeters	20	29	40	49	60	69	79	89	99	109	119	129	139	148	159	168	179	188	198

**12-3** Board widths are determined by the total number of pins and sockets in the joint design and whether the joint is symmetrical or asymmetrical. Use this chart to determine board widths up to 8" [203mm] for 3/16" joints. For wider boards, see [www.leighjigs.com](http://www.leighjigs.com).

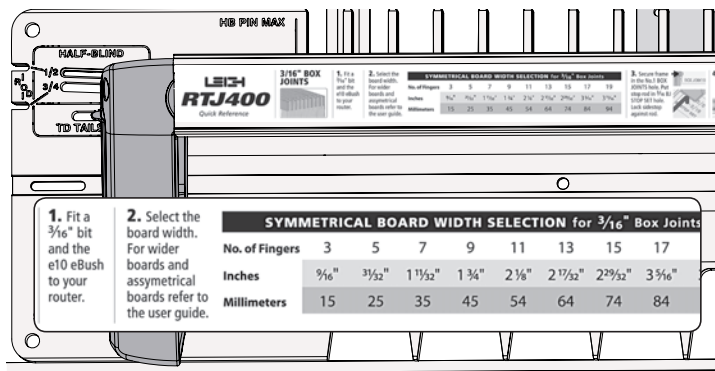

**12-4** Use the Quick Reference strip to determine the correct straight bit and eBush combination. **IMPORTANT NOTE:** Read the whole chapter before routing any boards, and see quick fit instructions in 12-14.

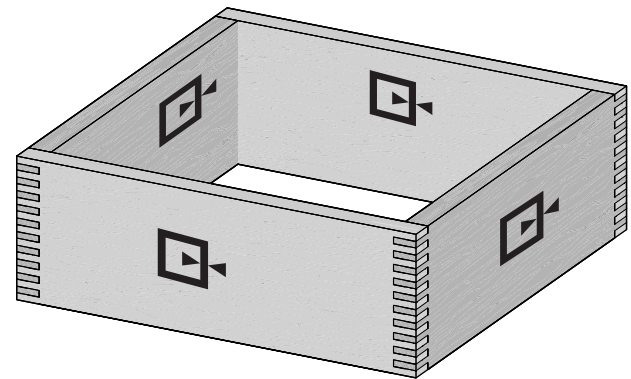

**12-5 Making a Box** Note the symbols indicating either side of the pin and socket boards can face in or out. With box joints, the same edge of the board goes against the side stop.

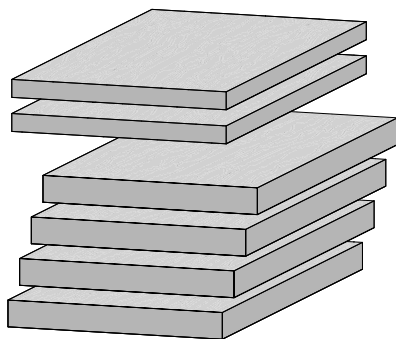

**12-6** Prepare four similar boards 5/8" x 4 5/8" by about 8" long [19mm x 115mm x 200mm]. For the quick fit test you'll need two test boards about 1/4" thick. Boards of different thicknesses may also be joined. **IMPORTANT: Read this whole chapter before routing any boards.**

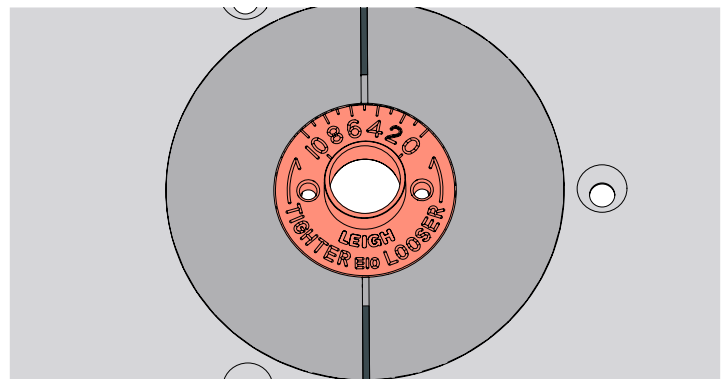

**12-7** Fit the e10 eBush to the router table insert ring set to 5, or if you have already done the quick fit test, use this setting instead.

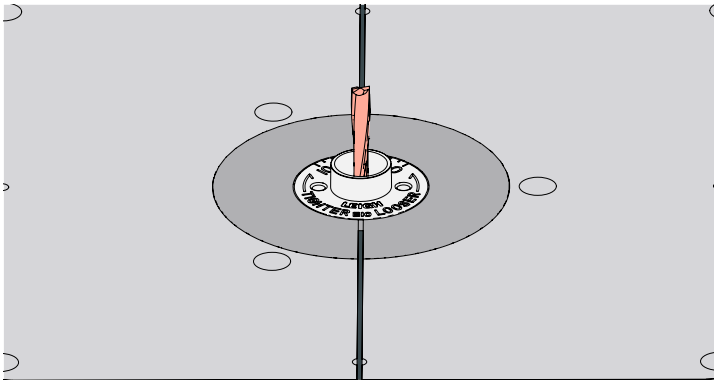

**12-8** With the power disconnected from the router, install the optional 3/16" Leigh 166 (HSS) or 166C (solid carbide) bit. Make sure the bit spins freely in the bushing before reconnecting the power. Optional bits available at leighjigs.com

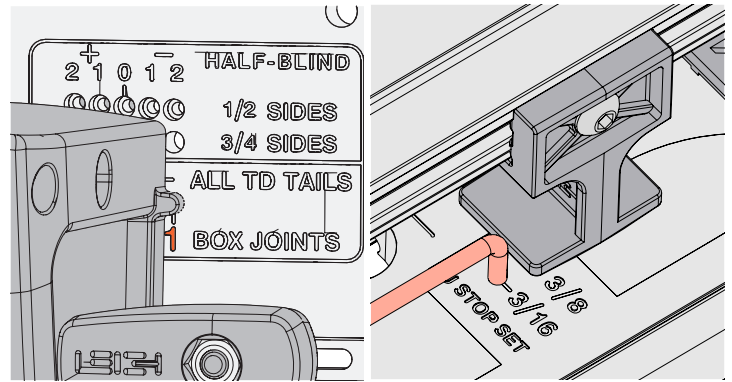

**12-9** Insert the right frame pin in the **No.1 hole, BOX JOINTS** mode and the left frame pin in the **TD TAILS & BJ slot**. Latch the frame. Put the short end of the stop rod into the **3/16" BJ STOP SET** hole. Slide the side stop to lightly touch the rod and tighten the side stop. Store the stop rod in the 3/4" slot.

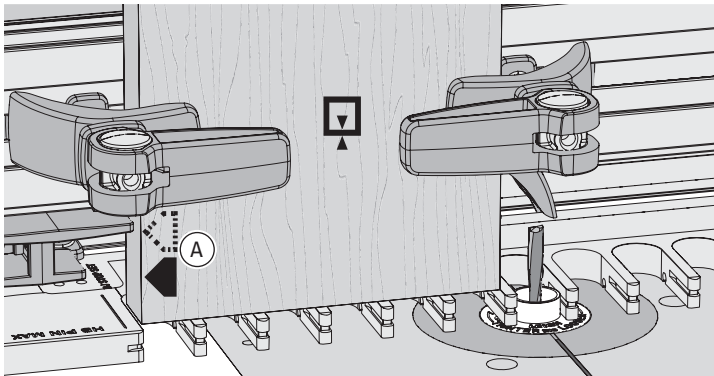

**12-10** Clamp pin board 1 vertically with the side edge against the side stop, the end edge flush on the template. **Always keep the same side edge of the board to the side stop when routing box joints** (A).

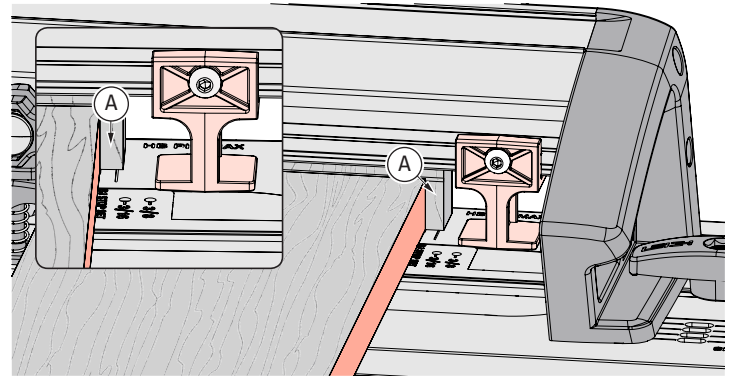

**12-11** Position a backer board at least 3/16" [4.5mm] from the board edge (A). This prevents the backer board from interfering with the side stop when the frame is repositioned in the following steps. The backer board stays in place for the complete procedure. **Note: Clamp removed for clarity.**

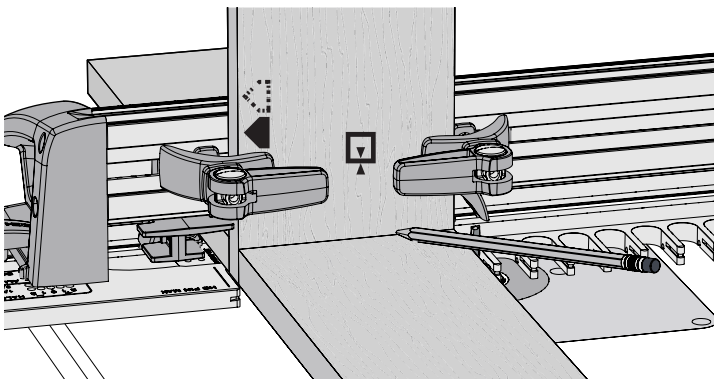

**12-12** Place the end of a socket board on the template and pencil a line on the pin board.

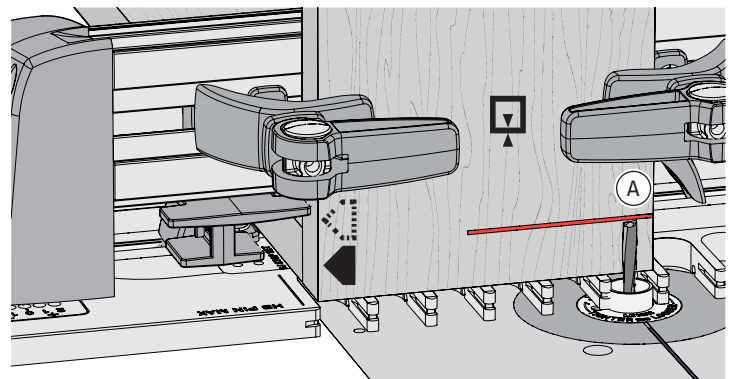

**12-13** Adjust the bit until the tip is level with the center of the pencil line on board 1 (A). **IMPORTANT: Bit height determines the flushness of the joint, so set your bit properly the first time.** Adjustments for flushness if required are at the end of the chapter. **⚠** Double check that the bit still rotates freely.

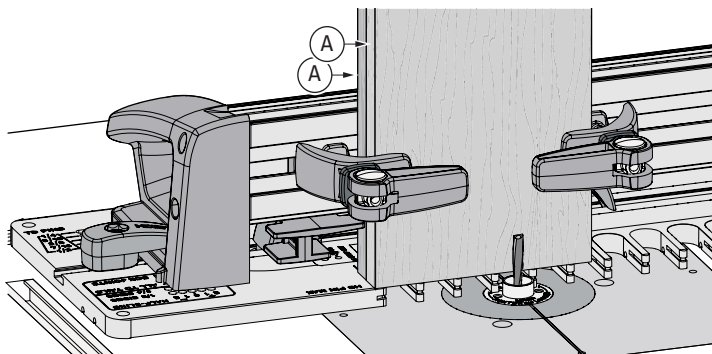

**12-14 Quick Fit Test** To save time and wood, clamp the two ¼" thick scrap **test** boards in the jig, back to back **A**. **⚠️ Review the remaining steps in this chapter.** Rout both boards at the same time. Repeat again with the frame in the **No.2 hole, BOX JOINTS** mode. Join the routed boards and make joint fit adjustments in the next steps. Don't worry about board edge alignment, the test is for joint fit only.

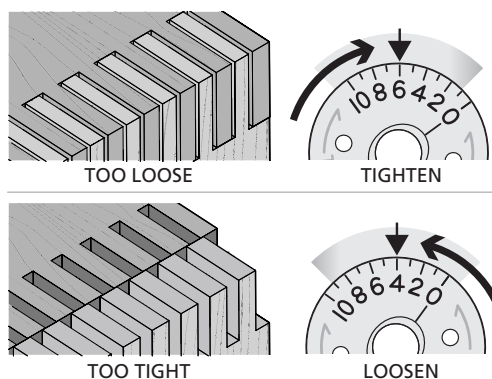

**12-15 Joint Fit Adjustment** Keep the same side board edges together. If the joint is too loose, turn the eBush to a higher number, as shown in the next step. If too tight, turn the eBush to a lower number.

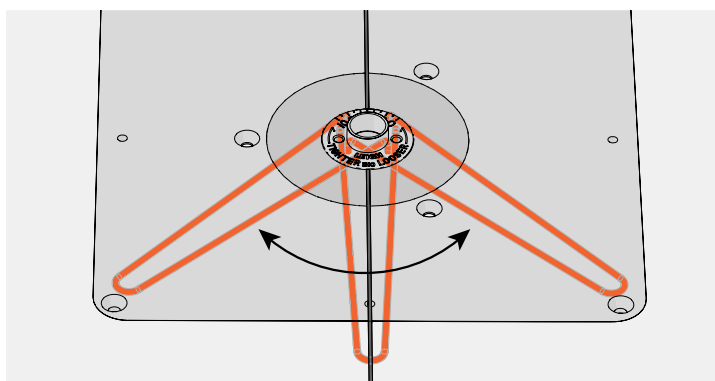

**12-16** Each increment on the eBush changes the joint glue line fit by 0.002" [0.05mm]. Half an increment, a mere 1000th inch! **Re-tighten the eBush nut after each guide bushing adjustment.** If necessary rout further test boards until correct joint fit is achieved, repeating Steps 12-14 through 12-16.

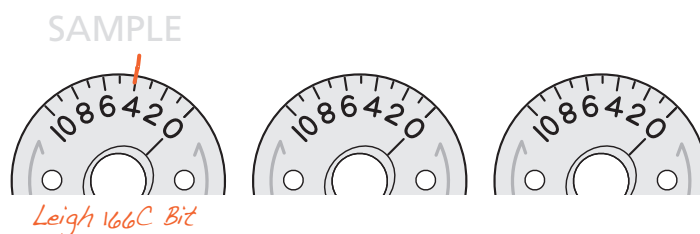

**12-17** On the eBushes above, record the settings you used to achieve perfect joint fit. The first eBush is an example of how to record your setting.

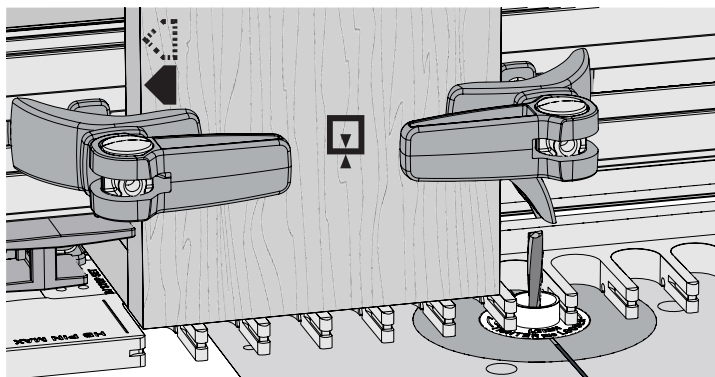

**12-18** Now that your joint tightness has been determined, re-clamp pin board 1 with the side edge against the side stop, the end edge flush on the template.

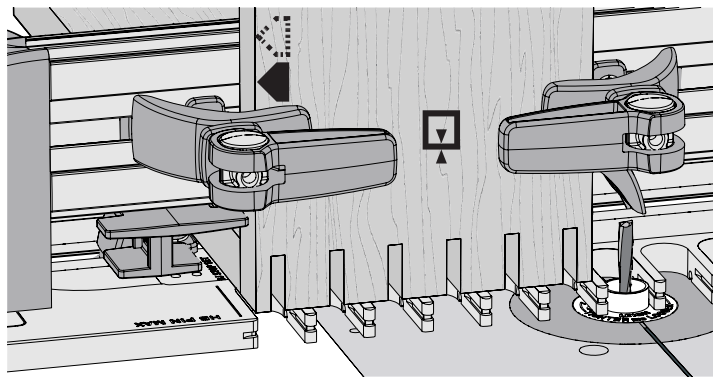

**12-19** Rout into every opening. **⚠️ The eBush must touch one side of the opening as you enter and the other side as you exit. Do not remove the routed board or the backer board.**

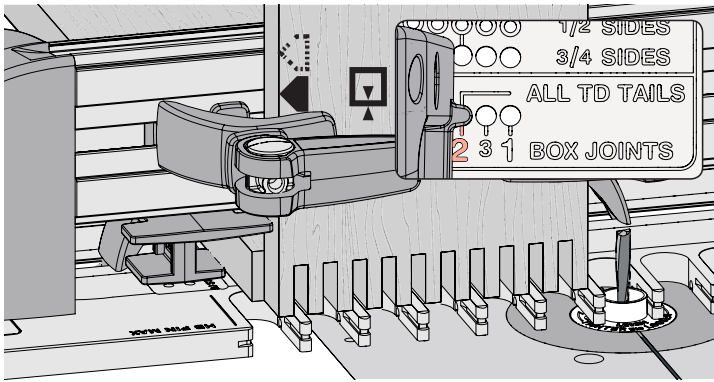

**12-20** Unlatch and move the right frame pin to the **No.2 hole, BOX JOINTS** mode, latch the frame. Rout into every opening. Unclamp and flip the board, keeping the same side against the side stop. Clamp it and repeat the steps in reverse order. Remove pin board 1 and repeat steps 12-19 and 12-20 for pin board 2.

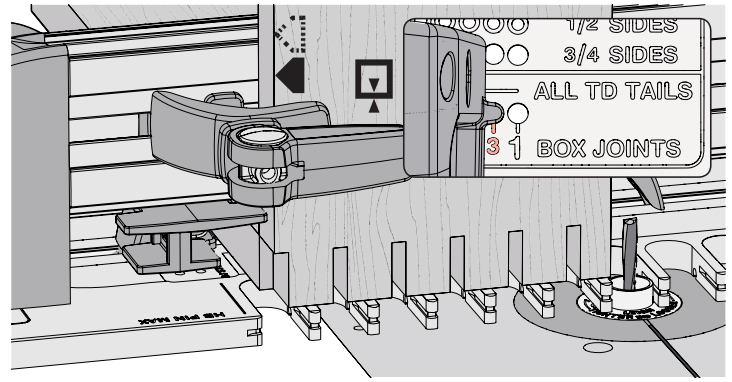

**12-21** Remove pin board 2. Unlatch and move the frame pin to the **No.3 hole, BOX JOINTS** mode and latch the frame. Clamp a socket board against the side stop and rout into all template openings.

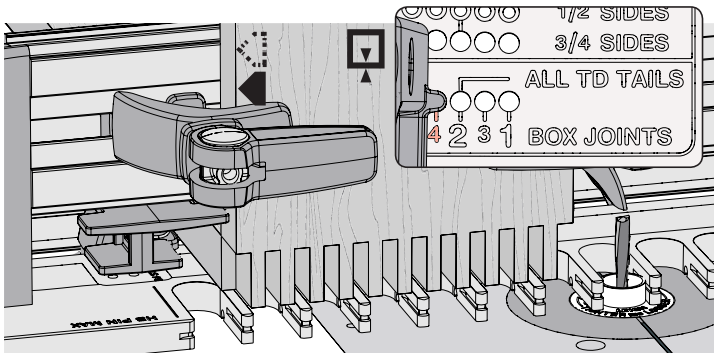

**12-22** Unlatch and move the frame pin to the **No.4 hole, BOX JOINTS** mode and latch the frame. Again, rout into all openings. Unclamp and flip the board, keeping the same edge against the side stop. Clamp it and repeat the routing in reverse order. Remove socket board 1 and repeat steps 12-21 and 12-22 for socket board 2. Remove socket board 2. All four boards are now complete and ready for assembly.

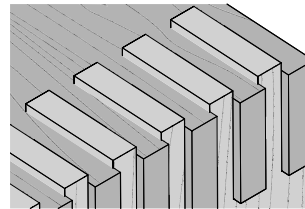

OVER FLUSH

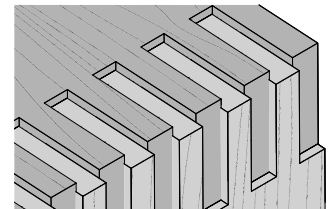

UNDER FLUSH

**12-23 Flushness** If the joint is **over flush**, lower the bit to suit. If the joint is **under flush**, raise the bit to suit. ■





## RTJ400 OPERATION

## CHAPTER 13

## 3/32" Box (Finger) Joints

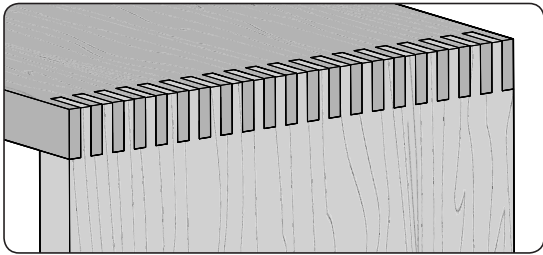
**IMPORTANT SAFETY NOTE**

Before using your Leigh RTJ400 you must have completed the preparatory steps listed in the previous pages, including reading the jig safety recommendations in Chapter 3.

**13-1 Getting Started**

Review the drawing below. **Symmetrical** joints have pins (A) on both edges of one board, and sockets (B) on both edges of the mating board. **Asymmetrical** joints have a pin (C) on one edge and a socket (D) on the other edge of each board.

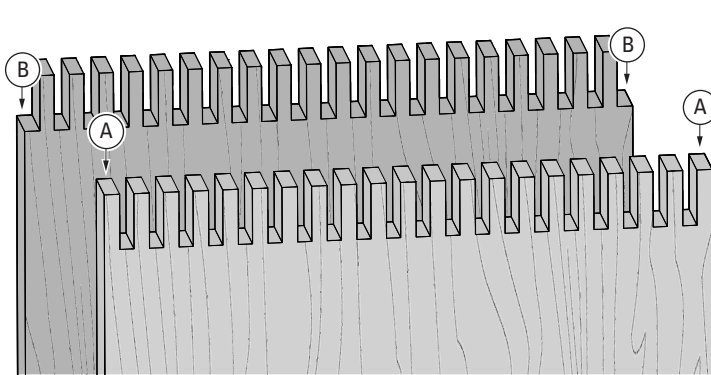

SYMMETRICAL

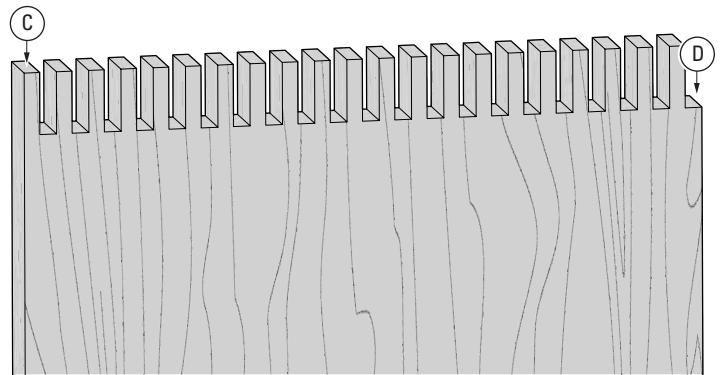

ASYMMETRICAL

**13-2 Bit, Guide Bushing and Blocker**

3/32" box joints are routed with the optional 3/32" straight bit 163, the e10 guide bushing (eBush) and a blocker. They can be routed in board thicknesses up to the maximum cutting depth of the bit, in this case, 3/8" [9.5mm].

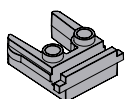

Blocker

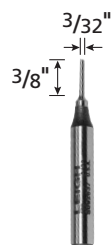
e10 eBush  
(Guide Bushing)163  
(Optional)

BOX JOINT BIT CUTTING DEPTH	
Bit Diameter	3/32"
Item No. HSS (Optional)	163
Item No. Solid Carbide	-
Depth of Cut	0" - 1/8"
	1/4" - 3/8"
	1/2" - 5/8"
	3/4" - 7/8"
	1"
	1"

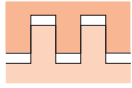

**Symmetrical Joints** have a full pin at each board edge. The total number of pins and sockets will always be an odd number.

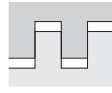

**Asymmetrical Joints** have a full pin at one edge and a full socket at the other. The total number of pins and sockets will always be an even number.

**Symmetrical Board Width Chart for 3/32" Box Joints**

Total Pins & Sockets	3	5	7	9	11	13	15	17	19	21	23	25	27	29	31	33	35	37	39	41
Inches	9/32"	15/32"	1/16"	7/8"	1 1/16"	1 1/4"	1 1/8"	1 21/32"	1 27/32"	2 1/32"	2 1/4"	2 7/16"	2 5/8"	2 13/16"	3 1/32"	3 7/32"	3 13/32"	3 19/32"	3 11/16"	4
Millimeters	7	12	17	22	27	32	37	42	47	52	57	62	67	71	77	82	87	91	97	102

**Asymmetrical Board Width Chart for 3/32" Box Joints**

Total Pins & Sockets	4	6	8	10	12	14	16	18	20	22	24	26	28	30	32	34	36	38	40
Inches	3/8"	9/16"	25/32"	31/32"	1 1/32"	1 1/8"	1 9/16"	1 3/4"	1 19/16"	2 1/8"	2 11/32"	2 17/32"	2 23/32"	2 29/32"	3 1/8"	3 5/16"	3 1/2"	3 11/16"	3 29/32"
Millimeters	10	15	20	25	29	34	40	44	49	54	60	64	69	74	79	84	89	94	99

**13-3** Board widths are determined by the total number of pins and sockets in the joint design and whether the joint is symmetrical or asymmetrical. Use this chart to determine board widths up to 4" [102mm] for 3/32" joints. For wider boards, see [www.leighjigs.com](http://www.leighjigs.com).

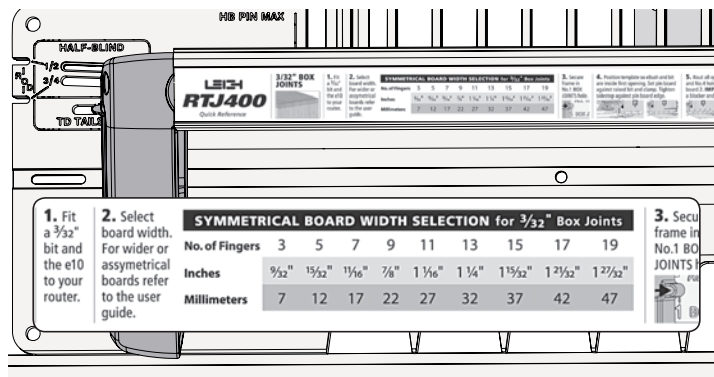

**13-4** Use the Quick Reference strip to determine the correct straight bit and eBush combination. **IMPORTANT NOTE:** Read the whole chapter before routing any boards, and see quick fit instructions in 13-15.

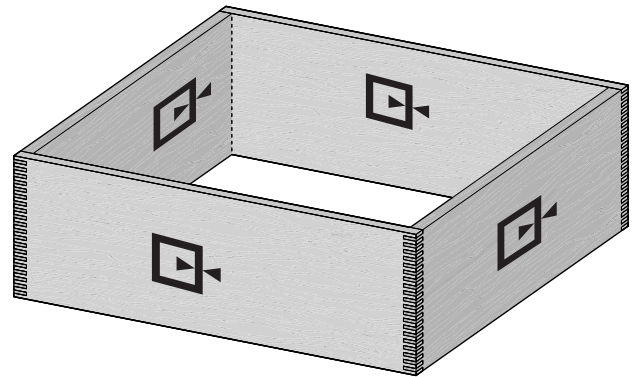

**13-5 Making a Box** Note the symbols indicating either side of the pin and socket boards can face in or out. With box joints, the same edge of the board goes against the side stop.

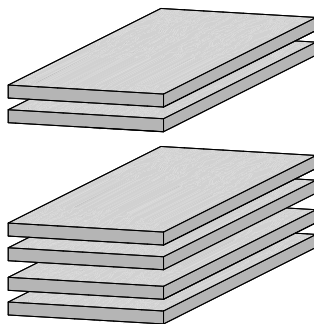

**13-6** Prepare four similar boards 1/4" x 4 5/8" by about 8" long [10mm x 115mm x 200mm]. For the quick fit test you will need two test boards about 1/4" or 3/16" thick. Boards of different thicknesses may also be joined. **IMPORTANT: Read this whole chapter before routing any boards.**

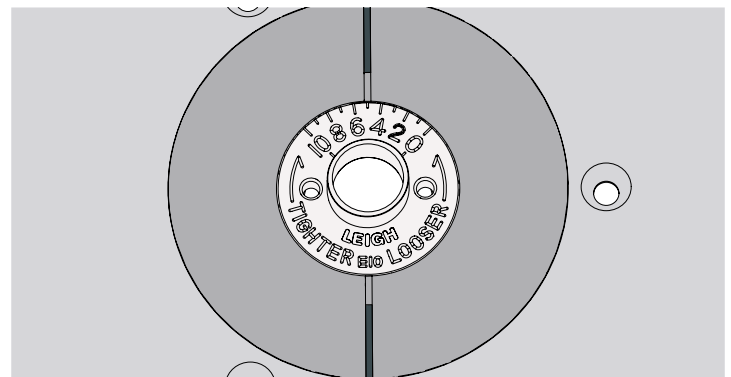

**13-7** Fit the e10 eBush to the router table insert ring, set to 5.

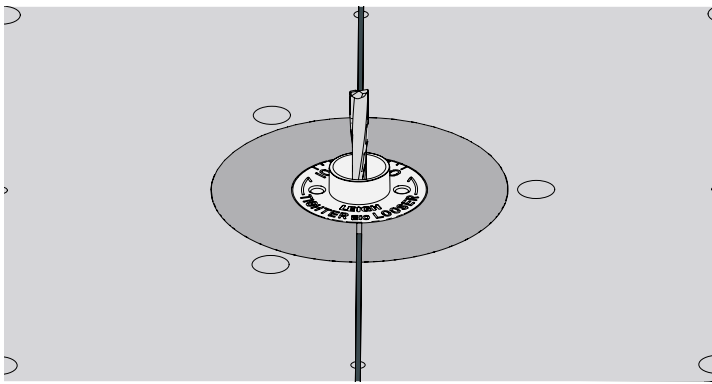

**13-8** With the power disconnected from the router, install the optional 3/32" Leigh 163 bit. **⚠** Make sure the bit spins freely within the bushing before reconnecting the power.

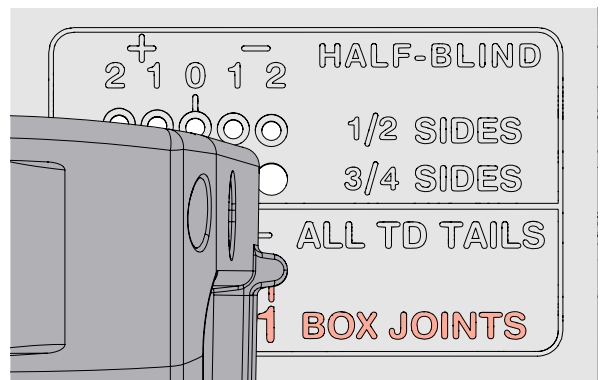

**13-9** Insert the right frame pin in the **No.1 hole, BOX JOINTS** mode and the left frame pin in the **TD TAILS & BJ slot** and latch the frame.

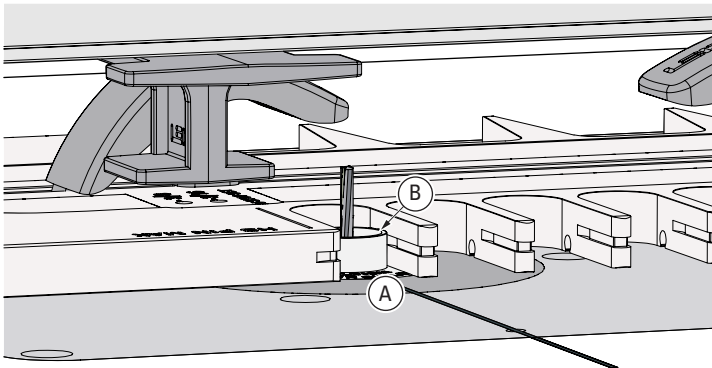

**13-10** Raise the bit above the template and move the template, putting the eBush in the first template opening **A** with the inner edge of the opening **B** touching the bushing.

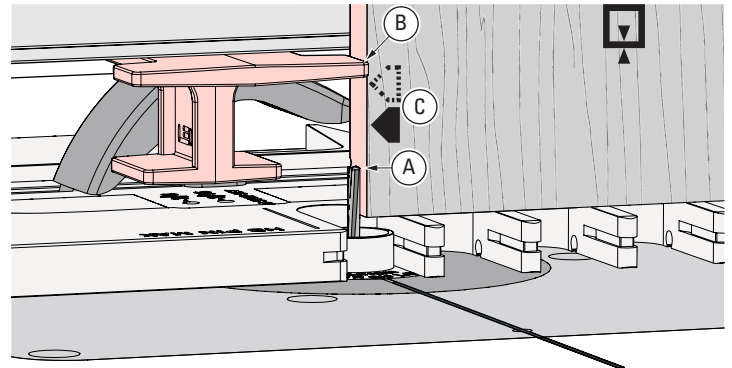

**13-11** Set pin board 1 on the template, touching the 3/32" bit **A**. Clamp in place. Move the side stop to touch the board edge **B** and tighten it. **The 3/32" box joint requires moving the template from right to left in four steps. Always keep the same side edge of the board to the side stop when routing box joints C.**

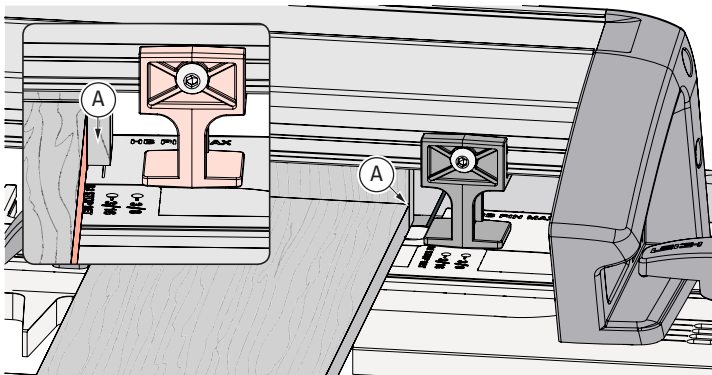

**13-12** Position a backer board at least 3/16" [4.5mm] from the board edge **A**. This prevents the backer board from interfering with the side stop when the frame is repositioned in subsequent steps. The backer board stays in place for the complete procedure.  
**Note: Clamp removed for clarity.**

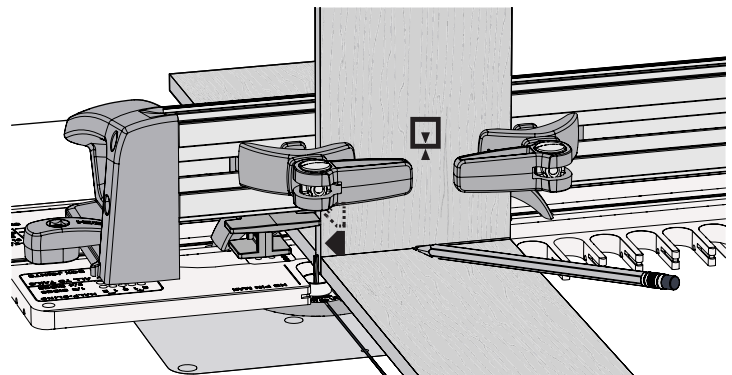

**13-13** Place the end of a socket board on the template and pencil a line on the pin board.

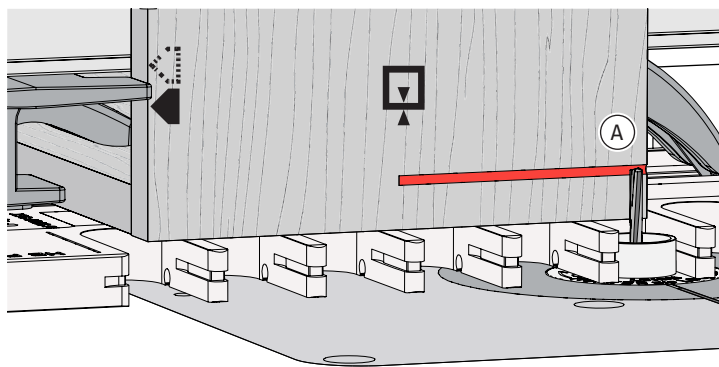

**13-14** Adjust the bit until the tip is level with the center of the pencil line on pin board 1 (A). ⚠ Double check that the bit still rotates freely. **IMPORTANT: Bit height determines the flushness of the joint, so set your bit properly the first time.** Adjustments for flushness are at the end of the chapter.

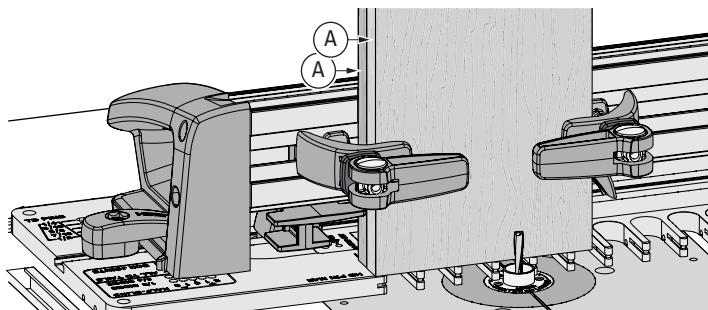

**13-15 Quick Fit Test** To save time and wood, clamp the two approx.  $\frac{3}{16}$ " thick scrap **test** boards in the jig, back to back (A). ⚠ **Review the remaining steps in this Chapter.** Rout both boards in all four frame pin positions 1, 3, 2 and 4. Join the routed boards and make the joint fit adjustments in the next three steps. Don't worry about board edge alignment, the test is for joint fit only.

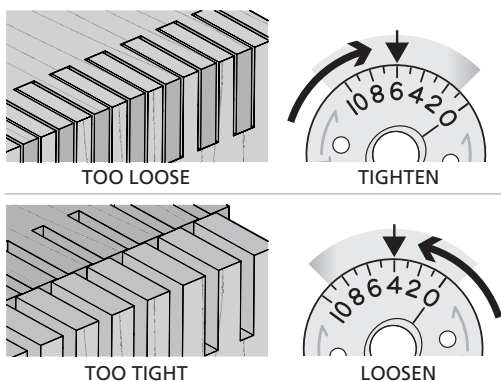

**13-16 Joint Fit Adjustment** Join the boards, keeping the same side board edges together. If the joint is too loose, turn the eBush to a higher number, as shown in the next step. If too tight, turn the eBush to a lower number.

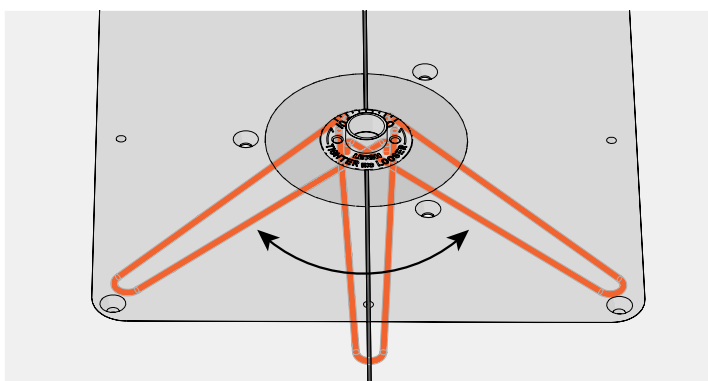

**13-17** Each increment on the eBush changes the joint glue line fit by 0.002" [0.05mm]. Half an increment, a mere 1000th inch! **Re-tighten the eBush nut after each guide bushing adjustment.**

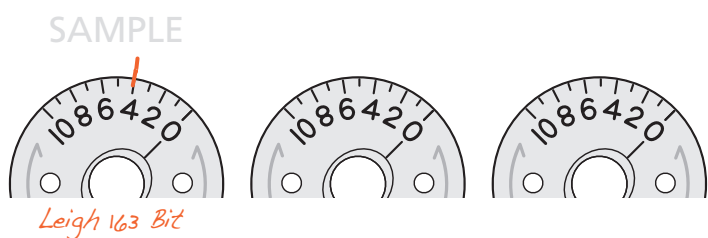

**13-18** On the eBushes above, record the settings you used to achieve perfect joint fit. The first eBush is an example of how to record your setting.

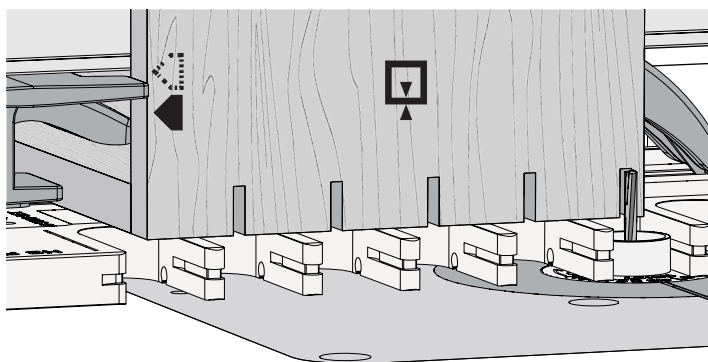

**13-19** Now that your joint tightness has been determined, with the frame pin in position 1, re-clamp pin board 1. Rout in and out of each template opening. ⚠ The eBush must touch one side of the opening as you enter and the other side as you exit.

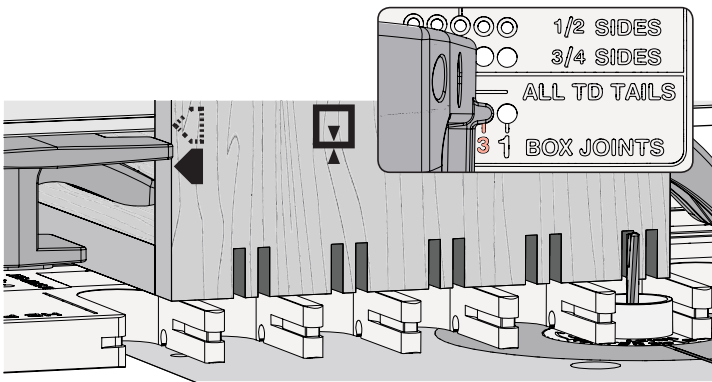

**13-20 Leave the board in place.** Unlatch the frame and move the right frame pin to position 3. Rout in every template opening.

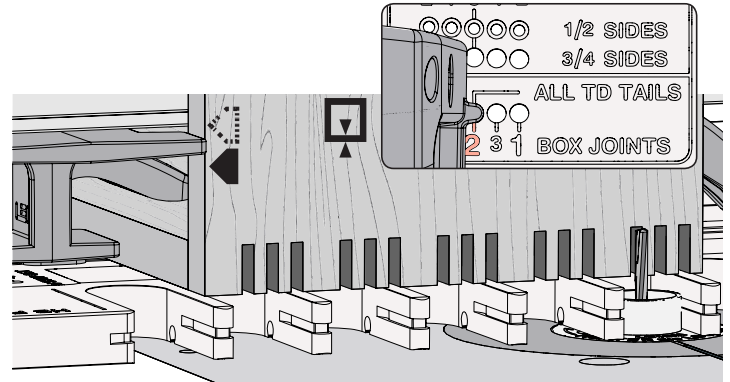

**13-21 Leave the board in place.** Unlatch the frame and move the right frame pin to position 2. Rout in all openings.

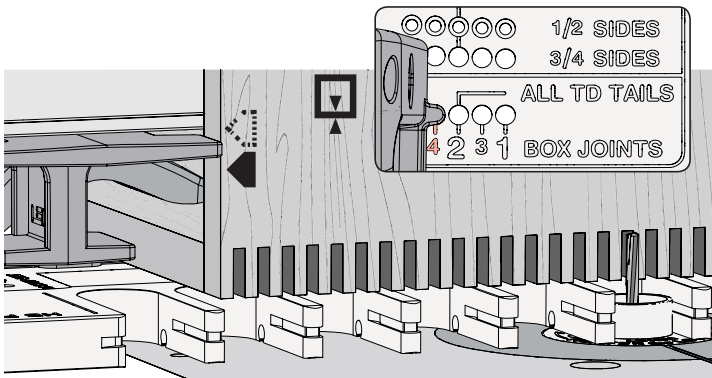

**13-22 Leave the board in place.** Unlatch the frame and move the right frame pin to position 4. Rout in every template opening. Unclamp and flip the board, keeping the same edge against the side stop. Clamp the board. Repeat the steps in reverse order. Remove pin board 1. Repeat procedure for pin board 2.

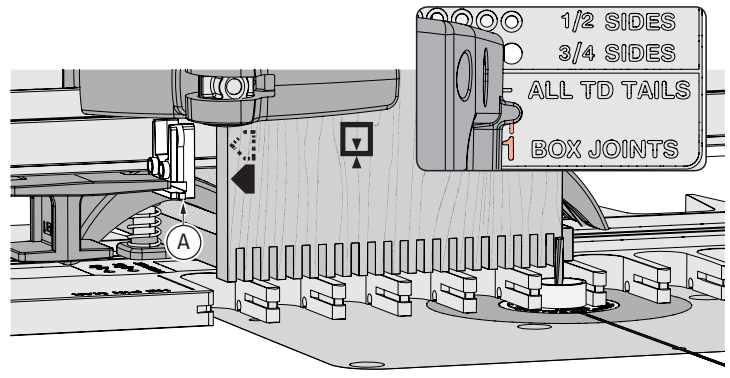

**13-23 Leave pin board 2 in place and do not unlatch the frame.** Loosen the side stop and move it away from the board. **Note: The right frame pin should already be in position 1.** Attach one of the blockers to the side stop. Make sure the blocker is seated firmly against the side stop (A).

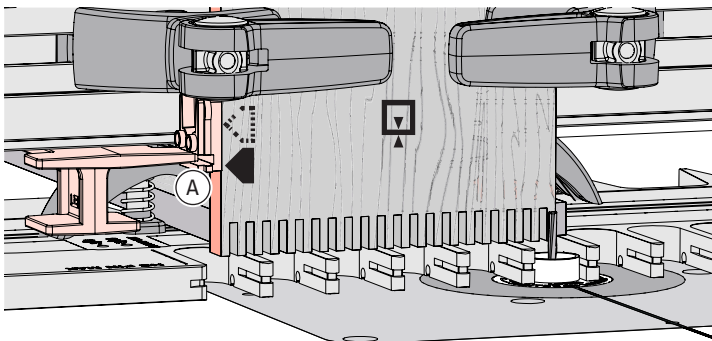

**13-24 Leave the board in place.** Move the side stop, with the blocker attached, against the board and tighten it (A).

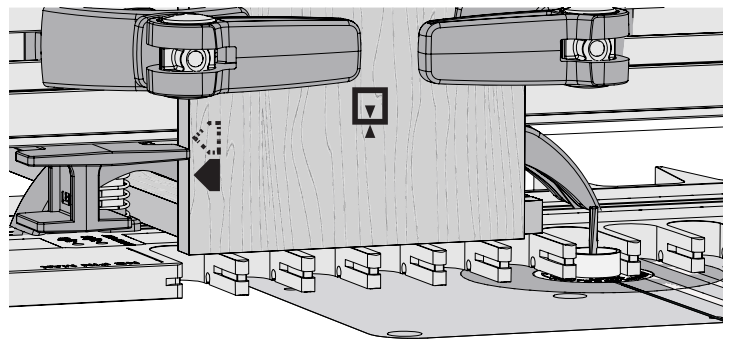

**13-25 Remove the routed pin board and the blocker.** Clamp socket board 1 against the repositioned side stop with its bottom edge flush on the template.

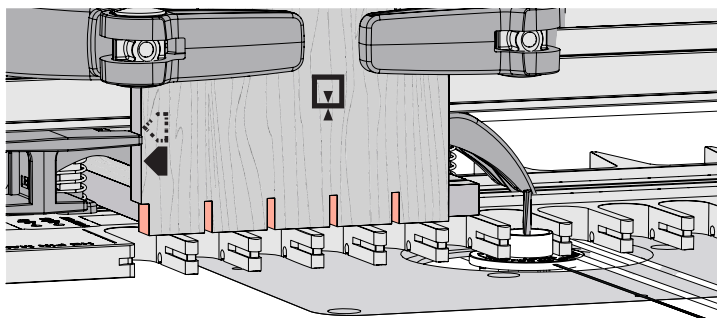

**13-26** Rout in and out of each template opening.

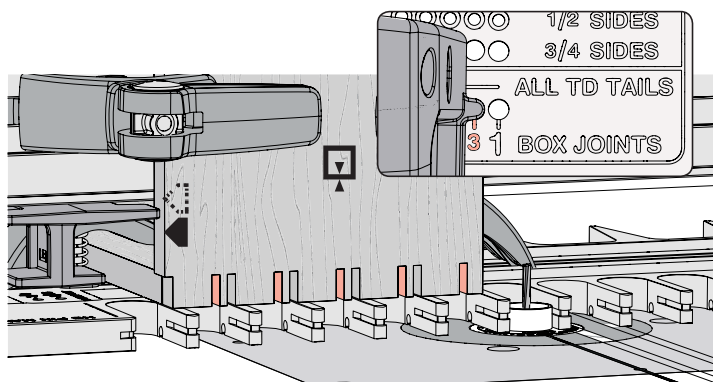

**13-27** Leave the board in place. Unlatch the frame and move the right frame pin to position 3. Rout in every template opening.

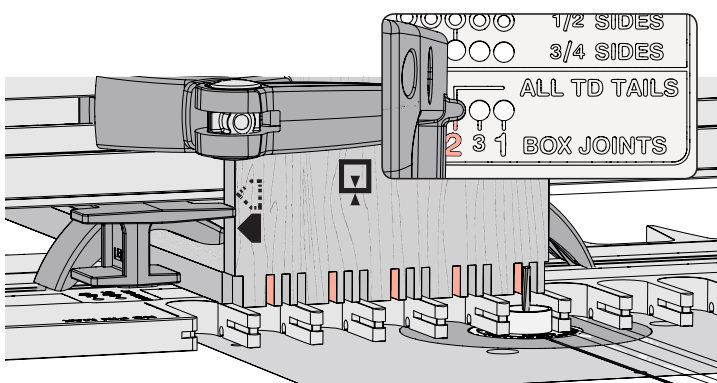

**13-28** Leave the board in place. Unlatch the frame and move the right frame pin to position 2. Rout in every template opening.

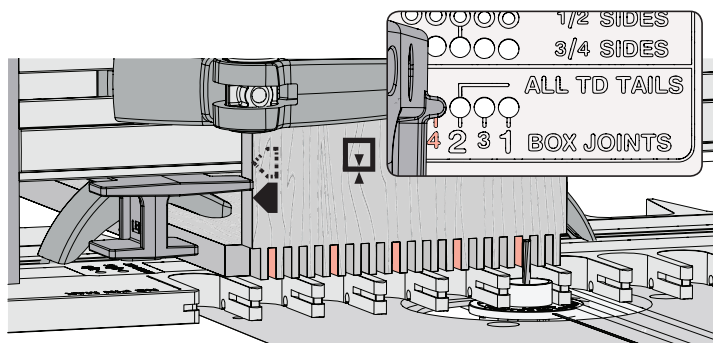

**13-29** Leave the board in place. Unlatch the frame and move the right frame pin to position 4. Rout in every template opening. Unclamp and flip the board, keeping the same side edge against the side stop. Clamp it and repeat the steps in reverse order. Remove socket board 1. Repeat the procedure for socket board 2. Remove socket board 2. All boards are now complete and ready for assembly.

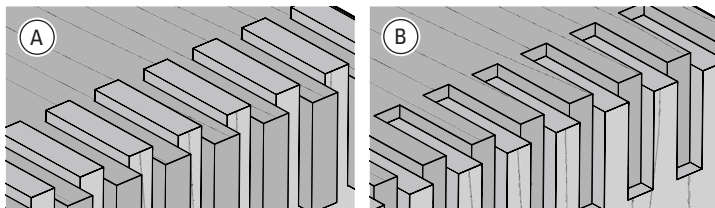

OVER FLUSH

UNDER FLUSH

**13-30** If the joint is over flush (A), lower the bit to suit. If the joint is under flush (B), raise the bit to suit. Rout a fresh test joint until fit and flushness are perfect before routing the actual workpieces. ■

## CHAPTER 14

# Jig Parts

When ordering parts, please quote the jig model, serial number, part number, part description and quantity required.

<b>PART DESCRIPTION</b>	<b>PART NO.</b>	<b>QUANTITY</b>
Template Extrusion, Machined	2500	1
Frame Extrusion, Machined	2505	1
Left Hand Handle	2511	1
Right Hand Handle	2516	1
Cam Clamp Handles	2520	4
Cam Lock Hold-Downs	2525	4
Clamp Arm Lever Platforms	2530	4
Clamp Arm Spring Washers	2535	4
Latches	2540	2
Latch Washers	2545	2
Side Stops	2551	2
Bit Depth Gauge, Plastic	2555	1
Blockers	2560	10
Clamp Pivot Nuts	2565	4
Clamp Springs	2570	4
Clamp T-Bolts	2575	4
Quick Reference Strip, Through Dovetails	2580	1
Quick Reference Strip, Half Pitch Through Dovetails	2581	1
Quick Reference Strip, Half-Blind Dovetails	2582	1
Quick Reference Strip, $\frac{3}{8}$ " and $\frac{3}{4}$ " Box Joints	2583	1
Quick Reference Strip, $\frac{3}{16}$ " and $\frac{3}{32}$ " Box Joints	2584	1
User Guide	2590	1
Hex Key, $\frac{1}{8}$ " Ball End	2595	1
DVD Instructional Video	2596	1
Guide Bushing, Elliptical (eBush)	e10	1
Pin Wrench	730V	1
Dovetail Bit, $\frac{1}{2}$ " x $1\frac{3}{16}$ " x $8^\circ$	80-500	1
Dovetail Bit $\frac{1}{2}$ " x $\frac{1}{2}$ " x $14^\circ$	120-500	1
Straight Bit, $\frac{3}{8}$ " x $1\frac{1}{4}$ "	143-500	1
Straight Bit, $\frac{1}{2}$ " x $1\frac{1}{4}$ " Two Flute	160	1
Stop rod, Nylon, 18"	8618	1
Handle Screws, 8 x $1\frac{1}{4}$ "	260R	2
Latch Nuts, Nyloc, 10-24	2065	2
Handle Screws, 10 x $1\frac{1}{4}$ "	6145	2
Side Stop Screws, Button Head, 10-24 x $\frac{7}{16}$ "	6410716	2
Latch Screws, 10-24 x $\frac{3}{4}$ "	9130	2
Side stop Nuts, Square, 10-24	9140	2

*See Parts Diagram on next page*

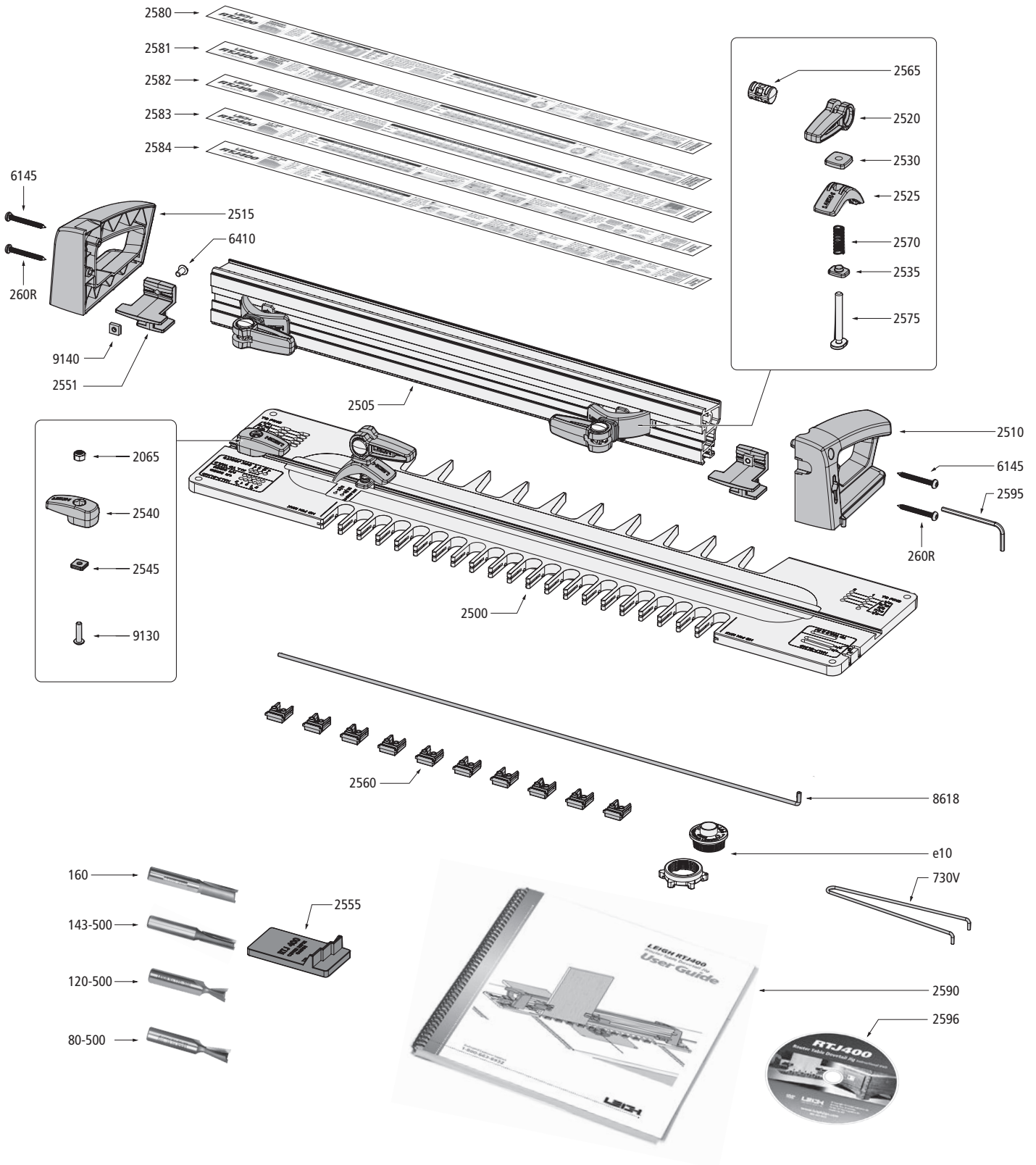



**RTJ400 OPERATION**

## CHAPTER 15

# Customer Support

**Our Commitment to You** Leigh Industries takes pride in its commitment to providing excellence in customer service and support. This user guide is designed to provide you with the answers to any questions you have. However, if you require assistance, please feel free to contact our technical support staff or a distributor listed below.

### Manufacturer: Canada/USA

#### TEL/FAX

**Customer Service and Technical Support**  
800-663-8932 (Canada/USA)  
604-464-2700 (Tel.)  
604 464-7404 (Fax.)

#### EMAIL/WEB

**Customer Service**  
leigh@leighjigs.com  
**Technical Support**  
help@leighjigs.com  
**Website**  
www.leighjigs.com

**NOTE:** Email can be useful, but technical queries usually raise queries from us. A phone call is the quickest and most convenient way to get queries answered, either directly to Leigh (toll free in N. America) or to your national distributor. –**Thanks!**

#### MAILING ADDRESS

Leigh Industries Ltd.  
P.O. Box 357  
Port Coquitlam, B.C.  
Canada V3C 4K6

#### LOCATION

Leigh Industries Ltd.  
1615 Industrial Ave.  
Port Coquitlam, B.C.  
Canada V3C 6M9

### Distributors

#### AUSTRALIA & NEW ZEALAND

Maxis Distribution  
128 Ingleston Rd., Wakerley, Qld., 4154  
Australia  
Tel: 1300 767 366  
Tel (Int.) +61 7 3292 0392  
Email: info@maxis.com.au  
Web: www.maxis.com.au

#### CHINA

Harvey Industries Co., Ltd.  
68-10 Suyuan Avenue  
Jiangning District Nanjing 211100, China  
Tel: (0)86 5792 8869 / 5792 8021  
Fax: (0)86 5792 8826  
Email: caozhi@harvey.cn  
Website: www.harveyworks.cn

#### FRANCE

Ets Bordet  
98 Rue Louis Ampère, 93330  
Neuilly Sur Marne, France  
Tel: 01 48 58 28 39  
Fax: 01 48 58 48 58  
Email: info@bordet.fr  
Web: www.bordet.fr

#### GERMANY, AUSTRIA & SWITZERLAND

Hacker GmbH  
Holzbearbeitungsmaschinen  
Traberhofstraße 103 D-83026 Rosenheim  
Deutschland  
Tel: 08031 269650  
Fax: 08031 68221  
Email: hacker.rosenheim@t-online.de  
Web: www.leigh.de

#### ITALY

Ferrari Macchine Legno SRL  
Via Gallarata 74/76/78  
20019 Settimo M.se (MI) Italy  
Tel: 39 02 335 010 95  
Fax: 39 02 335 005 27  
Email: info@ferrarimacchine.com  
Web: www.ferrarimacchine.com

#### JAPAN

Off Corporation Inc.  
323-1 Yanbara, Shimizu-ku, Shizuoka-shi  
Shizuoka-ken, Japan 424-0002  
Tel: 81-50-3816-0115  
Fax: 81-54-367-6515  
Email: info@off.co.jp  
Web: www.off.co.jp

#### KOREA

Leigh Korea  
665-3, Munhyung-Ri, Opo-Eup, Kwangju-Si,  
12774, South Korea  
Tel: 82 (0) 70-8252-0988  
Fax: 82 (0) 31-765-5602  
Email: maengha@leigh.co.kr  
Web: www.leigh.co.kr

#### NETHERLANDS, BELGIUM & LUXEMBOURG

Houtbewerking Krielaart  
9217RR Nijega, Netherlands  
Tel: +31 512 354 770  
Email: gerard@gkrielaart.nl  
Web: www.leighjigs.nl

#### RUSSIA

Unicom Ltd.  
Nikitskij Boulevard 12  
Moscow, 119019, Russia  
Tel: 7 (495) 690 0454  
Email: info@leighjigs.ru  
Web: www.leighjigs.ru

#### SOUTH AFRICA

Hardware Centre  
PO Box 4059, Randburg 2125  
South Africa  
Tel: +27 011 791-0844/46  
Fax: +27 011 791-0850  
Email: info@hardwarecentre.co.za  
Web: www.hardwarecentre.co.za

#### SWEDEN

Toolbox Sweden AB  
Bruksgatan 3, S-597 30  
Atvidaberg, Sweden  
Tel: 46 120 854 50  
Fax: 46 120 854 69  
Email: info@toolbox.se  
Web: www.toolbox.se

#### UNITED KINGDOM & IRELAND

Axminster Tools & Machinery  
Headquarters, Unit 10, Weycroft Avenue  
Axminster, Devon  
EX13 5PH United Kingdom  
Tel: 0800 371822  
Text: 07786 200699  
Email: cs@axminster.co.uk  
Web: www.axminster.co.uk/leigh

RTJ400 OPERATION

# CHAPTER 16

## Quick Reference

### Board Width Selection for Dovetails

#### Through Dovetails (Full Pitch)

Board widths are based on the number of full tails (A) in your design. Board edges should always end in a half-pin (B).

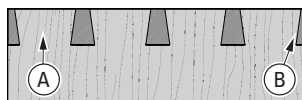

Board Width Selection for Through Dovetails											
No. of Tails	1	2	3	4	5	6	7	8	9	10	
Inches	Min	1 7/16"	3"	4 9/16"	6 1/8"	7 11/16"	9 1/4"	10 13/16"	12 3/8"	13 15/16"	15 1/2"
	Exact	1 9/16"	3 1/8"	4 11/16"	6 1/4"	7 13/16"	9 3/8"	10 15/16"	12 1/2"	14 1/16"	15 5/8"
	Max	1 15/16"	3 1/2"	5 1/16"	6 3/8"	8 3/16"	9 3/4"	11 5/16"	12 7/8"	14 7/16"	16"
Millimeters	Min	37	76	116	156	196	235	275	315	355	394
	Exact	40	80	119	159	199	239	278	318	358	398
	Max	49	89	129	169	208	248	288	328	367	407

#### Half-Pitch Through Dovetails

Board widths are based on the number of full tails (A) in your design. Board edges should always end in a half-pin (B).

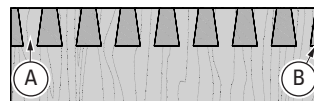

Board Width Selection for Half Pitch Through Dovetails																					
No. of Tails	1	2	3	4	5	6	7	8	9	10	11	12	13	14	15	16	17	18	19	20	
Inches	Min	2 3/32"	1 1/2"	2 9/32"	3 1/16"	3 27/32"	4 9/16"	5 13/32"	6 3/16"	6 31/32"	7 3/4"	8 17/32"	9 9/16"	10 3/32"	10 7/8"	11 21/32"	12 7/16"	13 7/32"	14"	14 29/32"	15 1/16"
	Exact	2 5/32"	1 9/16"	2 11/32"	3 1/8"	3 29/32"	4 11/16"	5 15/32"	6 1/4"	7 1/32"	7 13/16"	8 19/32"	9 3/8"	10 5/32"	10 15/16"	11 23/32"	12 1/2"	13 9/32"	14 1/16"	14 27/32"	15 5/8"
	Max	2 9/32"	1 11/16"	2 15/32"	3 1/4"	4 1/32"	4 13/16"	5 19/32"	6 3/8"	7 5/32"	7 15/16"	8 23/32"	9 1/2"	10 9/32"	11 1/16"	11 27/32"	12 5/8"	13 13/32"	14 3/16"	14 31/32"	15 3/4"
Millimeters	Min	18	38	58	77	97	117	137	156	176	196	216	235	255	275	295	314	334	354	374	393
	Exact	20	40	59	79	99	119	138	158	178	198	217	237	257	277	296	316	336	356	375	395
	Max	23	43	62	82	102	122	141	161	181	201	220	240	260	280	299	319	339	359	378	398

#### Half-Blind Dovetails

Board widths are based on the number of full tails (A) in the joint design. Board edges always end with a half pin (B). Board widths in the chart below may be increased by 1/4" [6mm] or decreased by 1/8" [3mm] if required.



Board Width Selection for Half-Blind Dovetails																					
No. of Tails	1	2	3	4	5	6	7	8	9	10	11	12	13	14	15	16	17	18	19	20	
Inches	Min	2 1/32"	1 7/16"	2 7/32"	3"	3 25/32"	4 9/16"	5 11/32"	6 1/8"	6 29/32"	7 11/16"	8 15/32"	9 1/4"	10 1/32"	10 13/16"	11 19/32"	12 3/8"	13 5/32"	13 15/16"	14 23/32"	15 1/2"
	Exact	2 5/32"	1 9/16"	2 11/32"	3 1/8"	3 29/32"	4 11/16"	5 15/32"	6 1/4"	7 1/32"	7 13/16"	8 19/32"	9 3/8"	10 5/32"	10 15/16"	11 23/32"	12 1/2"	13 9/32"	14 1/16"	14 27/32"	15 5/8"
	Max	1 3/32"	1 13/16"	2 19/32"	3 3/8"	4 3/32"	4 13/16"	5 23/32"	6 1/2"	7 11/16"	8 1/16"	8 27/32"	9 3/8"	10 13/32"	11 3/16"	11 31/32"	12 3/4"	13 17/32"	14 3/16"	15 3/32"	15 7/8"
Millimeters	Min	17	37	56	76	96	116	136	155	175	195	215	234	254	274	294	313	333	353	373	392
	Exact	20	40	60	79	99	119	139	158	178	198	217	237	257	277	297	316	336	356	376	395
	Max	26	45	65	85	105	124	144	164	184	203	223	243	263	282	302	322	342	361	381	401

**Board Width Selection for Box Joints**

**3/8" Box Joints**

Board widths are determined by the total number of pins and sockets in the joint design and whether the joint is symmetrical or asymmetrical. Use this chart to determine board widths up to 16" [406mm].

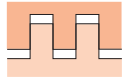

**Symmetrical Joints** have a full pin at each board edge. The total number of pins and sockets is always an odd number.

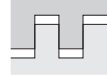

**Asymmetrical joints** have a full pin on one edge and a full socket on the other edge. The total number of pins and sockets is always an even number.

Symmetrical Board Width Chart for 3/8" Box Joints																				
Total Pins & Sockets	3	5	7	9	11	13	15	17	19	21	23	25	27	29	31	33	35	37	39	41
Inches	1 5/32"	1 15/16"	2 23/32"	3 1/2"	4 9/32"	5 1/16"	5 27/32"	6 5/8"	7 13/32"	8 3/16"	8 31/32"	9 3/4"	10 17/32"	11 5/16"	12 3/32"	12 7/8"	13 21/32"	14 7/16"	15 7/32"	16
Millimeters	29	49	69	89	109	129	148	168	188	208	228	248	267	287	307	327	347	367	387	406

Asymmetrical Board Width Chart for 3/8" Box Joints																			
Total Pins & Sockets	4	6	8	10	12	14	16	18	20	22	24	26	28	30	32	34	36	38	40
Inches	1 9/16"	2 11/32"	3 1/8"	3 29/32"	4 11/16"	5 15/32"	6 1/4"	7 1/32"	7 13/16"	8 19/32"	9 3/8"	10 5/32"	10 15/16"	11 23/32"	12 1/2"	13 9/32"	14 1/16"	14 27/32"	15 5/8"
Millimeters	40	60	79	99	119	139	159	179	198	218	238	258	279	298	318	337	357	377	397

**3/8" Half-Blind Box Joints**

Board widths are based on the number of full tails (A) in the joint design. Board edges always end with a half pin (B). Board widths may be increased by 1/4" [6mm] or decreased by 1/8" [3mm] if required.

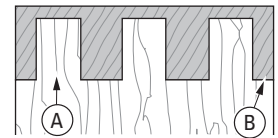

Board Width Selection for 3/8" Half-Blind Box Joints																					
No. of Tails	1	2	3	4	5	6	7	8	9	10	11	12	13	14	15	16	17	18	19	20	
Inches	Min	2 1/32"	1 7/16"	2 7/32"	3"	3 25/32"	4 9/16"	5 11/32"	6 1/8"	6 29/32"	7 11/16"	8 15/32"	9 1/4"	10 1/32"	10 13/16"	11 19/32"	12 3/8"	13 5/32"	13 15/16"	14 23/32"	15 1/2"
	Exact	2 5/32"	1 9/16"	2 11/32"	3 1/8"	3 29/32"	4 11/16"	5 15/32"	6 1/4"	7 1/32"	7 13/16"	8 19/32"	9 3/8"	10 5/32"	10 15/16"	11 23/32"	12 1/2"	13 9/32"	14 1/16"	14 27/32"	15 5/8"
	Max	1 1/2"	1 13/16"	2 19/32"	3 3/8"	4 3/32"	4 15/16"	5 23/32"	6 1/2"	7 11/16"	8 1/16"	8 27/32"	9 5/8"	10 13/32"	11 3/16"	11 31/32"	12 3/4"	13 17/32"	14 5/16"	15 3/32"	15 7/8"
No. of Tails	1	2	3	4	5	6	7	8	9	10	11	12	13	14	15	16	17	18	19	20	
Millimeters	Min	17	37	56	76	96	116	136	155	175	195	215	234	254	274	294	313	333	353	373	392
	Exact	20	40	60	79	99	119	139	158	178	198	217	237	257	277	297	316	336	356	376	395
	Max	26	45	65	85	105	124	144	164	184	203	223	243	263	282	302	322	342	361	381	401

**3/4" Box Joints**

Board widths are determined by the total number of pins and sockets in the joint design and whether the joint is symmetrical or asymmetrical. Use this chart to determine board widths up to 15 5/8" [397mm].

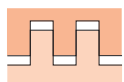

**Symmetrical Joints** have a full pin at each board edge. Total no. of pins and sockets is always an odd number.

Symmetrical Board Width Chart for 3/4" Box Joints									
Total Pins & Sockets	3	5	7	9	11	13	15	17	19
Inches	2 11/32"	3 29/32"	5 15/32"	7 1/32"	8 19/32"	10 5/32"	11 23/32"	13 9/32"	14 27/32"
Millimeters	60	99	139	179	218	258	298	337	377



**Asymmetrical joints** have a full pin on one edge and a full socket on the other edge. Total no. of pins and sockets is always an even number.

Asymmetrical Board Width Chart for 3/4" Box Joints									
Total Pins & Sockets	4	6	8	10	12	14	16	18	20
Inches	3 1/8"	4 11/16"	6 1/4"	7 13/16"	9 3/8"	10 15/16"	12 1/2"	14 1/16"	15 5/8"
Millimeters	79	119	159	198	238	278	318	357	397

### Board Width Selection for Box Joints cont.

#### 3/16" Box Joints

Board widths are determined by the total number of pins and sockets in the joint design and whether the joint is symmetrical or asymmetrical. Use this chart to determine board widths up to 8" [203mm] for 3/16" joints. For wider boards, see leighjigs.com.

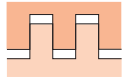

**Symmetrical Joints** have a full pin at each board edge. The total number of pins and sockets will always be an odd number.

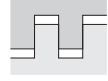

**Asymmetrical Joints** have a full pin at one edge and a full socket at the other. The total number of pins and sockets will always be an even number.

#### Symmetrical Board Width Chart for 3/16" Box Joints

Total Pins & Sockets	3	5	7	9	11	13	15	17	19	21	23	25	27	29	31	33	35	37	39	41
Inches	9/16"	3/32"	1 1/32"	1 3/4"	2 1/8"	2 17/32"	2 29/32"	3 5/16"	3 11/16"	4 3/32"	4 15/32"	4 7/8"	5 1/4"	5 27/32"	6 1/32"	6 7/16"	6 13/16"	7 7/32"	7 19/32"	8"
Millimeters	14	25	34	44	54	64	74	84	94	104	114	124	133	144	153	164	173	183	193	203

#### Asymmetrical Board Width Chart for 3/16" Box Joints

Total Pins & Sockets	4	6	8	10	12	14	16	18	20	22	24	26	28	30	32	34	36	38	40
Inches	25/32"	1 5/32"	1 9/16"	1 15/16"	2 1/32"	2 23/32"	3 1/8"	3 1/2"	3 29/32"	4 9/32"	4 11/16"	5 1/16"	5 15/32"	5 27/32"	6 1/4"	6 5/8"	7 1/32"	7 13/32"	7 13/16"
Millimeters	20	29	40	49	60	69	79	89	99	109	119	129	139	148	159	168	179	188	198

#### 3/32" Box Joints

Board widths are determined by the total number of pins and sockets in the joint design and whether the joint is symmetrical or asymmetrical. Use this chart to determine board widths up to 4" [102mm] for 3/32" joints. For wider boards, see leighjigs.com.

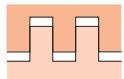

**Symmetrical Joints** have a full pin at each board edge. The total number of pins and sockets will always be an odd number.

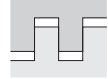

**Asymmetrical Joints** have a full pin at one edge and a full socket at the other. The total number of pins and sockets will always be an even number.

#### Symmetrical Board Width Chart for 3/32" Box Joints

Total Pins & Sockets	3	5	7	9	11	13	15	17	19	21	23	25	27	29	31	33	35	37	39	41
Inches	9/32"	15/32"	1 1/16"	7/8"	1 1/16"	1 1/4"	1 15/32"	1 21/32"	1 27/32"	2 1/32"	2 1/4"	2 7/16"	2 5/8"	2 13/16"	3 1/32"	3 7/32"	3 13/32"	3 19/32"	3 13/16"	4
Millimeters	7	12	17	22	27	32	37	42	47	52	57	62	67	71	77	82	87	91	97	102

#### Asymmetrical Board Width Chart for 3/32" Box Joints

Total Pins & Sockets	4	6	8	10	12	14	16	18	20	22	24	26	28	30	32	34	36	38	40
Inches	3/8"	9/16"	25/32"	3 1/32"	1 5/32"	1 11/32"	1 9/16"	1 3/4"	1 15/16"	2 1/8"	2 11/32"	2 17/32"	2 23/32"	2 29/32"	3 1/8"	3 5/16"	3 1/2"	3 11/16"	3 29/32"
Millimeters	10	15	20	25	29	34	40	44	49	54	60	64	69	74	79	84	89	94	99

