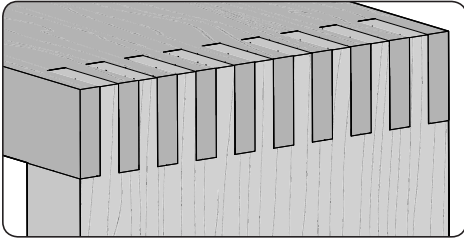

## RTJ400 OPERATION

## CHAPTER 12

## 3/16" Box (Finger) Joints

**IMPORTANT SAFETY NOTE**

Before using your Leigh RTJ400 you must have completed the preparatory steps listed in the previous pages, including reading the jig safety recommendations in Chapter 3.

**12-1 Getting Started**

Review the drawing below. **Symmetrical** joints have pins (A) on both edges of one board, and sockets (B) on both edges of the mating board. **Asymmetrical** joints have a pin (C) on one edge and a socket (D) on the other edge of each board.

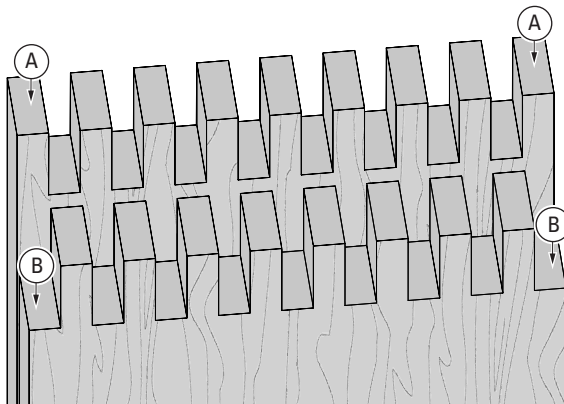

SYMMETRICAL

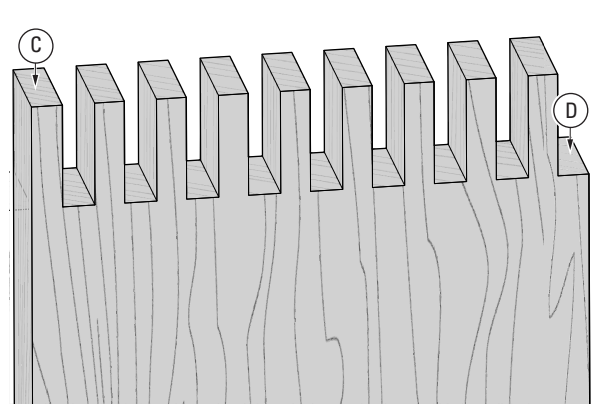

ASYMMETRICAL

**12-2 Bits, Guide Bushing and Stop Rod**

3/16" box joints are routed with the optional 3/16" Leigh straight bit 166 or 166C, the e10 guide bushing (eBush), and the stop rod (for positioning the side stop only). They can be routed in board thicknesses up to the maximum cutting depth of the bit, in this case, 5/8" [15.9mm].

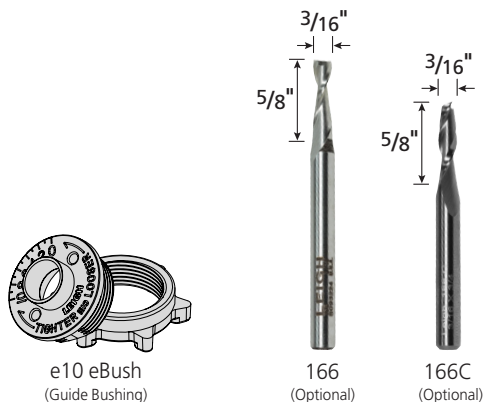

Stop Rod  
(For positioning side stop)

e10 eBush  
(Guide Bushing)

166  
(Optional)

166C  
(Optional)

**BOX JOINT BIT CUTTING DEPTH**

Bit Diameter	3/16"
Item No. (HSS)	<b>166</b>
Item No. (Solid Carbide)	<b>166C</b>
0"	
1/8"	
1/4"	
3/8"	
1/2"	
5/8"	
3/4"	
7/8"	
1"	

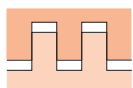

**Symmetrical Joints** have a full pin at each board edge. The total number of pins and sockets will always be an odd number.

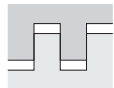

**Asymmetrical Joints** have a full pin at one edge and a full socket at the other. The total number of pins and sockets will always be an even number.

**Symmetrical Board Width Chart for 3/16" Box Joints**

Total Pins & Sockets	3	5	7	9	11	13	15	17	19	21	23	25	27	29	31	33	35	37	39	41
Inches	9/16"	31/32"	111/32"	1 3/4"	2 1/8"	2 17/32"	2 29/32"	3 5/16"	3 11/16"	4 3/32"	4 15/32"	4 7/8"	5 1/4"	5 21/32"	6 1/32"	6 7/16"	6 13/16"	7 7/32"	7 19/32"	8"
Millimeters	14	25	34	44	54	64	74	84	94	104	114	124	133	144	153	164	173	183	193	203

**Asymmetrical Board Width Chart for 3/16" Box Joints**

Total Pins & Sockets	4	6	8	10	12	14	16	18	20	22	24	26	28	30	32	34	36	38	40
Inches	25/32"	15/32"	19/16"	115/16"	211/32"	223/32"	3 1/8"	3 1/2"	3 29/32"	4 9/32"	4 11/16"	5 1/16"	5 15/32"	5 27/32"	6 1/4"	6 5/8"	7 1/32"	7 13/32"	7 13/16"
Millimeters	20	29	40	49	60	69	79	89	99	109	119	129	139	148	159	168	179	188	198

**12-3** Board widths are determined by the total number of pins and sockets in the joint design and whether the joint is symmetrical or asymmetrical. Use this chart to determine board widths up to 8" [203mm] for 3/16" joints. For wider boards, see [www.leighjigs.com](http://www.leighjigs.com).

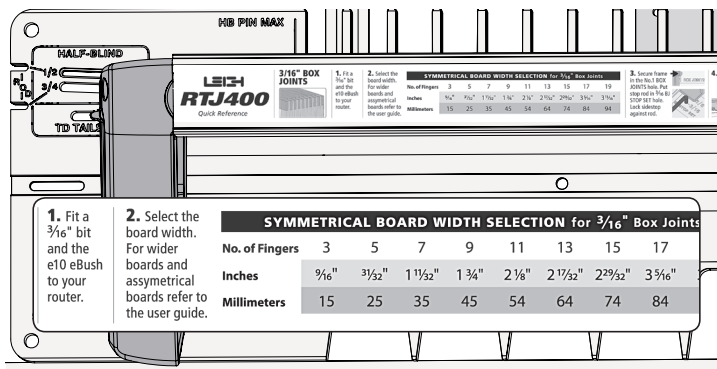

**12-4** Use the Quick Reference strip to determine the correct straight bit and eBush combination. **IMPORTANT NOTE:** Read the whole chapter before routing any boards, and see quick fit instructions in 12-14.

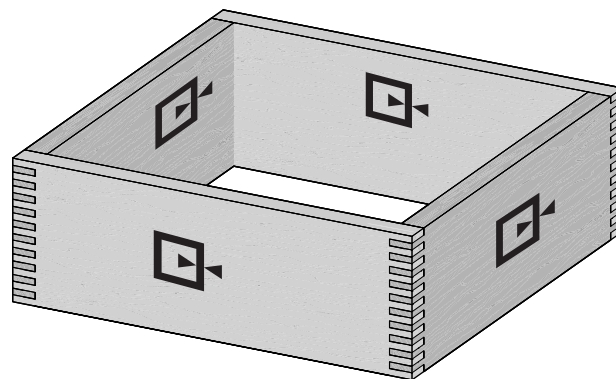

**12-5 Making a Box** Note the symbols indicating either side of the pin and socket boards can face in or out. With box joints, the same edge of the board goes against the side stop.

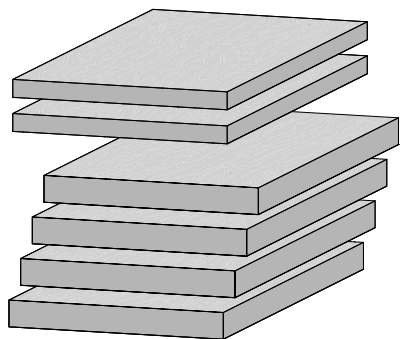

**12-6** Prepare four similar boards 5/8" x 4 5/8" by about 8" long [19mm x 115mm x 200mm]. For the quick fit test you'll need two test boards about 1/4" thick. Boards of different thicknesses may also be joined. **IMPORTANT: Read this whole chapter before routing any boards.**

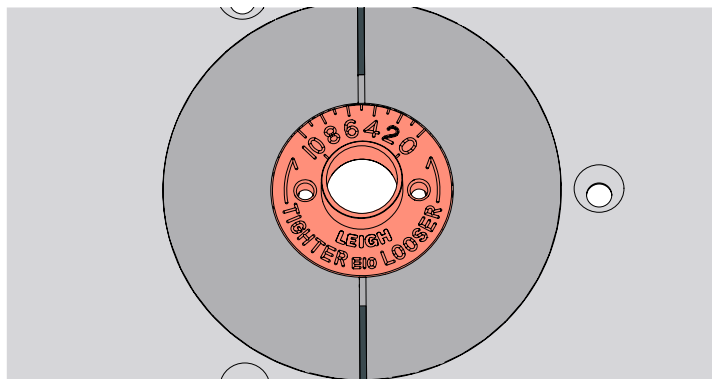

**12-7** Fit the e10 eBush to the router table insert ring set to 5, or if you have already done the quick fit test, use this setting instead.

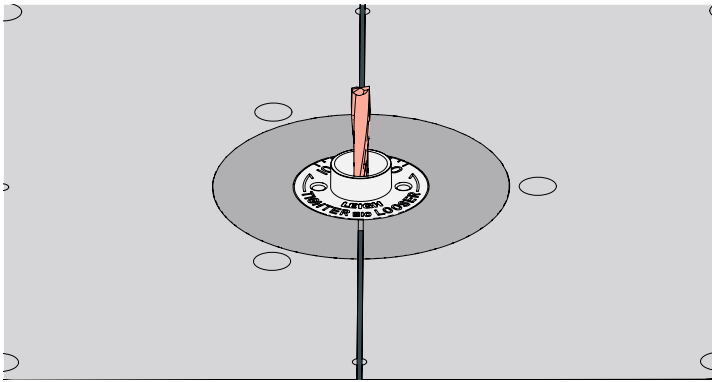

**12-8** With the power disconnected from the router, install the optional  $\frac{3}{16}$ " Leigh 166 (HSS) or 166C (solid carbide) bit. Make sure the bit spins freely in the bushing before reconnecting the power. Optional bits available at leighjigs.com

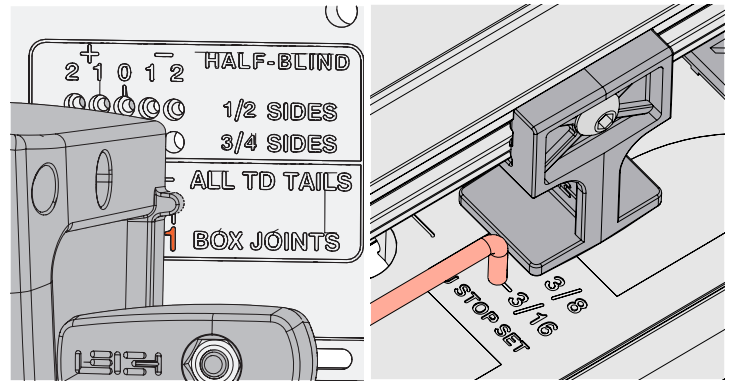

**12-9** Insert the right frame pin in the **No.1 hole, BOX JOINTS** mode and the left frame pin in the **TD TAILS & BJ slot**. Latch the frame. Put the short end of the stop rod into the **3/16" BJ STOP SET** hole. Slide the side stop to lightly touch the rod and tighten the side stop. Store the stop rod in the  $\frac{3}{4}$ " slot.

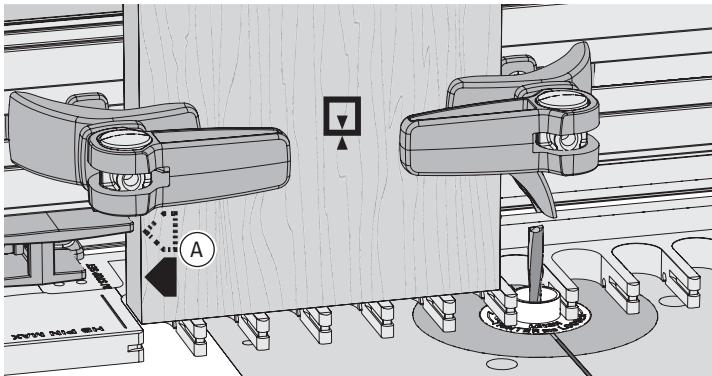

**12-10** Clamp pin board 1 vertically with the side edge against the side stop, the end edge flush on the template. **Always keep the same side edge of the board to the side stop when routing box joints** (A).

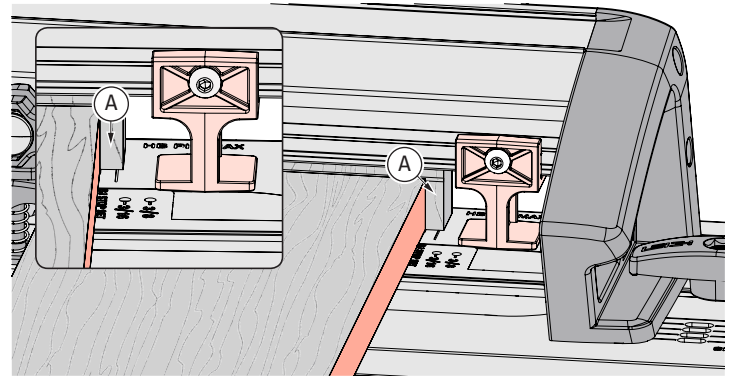

**12-11** Position a backer board at least  $\frac{3}{16}$ " [4.5mm] from the board edge (A). This prevents the backer board from interfering with the side stop when the frame is repositioned in the following steps. The backer board stays in place for the complete procedure. **Note: Clamp removed for clarity.**

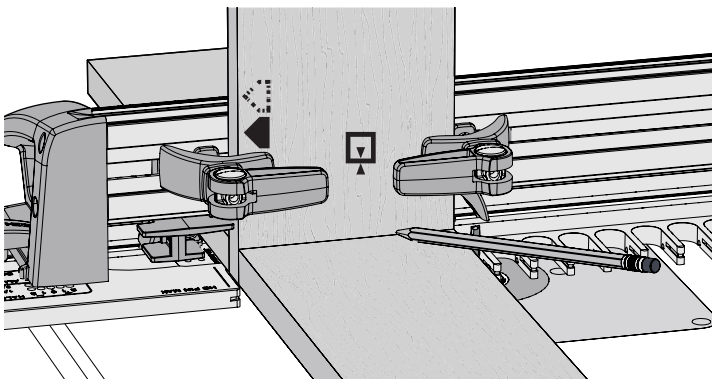

**12-12** Place the end of a socket board on the template and pencil a line on the pin board.

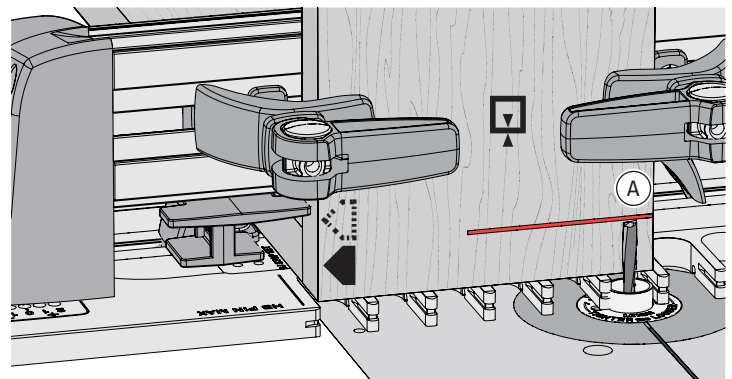

**12-13** Adjust the bit until the tip is level with the center of the pencil line on board 1 (A). **IMPORTANT: Bit height determines the flushness of the joint, so set your bit properly the first time.** Adjustments for flushness if required are at the end of the chapter. **⚠** Double check that the bit still rotates freely.

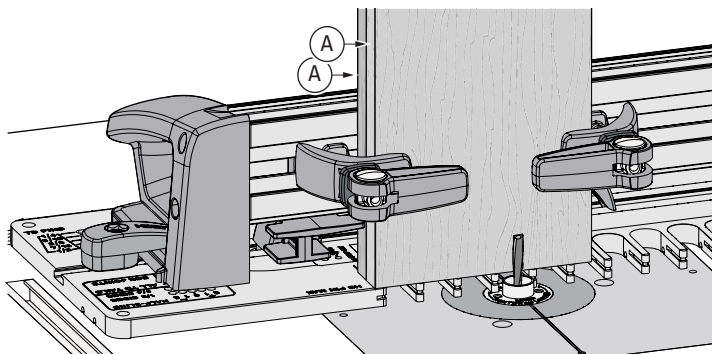

**12-14 Quick Fit Test** To save time and wood, clamp the two ¼" thick scrap **test** boards in the jig, back to back **A**. **⚠ Review the remaining steps in this chapter.** Rout both boards at the same time. Repeat again with the frame in the **No.2 hole, BOX JOINTS** mode. Join the routed boards and make joint fit adjustments in the next steps. Don't worry about board edge alignment, the test is for joint fit only.

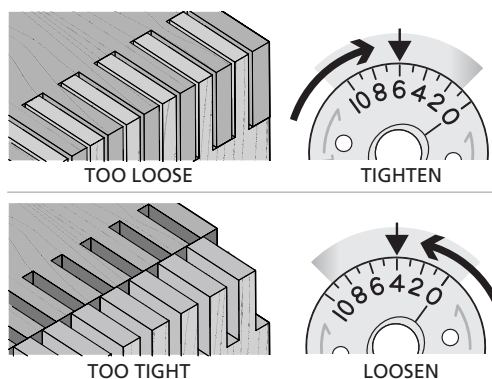

**12-15 Joint Fit Adjustment** Keep the same side board edges together. If the joint is too loose, turn the eBush to a higher number, as shown in the next step. If too tight, turn the eBush to a lower number.

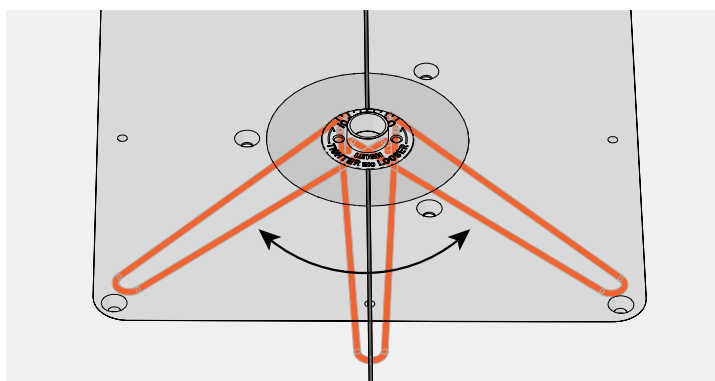

**12-16** Each increment on the eBush changes the joint glue line fit by 0.002" [0.05mm]. Half an increment, a mere 1000th inch! **Re-tighten the eBush nut after each guide bushing adjustment.** If necessary rout further test boards until correct joint fit is achieved, repeating Steps 12-14 through 12-16.

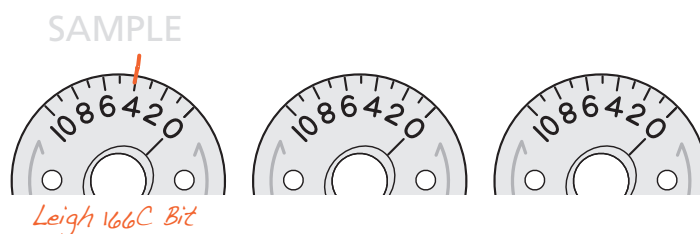

**12-17** On the eBushes above, record the settings you used to achieve perfect joint fit. The first eBush is an example of how to record your setting.

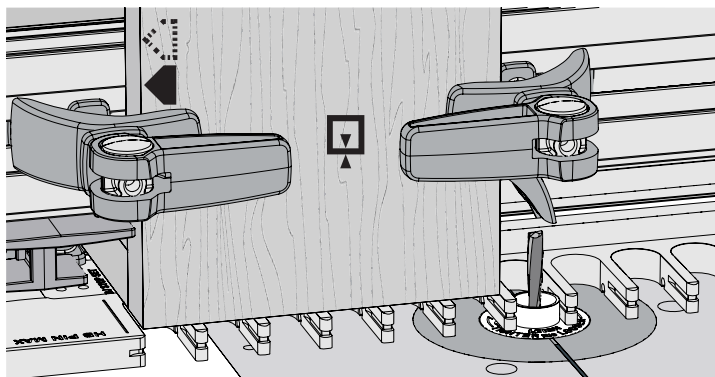

**12-18** Now that your joint tightness has been determined, re-clamp pin board 1 with the side edge against the side stop, the end edge flush on the template.

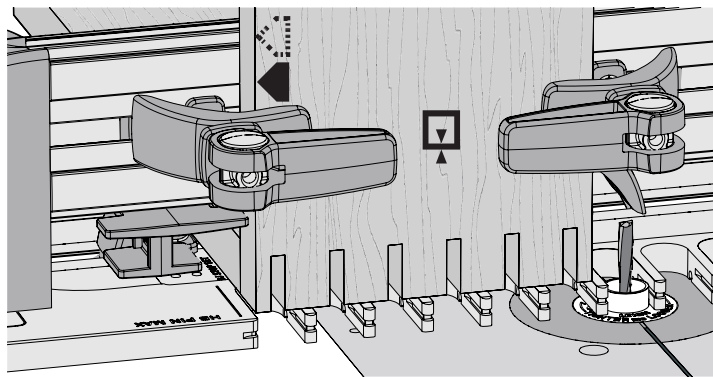

**12-19** Rout into every opening. **⚠ The eBush must touch one side of the opening as you enter and the other side as you exit. Do not remove the routed board or the backer board.**

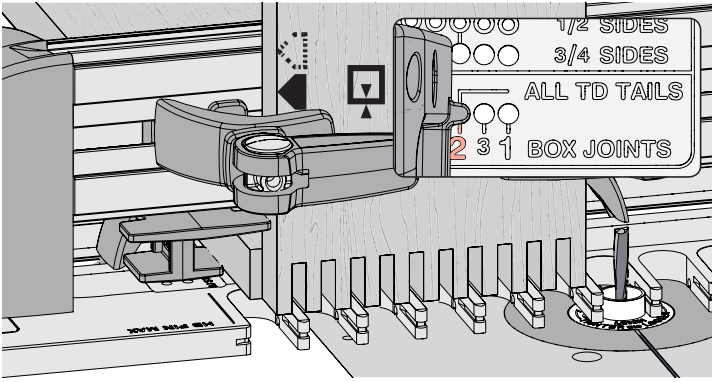

**12-20** Unlatch and move the right frame pin to the **No.2 hole, BOX JOINTS** mode, latch the frame. Rout into every opening. Unclamp and flip the board, keeping the same side against the side stop. Clamp it and repeat the steps in reverse order. Remove pin board 1 and repeat steps 12-19 and 12-20 for pin board 2.

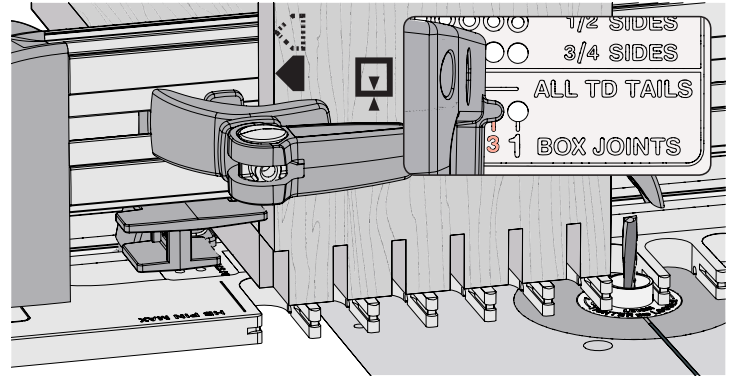

**12-21** Remove pin board 2. Unlatch and move the frame pin to the **No.3 hole, BOX JOINTS** mode and latch the frame. Clamp a socket board against the side stop and rout into all template openings.

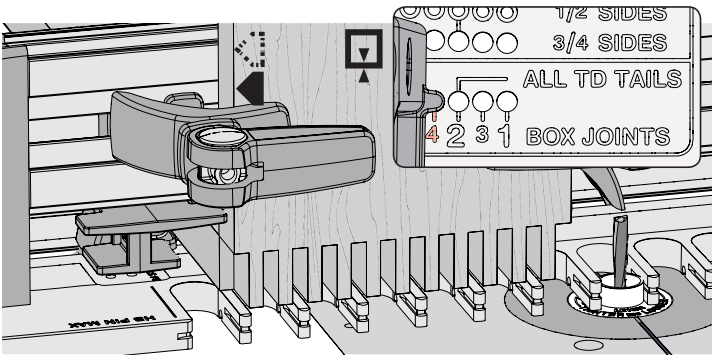

**12-22** Unlatch and move the frame pin to the **No.4 hole, BOX JOINTS** mode and latch the frame. Again, rout into all openings. Unclamp and flip the board, keeping the same edge against the side stop. Clamp it and repeat the routing in reverse order. Remove socket board 1 and repeat steps 12-21 and 12-22 for socket board 2. Remove socket board 2. All four boards are now complete and ready for assembly.

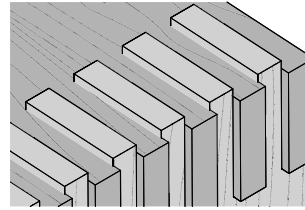

OVER FLUSH

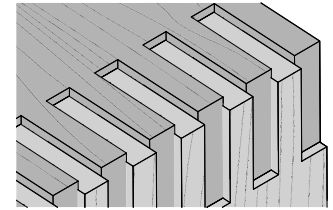

UNDER FLUSH

**12-23 Flushness** If the joint is **over flush**, lower the bit to suit. If the joint is **under flush**, raise the bit to suit. ■

