

LEIGH SUPERJIG **User Guide**

*For Leigh Super12, Super18
and Super24 Dovetail Jigs*

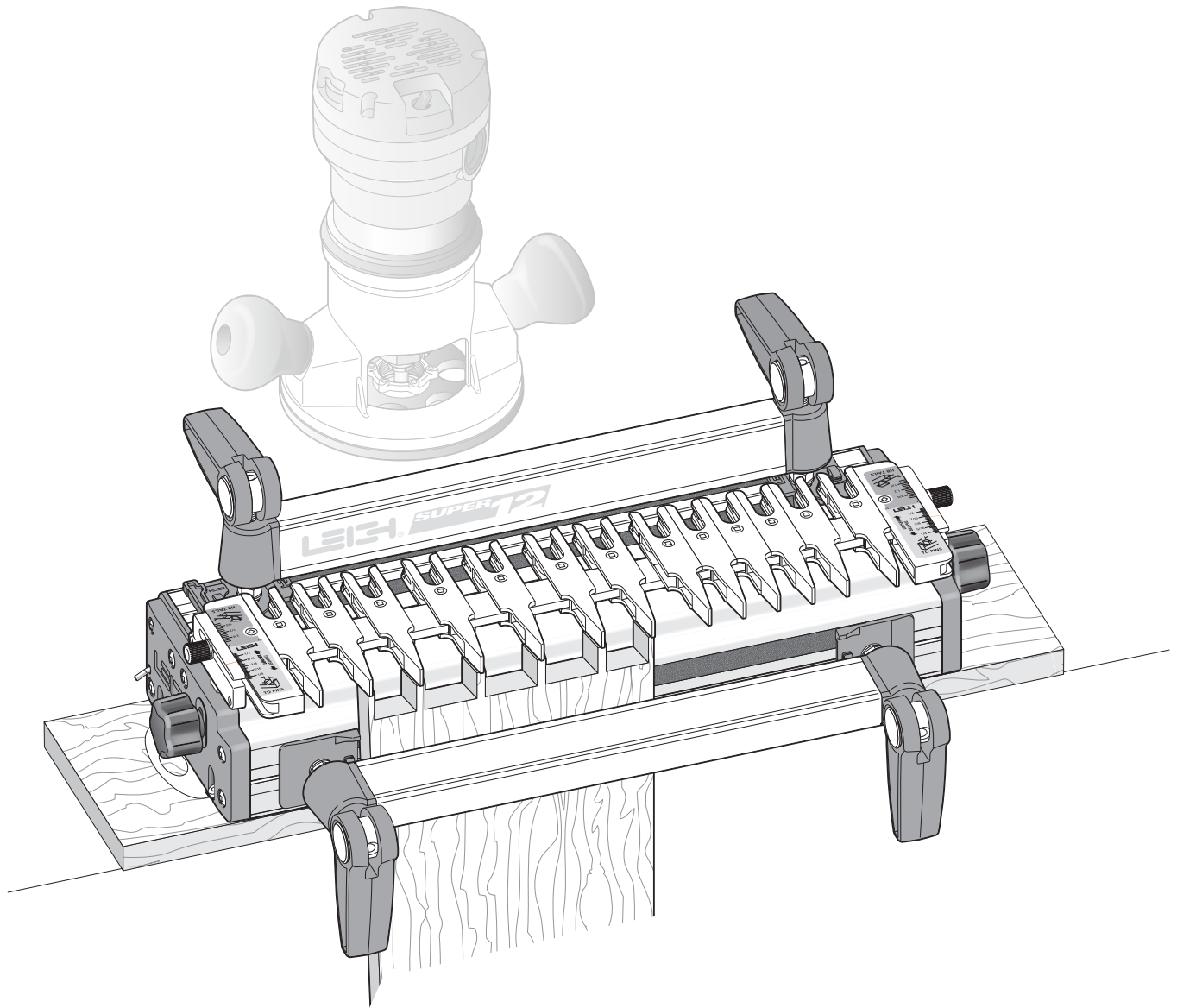

Dedicated Customer Support
1-800-663-8932

LEIGH[®]
Joining Tradition with Today

Your New Leigh Dovetail Jig

Congratulations! You now own a most useful and versatile dovetailing tool. The Leigh Superjig Dovetail Jig will help you cut an infinite variety of joints, and all of its major functions are described in detail in this user guide, plus there's a slide-out Quick Reference Guide underneath the jig. A very helpful DVD is also included, but the user guide is essential reading.

We recommend that you first assemble and mount the jig, carefully following the instructions in the first section of the user guide. Then read the rest of the guide, following along with the basic functions and principles of operation, before you try to do any actual joinery routing. By all means, cut a few practice joints in scrap boards before you use the jig to rout a precious hardwood work piece!

If you have questions not answered in this user guide, please call the Leigh customer support line: 1-800-663-8932 or email Leigh: help@leighjigs.com.

But remember: "If at first you don't succeed, read the instructions!"

*See Appendix IV – Customer Support

Important! Inches and Millimeters

The Superjig can be ordered in inch or metric versions. They're identical except for the calibration scales. This Leigh English-language user guide show measurements in both inches and millimeters, with "inches" first, followed by "millimeters" in square brackets.

Example: $\frac{3}{4}$ " x $5\frac{1}{2}$ " x 8" [20 x 140 x 200mm]

Do not be concerned if the inch/millimeter equivalents are not exact. Just use the dimensions which apply to your jig.

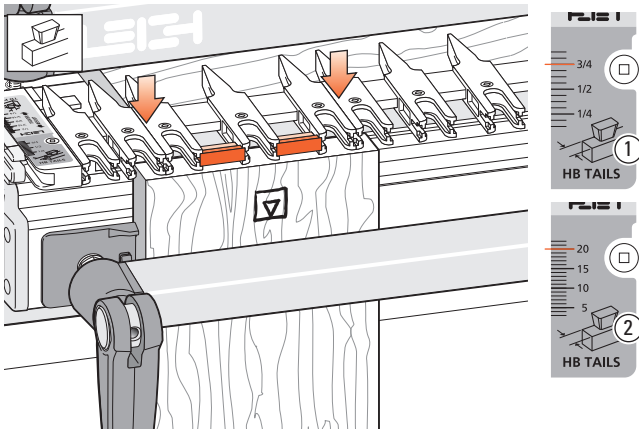

Where finger assembly scales overlay an illustration, the "inches" scale ① will be at the top, the "millimeters" scale ② will be at the bottom. Only the front "active" half of the scales are illustrated. For clarity, setting positions are indicated with a red line in the user guide only. **On the jig, the lines are black.**

Contents and Standards	iii
Chapter 1 – Jig Assembly, Mounting, and Using The Clamps	1
Chapter 2 – Adjusting the Finger Assembly	7
Chapter 3 – The Leigh e-Bush and Optional Guidebushes.....	9
Chapter 4 – Basic Jig Functions and Scale Modes	11
Chapter 5 – Using Your Jig Safely.....	13
Chapter 6 – Wood Preparation	15
Chapter 7 – Router Preparation	17
Chapter 8 – Through Dovetail Procedures	19
Chapter 9 – Variably Spaced Half-Blind Dovetail Procedures	29
Chapter 10 – Single Pass Half-Blind Dovetails	37
Chapter 11 – Rabbeted Half-Blind Dovetails	45
Chapter 12 – Asymmetric Dovetails	47
Chapter 13 – Sliding Dovetails.....	51
Chapter 14 – Box Joints.....	57
Chapter 15 – Hints and Tips	63
Appendix I – Attaching the Leigh e-Bush to the Router	67
Appendix II – Bit Selection	69
Appendix III – Jig Parts	75
Appendix IV – Customer Support.....	79

TECHNICAL BULLETINS

Downloadable pdfs are available at leighjigs.com on the Support page for these How To's and more for your Leigh Super Jig:

- Inlaid Through Dovetails On The D1600 and Super Jigs
- Wider Pins on the D1600 Jig and Super Jigs
- End-on-End Dovetails on the D1600 and Super Jigs

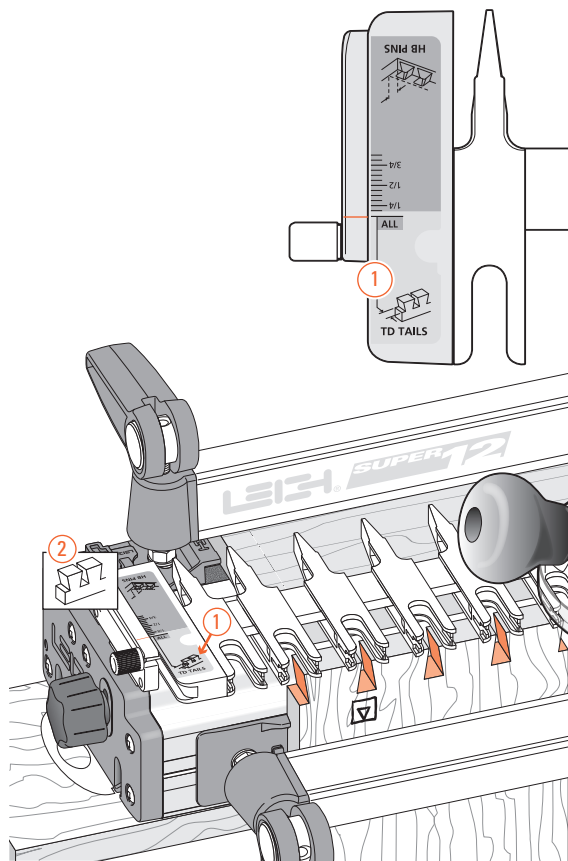

Glossary of Symbols

To help you understand the instructions and illustrations in this user guide, we have used a number of international symbols, plus a few special ones of our own. They are all explained below. **You needn't worry about memorizing these symbols now**, because they are repeated quite frequently throughout the user guide, and you will soon get used to them.

The Leigh jig's guidefinger assembly can be in any one of four joint modes, depending on what type of joint and which part of the joint you are routing. Each finger assembly scale has its own mode icon ①, identifying that joint part. You will also find the joint mode icon in the top left corner of most illustrations ②, indicating which finger assembly mode to use.

Sometimes a joint mode icon will be used to identify a board ③.

These are the four joint mode icons:

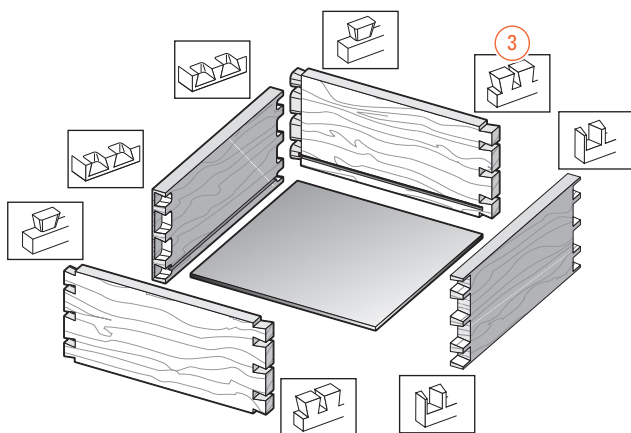

- 
TD Tails
 (tails for through dovetail joints)
- 
TD Pins
 (pins for through dovetail joints)
- 
HB Tails
 (tails for half-blind dovetail joints)
- 
HB Pins
 (pins for half-blind dovetail joints)

Which Way Round Should the Board Go?

As virtually all dovetail joinery is used to make boxes, drawers and chests etc., we devised these simple (and hopefully intuitive) icons to indicate which side of a board faces inwards or outwards on the finished “box”, and which side of the board faces outward (toward you, the operator), when it is clamped in the jig.

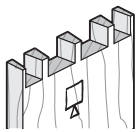
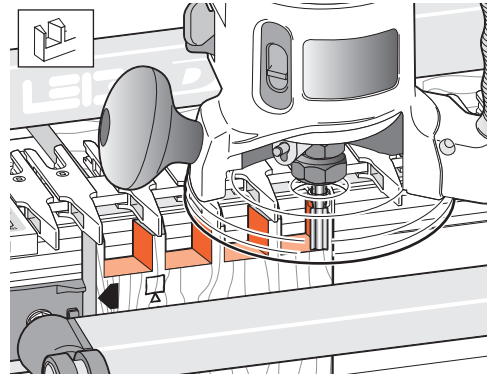

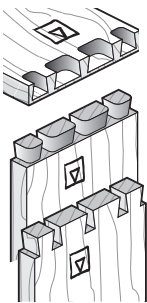

⬆ This icon  indicates the “outside” of a board. All through dovetail pin boards are mounted in the jig with this “outside” face away from the jig (toward you, the operator).

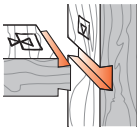

⬇ This icon  indicates the “inside” of a board. All half-blind pin and half-blind tail boards, and through dovetail tail boards, are mounted in the jig with the “inside” face away from the jig toward you, the operator.



⬆⬇ This icon  indicates boards that are mounted both ways e.g. sliding dovetails and box joints.

⋯ Dotted line icons  indicate the “other” side of the board in the illustrations.

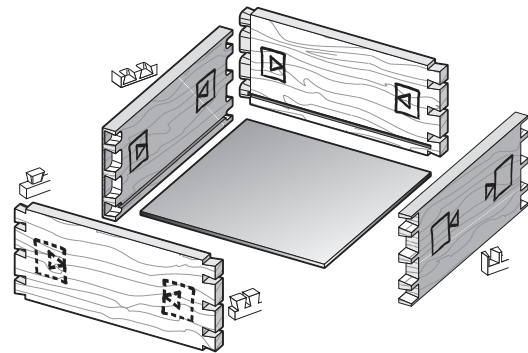

The following symbols indicate:



This edge against sidestop



This edge against sidestop



Sawcut allowance



Caution: use special care for this operation

①②③ Numbered References in text



Centerline of board or layout



Equals



Does not equal



Approximately

CONSIDER
THE...

Leigh VRS Vacuum & Router Support



Dust-Free Routing!

The revolutionary Leigh VRS Vacuum & Router Support* provides almost 100% dust and chip collection as well as amazing full width router support. The VRS is a must-have for all Leigh dovetail jig owners.

*US patent: USPN 7,507,060 B2 UK patent: GB2446909

Here's How It Works

The VRS is mounted on brackets on the front of the jig and the router is supported by the finger assembly and the full width beam of the VRS. The vacuum chute rides under the router support beam. Control arms, attached to the vacuum chute, surround the router. These arms are adjustable to accommodate any router base. As the router moves across the joint, the vacuum chute glides effortlessly from side to side on nylon rollers. The chute is always in perfect position to catch the dust and chips thrown out by the router bit. Chips and sawdust are drawn into the vacuum chute and down through the vacuum hose. Each VRS comes complete with two adaptors to fit all popular vacuum hose sizes and the VRS can be used with a small shop vac or a large built in system. The VRS is easily attached without jig modification. Each VRS comes complete with all mounting hardware needed for any Leigh 24" D-Series jig, all Super Jigs or the earlier model Leigh D1600.

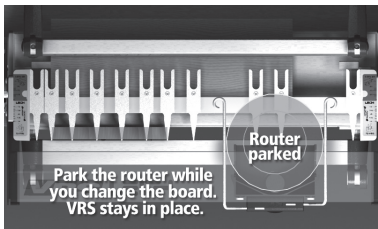

The VRS is a full width router support. When the work piece has been routed on one side of the jig, the router can be effortlessly moved to the other side of the jig and parked while the work piece is being changed. There is no need to remove the router from the jig.

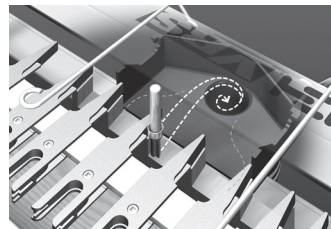

Because the vacuum box is always in perfect position relative to the router bit, the dust and chips coming off of the router bit are automatically drawn into the chute and vacuum hose.

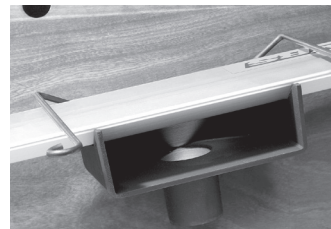

The dust chute rides beneath the router support beam. Control arms ensure accurate positioning of the chute and the size and shape of the chute ensures total waste collection regardless of bit size or joint type being routed.

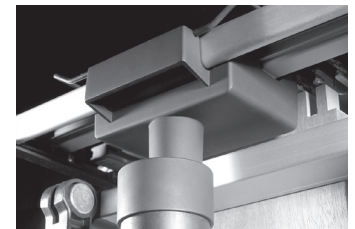

The VRS will work with almost any shop vac or large vac system. Two adaptors are included with every VRS to handle hose sizes from 1" to 2-1/2".

VRS Vacuum & Router Support Features

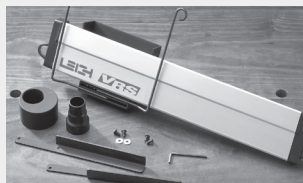

- Full width router support
- Easy on Easy Off. Powerful rare earth magnets secure router support beam
- Park the router when not in use
- Vacuum box glides effortlessly under router support beam
- Control arms position vacuum box
- Control arms adjust to any router
- No hoses to obstruct view
- No jig modifications necessary
- Models for all Leigh jigs
- All mounting hardware included
- Adapt to any hose size

Standard Equipment

- Router Support Beam
- Vacuum chute
- Hose adaptors – small and large
- Support rails
- Screws and washers
- Hex key

VRS Models

Item VRS12 Vacuum & Router Support for the Super 12 Dovetail Jig

Item VRS18 Vacuum & Router Support for the Super 18 Dovetail Jig

Item VRS24 Vacuum & Router Support for the Super 24 Dovetail Jig



Accessory Kits

Item AC12 VRS12 and 1607-8 Bit Set for the Super 12 Dovetail Jig

Item AC18 VRS18 and 1607-8 Bit Set for the Super 18 Dovetail Jig

Item AC24 VRS24 and 1607-8 Bit Set for the Super 24 Dovetail Jig

SUPERJIG - CHAPTER 1

Jig Assembly, Mounting, and Using the Clamps

Make Sure You Have All the Parts.

Before you start to assemble your Leigh SUPERJIG, check to make sure you have received all the required parts.

The small carton you removed from the end of the main carton contains:

1. 2 support brackets
2. 4 cam-action speed clamps
4 cam clamp pivot nuts
3. 1 e7-Bush & Nut with Pin Wrench
2 each, front and rear Side Stops
1 Spacer
4. 2 support knobs
5. 4 clamp springs
4 clamp T-bolts
4 flat washers
4 T-bolt nuts
4 Jig Hold-down Wood Screws No.10 x 1"
6. 2 scale thumbscrews c/w nylon washers
7. 2 Dovetail bits, 1 straight bit, 1 Collet Reducer
8. Square-head guidefinger screwdriver

Also included are any other small optional items you may have ordered with your new jig. Check the packing slip for this information.

The main carton contains:

9. 1 main jig body
1 Leigh jig User Guide
Warranty/Registration Card
DVD instructional video (English only)

The large inner box contains:

10. 1 finger assembly on a bar, complete with scales
Super 12, with 13 guidefingers
Super 18, with 16 guidefingers
Super 24, with 19 guidefingers
2 lengths bridge material – see Chapter 9
1 crosscut fence (same as bridge) – see Chapter 13
2 clamp bars c/w end plugs
1 Nylon Stop Rod – see Chapter 10
1 Quick Reference pull-out card

If any items are missing from your jig, contact your supplier or Leigh Industries immediately.

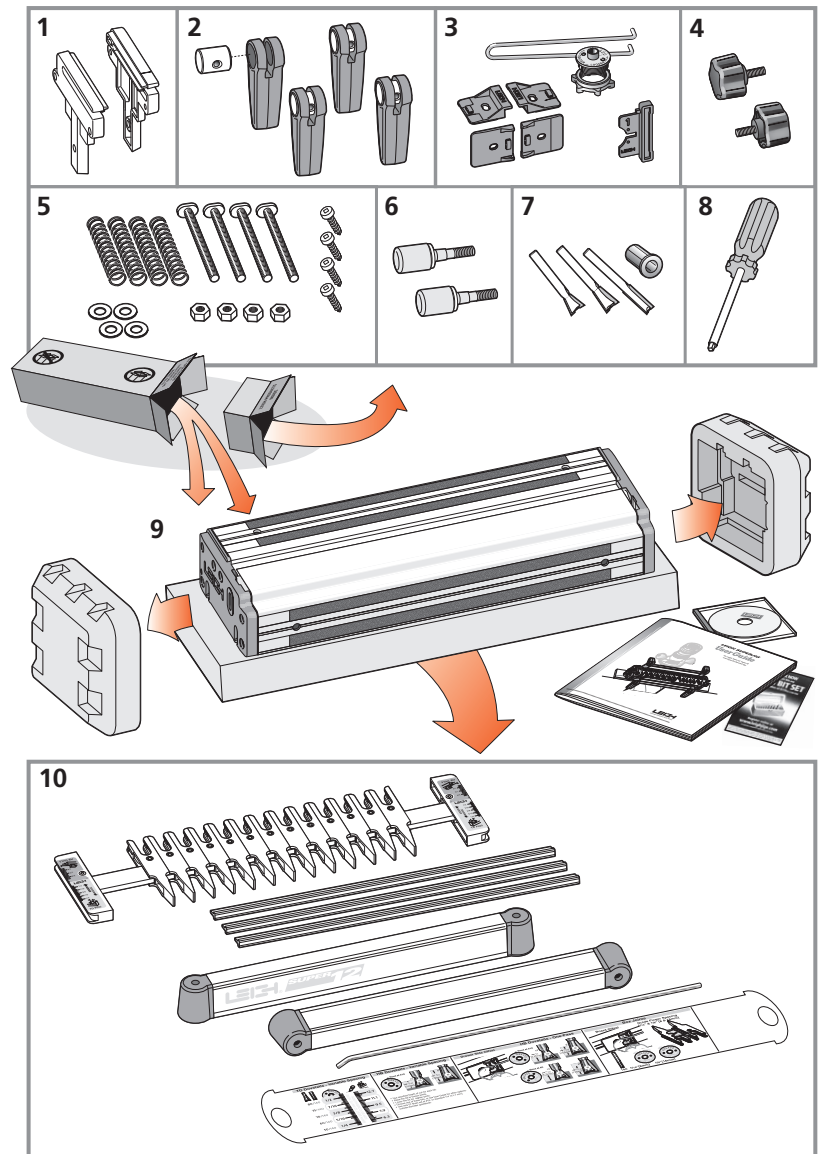

Important Note

Mount your jig securely, assemble it completely, and make sure you have read and understood the Safety section of this user guide before using the jig.

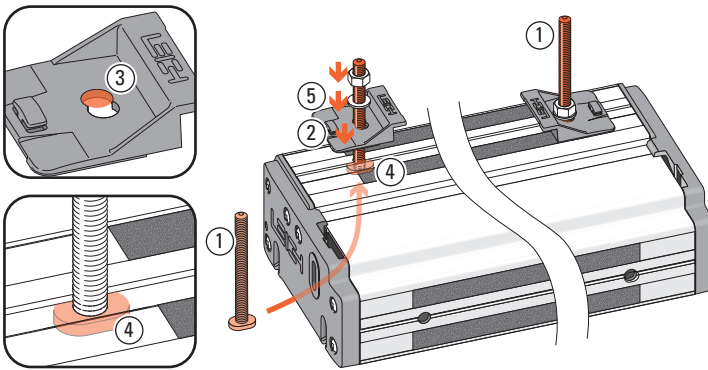

1-1 Install Side Stops Insert two clamp T-bolts through the rear jig body holes ① and place a “stepped” rear side stop over each bolt ②, using the rear part of the double-hole ③. Make sure the bolt’s “T” is between the extrusion ribs ④. Don’t forget the steel washer ⑤ and use a ½" [13mm] wrench to tighten the nuts.

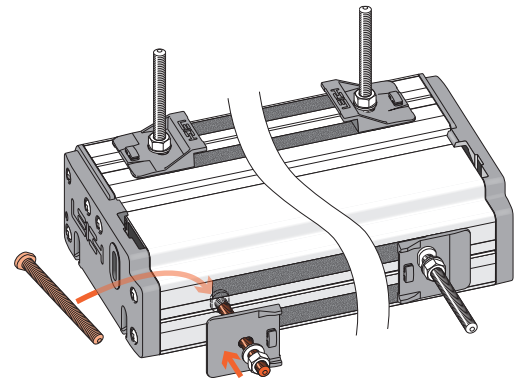

1-2 Insert the two front clamp T-bolts through the jig body holes. **Make sure the bolt’s “T” is between the extrusion ribs.** Place a front side stop and steel washer over each bolt but **only finger-tighten the front nuts**; you will need to index these to the rear stops later.

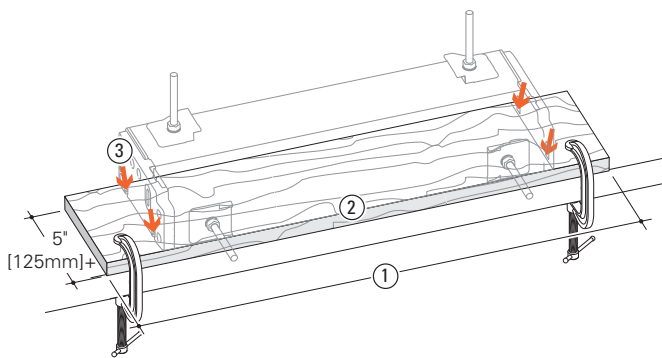

1-3 Prepare a flat ¾" [20mm] mounting board (plywood or MDF), at least 5" [125mm] wide. Length ①: 26" for Super12, 32" for Super18, 40" for Super24 [660, 830 or 1000mm respectively]. Clamp it to the front of your bench. Center the jig on the board, front face slightly overhanging the board edge ②. Mark the four hold down screw positions. Drill small pilot holes at a slight angle ③.

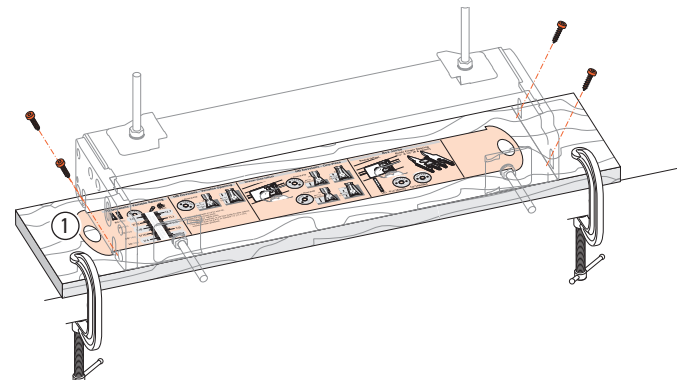

1-4 Quick Reference Pull-Out Decide which end of the jig you wish to access the “Quick Reference” instruction pull-out and place the jig over the pull-out ①. Using the screws provided; screw the jig to the board. Make sure that the pull-out slides freely.

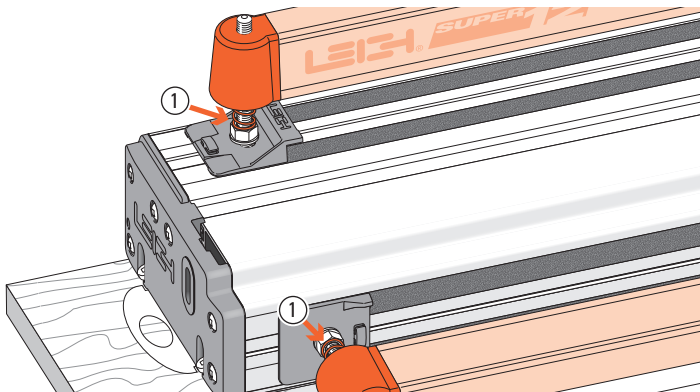

1-5 Place four springs ① and two clamp bars on the T-bolts. Make sure the clamp bars move freely on the T-bolts.

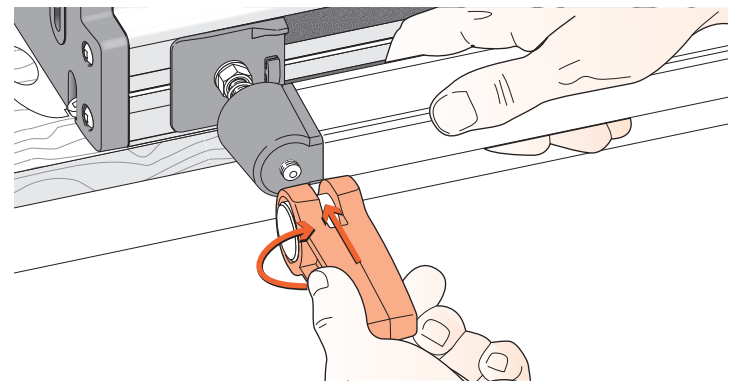

1-6 Screw a clamp lever assembly onto each T-bolt.

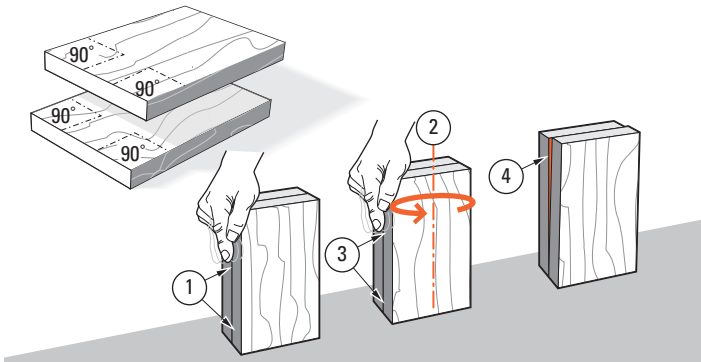

1-7 Now you need two boards about $\frac{3}{4}$ " x 6" x 8" long [20 x 150 x 200mm]. Both must have perfectly square ends to accurately index the front and rear side stops.

 Check for squareness: stand both pieces vertically on a flat surface. Make sure side edges are flush at bottom and top ①. Turn one piece around on its end ②. If side edges are flush top to bottom ③, the boards are square. If not, ④; cut two that are.

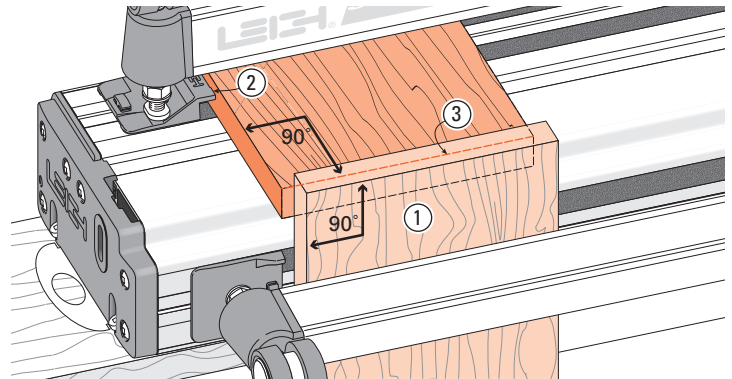

1-8 Align Front Side Stops Clamp one square ended board in the front, not touching the left side stop and with the top edge above the top surface of the jig body ①. Place the other square board in the rear clamp, tight against the left rear side stop ②, with its front edge touching flush across the rear of the vertical board ③. Tighten the rear clamp.
Note: Do not overtighten the right hand clamps during this step.

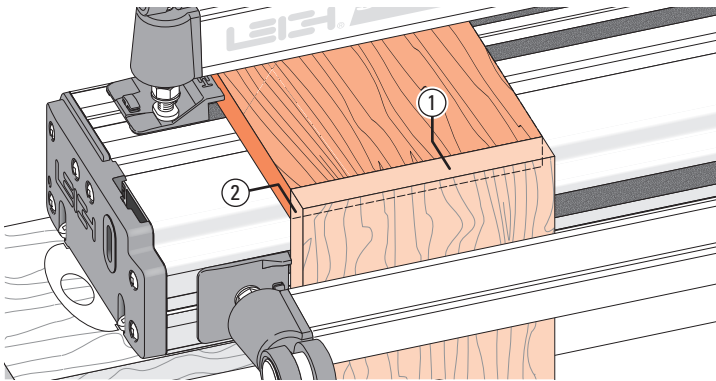

1-9 Now loosen the front clamp and position the front board so its top end edge is perfectly flush and level with the top face of the horizontal board ① and, both boards left edges are also perfectly flush ②. Tighten the clamp.

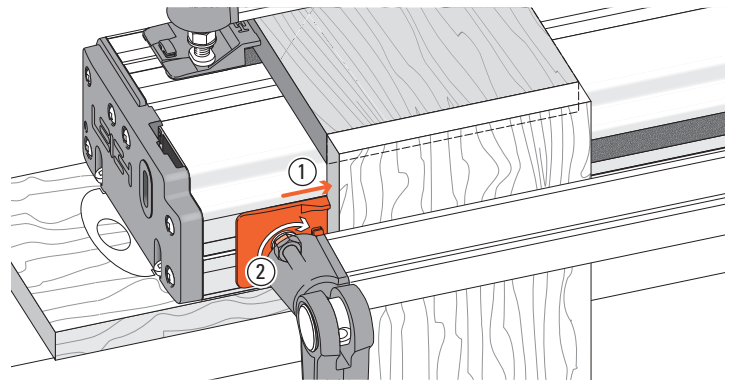

1-10 Now push the front left side stop inwards and flush against the vertical board ① and firmly tighten the clamp bolt nut. Repeat operations 1-8 thru 1-10 at the right side of the jig. The front and rear side stops are now indexed to provide accurate board alignment in all routing procedures. You may now remove the boards.

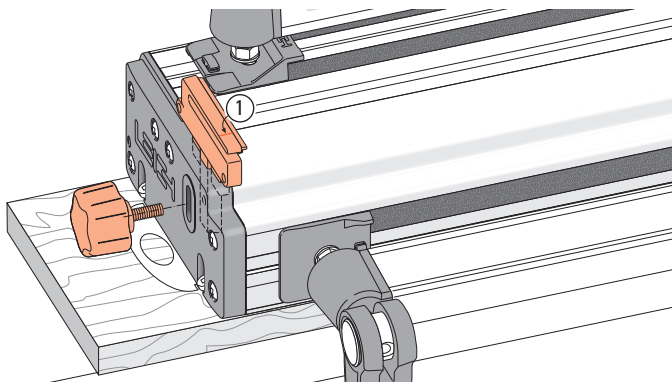

1-11 Insert the right and left support brackets. Attach the knobs, raise them to full height and tighten the knobs.
Note: For clarity, the set lines on support brackets are shown in red in this user guide. The actual bracket lines are black.

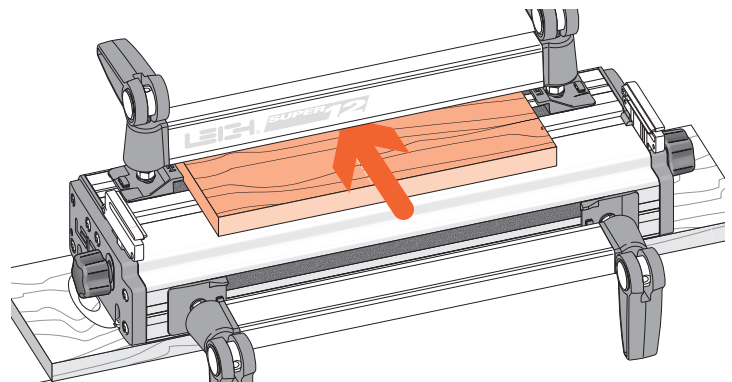

1-12 Make up a $\frac{3}{4}$ " x 6" [20 x 150mm] finger support board as shown. Lengths: 11" [280mm] for Super12, 17" [430mm] for Super18, and 23" [600mm] for Super24. Use MDF or plywood for flatness and stability. This board will support the guidefinger assembly in all front-clamping vertical board modes. Clamp it in the rear of the jig.

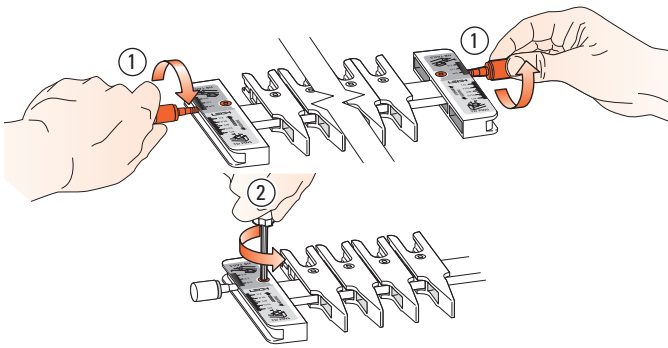
IMPORTANT

1-13 Before using the jig, the scales must be set into position on the finger assembly. Install the two thumbscrews a few turns into the scales ①. Loosen the scale lock screw ② at each end by one turn only.

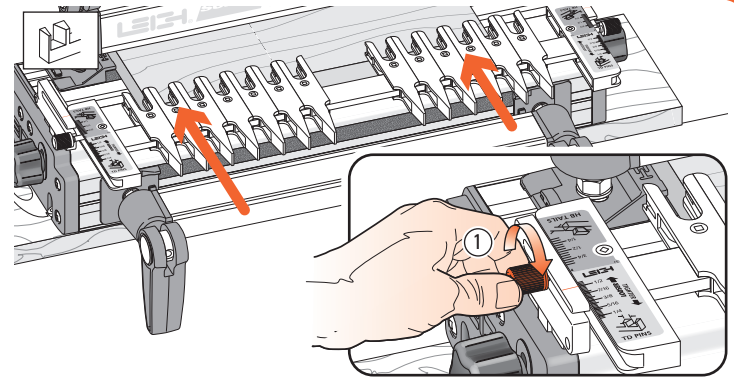

1-14 Slide the finger assembly onto the support brackets, in the TD Pin mode and set on the 1/2" [12,7mm] setting. First, tighten both thumbscrews ①. Do not lower the assembly onto the finger support board.

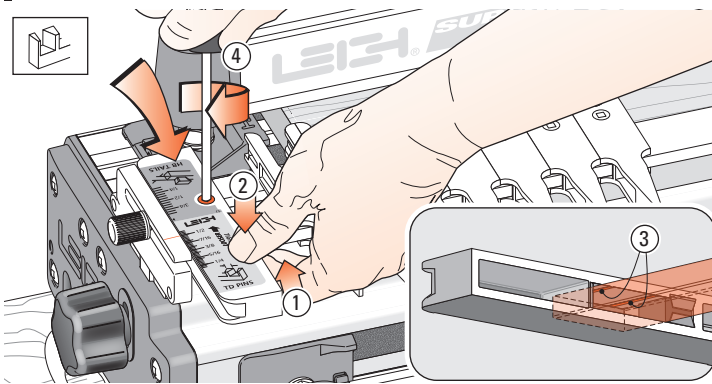

1-15 Pull up on the finger bar ① while pushing down on the scale ② to ensure the bar is touching the two registration pads ③ inside the scale. Maintain pressure and tighten the scale lock screw ④. Repeat at the other end. To maintain correct finger assembly alignment, follow this procedure whenever you remove the scales from the finger assembly.

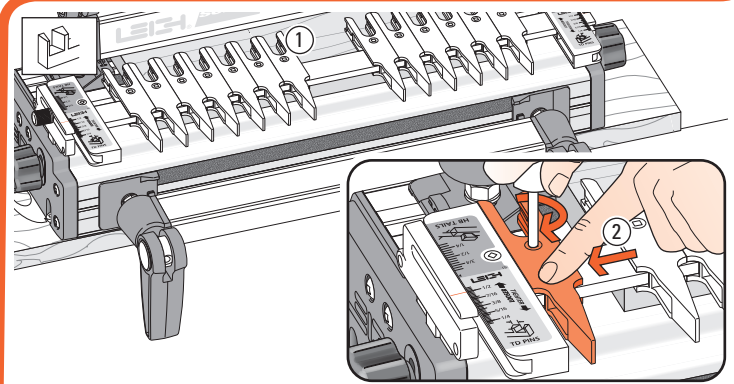

1-16 With the finger assembly in TD Pins mode ①, move the outer end guidefingers to touch the scale block and lock in position ②. *Note: the outer end guidefingers are used for router support only.* When guidefingers are loosened, the finger assembly should easily slide on the support brackets. If not, apply a little candle wax to the mating surfaces.

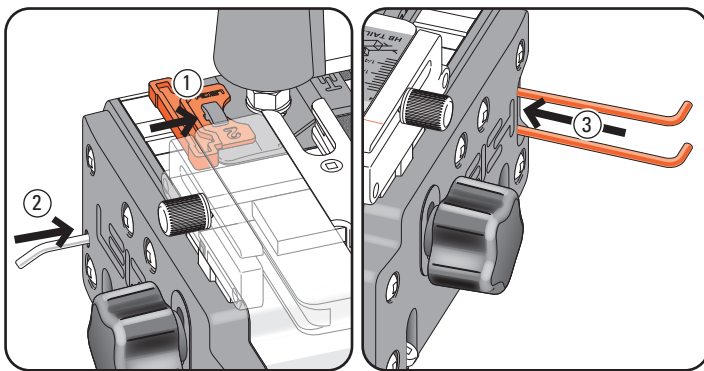

1-17 Finally, slip the Spacer on the outside of the left rear side stop ①, the nylon stop rod through its storage hole in the left end ② and the pin wrench in its slot in the right hand end housing ③.

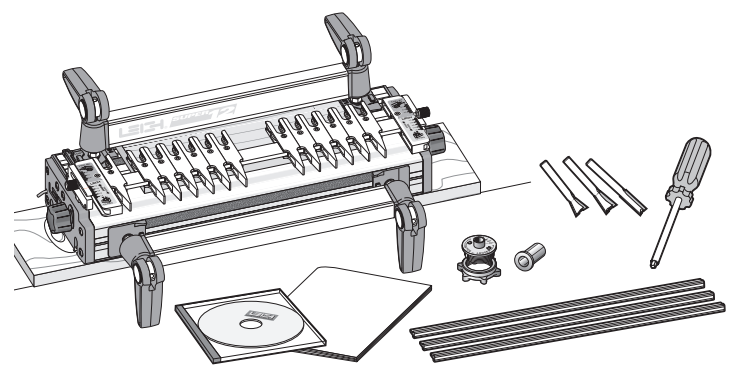

1-18 With Superjig assembled and mounted, you have some items left over:

- | | |
|--|------------------------------------|
| 1 Leigh jig user guide | 1 Straight bit |
| 1 DVD instruction video (English only) | 1 Collet Reducer |
| 1 Leigh e7-Bush and nut | 1 square-head screwdriver |
| 2 Dovetail bits | 3 bridge-piece/crosscut extrusions |

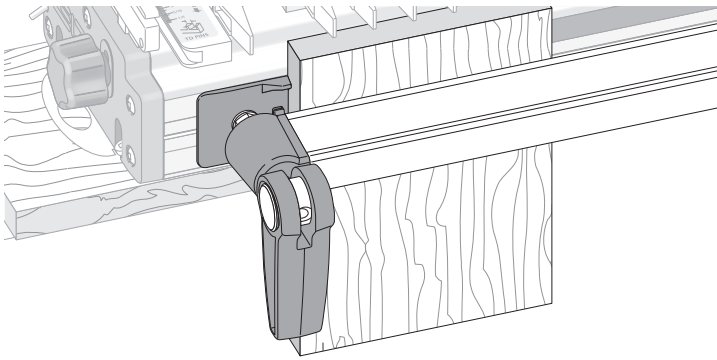

1-19 The Jig Clamps Use a piece of flat, even-thickness wood to familiarize yourself with the jig cam clamps. You will operate the cam-action speed clamps every time you use the jig, so get used to the feel of the clamps first. **Do not force the cam-action speed-clamp.** It has great leverage, and excessive force may damage the workpiece or the jig.

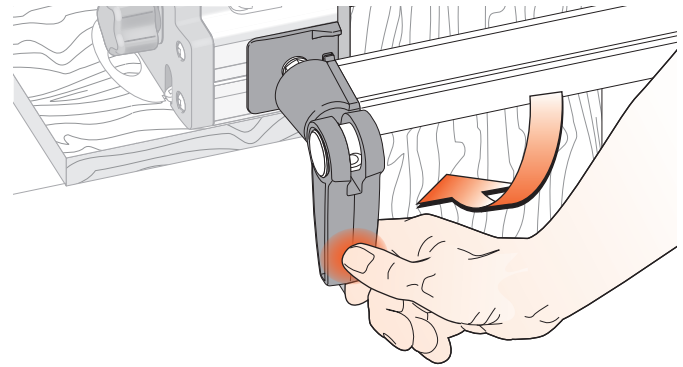

1-20 A smooth, firm action is enough to engage the clamp. Rule of thumb: If you can't throw the lever by pressing the end of it firmly with your thumb, reduce the tension. **Firm thumb pressure is about right.** A few minutes of trial and error will help you feel the right clamp tension.

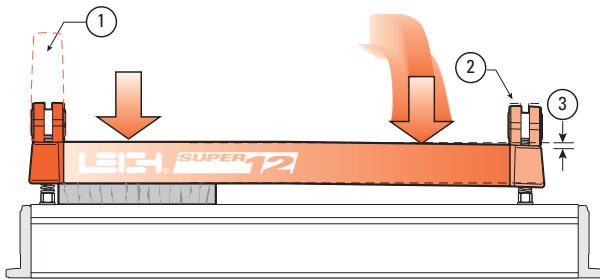

1-21 For all but the wider workpieces, you need only operate the clamp on the workpiece end of the jig to release the board ①. For narrower boards, the clamp at the free end ② should be just tight enough to bow the clamp bar about $\frac{1}{16}$ " [2mm] ③.

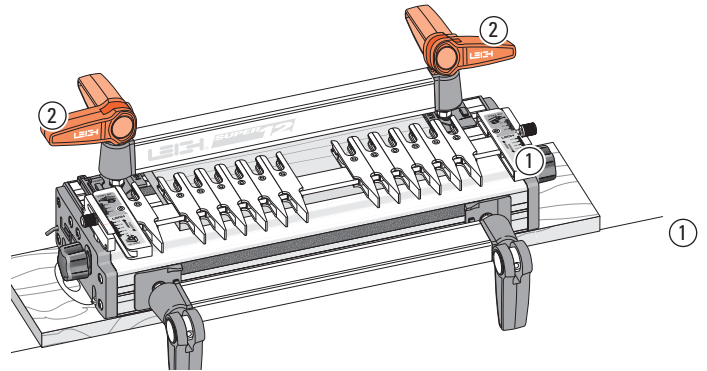

1-22 When engaged, the front clamp levers should normally point down and the rear levers should point away from the operator ① or up to 90° either side ② as required to obtain the optimum clamping pressure.

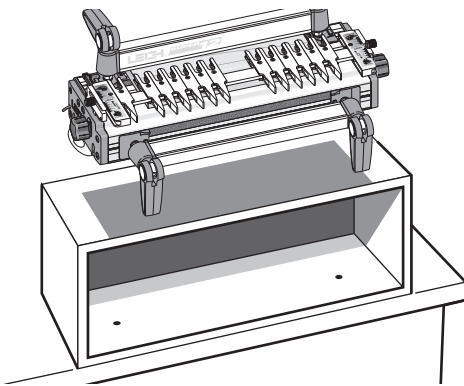

1-23 To gain height for a more comfortable working position or for routing longer boards, mount the jig to a box that can be bolted securely to a bench.

See also 15-13. ■

SUPERJIG - CHAPTER 2

Adjusting the Finger Assembly

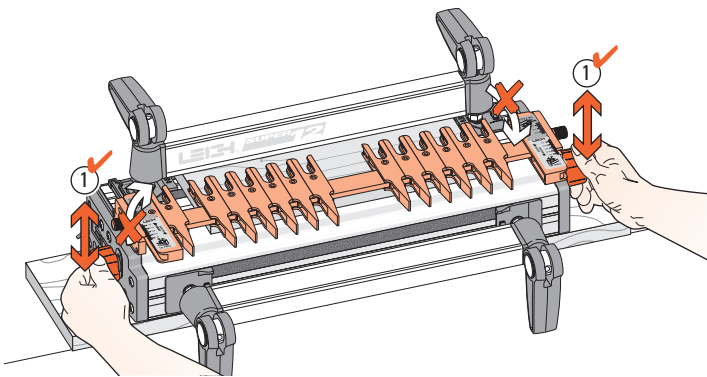

2-1 Practice with the finger assembly height adjustment. Loosen the support bracket knobs and hold them firmly. Raise and lower the assembly evenly, **keeping it level** ①, and tighten the knobs to lock it at various heights. **Do not raise or lower only one end of the finger assembly.**

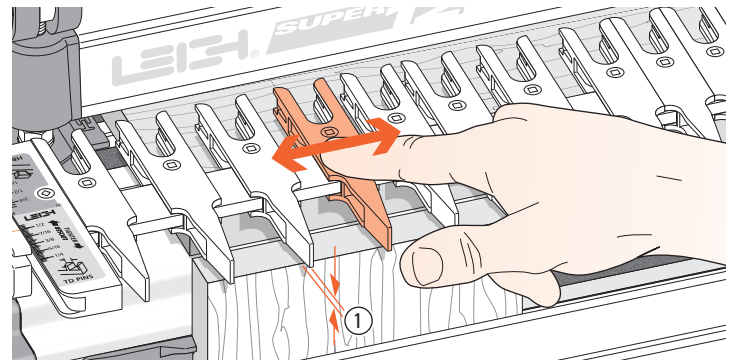

2-2 To practice adjusting the guidefingers, put a board in the front clamp. **Always raise the finger assembly slightly, approximately 1/16" [2mm] above the spacer board and/or workpiece** ①. This is essential to allow the guidefingers to move freely on the guidefinger bar and ensures that the fingers will be level and flush when locked up. Move the guidefingers by pushing on the middle to slide them along the guidefinger bar.

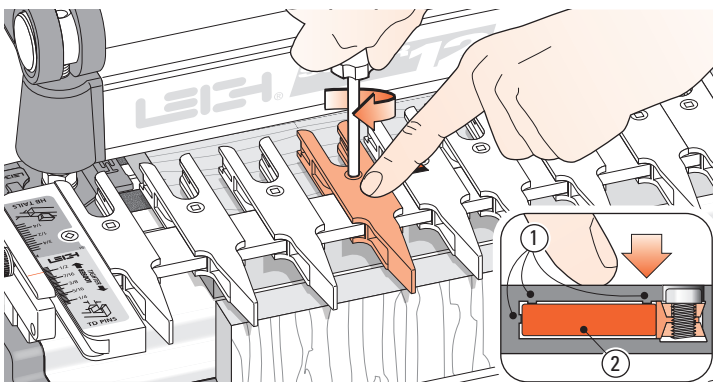

2-3 Loosen about half the guidefingers and practice unlocking, moving, positioning and re-locking them. **Always press on the center of the guidefinger when tightening the screws.** This ensures that the small pads ① on the inside of the finger contact the face of the finger bar ② and keeps all the fingers level.

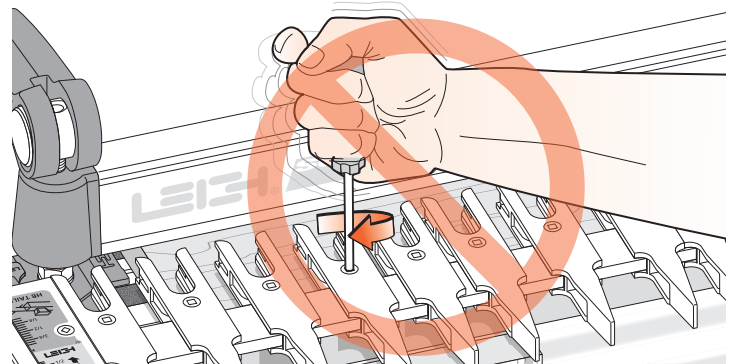

2-4 Do not over-tighten the guidefinger lock screws. The Leigh screwdriver provided will give ample torque for easy lock-up without strain.

Hint: Fingertip tighten a loose screw until the slightest resistance is felt. Do not tighten the screw more than half a turn (180°) from the first contact.

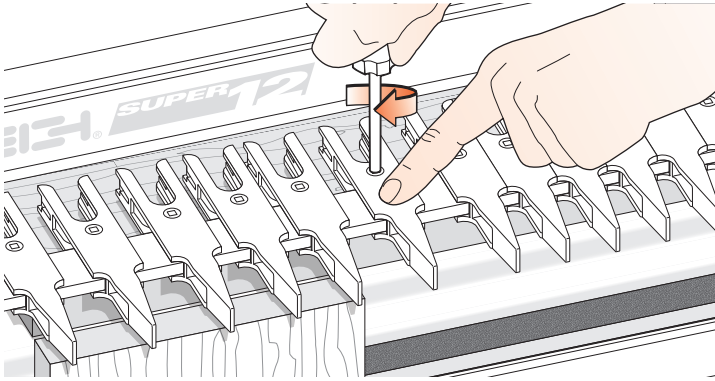

2-5 Always tighten unused guidefingers before routing, as router vibration may cause loose screws and finger lock parts to fall out and be lost.

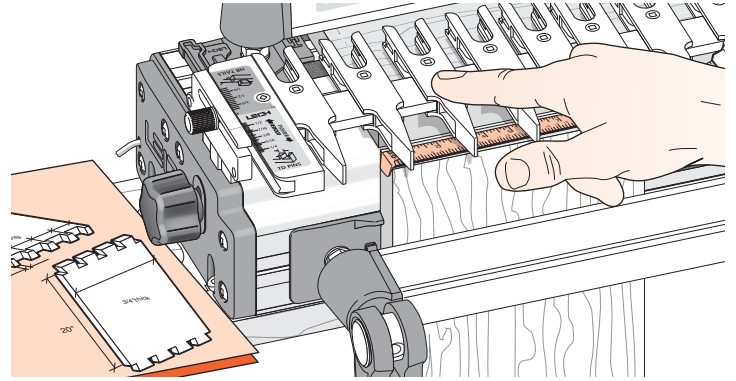

2-6 You can adjust the guidefingers by eye, or by measurement to suit a set of plans. ■

The Leigh e-Bush and Optional Guidebushes

The guidebush is the vital link between router and jig. All joints created on a Superjig are routed with the unique e7* elliptical guidebush, a Leigh innovation that provides precise joint fit adjustment for box joints and sliding dovetails. If your router doesn't accept the e7-Bush, you can use an alternative guidebush with some limitations.

*Supplied with each Superjig. U.S. Patent No. 8,256,475. UK Patent No. GB2443974. Patent Pending in Canada.

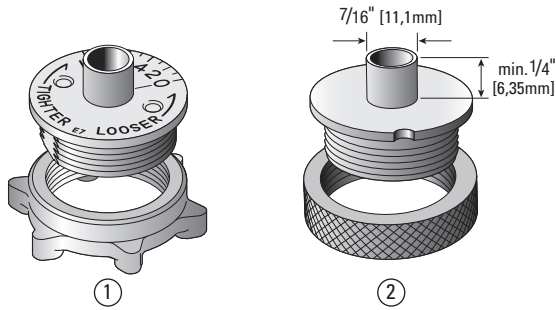

3-1 The Leigh e7-Bush ① is used to rout through, half-blind, single pass half-blind and sliding dovetails on a Superjig. The elliptical design provides precise joint fit adjustment for box joints and sliding dovetails. A round 7/16" [11,1mm] guidebush ② (min. barrel length 1/4" [6,35mm]), can be used to rout through, half-blind, and sliding dovetails on the Superjig, but the e7-Bush is superior.

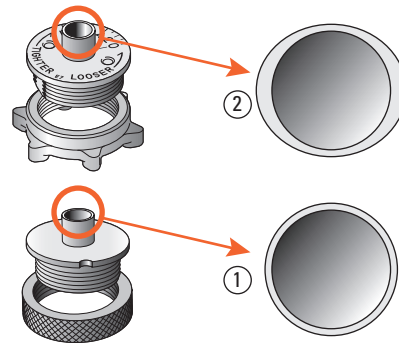

3-2 The Leigh e7-Bush that comes with your Superjig is a unique template guidebush that is adjustable in size. Unlike regular circular template guidebushes ①, the e7-Bush is slightly elliptical in cross section ②. This simple innovation effectively changes the guidebush "active diameter size" when it's rotated, and provides benefits not possible with a standard round guidebush.

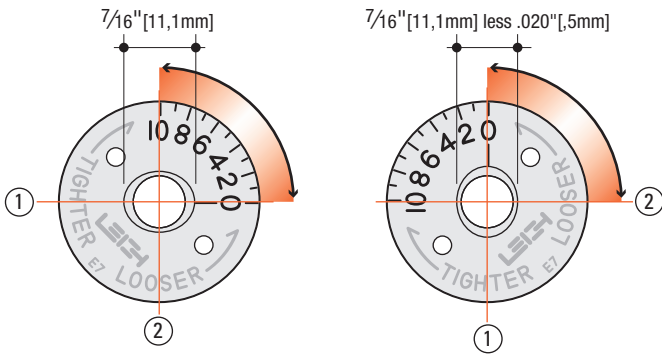

3-3 The e7-Bush (7/16") fits the router base or a guide bush adaptor in the base (see Appendix I). The ellipse/oval shape has a major axis ① 7/16" [11,1mm], and minor axis ② 7/16" [11,1mm] less .020" [5mm]. Turning the e-Bush 90 degrees in the router base changes the active diameter by .020" [5mm] providing minute adjustment and recordable settings for perfectly fitting box joints.

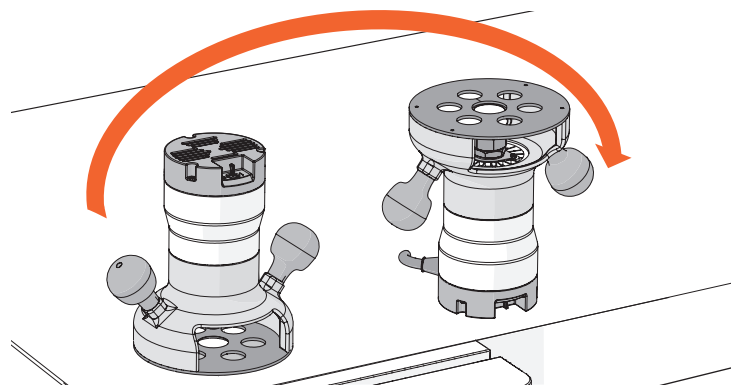

3-4 To install the e7-Bush, follow these simple steps. Hold the router the way you normally hold and operate it on the jig. Now, up end the router in the same orientation.

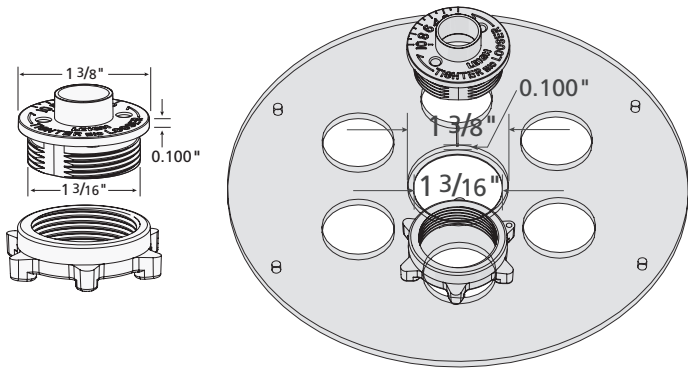

3-5 To fit the Leigh e-Bush directly to your router, the router base must have a 1-3/8" diameter counter bore. If your router base does not have the correct counter bore, you will need a guide bush adaptor or aftermarket router base plate. Leigh offers several guide bush adaptors to fit many common routers. See the Guide Bush Adaptor Selection Chart in Appendix 1, page 68.

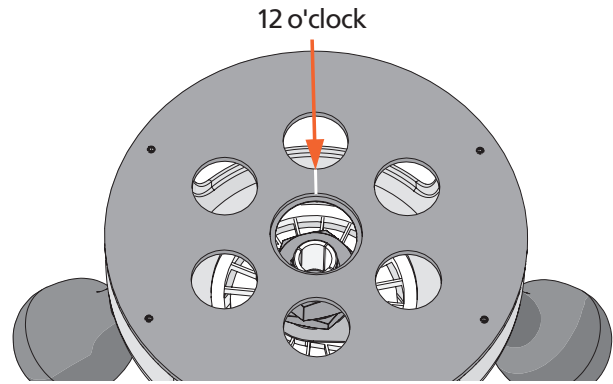

3-6 Think of the router base as a clock face. Make a small scratch line or permanent ink mark on the router base or e-Bush adaptor at the 12 o'clock position ①. This will be your reference mark for all e7-Bush settings.

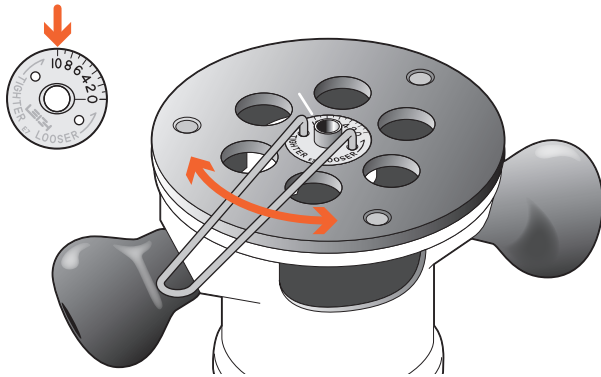

3-7 Use the pin wrench to align the No. 10 on the e-Bush to the reference line on the router base. The No.10 setting is used for all through and variably spaced half-blind dovetails on Superjigs. Settings for single pass half-blinds, box joints and sliding dovetails are described in applicable chapters. **Be sure to retighten the e-Bush nut after each adjustment.**

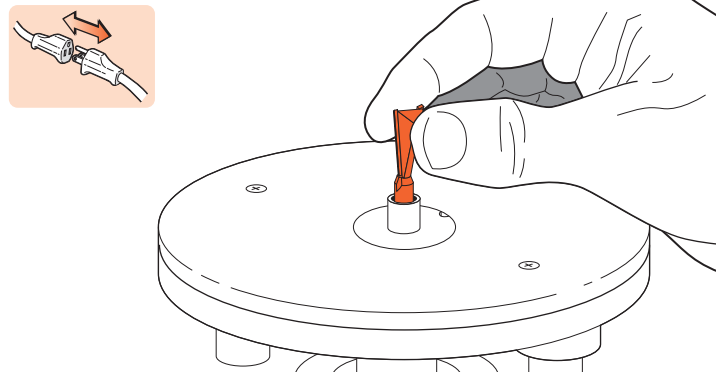

3-8 The bit goes through the guidebush and fits in the router collet or chuck.

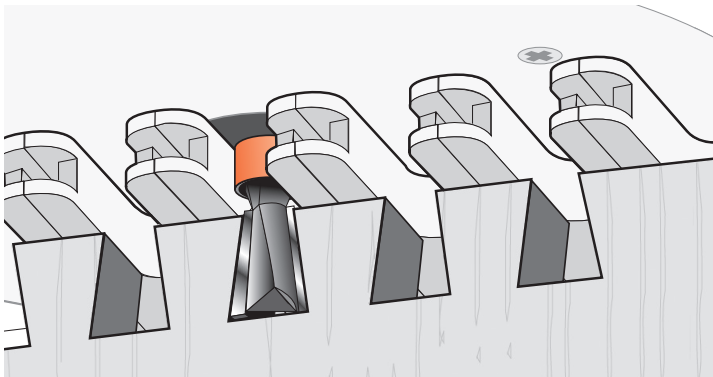

3-9 The projecting part of the guidebush runs along the side edge of the guide finger. The rotating bit cuts the wood only, and touches neither the guidebush nor the guide surface. ■

Basic Jig Functions and Scale Modes

Here are the basics for understanding the different Superjig dovetail modes and settings.

THE FOUR SCALE MODES

The Finger Assembly attaches to the support brackets in four different modes to match the type of joint you are cutting.

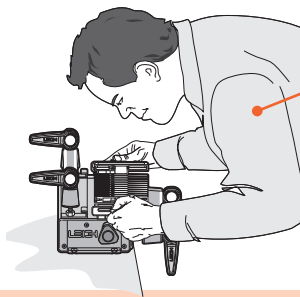

Reading scales from directly above helps sight the lines accurately.

This line is for the finger assembly scales. The line is illustrated in red for clarity in this user guide, but is black on the jig.

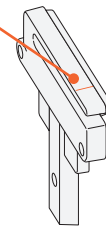

Note: Inch scales are shown here. Millimeter scales have similar layouts.

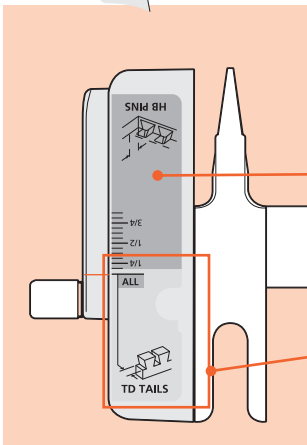

The inactive scale is always on the rear of each scale assembly and is upside-down.

The active scale is always on the front of each scale assembly.

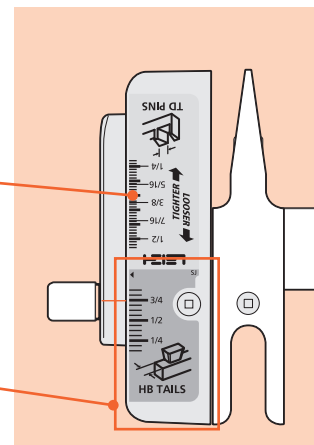

1. TD TAILS

3. HB TAILS

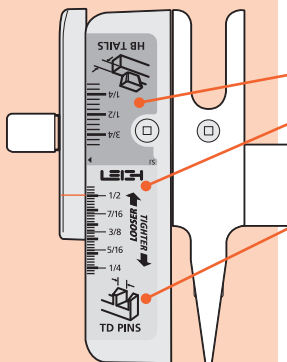

Scales are color coded.

- Green: Half-Blind Dovetails.
- Silver: Through Dovetails.

Each scale has its own mode icon (a drawing of the joint part made in that mode).

The specific settings for each scale are fully described in the appropriate chapters.

2. TD PINS

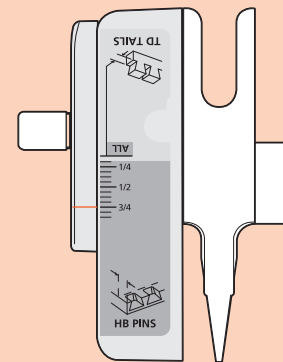

4. HB PINS

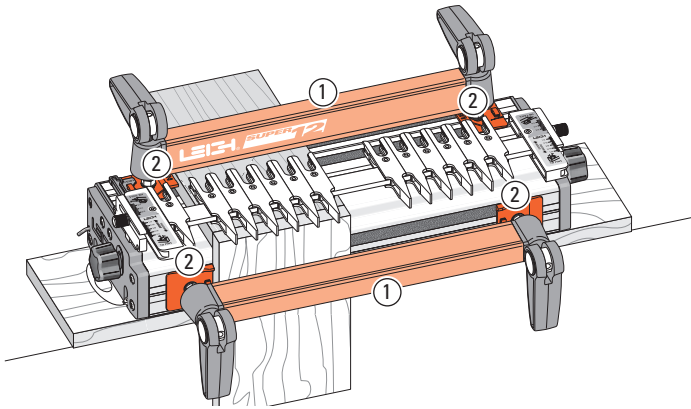

4-1 The two clamp bars ① hold workpieces horizontally or vertically. The side stops ② align the boards in the correct position each time.

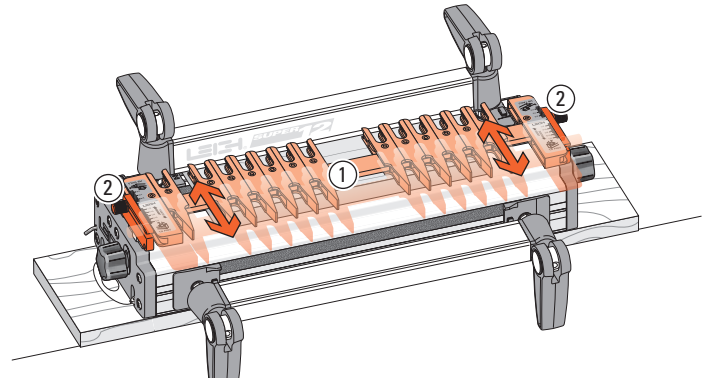

4-2 The guidefinger assembly slides in the support brackets above the workpiece. The finger assembly is adjusted in or out using calibrated scales on each end to suit different thicknesses of vertical boards.

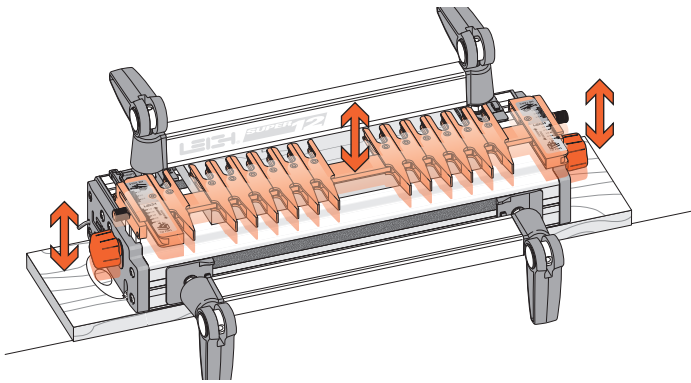

4-3 The finger assembly is raised or lowered using the support brackets to suit different thicknesses of horizontal boards. ■

SUPERJIG - CHAPTER 5

Using Your Jig Safely

Safety is not optional.

Read and follow the recommendations in this chapter.

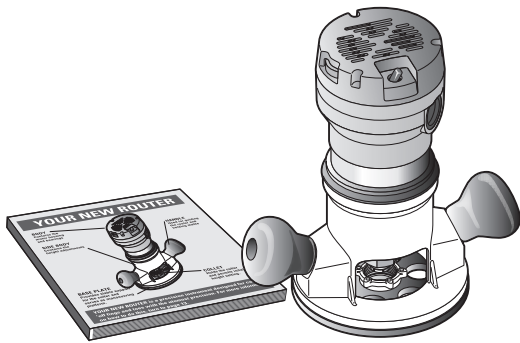

5-1 Read the user guide that came with your router. It is essential to understand the router manufacturer's instructions completely. Always operate variable speed routers at the fastest possible speed.



5-2 Always wear approved safety glasses. Always wear hearing protection. Protect yourself from harmful dust with a face mask. For complete comfort and convenience, get yourself a Leigh VRS (Vacuum & Router Support) to match your jig model.



5-3  Never drink alcohol or take medications that may cause drowsiness when you will be operating a router.

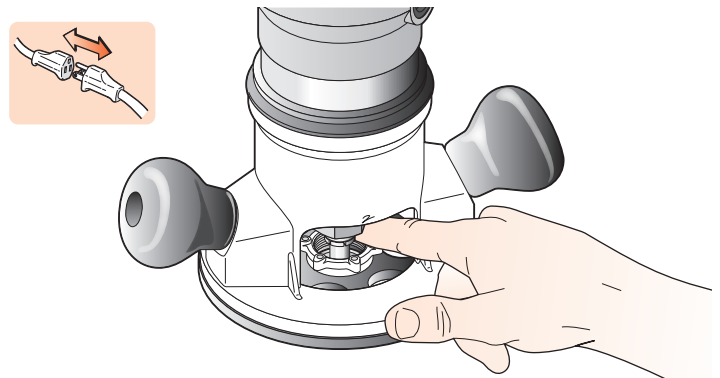

5-4 Always disconnect the power source from the router when fitting bits or guidebushes, or making adjustments. Before connecting the router to the power source, make sure the bit and collet revolve freely in all the areas you plan to rout, and the bit does not touch the guidebush or jig.

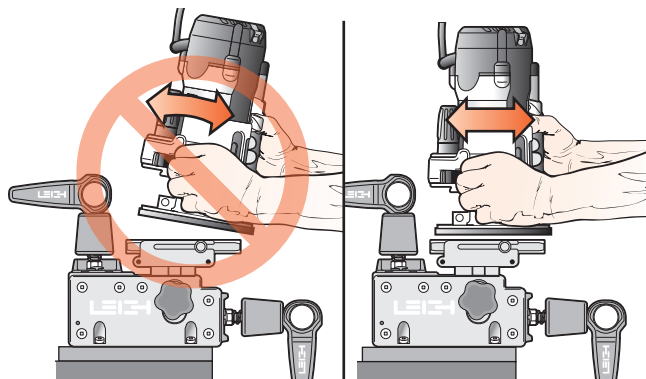

5-5 Do not tilt the router on the jig. Keep the router flat on the jig assembly.
Note: The optional Leigh VRS attachment prevents router tilting.

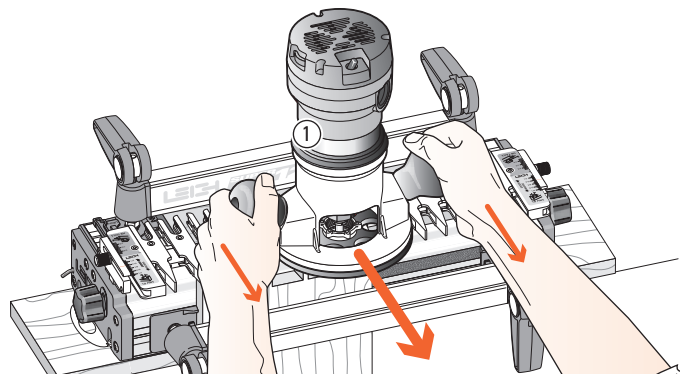

5-6 If you insist on removing the router from the jig while it is still revolving, always pull it straight off the jig horizontally, and do not raise or lower the router until it is completely clear of the jig.

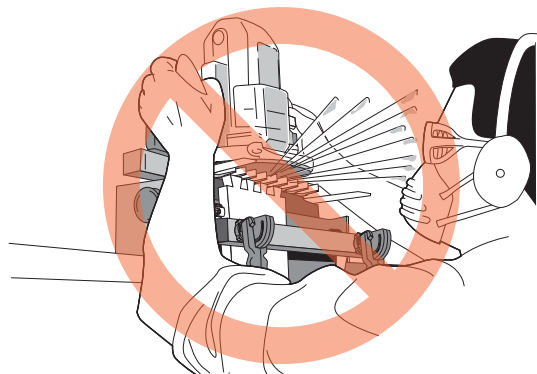

5-7 Do not rout at face level.

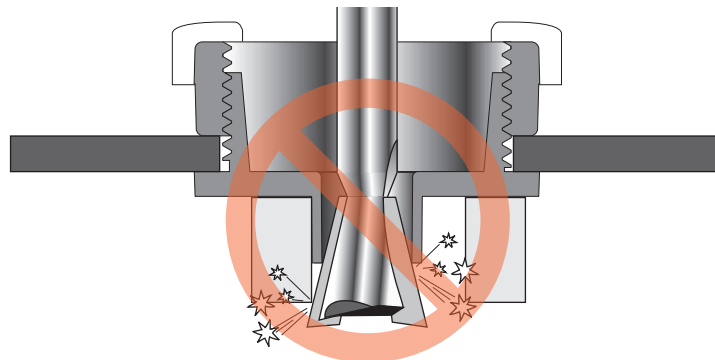

5-8 Never release the router plunge mechanism when using dovetail bits. Check if your plunge router has a stop nut to prevent this from happening accidentally.

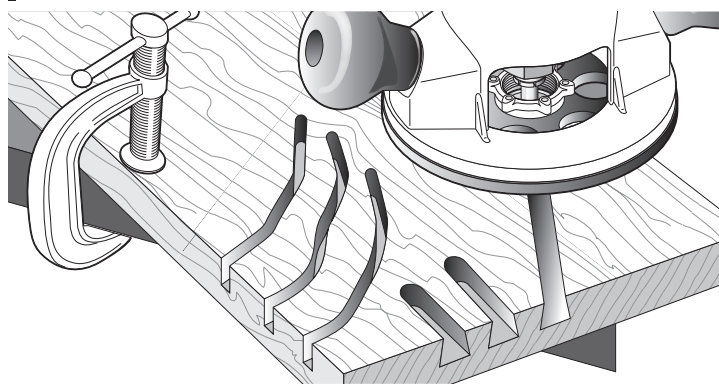

5-9 If you have never used your router before, be sure to follow the router manufacturer's instructions for its use. Make plenty of simple open-face practice cuts *without a guidebush* before you try to use the router on the Leigh jig. You must, of course, always use a guidebush when routing on the Leigh Jig. ■

SUPERJIG - CHAPTER 6

Wood Preparation

"Garbage In - Garbage Out"...

This adage of the computer age stands equally true for dovetail jigs.

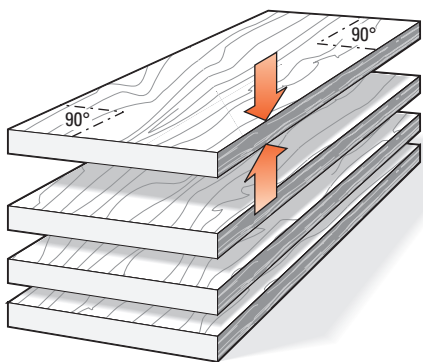

6-1 It is vital for accurately aligned joints that stock used on the Superjig should be prepared straight, flat, of even thickness and equal widths, with square ends and edges. *Note that plywood is generally unsuitable for routing because of tearout problems.*

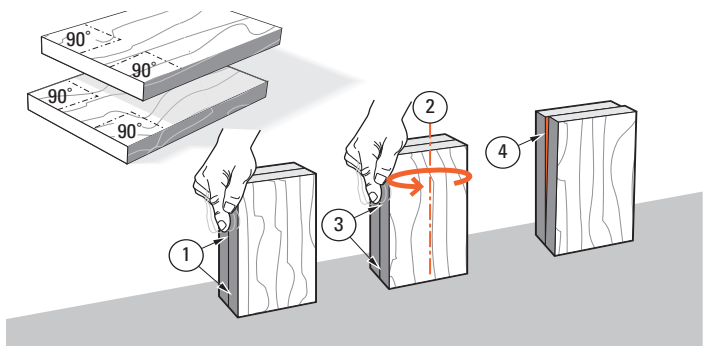

6-2 ⚠ Check for squareness: stand both pieces vertically on a flat surface. Make sure side edges are flush at bottom and top ①. Turn one piece around on its end ②. If side edges are flush top to bottom ③, the boards are square. If not, ④; cut two that are.

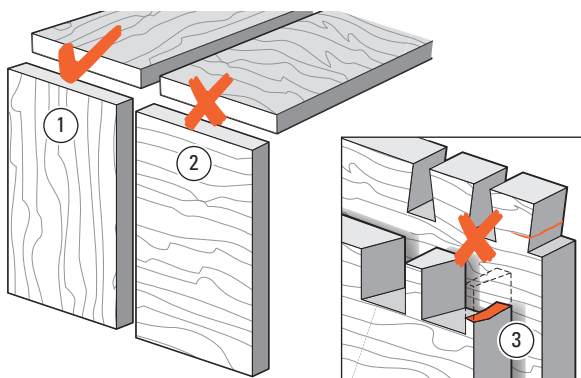

6-3 ⚠ Dovetail joints are intended for joining end-grain to end-grain ①. Attempting to rout dovetails in side grain ② will not work because:

- A. The wood will tear out badly when routing.
- B. The pins and tails will easily break off across the short grain ③, either during or soon after assembly, when the boards start expanding and contracting at different rates.

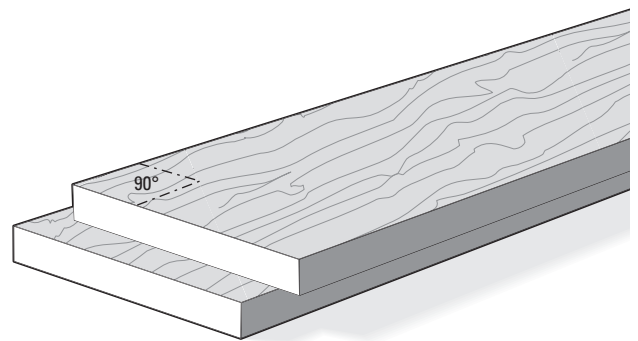

6-4 You will want to test the jig, so prepare some $\frac{3}{4}$ " x $5\frac{1}{2}$ " [20x140mm] boards. Cut them to length as you need them for the jig tests you want to perform. Use them for practice with the jig's various joint modes so you can see how the different modes work. **Remember, though, that two boards of different thicknesses can be joined just as easily.**

SUPERJIG - CHAPTER 7

Router Preparation

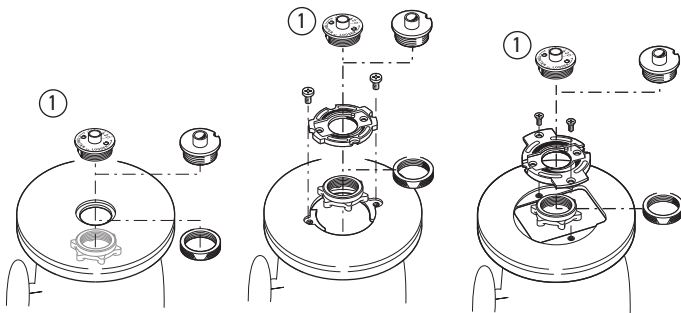

7-1 Fit the e7-Bush ①. One is included with your Super Jig. Some guidebush adaptors may have to be modified to allow adjustment rotation of the e7-Bush in the base. *See page 67.* If the e-Bush is incompatible with your router, any $\frac{7}{16}$ " [11,1mm] guidebush (min. depth $\frac{1}{4}$ " see page 67) will work for all but box joints on the Superjig.

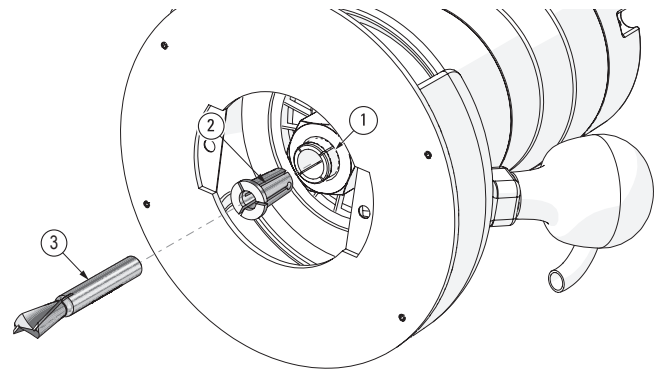

7-2 Routers used on Super Jigs must have a $\frac{1}{2}$ " or 8mm collet ①. All Super Jig bits have 8mm shanks. Routers with $\frac{1}{2}$ " collets must use the $\frac{1}{2}$ " to 8mm collet reducer ② supplied with the jig. The collet reducer ② is inserted in the router collet ① (chuck) and the 8mm shank bit ③ is inserted in the collet reducer. Routers with 8mm collets do not require a collet reducer.

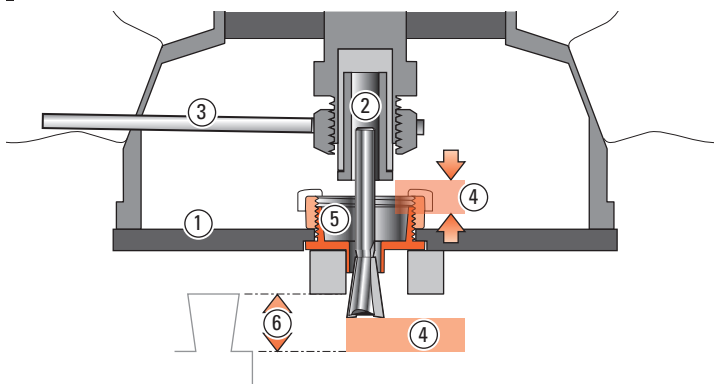

7-3 When fitting a bit to the router ①, fit the shank as far into the collet ② as possible. Always rout with the collet as close to the guidebush as possible. Usually you can't securely grip the collet nut with a wrench ③ if the collet is at its optimum low position. Fit the bit so that the remaining travel ④ between collet and guidebush ⑤ will let the bit reach the required depth of cut ⑥.

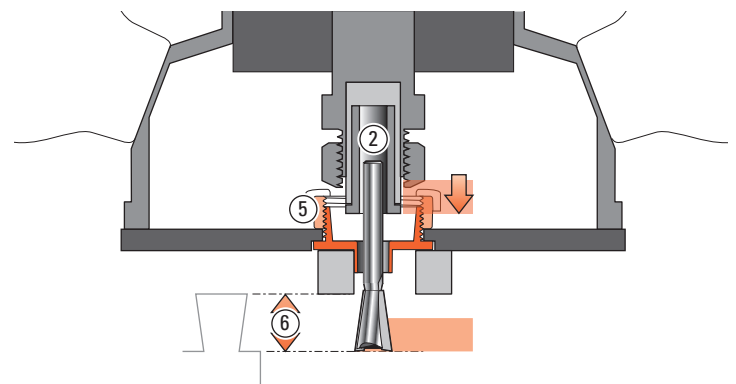

7-4 Tighten the collet ② securely and lower the collet to adjust the depth of cut ⑥, but make sure the collet does not contact the guidebush ⑤.

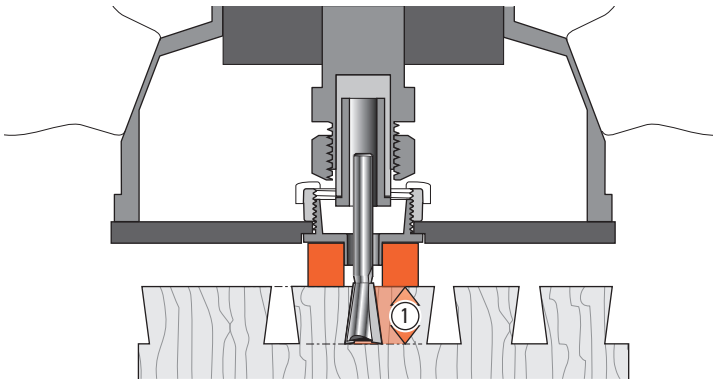

7-5 Depth of Cut: The depth of cut always refers to the actual depth of the cut into the wood beneath the guidefingers ①.

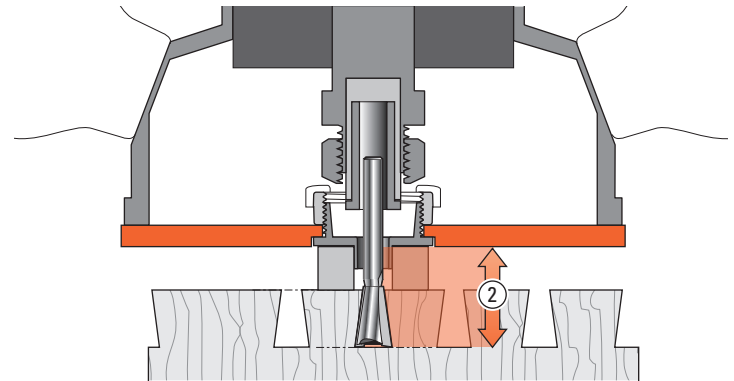

7-6 Depth of cut is **not** the distance the bit projects from the router base. This is **bit projection** ②. This user guide generally refers to depth of cut. Bit projection ② is always .500" [12,7mm] more than depth of cut.

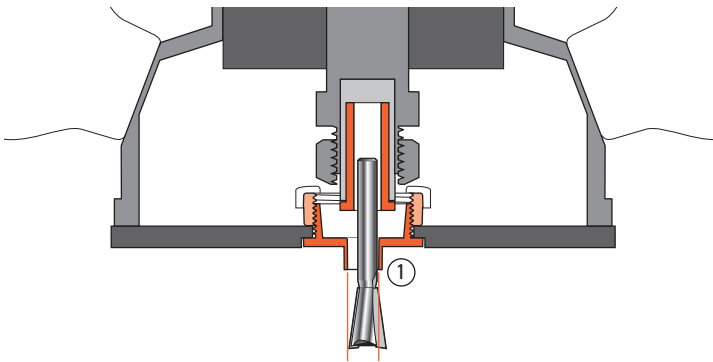

7-7 Ideally, the router collet (and bit) should be concentric (centered) to the guidebush as in figure 7-5. Regrettably, this is often not the case; the bit can be off center (eccentric to) the guidebush ①. The illustration shows the problem highly exaggerated. The good news: bit to bush alignment doesn't affect joint fit or flushness; both are "adjusted out" in normal jig setup.

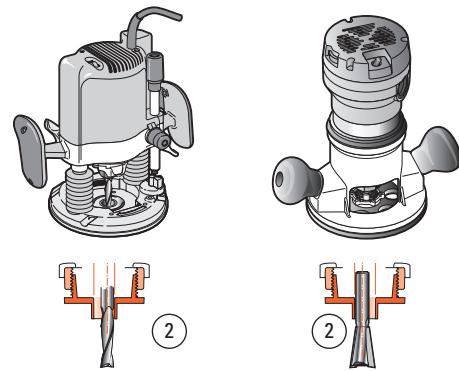

7-8 Bit to guidebush offset may change when the router motor is unclamped from the base when changing bits or making bit height adjustments. Concentricity problems can also arise if two routers are used for through dovetails, (one for pins; one for tails). Routers with different bit to guidebush offsets ② (misalignment shown highly exaggerated)...

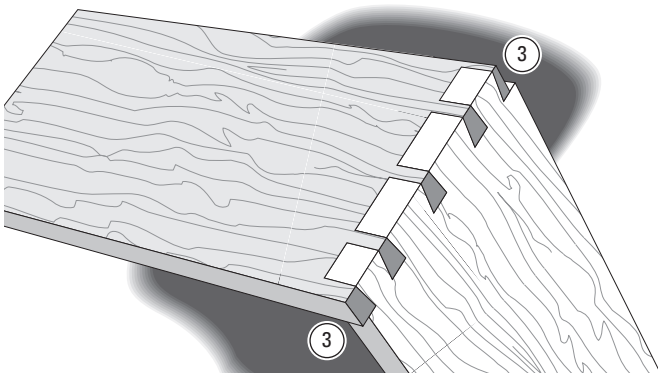

7-9 ...will cause pin to tailboard ③ misalignment (again, shown highly exaggerated).

Fortunately, some newer routers have sub-bases that can adjust for concentricity. If you don't have this type, it might pay to stick to a single router for through dovetails. ■

Through Dovetail Procedures

In these instructions for using the Leigh Superjig dovetail Jig, we recommend using certain bits and board sizes just because they are easy to work with. When you have cut some practice joints and gained confidence in your ability to get the results you want, feel free to use the bit selection charts on the following page and in Appendix II, to plan whatever dovetail routing you need for your projects.

Concept of Jig Operation – THROUGH DOVETAILS

All Super Jig Through Dovetail tail bits have an 8° angle. This angle matches the 8° angle cast into the pin end of each guide finger. Start with the Finger Assembly in the TD TAIL mode and follow these steps on your jig. Grasping the simple basic concept of operation will now greatly assist you in understanding the instructions. Note that the active guide surface (against which the guidebush runs) is indicated in red in these illustrations. Note: The e7 eBush is always set to 10 for through dovetail routing.

1 Start in Through Dovetail Tails (TD TAILS) mode

MODE ICONS

Illustrations in this user guide include the correct mode icon for the current instruction. The icons are also used in the instruction text.

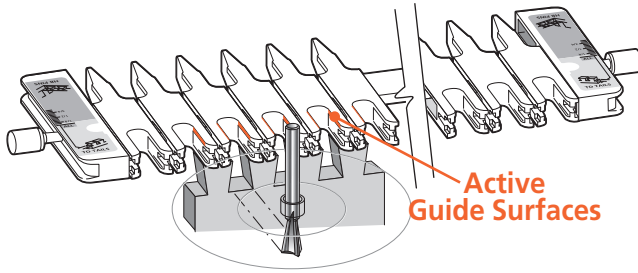
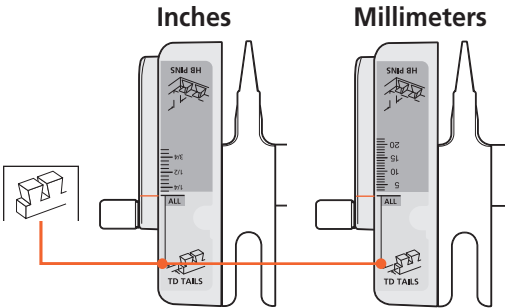

2 ROTATE the finger assembly toward you 180°

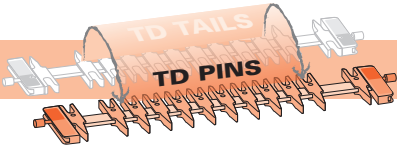

3 Now the Finger Assembly is in Through Dovetail Pins (TD PINS) mode

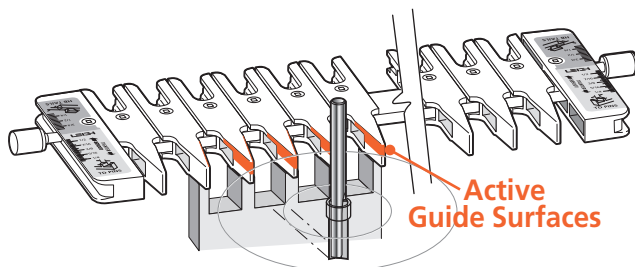
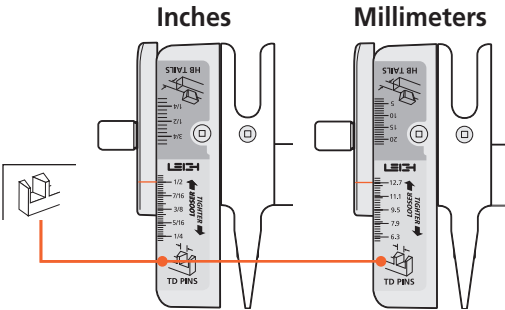

Through Dovetail Bit Selection

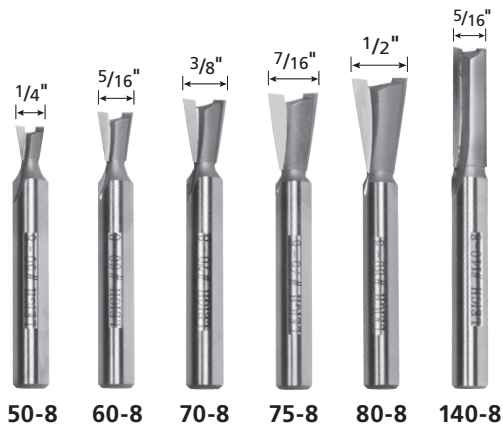

THROUGH DOVETAIL BIT CUTTING DEPTH						
All through dovetail bits have 8° angles. All carbide bit heights are slightly greater than maximum depth of cut listed.						
Bit No.	50-8	60-8	70-8	75-8	80-8	140
Depth of Cut	1/8"	[Diagram showing bit cutting into wood]				
	1/4"	[Diagram showing bit cutting into wood]				
	3/8"	[Diagram showing bit cutting into wood]				
	1/2"	[Diagram showing bit cutting into wood]				
	5/8"	[Diagram showing bit cutting into wood]				
3/4"	[Diagram showing bit cutting into wood]					
7/8"	[Diagram showing bit cutting into wood]					
1"	[Diagram showing bit cutting into wood]					

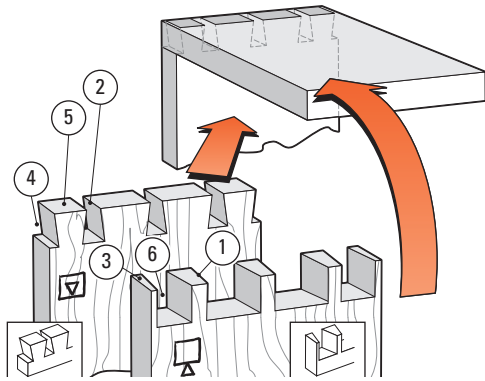

8-1 Through Dovetail Terminology:

- ① Pins
- ② Pin sockets
- ③ Half-pins
- ④ Half-pin sockets
- ⑤ Tails
- ⑥ Tail sockets

The pins fit in the pin sockets. Joints should almost always end each side with half-pins.

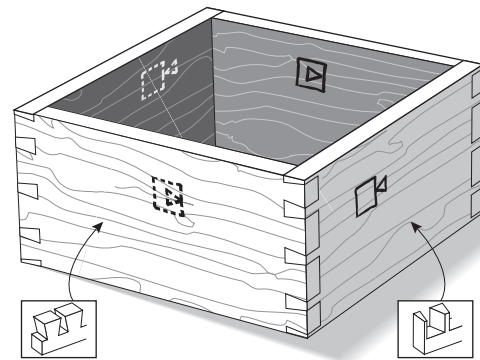

8-2 Let's look at how to make a simple square box. When you assemble the finished pieces with the faces properly oriented, then any one of the pin ends will fit any one of the tail ends. In fact, the box can be put together in six different ways.

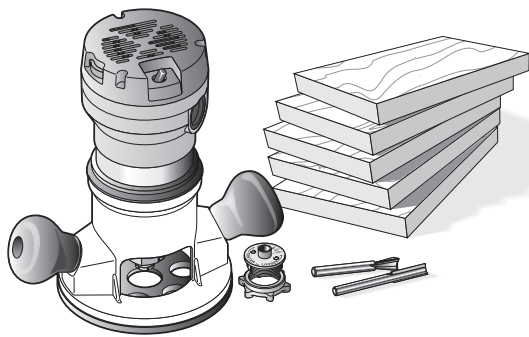

8-3 For this trial you need five identical boards $\frac{3}{4}$ " x $5\frac{1}{2}$ " [20x140mm] x about 8" [200mm] long. Mark inside faces for two tailboards and outside faces for three pinboards (one pinboard is a spare). Use the e7-Bush, the No. 80-8 $\frac{1}{2}$ " [12,7mm] x 8° dovetail bit and 140-8 $\frac{5}{16}$ " [7,9mm] straight bit (all included with Superjig).
Note: $\frac{13}{16}$ " [20mm] is maximum through pin board thickness.

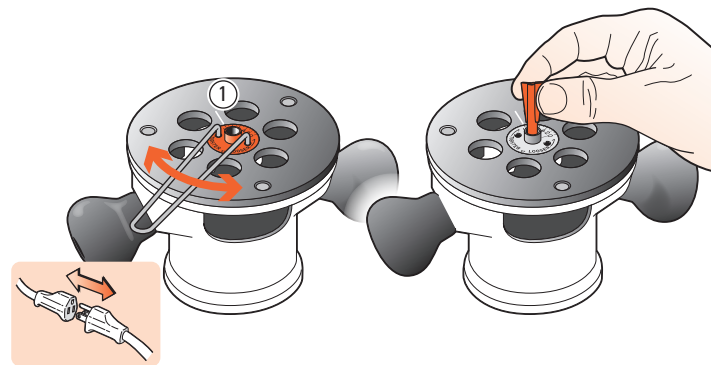

8-4 Fit the E-7 guidebush to the router. Align the No. 10 mark with the base mark ①. No guidebush adjustment is required with through dovetails. If you have a router that is incompatible with the e-Bush, you can use a standard $\frac{7}{16}$ " [11,1mm] guidebush (min. depth $\frac{1}{4}$ " see page 67) for through dovetails. Then fit the supplied 80-8 dovetail bit to the router.

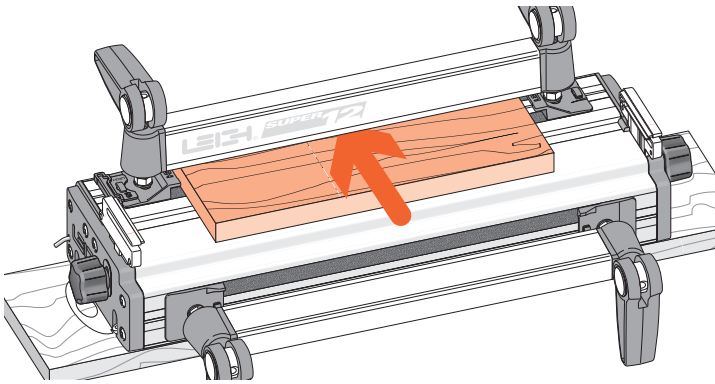

8-5 Clamp the finger support board in the rear clamp. See Chapter 1, section 1-12

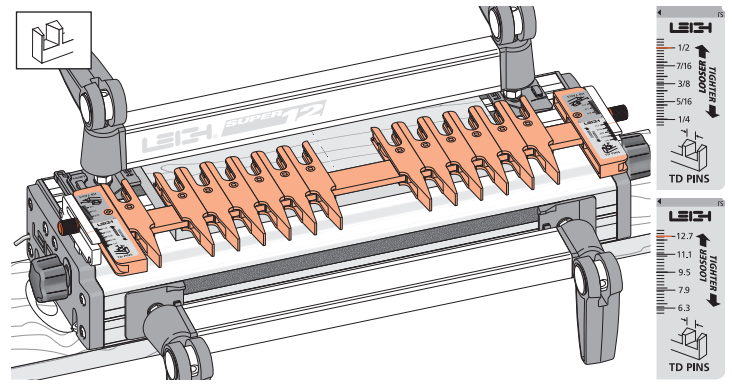

8-6 Place the finger assembly on the support brackets in the TD PINS mode, flat on the spacer board, and with the scale set on the $\frac{1}{2}$ " [12,7mm] setting for now. Don't worry about the scale's specific meaning now. Each scale's use will be fully explained in the appropriate section.

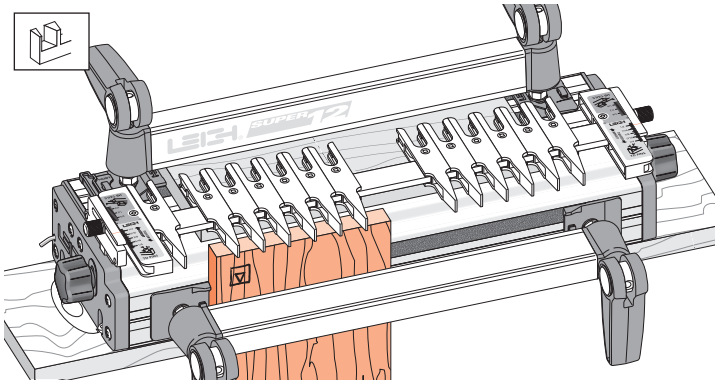

8-7 Clamp a tail board against the left front side stop, top edge touching flush under the guidefingers, inside face \square away from the jig body. Although you will cut tails first, adjust the guidefinger layout in TD PINS mode. The adjustment screws are on top in this mode, and it's easier to visualize the finished joint pattern.

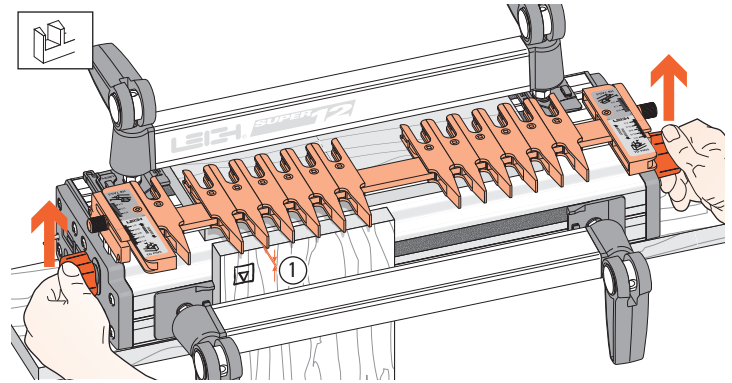

8-8 Loosen the support bracket knobs and raise the finger assembly about $\frac{1}{16}$ " [2mm] ① above the boards, then re-tighten the knobs. This will allow easy and accurate guidefinger adjustment.

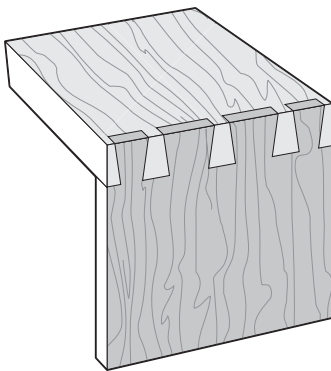

8-9 This joint layout is just a suggestion for this trial. It has a typical, traditional **symmetrical** pin layout, with half-pins at each edge. The Superjig however, allows for infinite dovetail spacing. Also, boards of different thicknesses can be joined to each other as shown in this illustration. Before attempting an **asymmetrical** joint layout, see chapter 12.

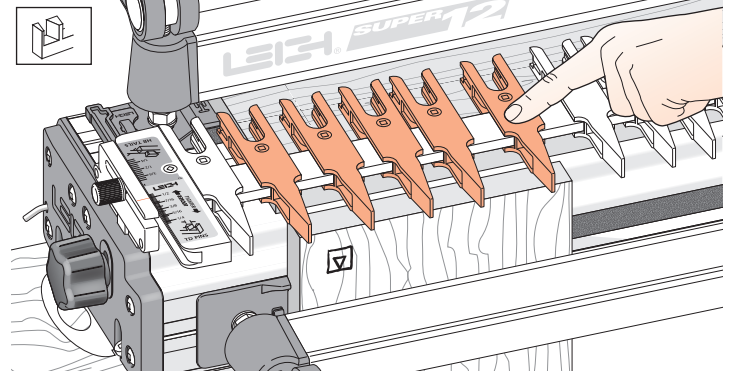

8-10 Ignoring the extreme outer guidefinger next to the scale (it just supports the router), loosen the next five guidefingers and slide them over the top of the workpiece.

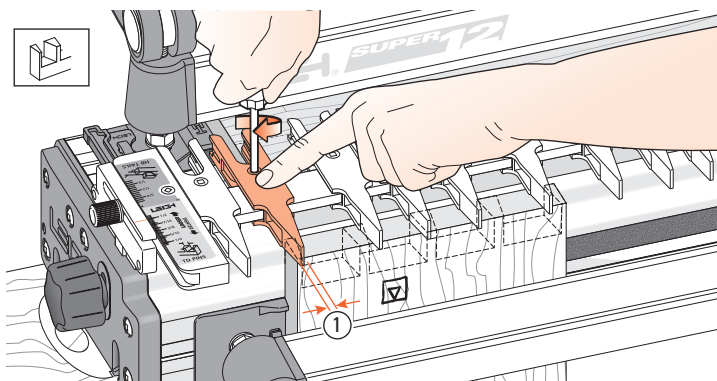

8-11 Lock the left-most guidefinger with its center-line about $\frac{1}{8}$ " [3mm] ① in from the left edge of the board to form a half-pin.

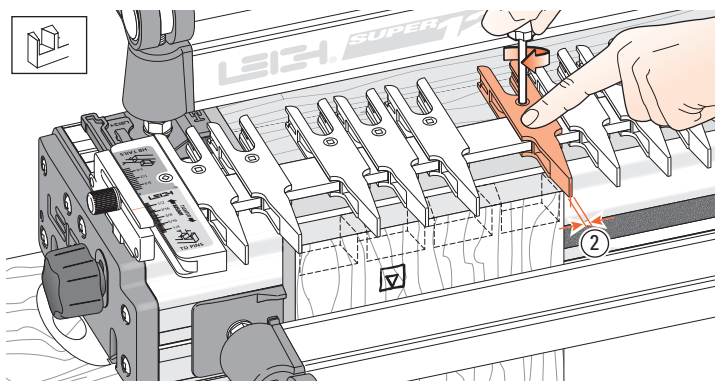

8-12 Leave three guidefingers over the board. Lock the right-most guidefinger with its center-line about $\frac{1}{8}$ " [3mm] ② in from the right edge of the board to form the other half-pin. Judge this distance by eye: it need not be exact. The sockets and pins will align automatically.

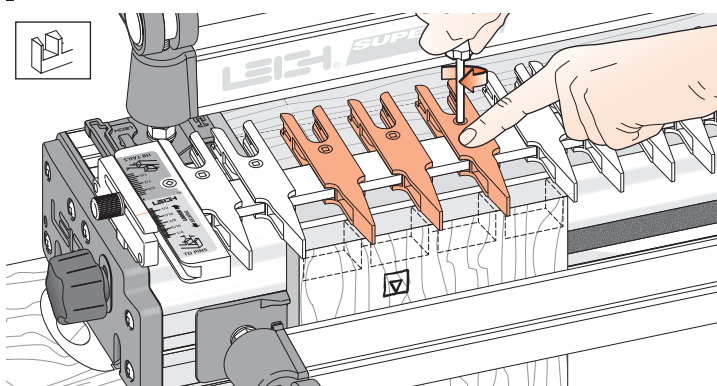

8-13 Space and lock the three remaining guidefingers as shown. Again, judge it by eye. If it looks right on the jig, the finished joint will look right.

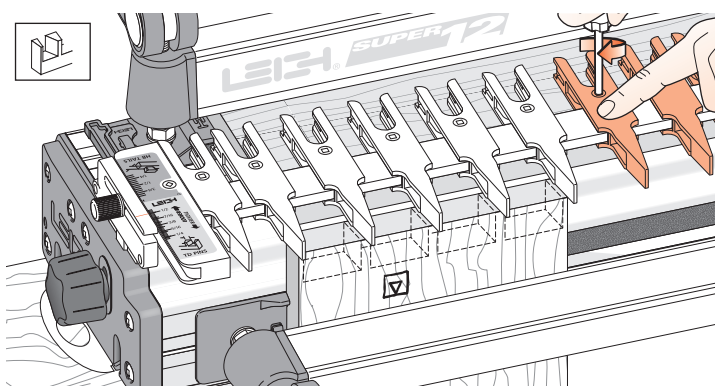

8-14 Tighten any other loose guidefingers.

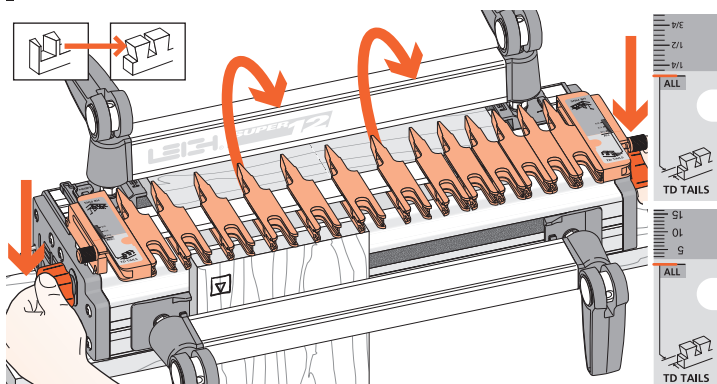

8-15 Rotate the finger assembly to  TD TAILS mode, and set it to the "ALL" position on the scale. Lower the finger assembly onto the spacer board. All TD tails are routed at this "ALL" setting. (This setting allows the dovetail bit to pass completely through all tail boards.)

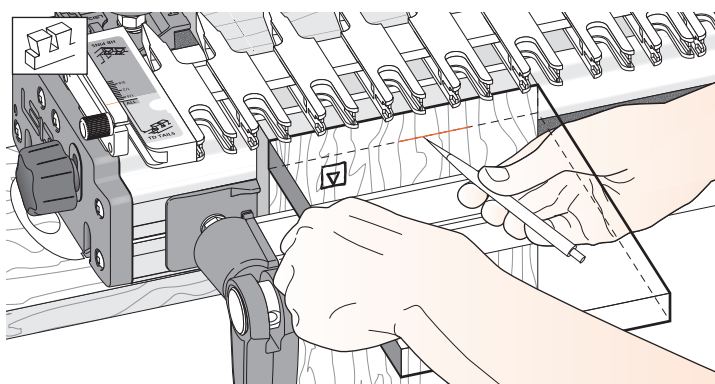

8-16 Place the end of a *pin board* horizontally flush under the guidefingers and mark a thin pencil line partly across the tail board.



REMEMBER SAFETY!

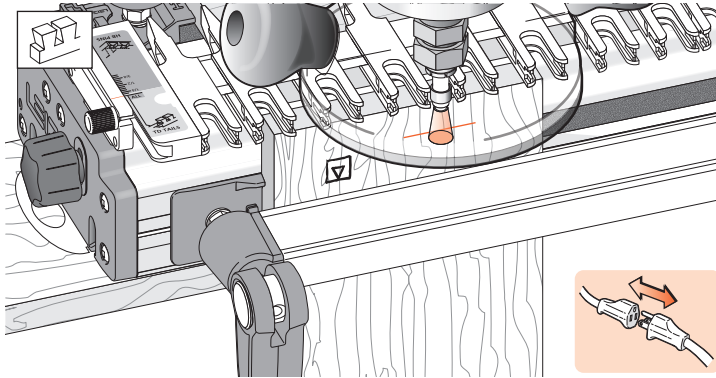

8-17 Place the router on the finger assembly and adjust the router until the dovetail bit tip is level with the center of the pencil line. *Note: This means the pin socket will be half a thin pencil line deeper than the thickness of the pin board, leaving minimal clean-up after assembly.* Check to make sure the bit rotates freely.

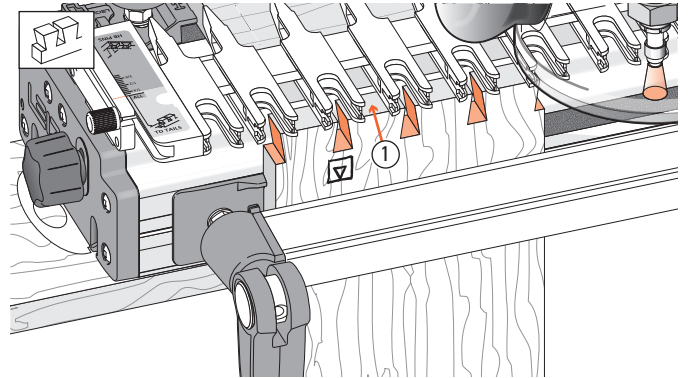

8-18 Plug in the router and rout out the half-pin and pin sockets. Use only light side pressure on the guide fingers. Make sure to run the guidebush along both sides of the finger opening. Take care not to rout unwanted sockets where there are gaps between pairs of fingers ①. Rout only between the rounded guidefinger tips. See Hints and Tips Chapter 15.

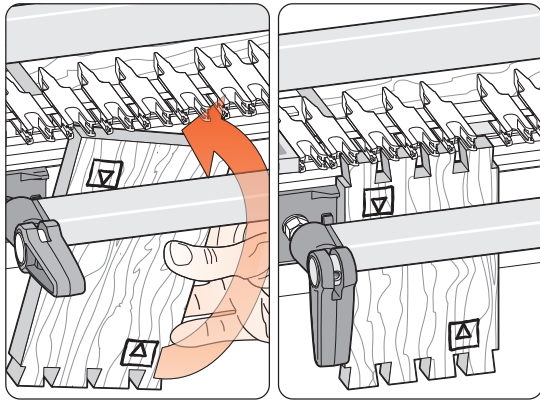

8-19 Before removing the routed board from the jig, check by eye and touch to make sure no parts have been missed. Release the clamp and reverse the tail board in the jig, keeping the same inside face ▽ away from the jig body. Rout the other end of this tail board and both ends of the second tail board in the same fashion.

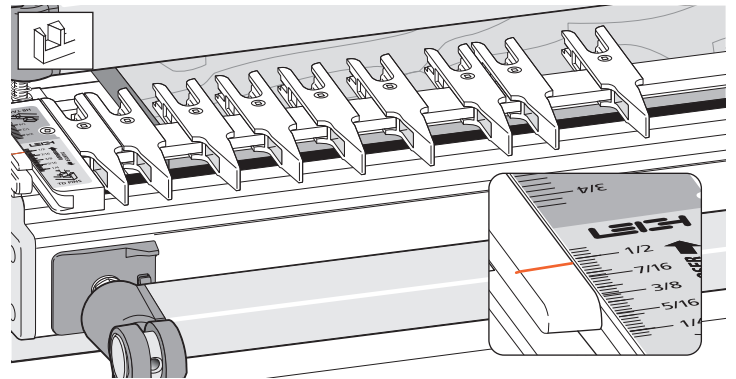

8-20 Rotate the finger assembly to TD PINS mode and set it on the 1/2" [12,7mm] mark ①. Do not change the guidefinger layout.

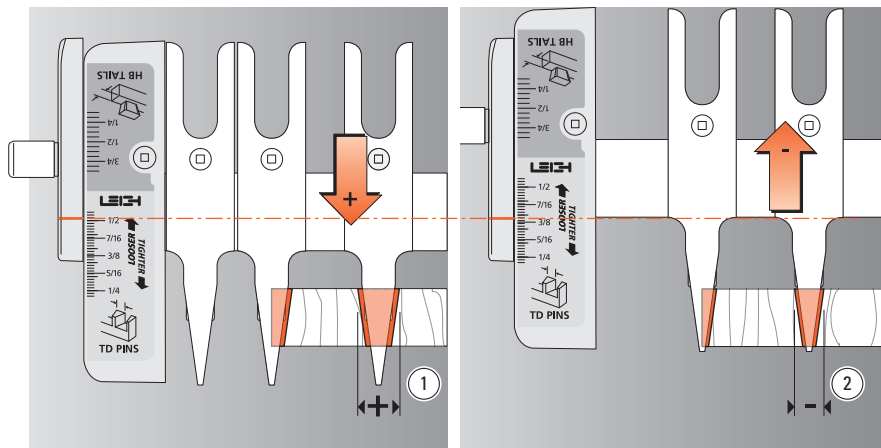

8-21 Finished Joint Tightness

The tightness of the finished joint is determined in TD PINS mode. The farther out toward the operator the finger assembly is set, the larger the pins will be ①. Moving the finger assembly in will make the pins smaller ②.

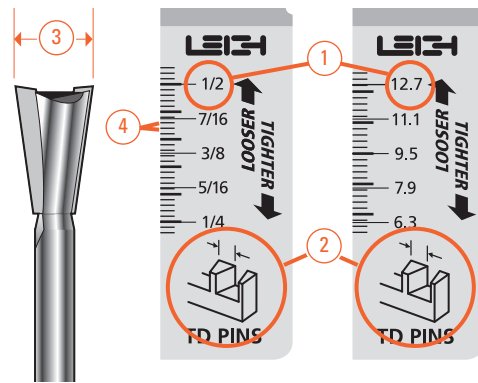

8-22 How the TD PIN Scales Work

The dimensions on the TD Pin scale ① indicate the major width of the pin to be routed ②. This matches the size of dovetail bit just used to rout the tails ③. The increment lines on the scale ④ are spaced so that moving the finger assembly by one increment changes the joint glue-line gap by just 0.005" [0,125mm]. Even better, a one quarter division movement changes the fit by 0.00125" [0,03mm], a tiny one and a quarter thousandth of an inch! Once you achieve the desired joint fit, simply record the setting using the illustrations at the end of this chapter.

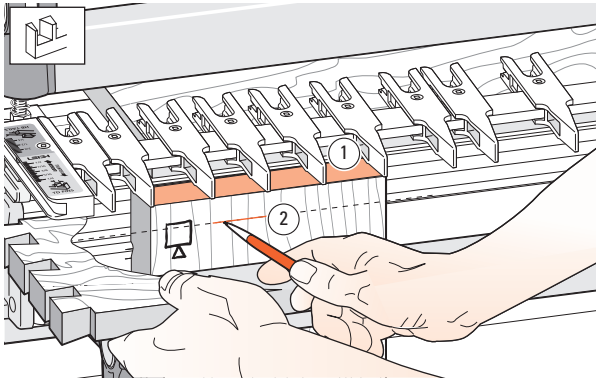

8-23 Clamp a test pin board against the left hand side stop, outside face  away from the jig, with the top end flush under the guides ①.

Place the side edge of one of the finished *tail boards* horizontally flush under the guidefingers and mark a thin pencil line part way across the pin board ②.

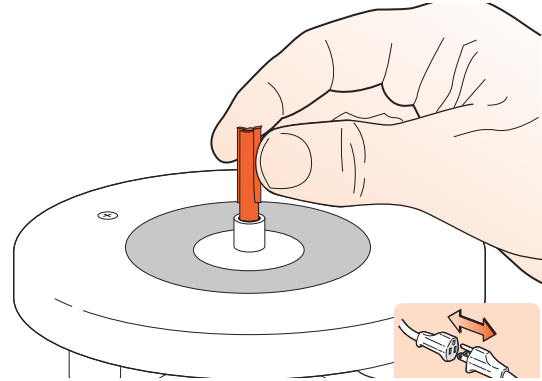

8-24 Unplug the router and remove the dovetail bit. Mount the included No. 140-8 straight bit to the router.

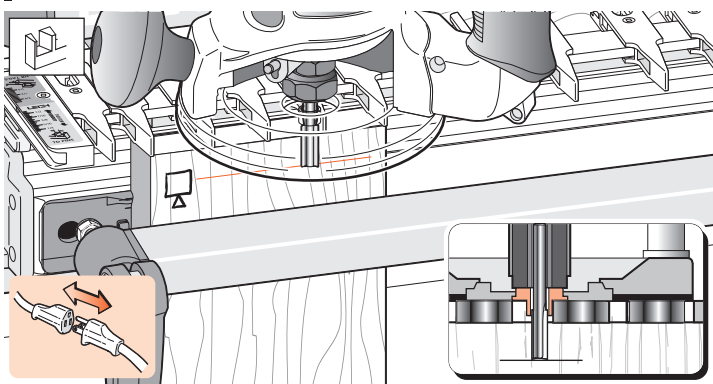

8-25 Place the router on the finger assembly and adjust the router until the bit tip is level with the center of the pencil line. Check to make sure the bit rotates freely.

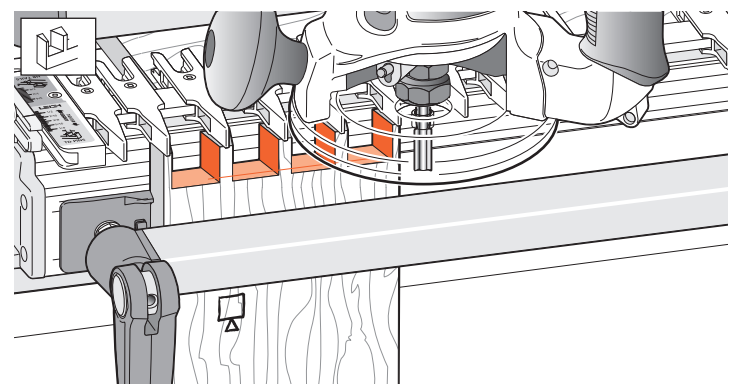

8-26 Rout out the waste between the pins. Check to make sure no parts have been missed. See Chapter 15 "Hints and Tips" on how to minimize tearout.

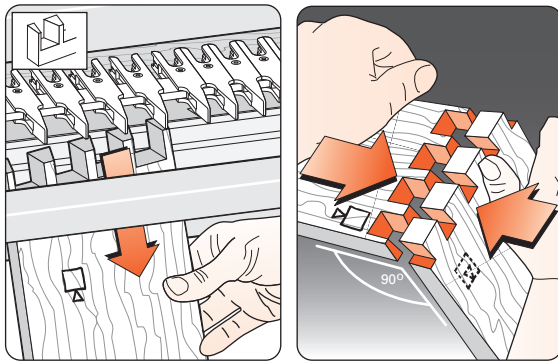

8-27 Remove the test pin board from the jig and test it for fit in one of the tail boards.

Make sure the outside faces outward on both pieces. A firm push fit is perfect, perhaps a tap with the heel of your hand. Having to use a mallet means the joint is too tight to take glue.

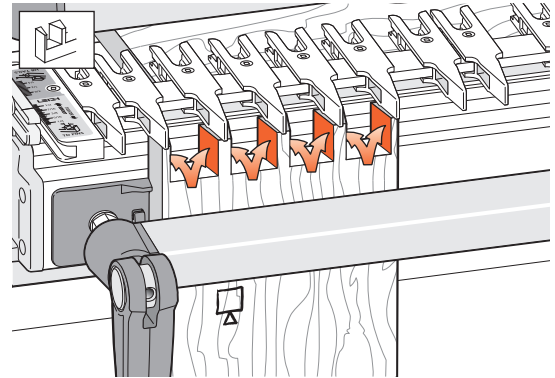

8-28 If it is too tight, move the finger assembly in (away from you) by one division on the scale. If it is only a little tight, adjust the scale by only half a division. Replace the same pin board back in the jig, carefully aligned against the same side stop. Rout off the sides of the pins and test it again for fit. Repeat as necessary to get a good fit.

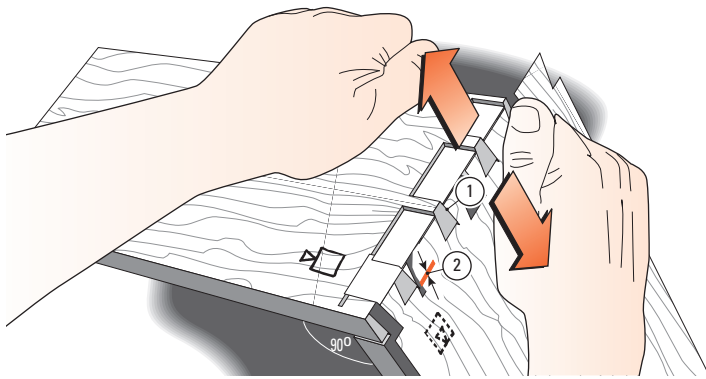

8-29 If the joint is loose, pull the pin board so that the angled sides of the pins and sockets jam tight together ①. The gap at the bottom of the pins ② is the amount you will have to move the finger assembly out (toward you). Reset the finger assembly and test again on the other end of this board.

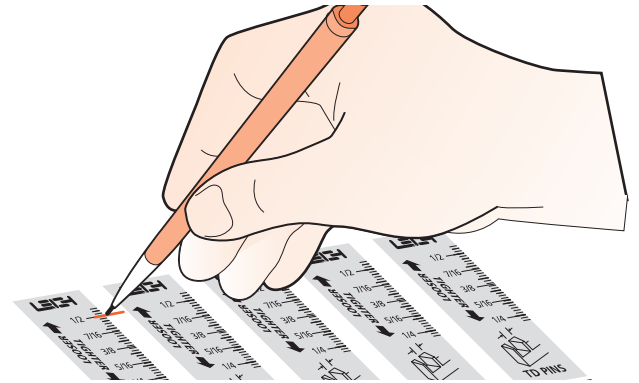

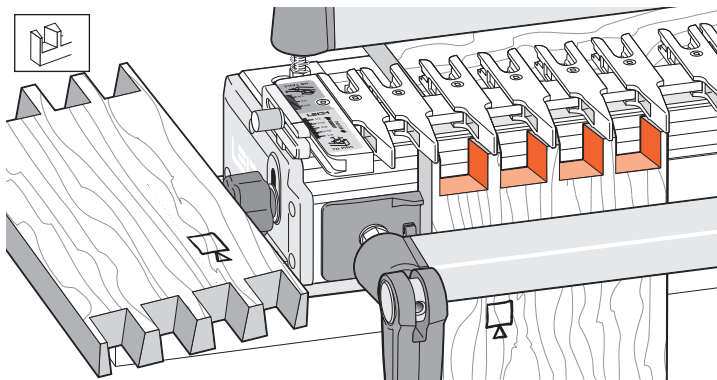

8-30 Once the correct fit is achieved, mark the final TD PINS scale setting on the pull-out or on one of the scale prints at the end of this chapter. Very slight variations to the scale setting may be necessary with different wood species or hardness. You can also note this on the Quick Reference pull-out card.

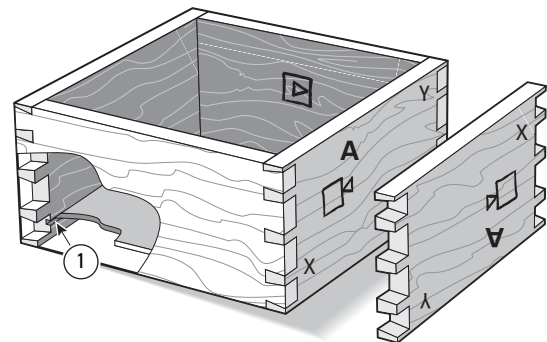

8-31 Rout all four ends of the pin boards, keeping the outside face  outwards. (With luck you may not have used the fifth board.)



8-32 Assemble the box, making sure the tail boards face the proper way, i.e. tail boards inside face in ; pin boards outside face out . Provided you haven't already routed out the drawer bottom grooves ①, it doesn't matter which edge of any of the boards are at the top or bottom, the box will still fit together i.e. pin board "A" can be up either way.

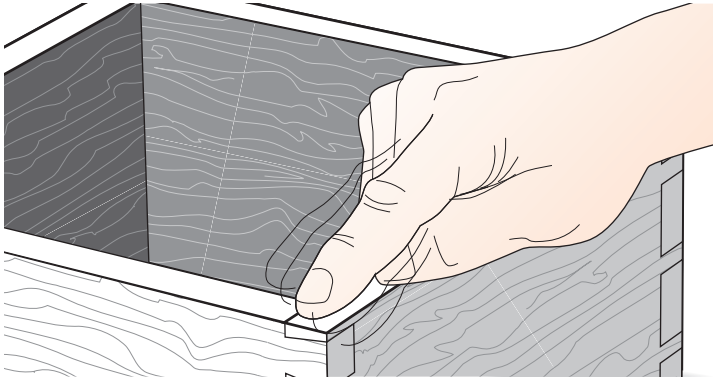

8-33 The box should be square and in plane. If it is not in plane (i.e., the side edges of each board are not in line), then either the ends of the boards are not square, the board widths are not exactly equal, or there is a concentricity problem (see 7-2 to 7-9).

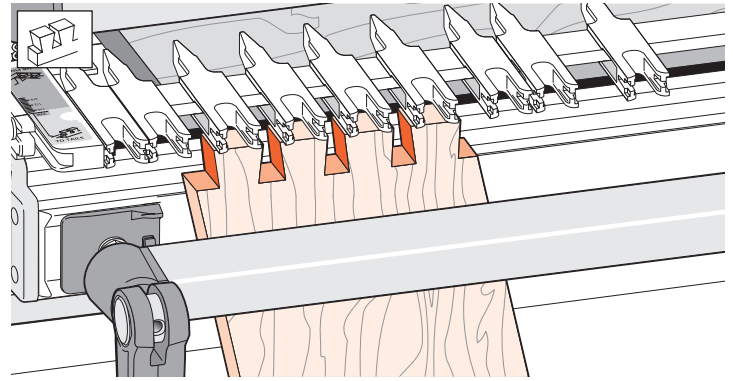

8-34 To form angled dovetails, refer to the Technical bulletin “How to Rout Angled Through Dovetails on your Leigh Jig”. You can download a printable file of the bulletin from our website: www.leighjigs.com ■

QUICK REFERENCE REMINDERS

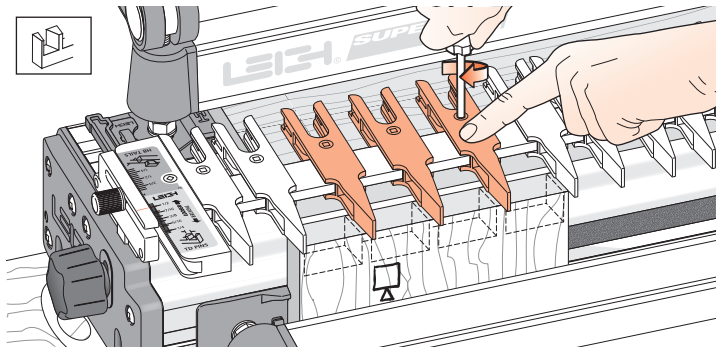

8-QR1 Through dovetails are laid out in TD PINS mode with the finger assembly slightly raised above the spacer board and the pin board. The outside face of the TD pins is away from the jig body.

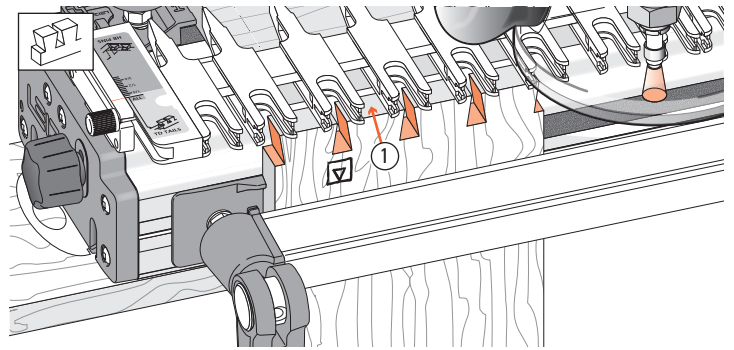

8-QR2 TD tail boards are clamped vertically in the jig. The inside face of the TD tails is away from the jig body. The finger assembly is in TD TAILS mode, set on the "ALL" setting. There is only one setting in this mode.

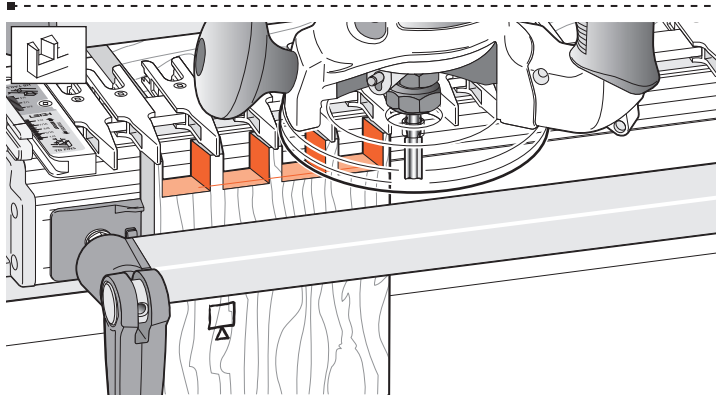

8-QR3 The finger assembly is in TD PINS mode, with the scale set to a recorded setting (see detailed fit instructions, 8-24 to 8-30). TD pins are cut with a straight bit; the only time a straight bit is used in dovetailing. This is the only one of the four main modes that puts the outside face of the board away from the jig body.

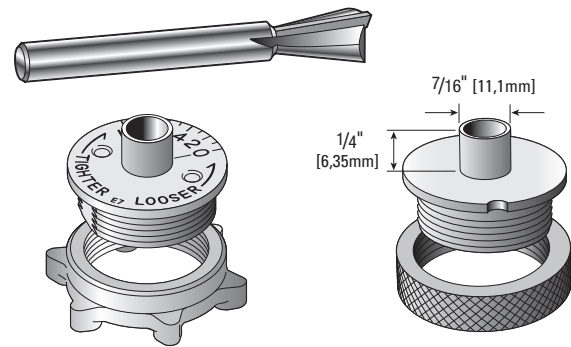

8-QR4 Through dovetail tails are always routed with an 8° dovetail bit to match the 8° guidefinger. All through dovetail routing on the Superjig is done with the Leigh e7-Bush, or any 7/16" [11,1mm] diameter bush (min. barrel length 1/4" [6,35mm]). See page 68 for more on routers and guide bushings.

Thickness of Tail Board	Thickness of Pin Board	Dovetail Bit	Straight Bit	Guidebush Diameter
up to 13/16" [21]	1/2" - 13/16" [12-20]	No.80-8	No.140-8	e7-Bush or 7/16" [11,1] diameter bush
up to 13/16" [21]	3/8" - 5/8" [10-16]	No.75-8		
up to 13/16" [21]	1/4" - 1/2" [6-13]	No.70-8		
up to 13/16" [21]	up to 3/8" [10]	No.60-8		
up to 13/16" [21]	up to 1/4" [6]	No.50-8		

Numbers in brackets are millimeters

8-QR5

Here is a quick reference selection chart for through dovetail bits. Please study the bit selection specifications in Appendix ii for full details of each through dovetail bit. Note: 13/16" [20mm] is the maximum through dovetail pin board thickness. Boards as thin as 1/8" may be routed and joined using through dovetail bits 50-8 and 60-8, along with straight bit 140-8

The Leigh e7-Bush or a straight barrel 7/16" OD guide bush are the only guide bushes that can be used with Super Jigs. ■

Variably Spaced Half-Blind Dovetail Procedures

IMPORTANT! The most commonly misunderstood aspect of routing half-blind dovetails is how the dovetail bit's depth of cut is used to adjust the joint fit, and how the angle of the bit affects that depth of cut. Review this chapter for a clear understanding of this concept.

Note: Use the e7-Bush set at "10", or any round ~7/16" [~11,1mm] bush (min. depth 1/4" see page 67), and any one of the five bits listed on the next page may be used for half-blind dovetails. See Appendix II "Half Blind Bit Selection" for a full description on how to select an appropriate bit.

1

Start in

Half-Blind Dovetail Tails (HB TAILS) mode

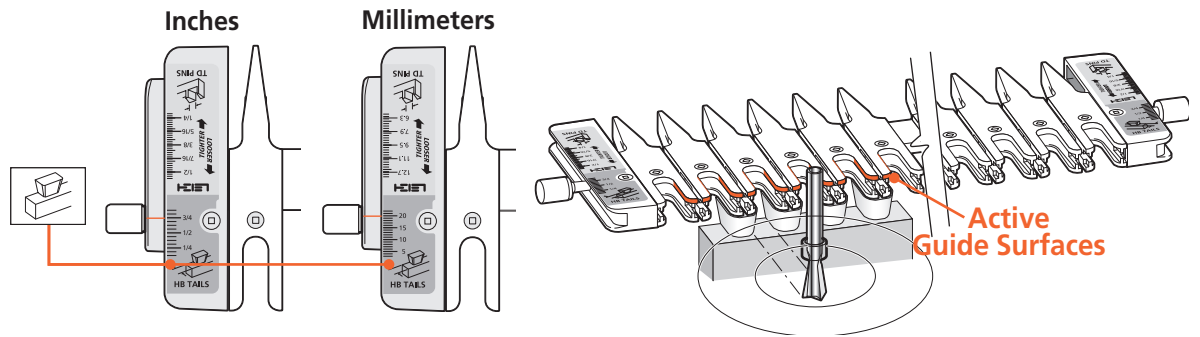

2

ROTATE the finger assembly toward you 180°

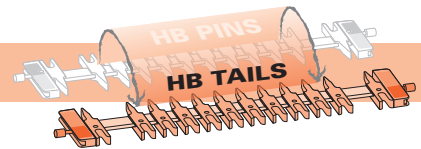

3

Now the Finger Assembly is in

Half-Blind Dovetail Pins (HB PINS) mode

MODE ICONS

Illustrations in this user guide include the correct *mode* icon for the current instruction. The icons are also used in the instruction text.

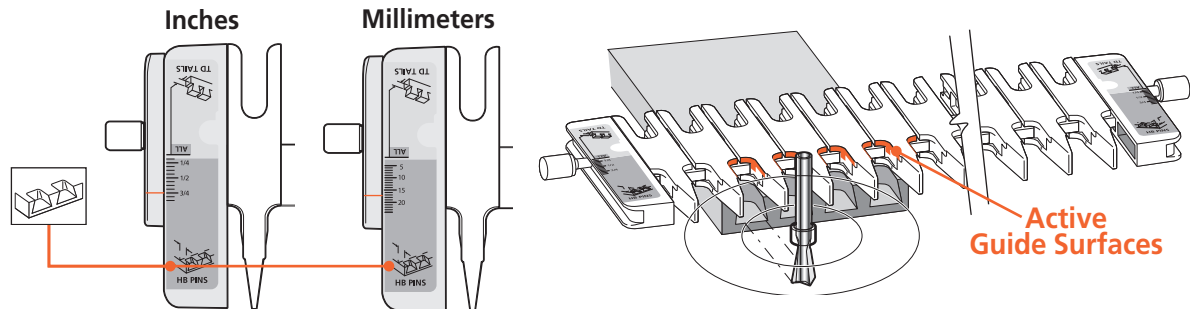

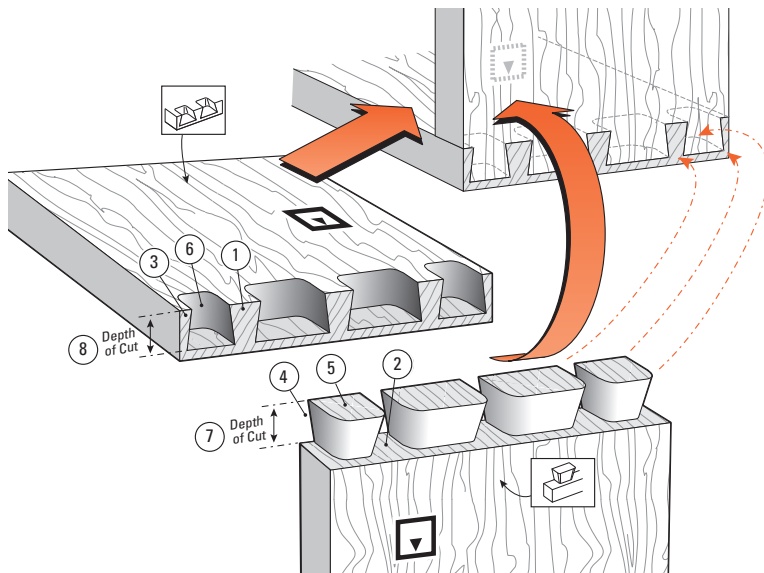

9-1 Half-Blind Dovetail Terminology:

- | | |
|--------------------|------------------------|
| ① Pins | ⑤ Tails |
| ② Pin sockets | ⑥ Tail sockets |
| ③ Half-pins | ⑦ Depth of Cut (tails) |
| ④ Half-pin sockets | ⑧ Depth of Cut (pins) |

The pins fit in the pin sockets. Joints almost always begin and end with a half-pin as shown.

9-2 Cutting Depth for Variably Spaced Half-Blind Dovetails

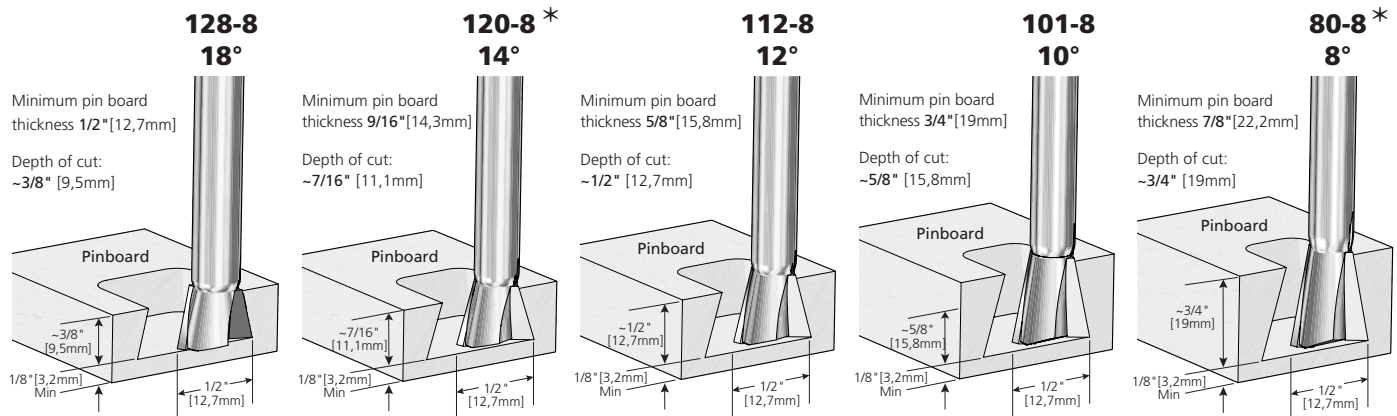

Note: Add at least $\frac{1}{8}$ " [3,2mm] to the depth of cut for board thickness. * Included with jig. ~ Symbol for "approximately"

⚠ Important! Read This About HB Depth of Cut

Bit selection is critical. You need to select a specific dovetail bit for your half-blind dovetail project, depending on the pinboard (drawer front) thickness you are using.

- Choose one of the five $\frac{1}{2}$ " [12,7mm] diameter dovetail bits shown above. Check bit selection in Appendix II.
- Depth of cut must be as specified for each of the five bits illustrated above.

Note: Leigh bits 101-8, 112-8 and 128-8 are optional.

- Raising the bit above its specified cutting depth will result in loose joints and may damage the jig, bit and/or guidebush. A lower setting will result in tighter joints that may not fit together.
- Small Depth of Cut adjustments will change joint fit tightness. See *why in Steps 9-3 to 9-5.*

- Half-blind PINS and TAILS are routed with the same dovetail bit and must be at the same Depth of Cut.
- All half-blind dovetail bits work with the Leigh e7-Bush supplied with your Leigh jig or standard $\frac{7}{16}$ " [11,1mm] outside diameter guidebush.
- A dovetail bit will produce only on specific cutting depth. Only $\frac{1}{2}$ " [12,7mm] cutting diameter bits can be used for half-blind dovetails.

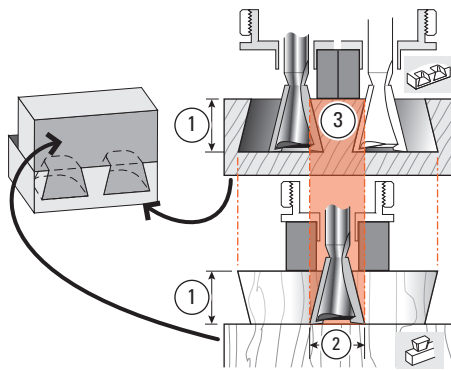

9-3 Joint Fit and Depth of Cut

Here's why the depth of cut ① changes the fit in half-blind dovetails. Increasing or decreasing the depth of cut does not affect the pin socket width ②, but does affect the width of the pin ③ that goes into the socket ②.

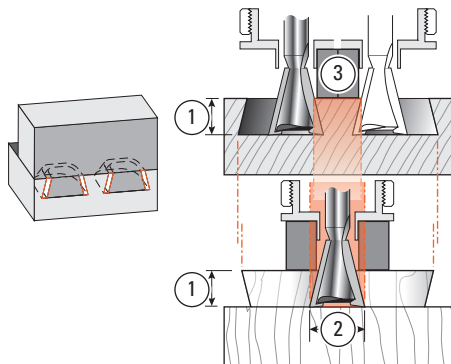

9-4 Note that decreasing the bit depth ① makes the pin ③ narrower while the pin socket ② stays the same width, producing a loose fit.

Decreasing the bit depth (i.e. raise the bit into the router) produces a looser fit.

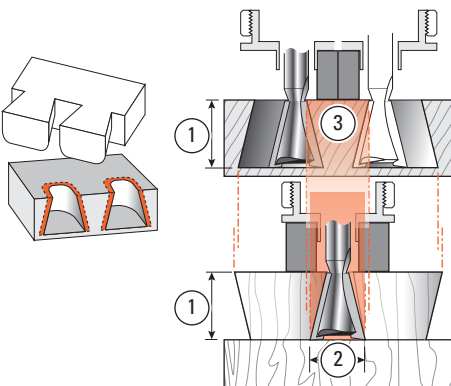

9-5 Increasing the bit depth ① makes the pin ③ larger while the pin socket ② stays the same width, producing too tight a fit. Increasing the bit depth (i.e. lower the bit) produces a tighter fit.

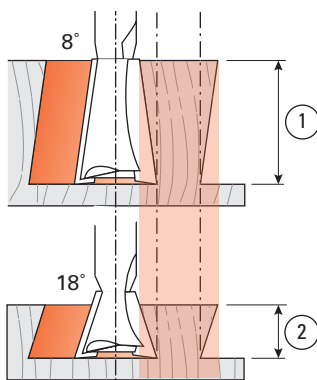

9-6 Bit Angle and Depth of Cut Half-blind pins and tails are routed with the same dovetail bit, the **same** guidebush, and the **same** depth of cut. A different depth of cut requires a different angled bit. Leigh offers five different angled dovetail bits for a range of cut depths. A lesser angle, say 8°, for a deeper cut ①; a greater angle, say 18°, for a shallower cut ②.

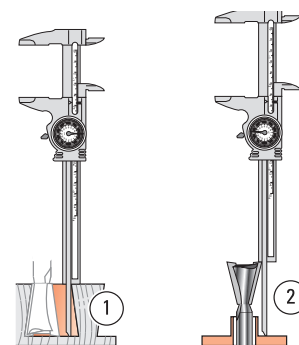

9-7 Cumulative plus/minus tolerances in routers, bits and guidebushes, make it impossible to state exact bit depth for first-time precision fit. All dovetail jigs require trial and error tests to attain fine fitting joints. The good news; we give a starting depth for each bit. Test and measure the successful 'Best fit' depth of cut ① or bit projection ②. Record for future first-time fits.

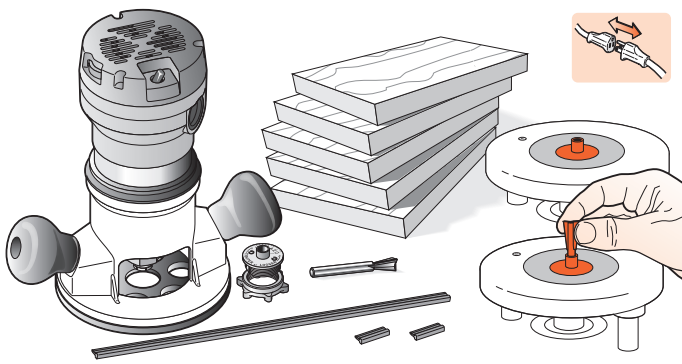

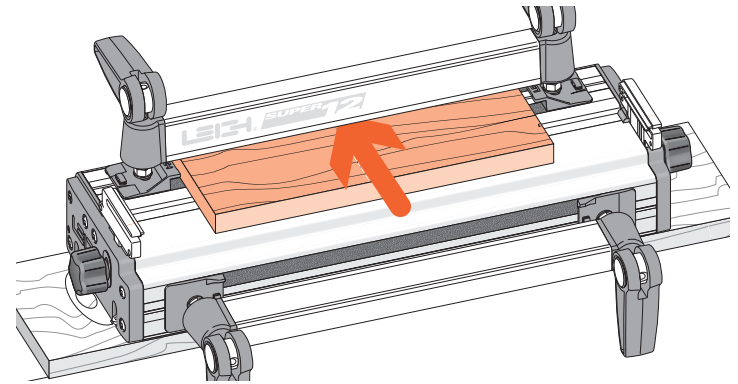

9-8 Routing a Test Joint Use the e7-Bush or a $\frac{7}{16}$ " [11,1mm] diameter bush (min. depth $\frac{1}{4}$ " *see page 67*) and No.120-8 $\frac{1}{2}$ " [12,7mm] 14° dovetail bit. (80-series bits cut too deep for $\frac{3}{4}$ " [20mm] boards, see HB bits, Appendix II). Select several pieces of $\frac{3}{4}$ " x $5\frac{1}{2}$ " [20x140mm] x about 8" [200mm], and the plastic bridge. *Note: Half-blind pin boards must be minimum $\frac{1}{2}$ " [13mm] thick to clamp. Thinner boards; see 9-21.*

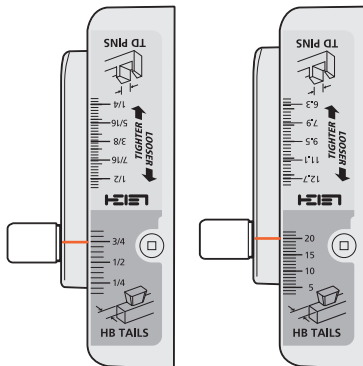

9-9 Clamp the spacer board in the rear clamp.



9-10 Mount the finger assembly on the support brackets in the  HB TAILS mode, flat on the spacer board, scales set on the thickness of the tail board ($\frac{3}{4}$ " [20mm] in this instance). The  HB TAILS scale is always set at the tail board thickness. Max tailboard thickness is 1" however max scale setting is $\frac{3}{4}$ ".

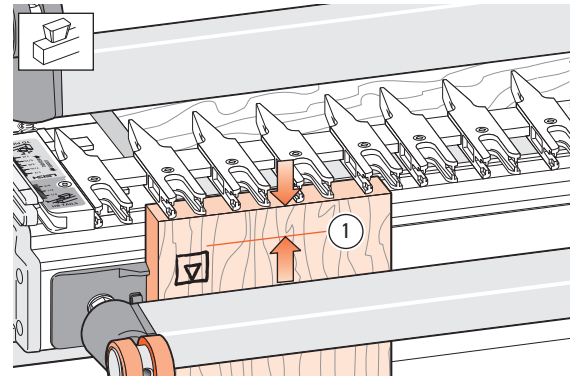

9-11 Measure and mark a line on the inside face of the tail board ① to the bit's depth of cut as in 9-2. Clamp this test tail board in the left front clamp, against the side stop with the top edge flush under the guidefingers, and the inside face  of the drawer side away from the jig.

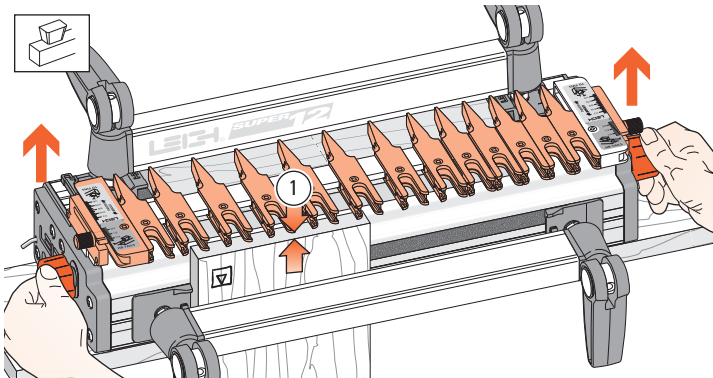

9-12 Unlock and raise the finger assembly support brackets slightly so that the finger assembly is about $\frac{1}{16}$ " [2mm] ① above the boards. This will allow easy movement of the guidefingers.

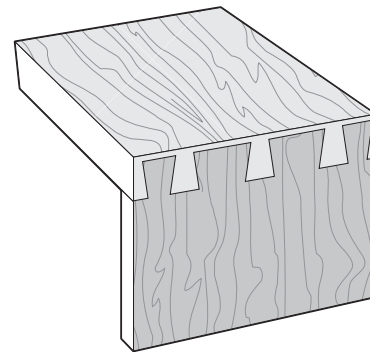

9-13 The following joint design is suggested for this trial. It has a typical and traditional even layout of pins, with half-pins at each edge. The Leigh jig, however, allows for an infinite variety of joint designs, and boards of different thicknesses can be joined to each other as shown in this illustration. Before attempting joints of asymmetrical design, see chapter 12.

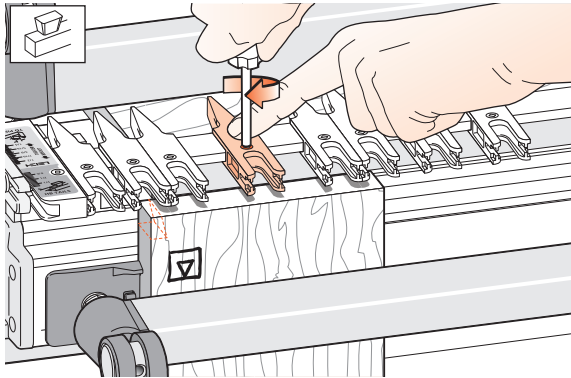

9-14 Ignoring the extreme outer guidefinger next to the scale (which just supports the router), loosen enough of the adjacent guides to give the required pin socket layout. The half-pin guidefinger position illustrated will give a half-pin socket profile like that shown (dotted lines).

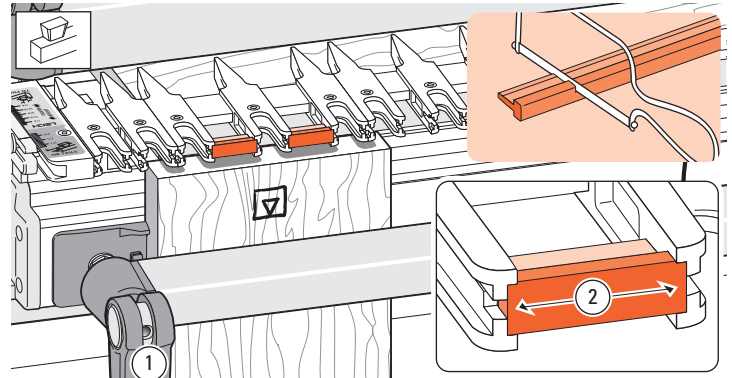

9-15 If the gaps between the guidefinger tails are wider than about 1/8" [3mm], mark off and cut some pieces of bridge extrusion ① to fit into the slots in the ends of the guidefinger tails. Cut the pieces a "bare" 1/8" [3mm] more than the distance between the fingers ②. They are a firm friction fit.
After completing a project, save the bridge pieces for future use.

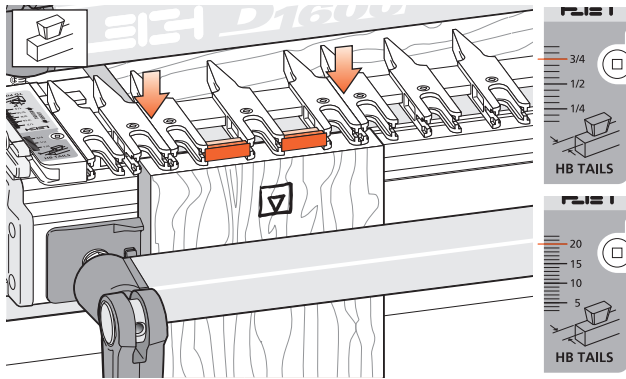

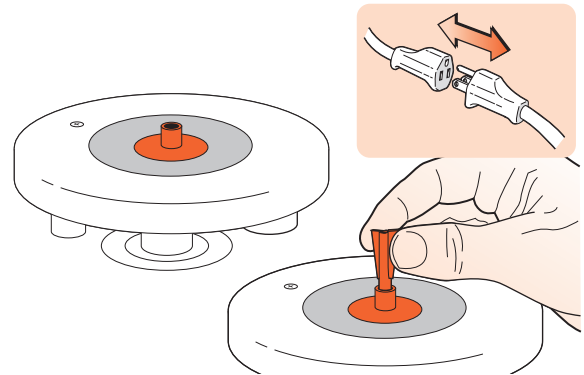

9-16 Remember to tighten any loose guidefingers. Lower the finger assembly back onto the spacer board and workpiece. It must touch the workpiece or the depth of cut will vary and the joint won't fit. The scale should be set on the tailboard thickness, in this case 3/4" [20mm].

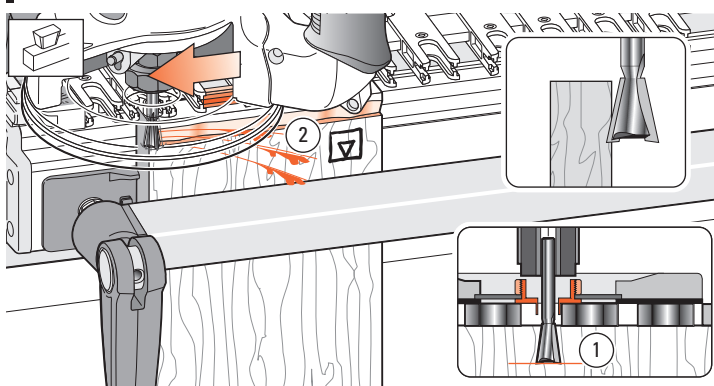

9-17 Attach the provided e7-Bush or a 7/16" [11,1 mm] diameter bush securely to the router. No guidebush adjustment is required with half-blind dovetails. Fit the selected dovetail bit to the router.

REMEMBER SAFETY!



9-18  Adjust the bit height until the bit tip is level with the marked line ①. For the first light cut move the router from right to left. Make sure you control it firmly, because it is driven in this direction by the bit. Only the tip of the bit should be cutting on the first cut ②. This *back* or *climb* routing leaves a very clean shoulder in side grain.

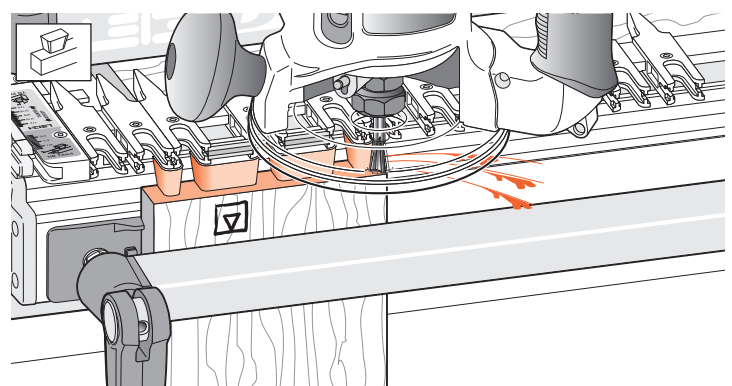

9-19 Now rout in and out from left to right following the guides and bridge pieces to rout out the pin sockets, leaving the tails. See *Hints and Tips 15-11*. Remove the tail board.

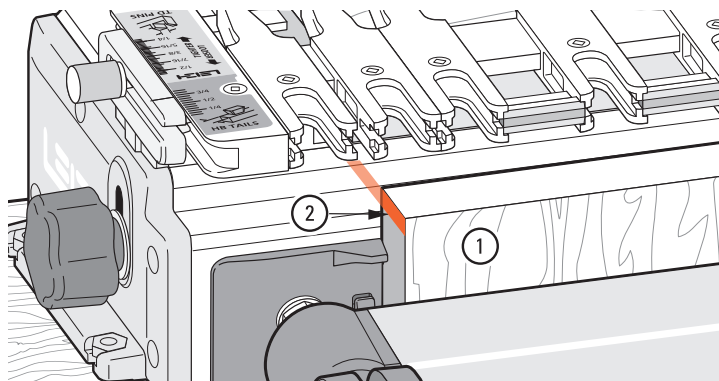

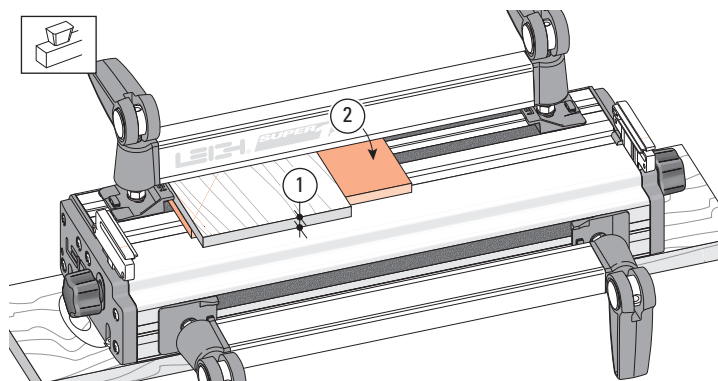

9-20 Clamp a scrap board ① in the front of the jig so that the top edge of the scrap board projects above the top face of the jig by about $\frac{1}{8}$ " [3mm] ②. This will keep the scrap piece below the path of the bit when routing the pin board. Remove the spacer board from the rear clamp.



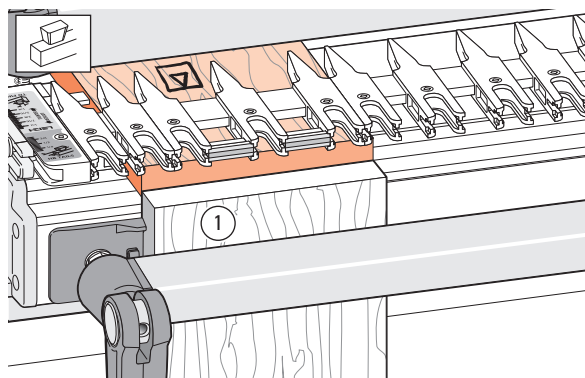

9-21 If you're mounting Thin Pin Boards:

Minimum recommended pin board thickness is $\frac{1}{2}$ " [13mm]. Remember, No.128-8 bits rout at $\frac{3}{8}$ " [9,5mm] deep. If you rout a pin board less than minimum thickness ①, you need to pack the board up from the jig body. We suggest a piece of $\frac{1}{4}$ " to $\frac{3}{8}$ " [6 to 9mm] plywood for this purpose ②.

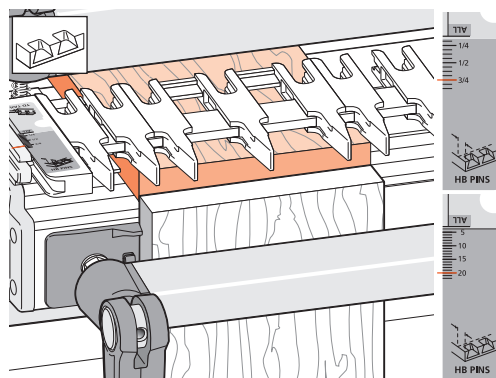

9-22 Flush Drawers Place a test pin board in the left rear clamp against the side stop, its front end edge flush to the vertical board, the inside face  of the drawer front away from the jig body. The pin board is now positioned with the edge to be routed flush with the jig's front face, correctly registered for the scale readings. For rabbeted drawer fronts, see Chapter 11.



9-23 Rotate the finger assembly to  HB PINS mode. Set the HB pins scale *equal to tail board thickness* (i.e., same setting as tails: this example, $\frac{3}{4}$ " [20mm]). HB pins and HB tail scales are always set to tail board thickness. Make sure the finger assembly is flush and level on the pin board. The guidefingers must touch the pin board or depth of cut will vary, causing poor joint fit.

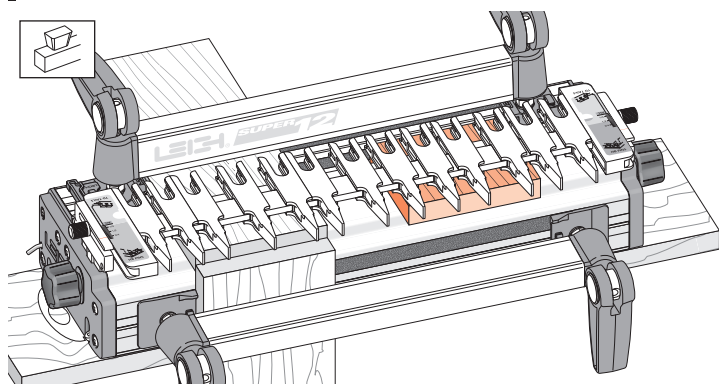

9-24 If you have difficulty leveling the finger assembly on a narrow workpiece, place a board the same thickness as the pin board under the other end of the finger assembly, **but not in the rear clamp**.

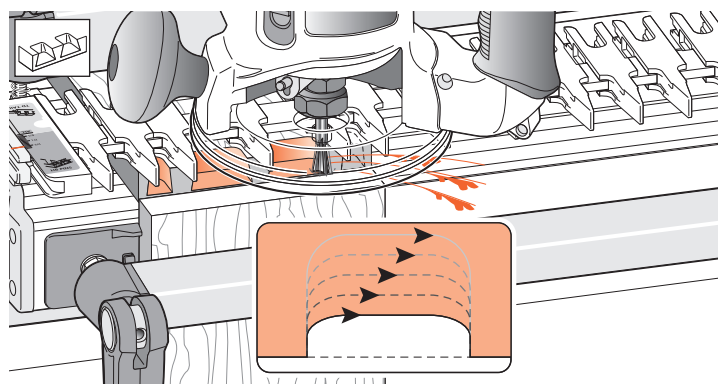

9-25  Rout out the waste between the pins. Rout each space from **left to right**. Do not back-rout on end grain. If the bit enters on the right side of the opening there will be a very strong pull to the left, so... rout each opening in at least three or four passes, left to right.

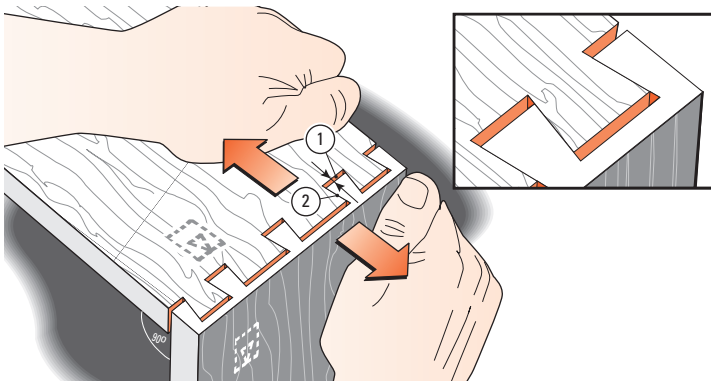

9-26 Remove the pin board and test for fit. If the joint is loose, as shown here, you need to **increase the bit cutting depth** by the same amount as the gap at the bottom of the pins ① (when the pins are pulled against the socket sides ②). If the joint is too tight, **decrease the bit cutting depth** slightly. Test again. Boards cannot be routed twice with a dovetail bit. Use two fresh board ends for each test.

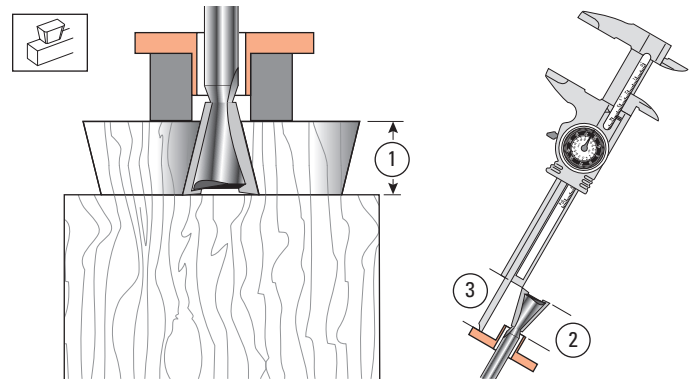

9-27 Keep the test tail board that fits well, and mark it with the number of the bit you used to rout it. For quick set-up next time, clamp this tail board in the jig as a **depth-of-cut gauge** ① to show how far to lower the bit. Better yet, measure the bit projection from the end of the guidebush ② or guidebush flange ③ and record this for fast set-ups in future.

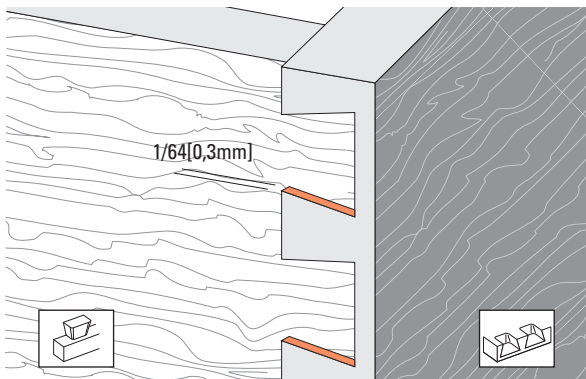

9-28 When you have the proper tightness of fit, check the flushness. The tails should be under flush to the pins by **no more than 1/64" [0,3mm] to allow for cleanup** (exaggerated here). Any concentricity errors in the collet and guidebush on different routers will affect this tolerance.

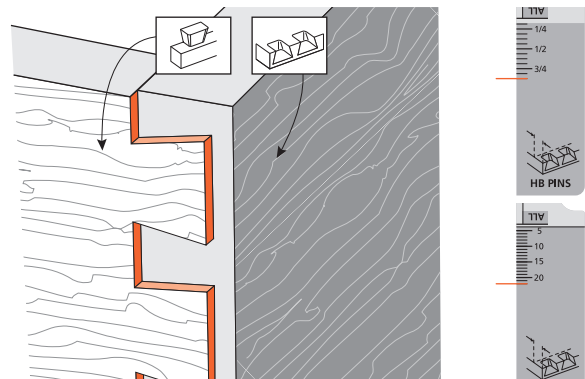

9-29 If the tails stand out from the pins, set the HB PINS scale **away from the operator** by the amount required.

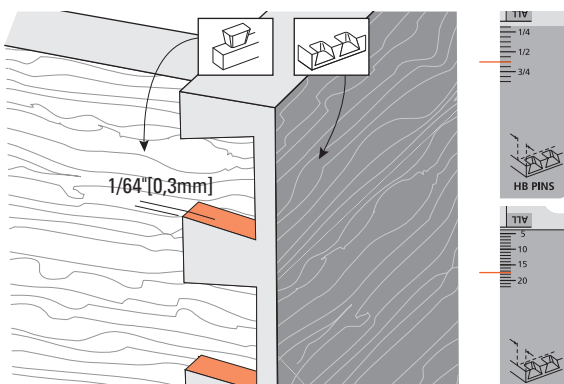

9-30 If the tails fit in too far past the pins ends, set the HB PINS scale **toward the operator** by the amount required. These adjustments for “flushness” are made only in the HB PINS mode.

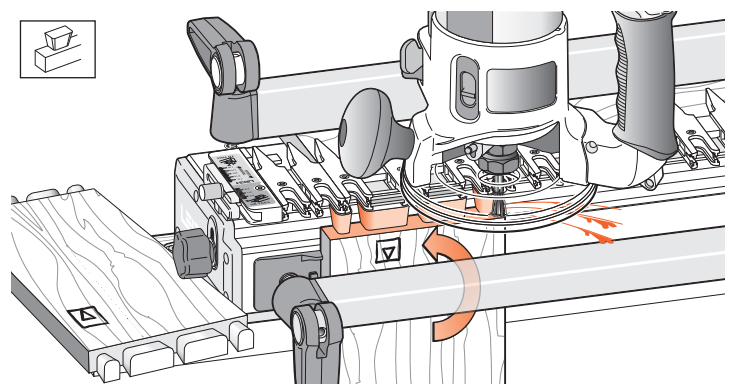

9-31 To make a box, rout all four ends of the tail boards, keeping the inside face of the tail boards away from the jig.

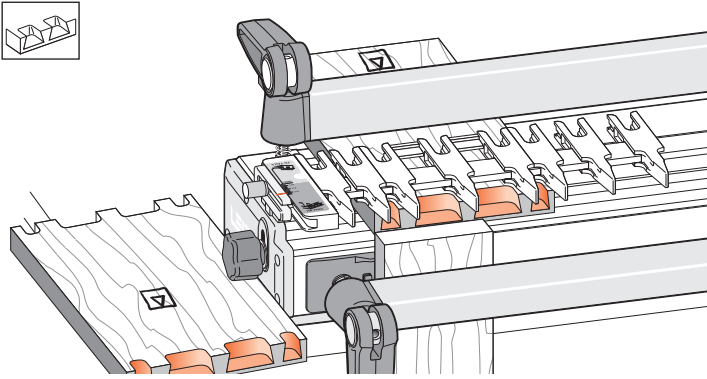

9-32 Rout all four ends of the pin boards keeping the inside face  of the boards away from the jig.

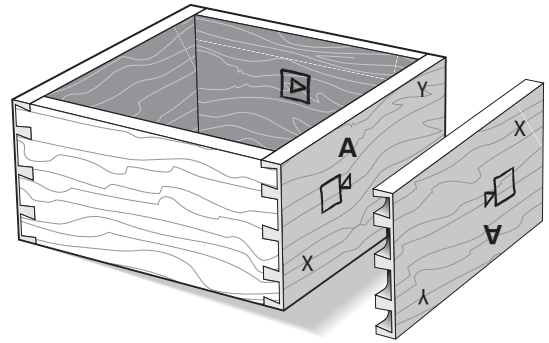

Note: When making drawers you may prefer to use through dovetails on the rear corners.



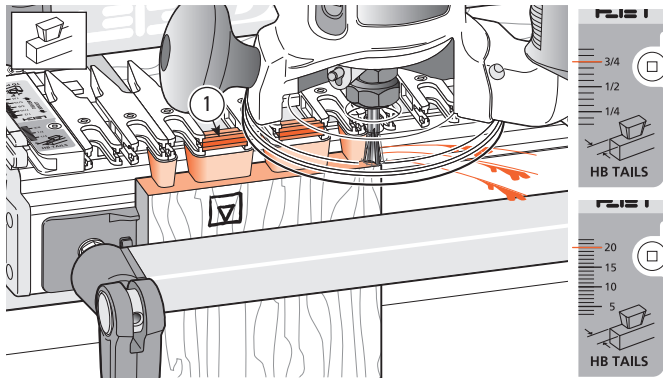

9-33 Assemble the box. As with through dovetails, it doesn't matter which edge of any of the boards are at the top or bottom, the box will still fit together e.g. pin board "A" can be up either way.



QUICK REFERENCE REMINDERS

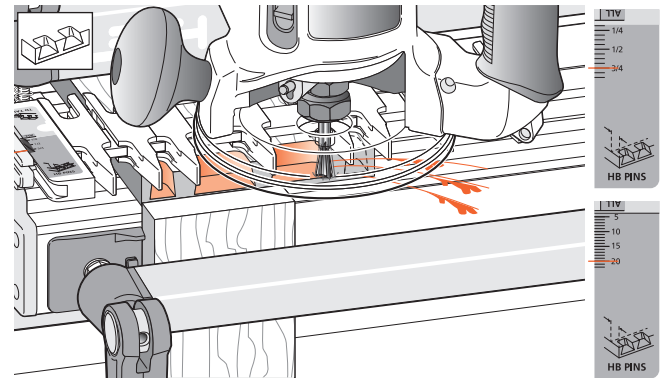

9-QR1 Half-blind (HB) tails: Drawer sides (tailboards) are clamped vertically in the jig. The inside face  of the drawer side goes away from the jig body. The finger assembly is in the  HB TAILS mode, set to the thickness of the drawer side. Use bridge pieces where required .

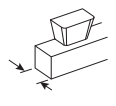
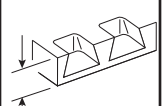
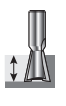

9-QR2 Half-blind (HB) pins: Drawer fronts (pinboards) are cut with the board clamped horizontally in the jig. The inside face  of the drawer front faces away from the jig body. The finger assembly is in the  HB PINS mode, and again set on the thickness of the drawer side (but adjusted for a flush fit, see 9-28 to 9-31).

				
Thickness of Tail Board	Thickness of Pin Board	Depth of Cut	Dovetail Bit	Guidebush Diameter
up to 1" [26]	7/8" - 1" [22]	~ 3/4" [19]	No.80-8	e7-Bush or
up to 1" [26]	3/4" - up [20]	~ 5/8" [16]	No.101-8	
up to 1" [26]	5/8" - up [16]	~ 1/2" [13]	No.112-8	7/16" [11,1] guidebush
up to 1" [26]	9/16" - up [14]	~ 7/16" [11]	No.120-8	
up to 1" [26]	1/2" - up [12]	~ 3/8" [9]	No.128-8	

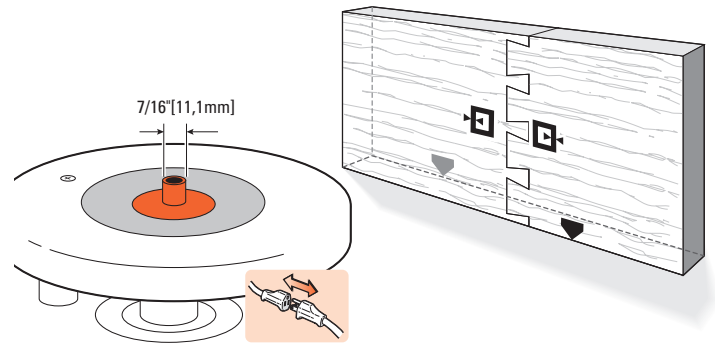

9-QR3 On the Leigh Superjig, all half-blind dovetails are routed using the e7-Bush or a 7/16" [11,1mm] diameter (min. depth 1/4" see page 67) bush. Instructions for end-on-end dovetails are at www.leighjigs.com/support.php. Scroll down Bulletins to "Superjig/D1600 End on End Dovetails". ■

Single Pass Half-Blind Dovetails

Why rout "single pass" dovetails on a variably spaced Leigh jig? Well, you just may need to reproduce or restore a late 19th or early 20th century drawer which has similar, machine made joints. Or, if you are making a lot of drawer boxes and are not so concerned with the traditional "hand-cut look", then routing both drawer fronts and sides together does go a little faster.

Only one mode is required:

Half-Blind Dovetail Tails (HB TAILS) mode

MODE ICONS

Illustrations in this user guide include the correct *mode* icon for the current instruction. The icons are also used in the instruction text.

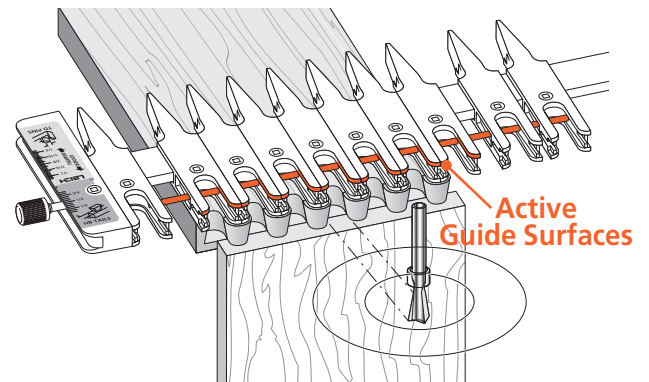
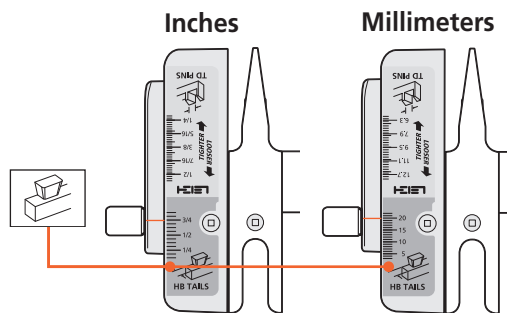

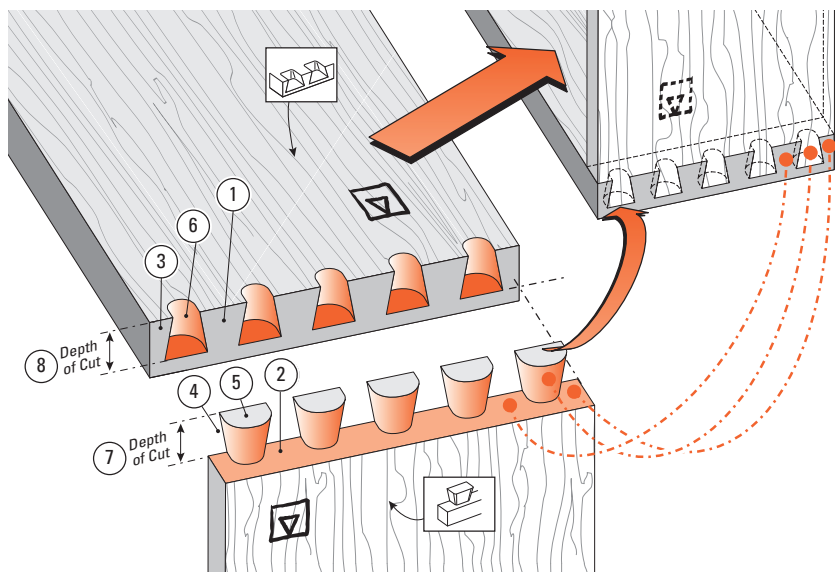

10-1 Single Pass Half-Blind Dovetail Terminology:

- ① Pins
- ② Pin sockets
- ③ Half-pins
- ④ Half-pin sockets
- ⑤ Tails
- ⑥ Tail sockets
- ⑦ Depth of Cut (tails)
- ⑧ Depth of Cut (pins)

The pins fit in the pin sockets. Joints almost always begin and end with a half-pin as shown.

10-2 Cutting Depth for Single Pass Half-Blind Dovetails

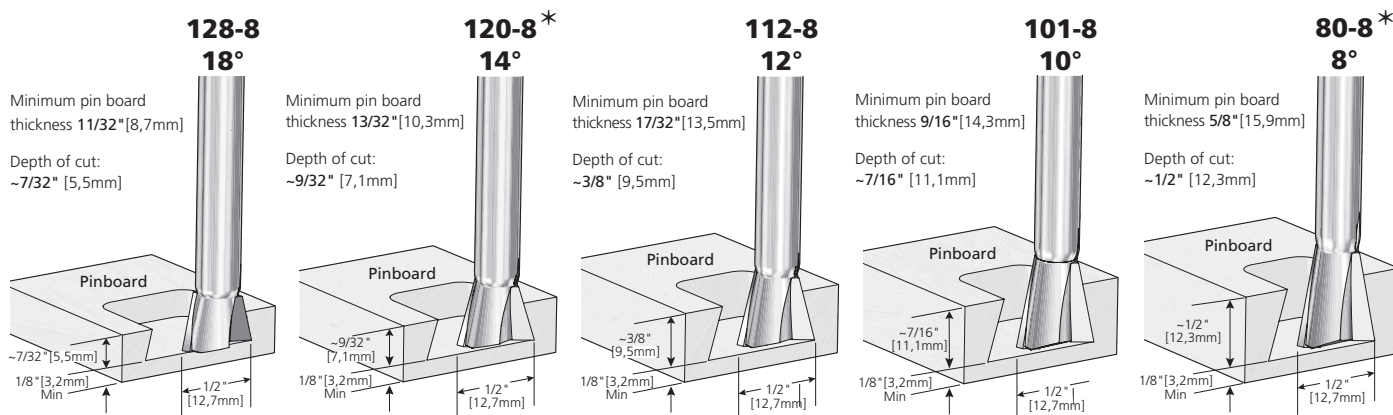

Note: Add at least 1/8" [3,2mm] to the depth of cut for board thickness. * Included with jig. ~ Symbol for "Approximately"

! IMPORTANT! Bit depths of cut for "single pass" dovetails are not the same as for variably spaced joints.

- Depth of cut must be as specified for each of the five bits shown above. *Exception: See fig.11-26. Note: Leigh bits 101-8, 112-8 and 128-8 are optional.*
- Raising the bit above its specified cutting depth will result in loose joints and may damage the jig, bit and/or guidebush. A lower setting will result in tighter joints that may not fit together.
- Small Depth of Cut adjustments will allow for joint fit tightness. **See why in Steps 9-3 to 9-5.**
- Choose one of the five, 1/2" [12,7 mm] diameter dovetail bits shown above.
- Fit the provided Leigh e7-Bush to the router as shown below and set at No.10, or use a standard 7/16" [11,1 mm] guidebush (min. barrel depth 1/4" see page 67).

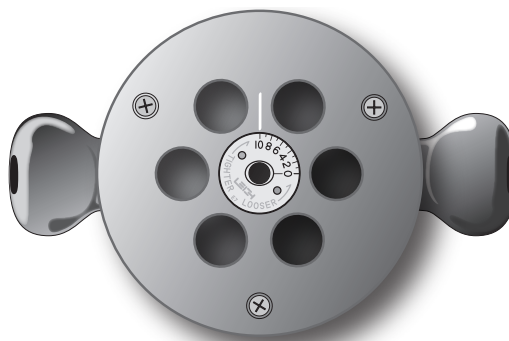

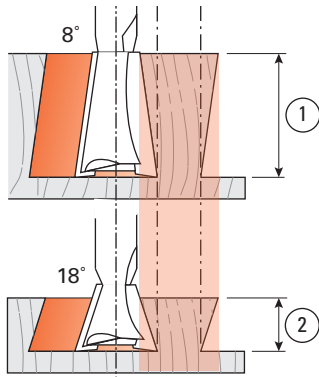

10-3 Bit Angle and Depth of Cut. Half-blind pins and tails are routed with the **same** dovetail bit, the **same** guidebush, and the **same** depth of cut. A different depth of cut requires a different angled bit. Leigh offers five different angled dovetail bits for a range of cut depths. A lesser angle, say 8°, for a deeper cut ①; a greater angle, say 18°, for a shallower cut ②.

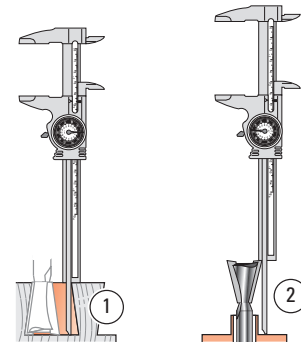

10-4 Cumulative plus/minus tolerances in routers, bits and guidebushes, make it impossible to state exact bit depth for first-time precision fit. All dovetail jigs require trial and error tests to attain a fine fitting joint. The good news; we give a starting depth for each bit. Test and measure the successful 'Best fit' depth of cut ① or bit projection ② and record for future first-time fits.

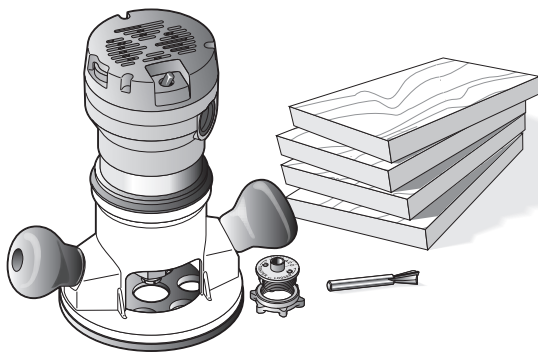

10-5 Routing a Test Joint You need a router, the e7-Bush set at No.10, the 80-8 1/2" [12,7mm] 8° dovetail bit, two 3/4" [19mm] thick pin boards and two 1/2" thick tail boards. The No.80-8 bit routs at a shallower ~1/2" [13mm] depth on single pass dovetails than on regular variably spaced joints. For this test, start with the No.80-8 bit projecting 1" [26mm] from the router base.

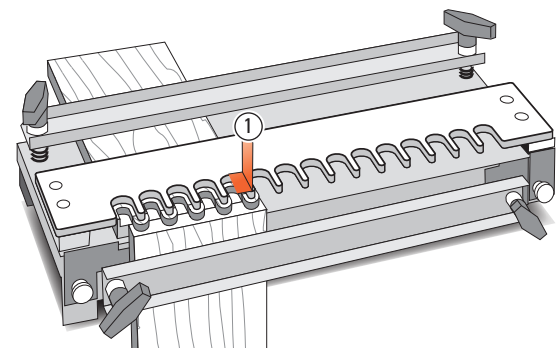

10-6 This is a typical fixed template comb type jig. The comb depth ① is usually dimensioned to suit the most popular drawer side thickness of 1/2" [12,7mm].

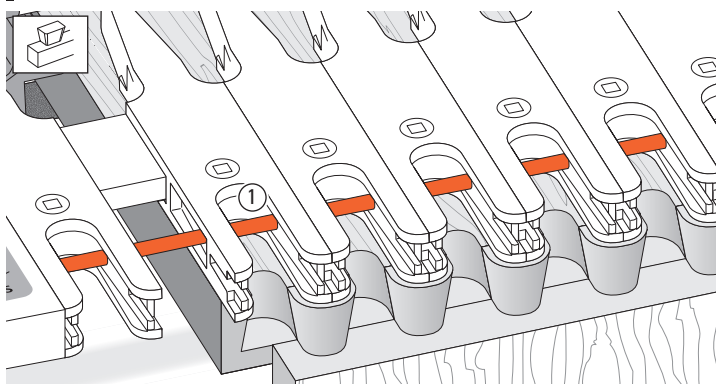

10-7 Superjig features two novel innovations. A Stop Rod inserted through the fingers ① limits router travel to allow the deep tail socket guides to function as a simple shallow fixed comb.

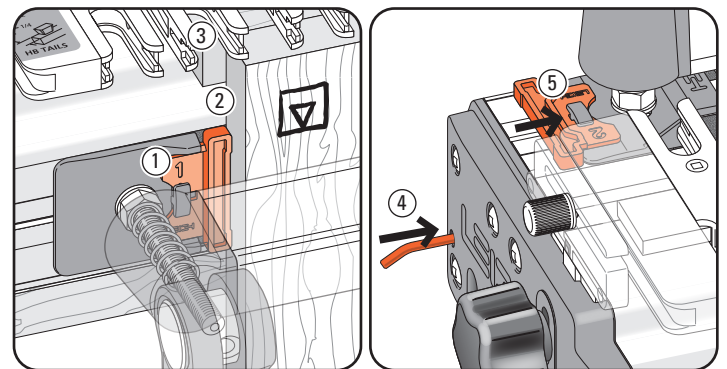

10-8 The Spacer in the #1 position, slipped into the left-hand front side stop ① correctly offsets drawer sides ② from drawer fronts ③. The Spacer stays in place for the complete procedure. The Stop Rod stores here ④ and the Spacer here ⑤.

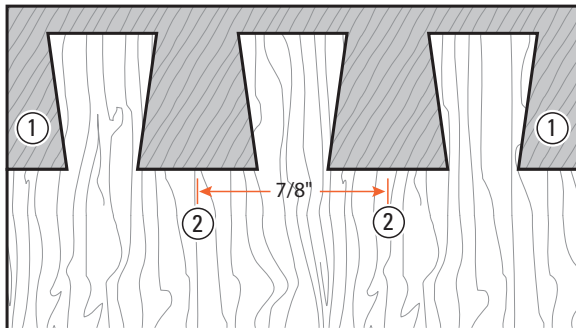

Board Width Chart		
Add up to 1/4" [6mm] or subtract up to 1/8" [3mm]		
7/8 [22]	6 1/8 [156]	11 3/8 [289] (SJ-18)
1 3/4 [44]	7 [178]	12 1/4 [311]
2 5/8 [67]	7 7/8 [200]	13 1/8 [333]
3 1/2 [89]	8 3/4 [222] (SJ-12)	14 [356] (SJ-24)
4 3/8 [111]	9 5/8 [244]	
5 1/4 [133]	10 1/2 [267]	

10-9 Board Widths: To achieve equally sized half pins ① at each side of a fixed space joint, use chart width plus up to 1/4" [6mm], or chart width minus up to 1/8" [3mm]. This chart covers boards up to maximum width for each jig. Pin centers ② will always be 7/8" for Single Pass Half-blind dovetail joints.

Example: the 7" [178mm] can be up to 7 1/4" [184mm] or as small as 6 7/8" [175mm].

Note: This test joint is for 3/4" thick drawer front, 1/2" thick drawer side and #80-8 dovetail bit. Scale settings and depth of cut will vary depending on bit selection and tail board thickness.

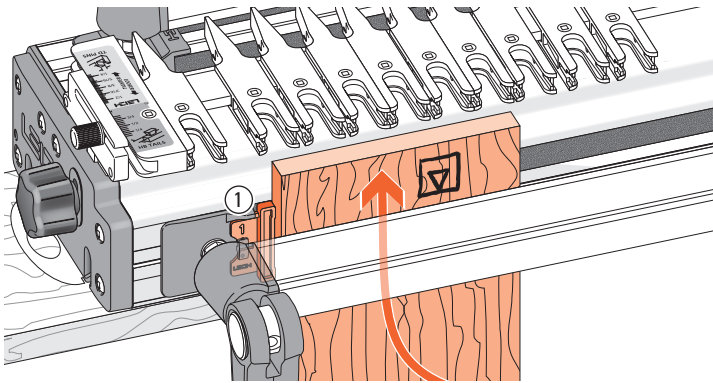

10-10 Slip the Spacer onto the left hand front side stop ①, *note: No 1 to the top.* With the finger assembly raised in the HB Tails mode, clamp a drawer side in the front left side, against the Spacer and the top end edge slightly above the jig body top.

Note: Drawer side thickness can be from 7/16" to 9/16" [6 to 14mm]. See 10-26 for Drawer Sides (Tail Boards) 5/8" and thicker.

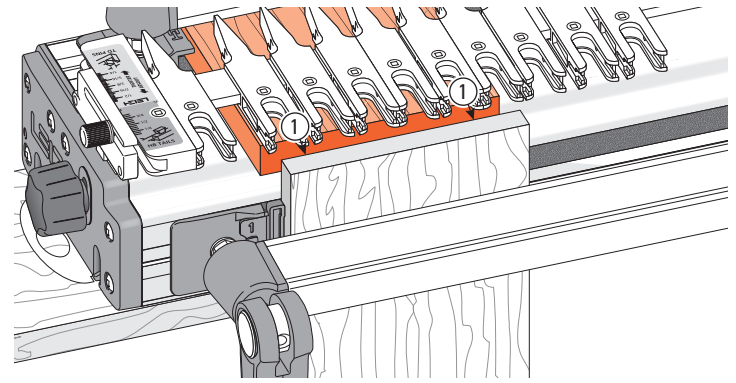

10-11 Place the drawer front (from 1/2" to 1" thickness [16 to 25mm]) in the rear clamp. Clamp with the side edge against the left rear side stop, front end edge touching flush across the rear of the front board ①. Lower the finger assembly to the drawer front.

! Board edges must be square.

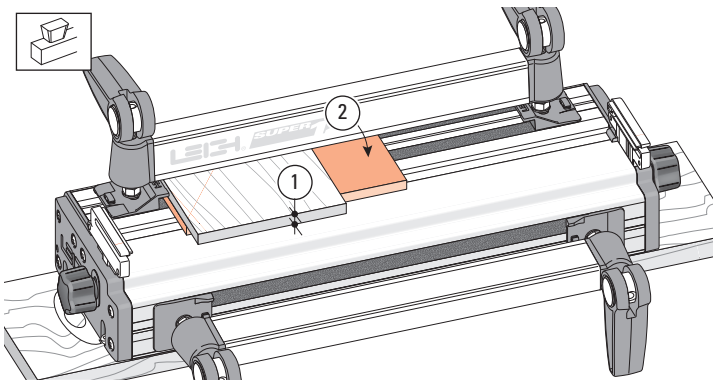

10-12 If you're mounting Thin Pin Boards:

Minimum recommended pin board thickness is 1/2" [13mm]. Remember, No.128-8 bits rout at 3/8" [9,5mm] deep. If you rout a pin board less than minimum thickness ①, you need to pack the board up from the jig body. We suggest a piece of 1/4" to 3/8" [6 to 9mm] plywood for this purpose ②.

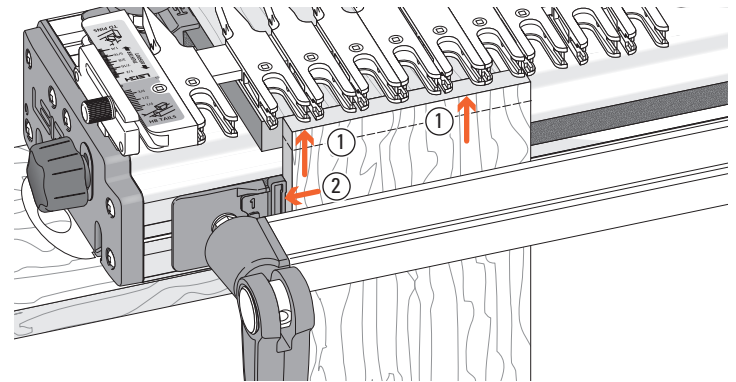

10-13 Re-set the drawer side in the front clamp so that its top edge touches the guide fingers and is **perfectly flush** with the top face of the drawer front ① and the left edge is against the Spacer ②.

! Board edges must be square.

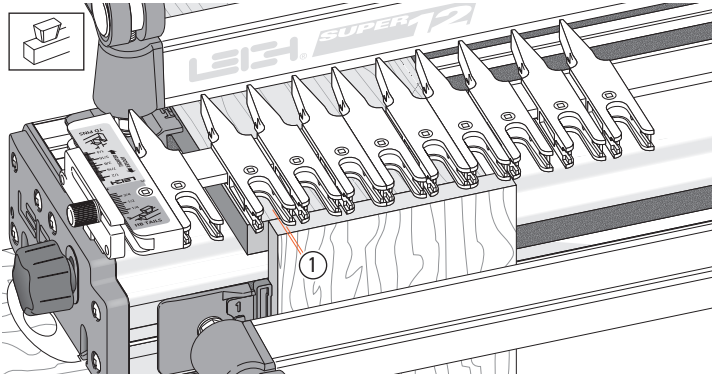

10-14 With the scale set on $\frac{1}{2}$ " [12,7mm], raise the finger assembly about $\frac{1}{16}$ " [2mm] above the drawer front ①. The scale is always set on the $\frac{1}{2}$ " mark when using the stop rod. See 10-26 for *Drawer Sides (Tail Boards) thicker than $\frac{5}{8}$ "*.

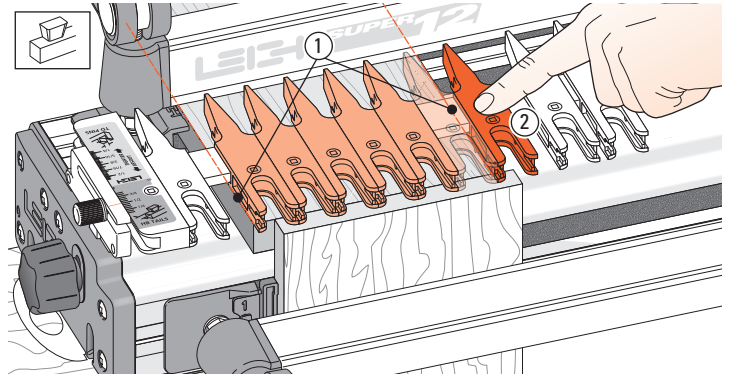

10-15 Slide across enough guide fingers to cover the **drawer front width**. Position fingers tight together and center the group of fingers on the board ①.

Depending on the exact board width, the outer fingers will either overhang, be inside, or flush with the board edges. Now add one more finger to the right of the group ② for routing the drawer side.

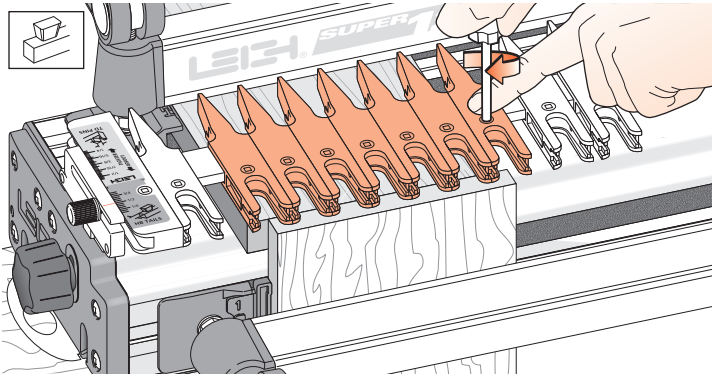

10-16 Tighten the finger's screws. Move any spare fingers so that they will support the router and **tighten all loose fingers**. Lower the assembly flat onto the two work pieces.

 **REMEMBER SAFETY!**

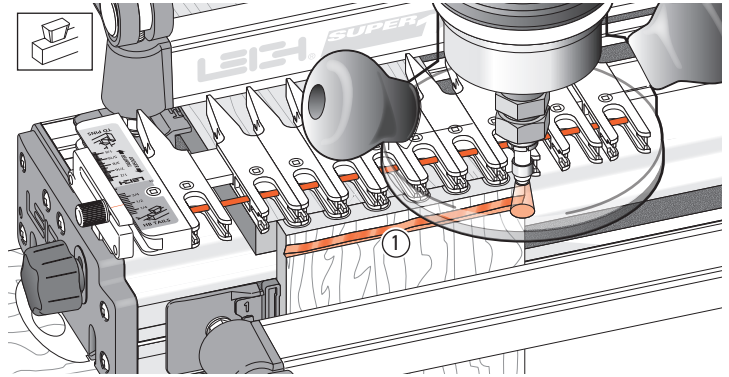

10-17 Insert the Stop Rod through the fingers.

For the first light cut move the router from right to left. Make sure you control it firmly, because it is driven in this direction by the bit. Only the tip of the bit should be cutting on the first cut ①. This back, or climb routing, leaves a very clean shoulder when routing side grain.

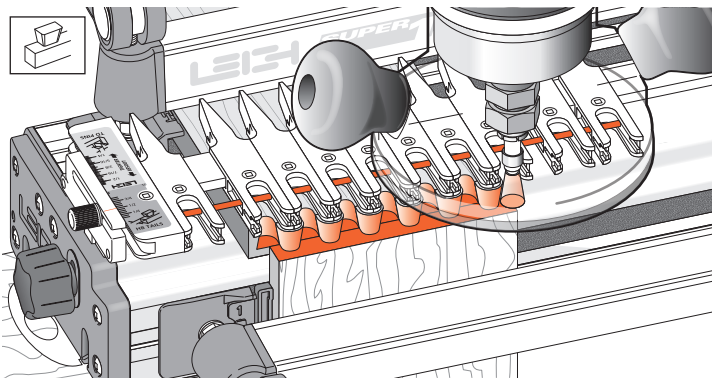

10-18 Now rout in and out from left to right. Follow the guides into each finger opening to touch the stop rod. The pins, tails and sockets are formed simultaneously.

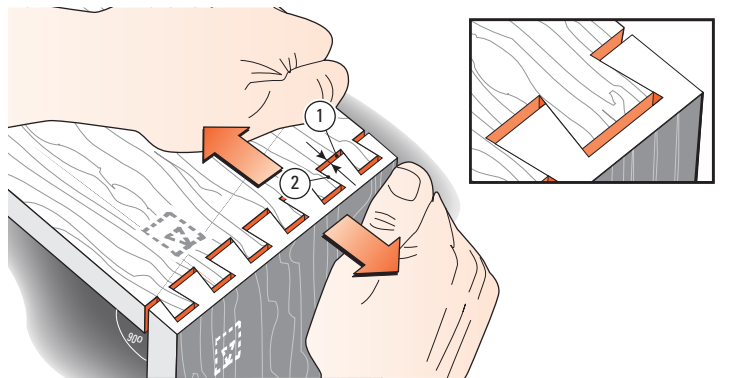

10-19 Remove the boards and test the joint for fit. If the joint is **loose**, as shown here, **lower** the bit by the same amount as the gap at the bottom of the pins ① when the pins are pulled against the socket sides ②. If the joint is too **tight**, raise the bit slightly. Test again. You cannot rout the same board ends again with a dovetail bit, so use two fresh ends for each test.

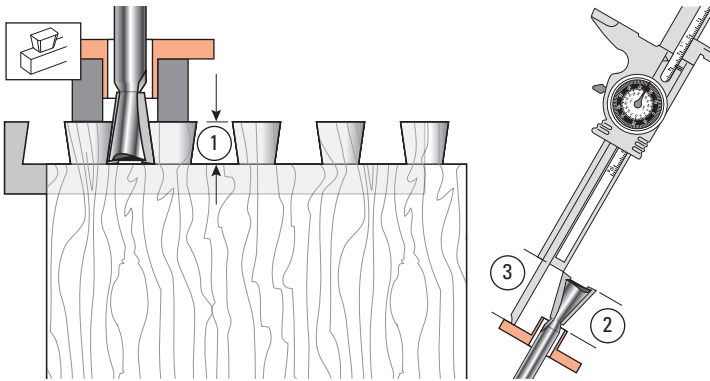

10-20 Keep the test tail board that fits well, and mark it with the number of the bit you used to rout it. For quick set-up next time, clamp this tail board in the jig as a *depth-of-cut gauge* ① to show how far to lower the bit. Better yet, measure the bit projection from the end of the guidebush ② or guidebush flange ③ and record this for fast set-up in future.

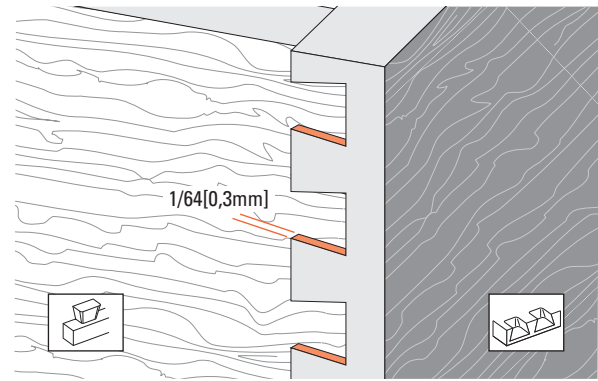

10-21 When you have the proper tightness of fit, check the flushness. The tails should be under flush to the pins by *no more than 1/64" [0,3mm]* to allow for cleanup (exaggerated here). Any concentricity errors in the collet and guidebush on different routers will affect this tolerance.

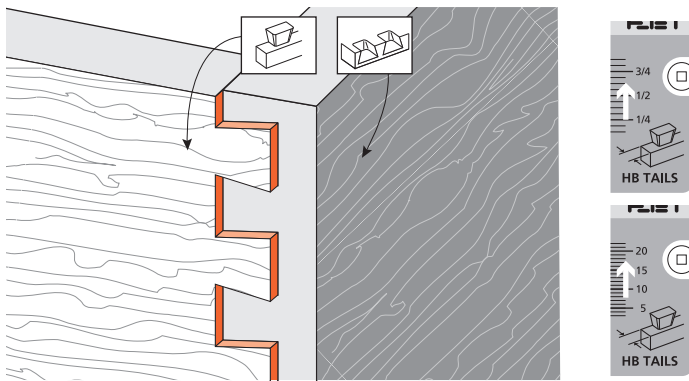

10-22 If the tails stand out from the pins, set the HB TAILS scale away from the operator by half the amount required.

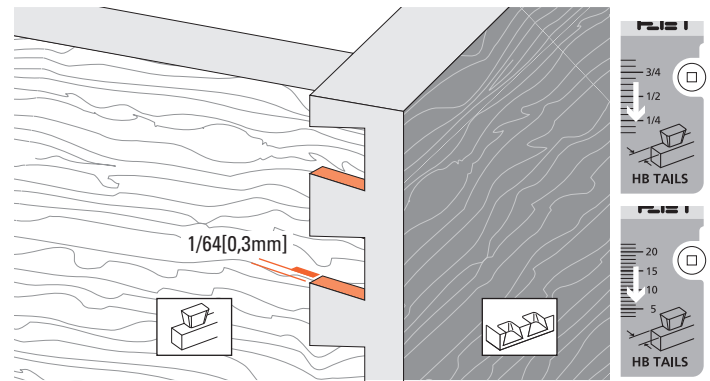

10-23 If the tails fit in too far past the pins ends, set the HB TAILS scale toward the operator by half the amount required.

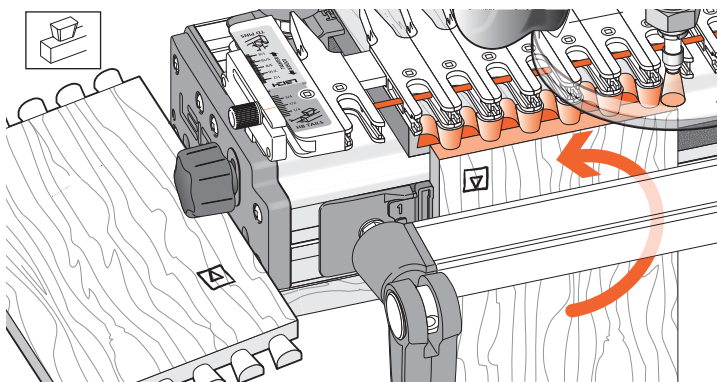

10-24 To make a box, repeat the procedure four times, ensuring that the drawer fronts, rears and sides are all rotated correctly in the jig, keeping the inside face □ of the boards away from the jig.

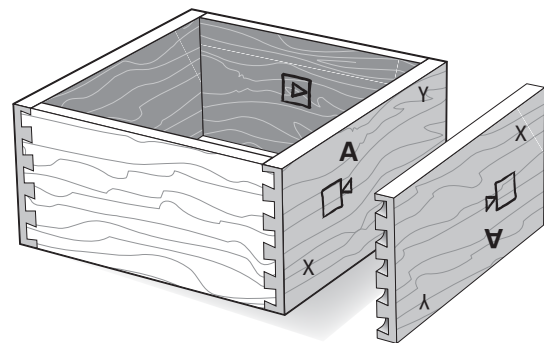

10-25 Assemble the drawer. As with through dovetails, it doesn't matter which edge of any of the boards are at the top or bottom, the drawer will still fit together e.g. pin board "A" can be up either way.

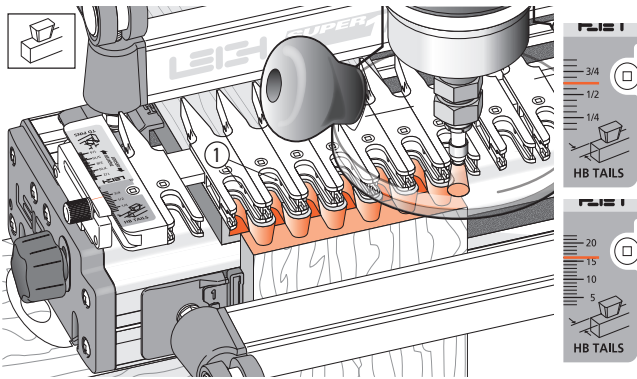

10-26 Tail Boards $\frac{5}{8}$ "[16mm] and thicker.

Use the same procedure to rout "single pass" dovetails with side thicknesses from $\frac{5}{8}$ " to 1"[16 to 25mm] **except:**

The stop rod is not used ① and the initial scale setting is $\frac{5}{8}$ "[16mm] for all boards ②. *Hint: Set the e7-Bush to lower than 10 for deeper cuts in drawer fronts.* ■

Rabbeted Half-Blind Dovetails

Before attempting rabbeted half-blind dovetails, first master the techniques of flush half-blind dovetails in Chapter 9, Variably Spaced Half-Blind Dovetails.

Note: Rabbeted half-blind dovetails cannot be routed in a single pass – the lip of a drawer front makes it impractical, as each piece would have to be routed separately, in which case it is easier to use the variably spaced method.

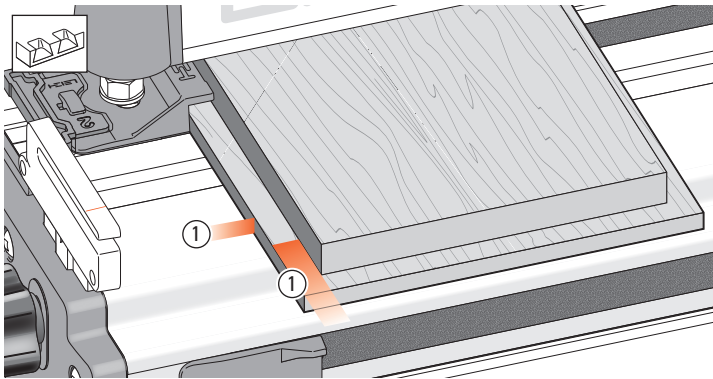

11-1 Provided the drawer front lip is $\frac{3}{8}$ " [9,5mm] or less in each direction ①, you can mount and rout rabbeted drawer fronts and sides exactly the same way as flush drawer fronts, except...

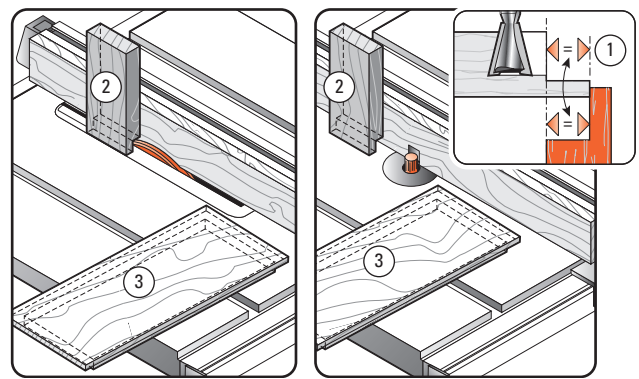

11-2 Rabbeted Pins You will need to block the scrap stop in the front of the jig out from the jig's front face by exactly the width of the rabbet ①.

An easy accurate way to do this is to rabbet the end of the scrap piece ② vertically over a dado blade or router bit at the same time as you rabbet the drawer front (horizontally) ③.

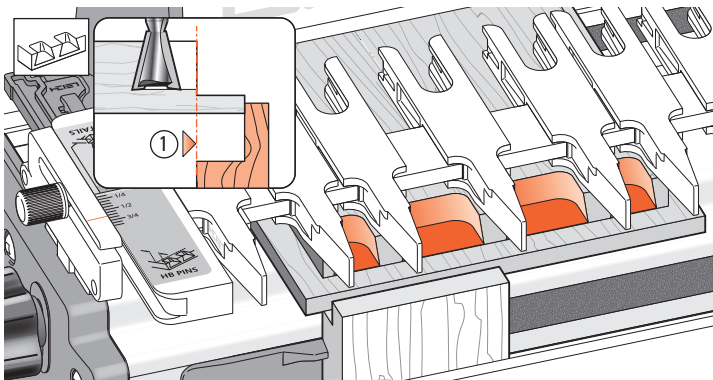

11-3 This brings the pin ends exactly in line with the front jig face ①, ensuring that the scale reading is accurate.

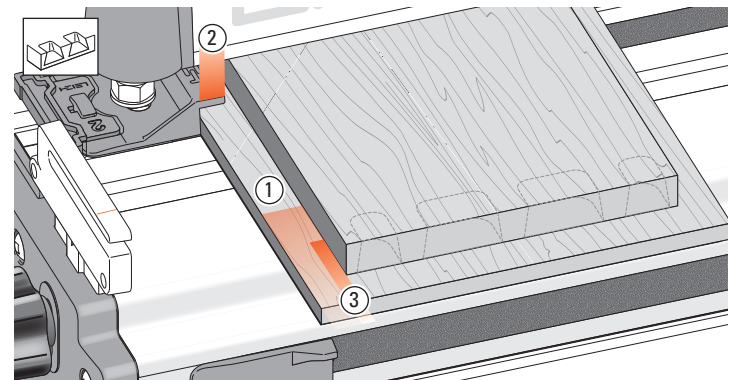

11-4 If the rabbet width ① is greater than the top side stop width of $\frac{3}{8}$ " ②, the drawer side (tailboard) must be blocked away from the front side stop (see 11-5) by exactly the width of the rabbet minus $\frac{3}{8}$ " ③. For example, a $\frac{5}{8}$ " rabbet ① would require the tailboard to be offset by an additional $\frac{1}{4}$ " ③.

Make a spacer block of the required width and...

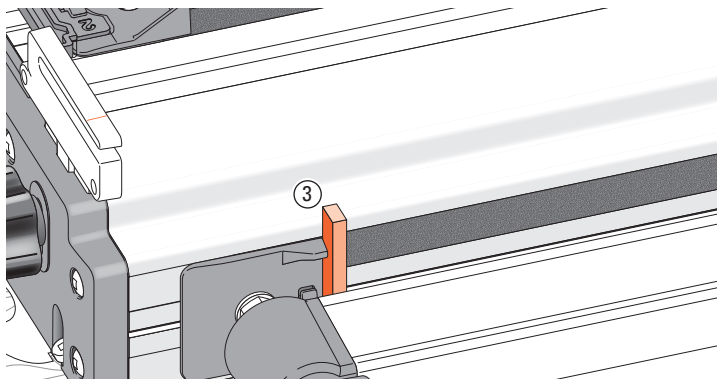

11-5 Stick the block ③ to the jig face with double-sided tape, making sure it touches the side stop.

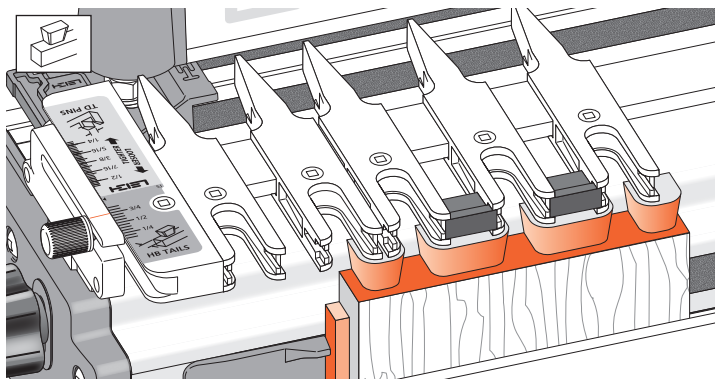

11-6 The drawer side will now be stepped in from the side stop by the width of the rabbet, bringing the sockets in line with the pins.

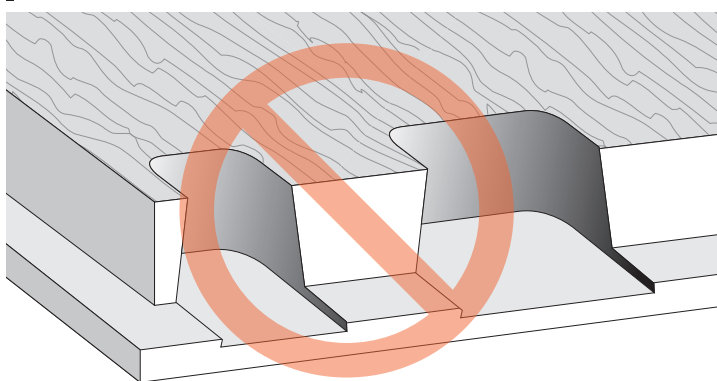

11-7 Make sure you select a dovetail bit that has a working depth of cut less than the rabbet height. Otherwise, you will rout into the rabbet.

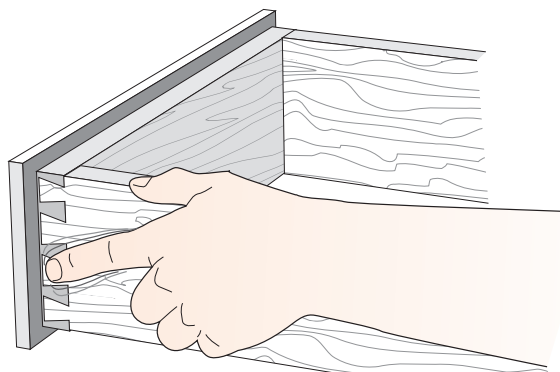

11-8 It is difficult to clean up the drawer sides and front corner after assembling a rabbeted drawer, so make sure the fit is flush before you complete the drawers See 9-28 to 9-30. ■

Asymmetric Dovetails

For certain procedures, you will need to use both ends of the Leigh Superjig Jig. Asymmetrical joint layouts are one example. On the Superjig, no joints will be truly symmetrical, but they can **look** symmetrical. Apparent symmetry is desirable for aesthetic reasons, but is not required for strength. Be sure you have read and understood chapters 8 through 10 before attempting these procedures.

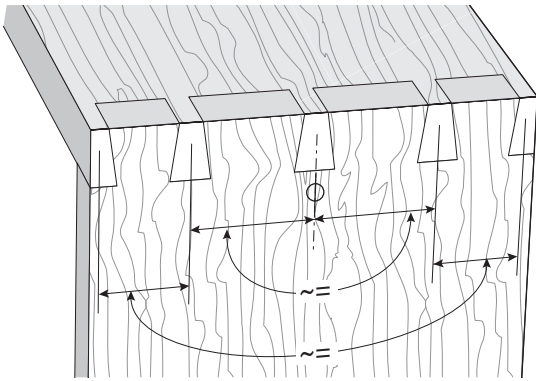

12-1 By *symmetrical* we mean a joint that looks or is approximately symmetrical about its center line but is probably not, and need not be precisely symmetrical. Using the Leigh jig, it is easy to cut a joint that looks symmetrical; the pins will always align perfectly with the tails cut at the same spacing. Remember, symmetry is only required for appearance, not for joinery reasons.

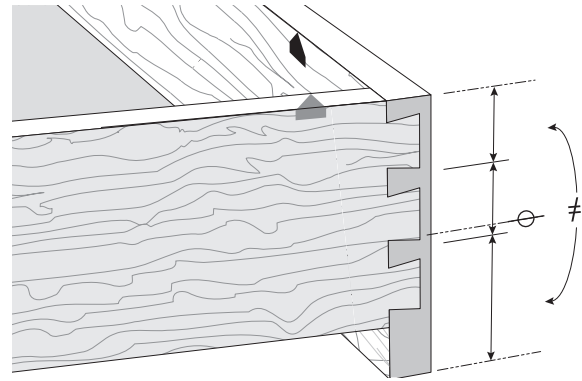

12-2 An *asymmetrical* joint has a deliberately uneven layout of pins and tails desired for a project design; for example, this drop-front drawer. The half-pin at the bottom of the drawer is much wider than the top half-pin. As the top edges of the front and sides are flush, it makes sense to use these edges against the side stops at each end of the jig. Here's how.

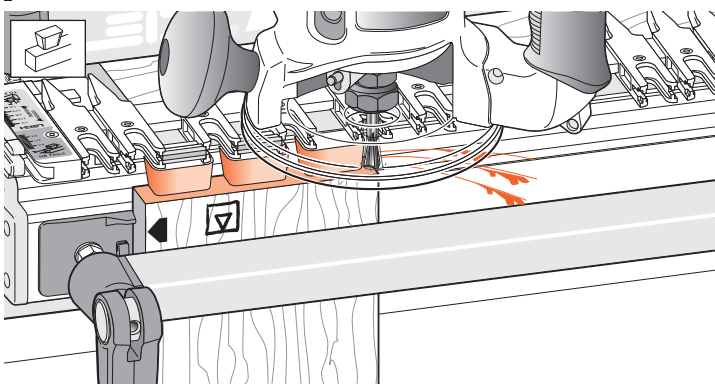

12-3 Mount the right-hand drawer sides and pins on the left end of the jig for routing, and...

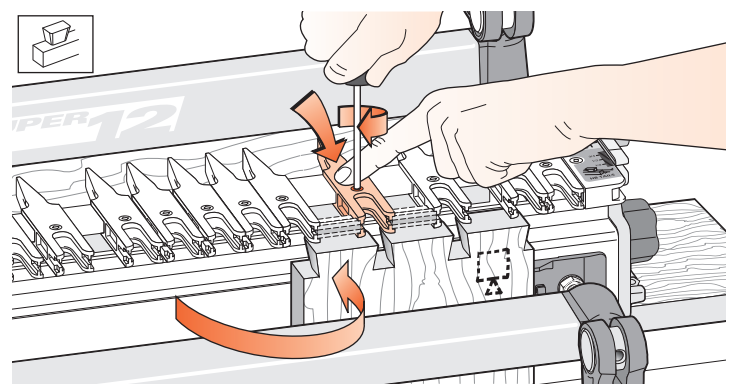

12-4 Turn one tailboard (like turning a page in a book) to the right end of the jig. Now lay out the fingers at the right end to match the sockets already routed. Now simply rout the left front corner (tails and pins) on the right side of the jig.

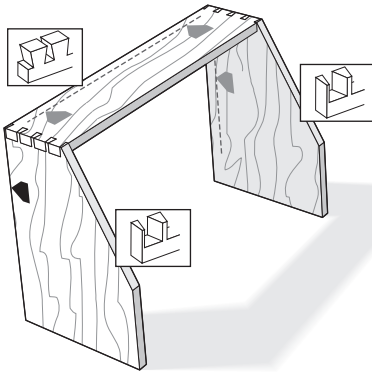

12-5 Another example of asymmetry is the top corners of a slant-front desk. The joints themselves may be symmetrical, but they must be routed on opposite ends of the jig because the sloped front edges will not register accurately against the fixed vertical side stops.

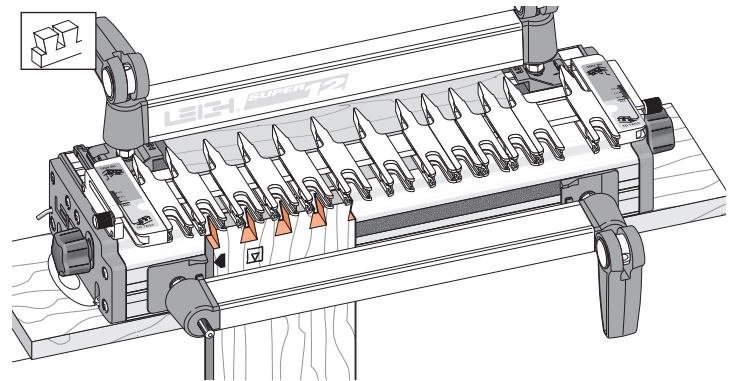

12-6 At the back of the desk both sides and top are flush, so the rear edges are set against the side stops. Place the left end of the top tail board against the left side stop ◀. Rout the tails.

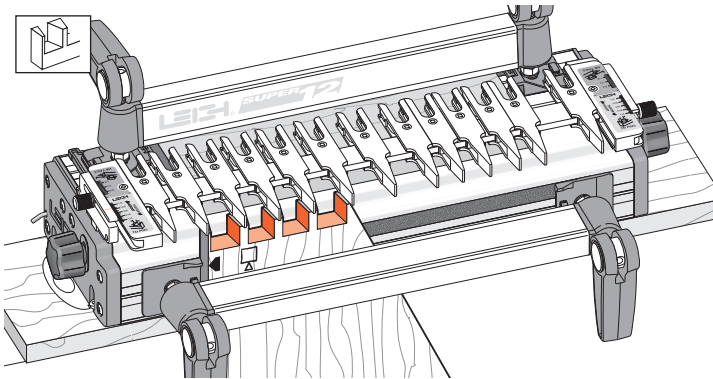

12-7 The left side of the desk goes against the left side stop ◀. Rout the pins.

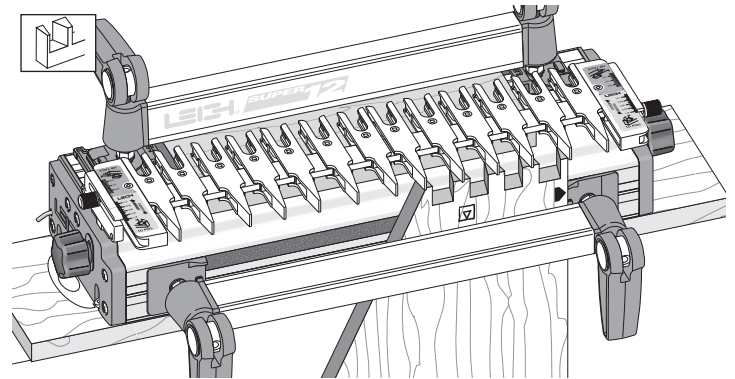

12-8 To lay out the joint at the right end of the jig, turn the left hand tailboard (like a book page) against the right side stop. Lay out the fingers over the pins you just cut.

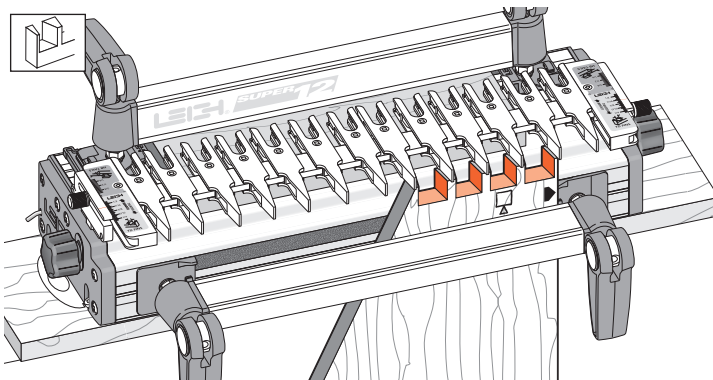

12-9 Place the right side of desk against the right side stop ▶. Rout the pins.

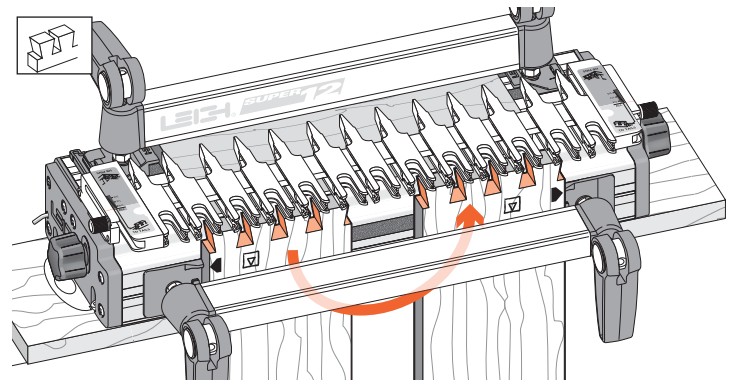

12-10 Rotate the finger assembly to TD Tails mode. Clamp the tailboard in the left side of the jig and rout the tails. Then rotate the board and clamp against the right side stop to rout the tails in the other end.

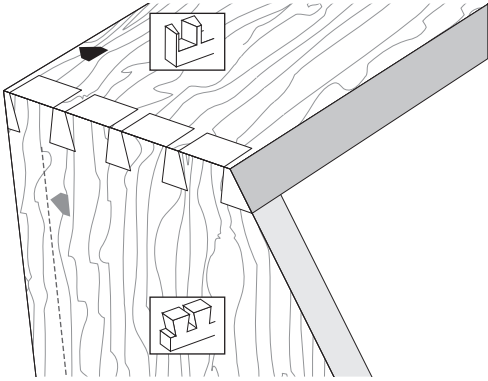

12-11 Note: If, in the slant-front desk example, the pins were in the desk top and the tails in the sides, then all the parts would be routed in the opposite ends of the jig to those shown in the previous steps.

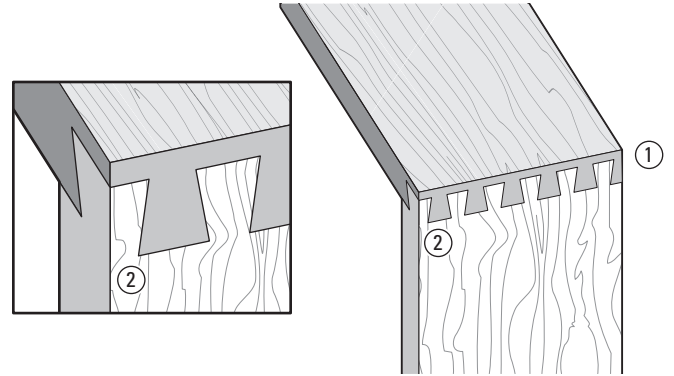

12-12 Asymmetric "Single Pass" Dovetails

Single pass dovetails become asymmetrical when a board width falls **between** joint pitch dimensions on the board width chart, page 40. Joint side edges will have a proper half pin on one side ① and an unattractive half-tail on the other ②. It is preferable to design drawer openings to suit the board width chart dimensions.

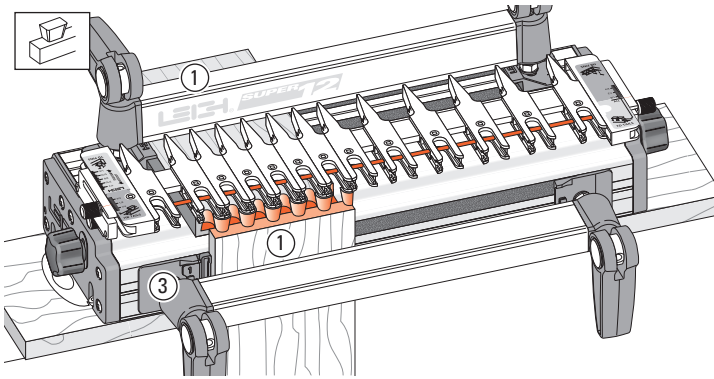

12-13 However, if this is not an option, the unattractive edge can be hidden from view at the bottom of drawers. Simply rout the right front and left rear drawer corners on the left side of the jig ①, and then...

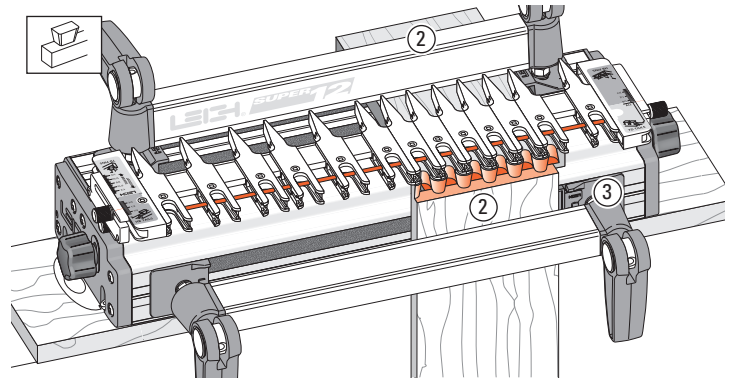

12-14 ...the left front and right rear drawer corners on the right side of the jig ②. The Spacer is used to offset the drawer sides at both ends of the jig ③. ■

SUPERJIG - CHAPTER 13

Sliding Dovetails

1 With the Finger Assembly in **HALF-BLIND DOVETAIL TAILS (HB TAILS) mode**, install the cross-cut fence

Sliding Dovetail slots are cut across the board face.

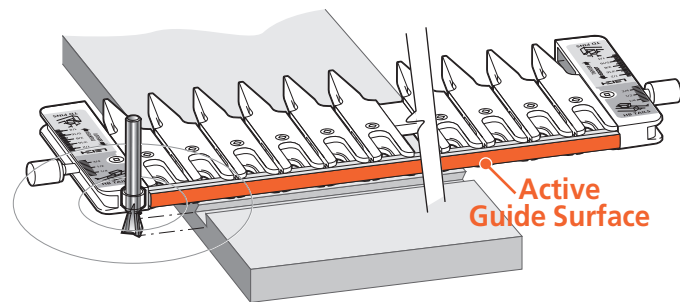
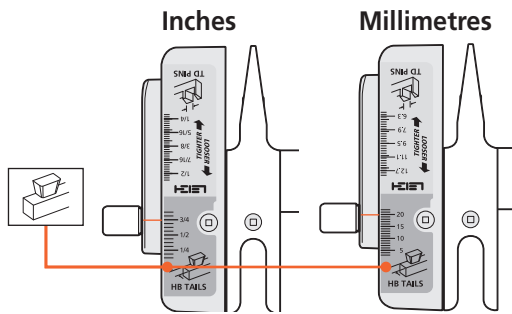

2 KEEP the finger assembly in the same mode

3 Sliding Dovetail tails are cut across the board end edge

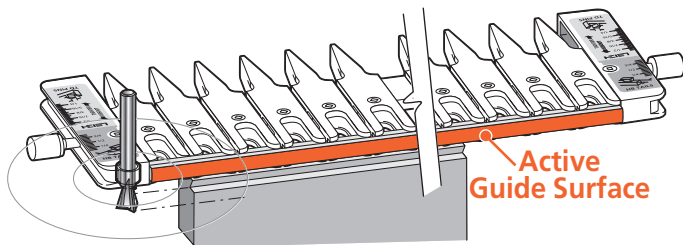
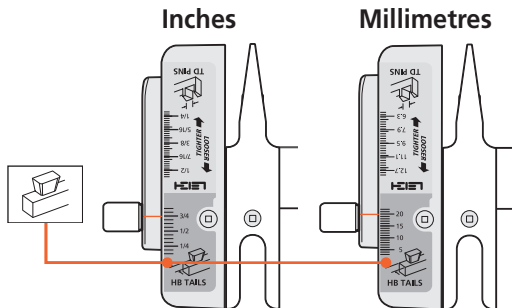

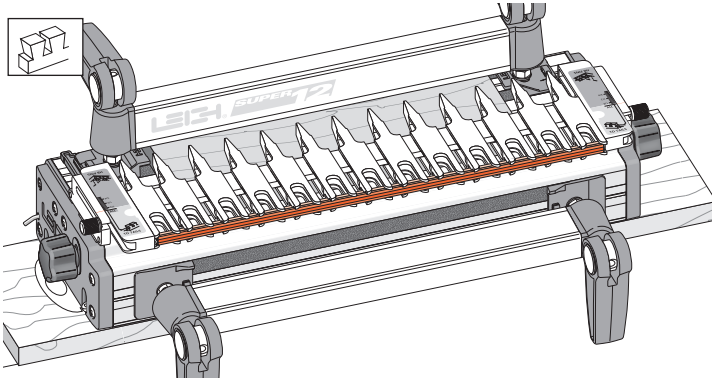

13-1 With the finger assembly in the  HB TAILS mode, the cross cut fence fits into the recesses in the ends of the tail guides to allow routing of sliding dovetails.

 Space the guides fairly evenly across the jig and firmly seat the fence into end of each guidefinger to ensure a straight cut.

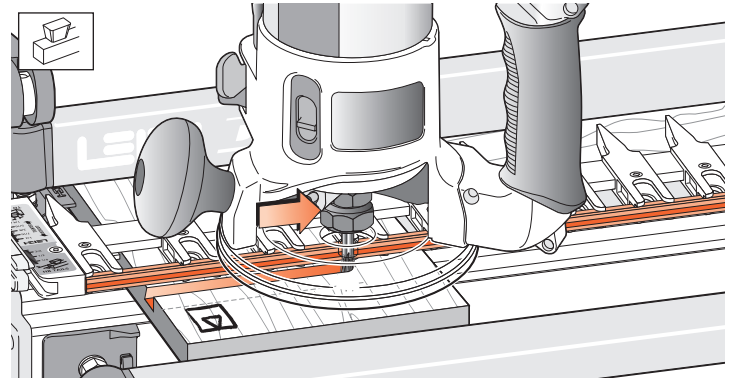

13-2 Using the cross cut fence as a guide surface for the guidebush, you can make lateral router cuts across the faces of horizontal boards (dovetail *slots*), and...

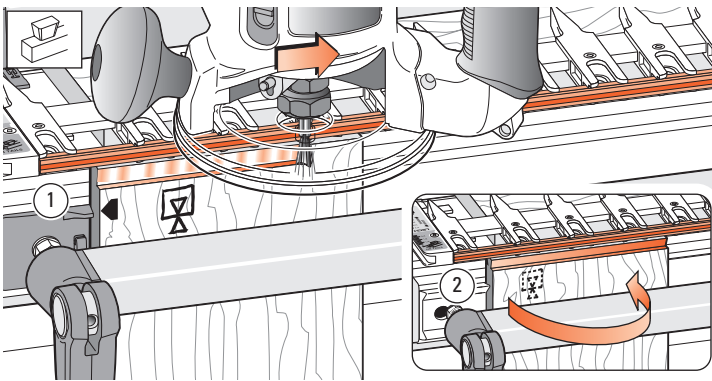

13-3 Across the top ends of vertical boards to cut the tails. First rout one side ①...

Then turn the board side-over-side to cut the other half of the tail ②.

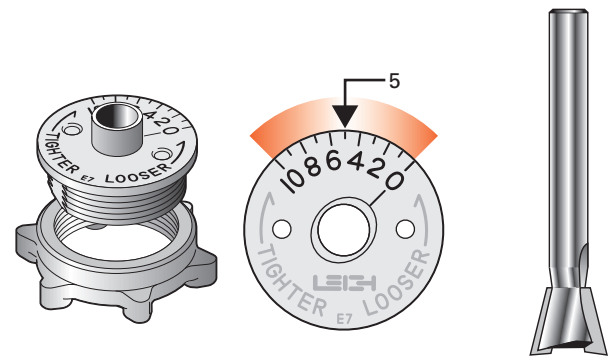

13-4 Turn the e7-Bush to “5” and use the No. 120-8, 1/2" x 14° bit for sliding dovetails. This e7-Bush setting will allow for fine fit adjustment later.

A standard $\sim 7/16$ " [11,1mm] guidebush (min. depth 1/4" see page 67) can be used but without the fine adjustment provided by the e7-Bush.

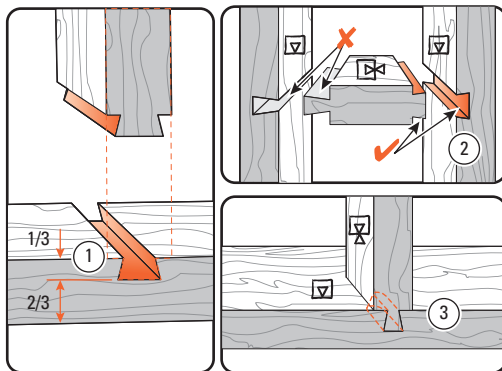

13-5 On a full width joint, the slot depth-of-cut should be no more than 1/3 the board thickness ①. If the tail board is a load-bearing horizontal member (e.g., bookshelf or step), make the tail fairly thick for good tail neck strength ②. Shorter sliding dovetails for less structural demand may be slightly deeper, with narrower profiles, especially if appearance is important ③ (e.g., where narrow rails join wider boards).

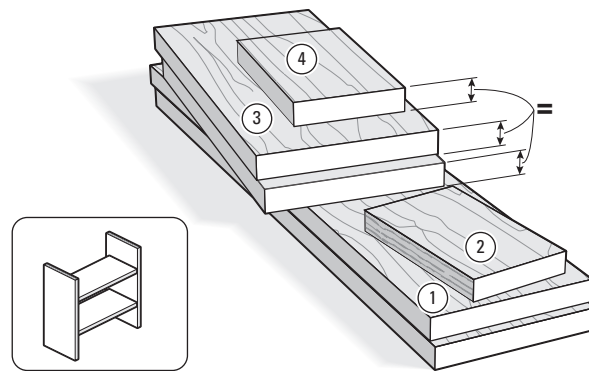

13-6 Use 3/4" x 5 1/2" [20x140mm] softwood to make two slot boards ①, plus one narrow test slot board ②, two tail boards ③ and one narrow test tail board ④. The tail boards ③ and test tail board ④ must be exactly the same thickness. This will make two uprights and two shelves.

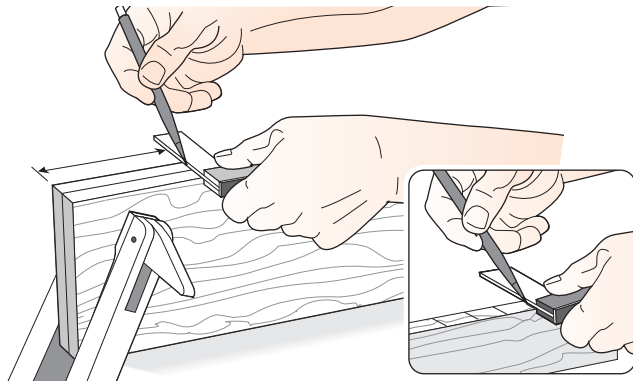

13-7 Marking Out: Do not mark the slot positions on the board faces. Mark the edges of both slot boards **together** for perfectly level shelves. Stay at least 7" [180mm] in from the ends for clamping on this test project. 13-25 describes how to rout close to both ends. Mark the narrow test slot board in the same way at several closely spaced random spots. This board is used only for setup.

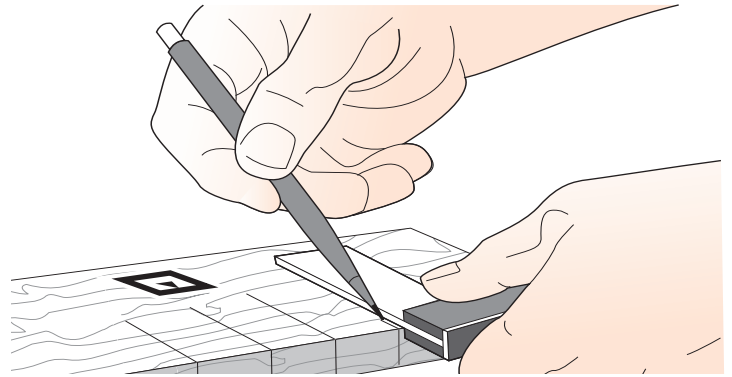

13-8 On the test slot board only, square the marks across the face.

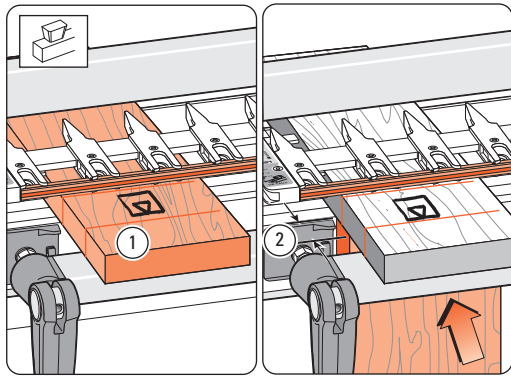

13-9 Mount the test slot board in the rear clamp, markings up ①. Mount a $\frac{3}{4}$ " [20mm] thick ② square-ended board vertically in the front clamp against the side stop, with the top edge butting the underside of the test board (yes, the $\frac{3}{4}$ " [20mm] thickness is important).

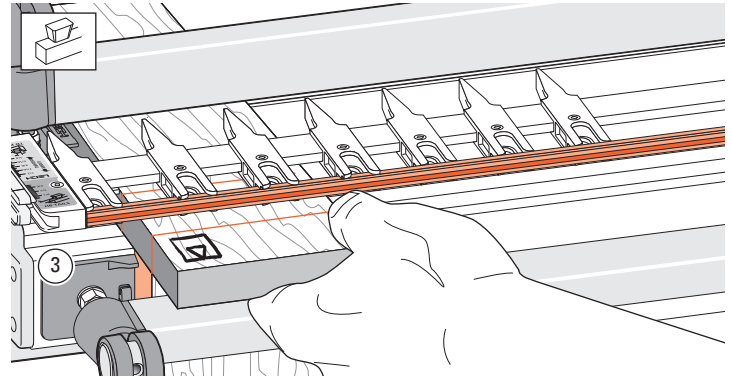

13-10 Position and clamp the test board so that one of the edge marks is in line with the *outside edge* of the vertical board ③.

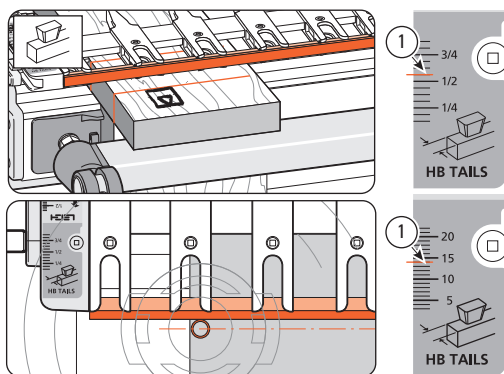

13-11 With the finger assembly (including the cross cut fence) on the support brackets in the HB TAILS mode, set the scale to $\frac{1}{16}$ " [14mm] ①. The routed slot will be close to centred on the slot line. Make sure the finger assembly is level and sitting flush on top of the board.

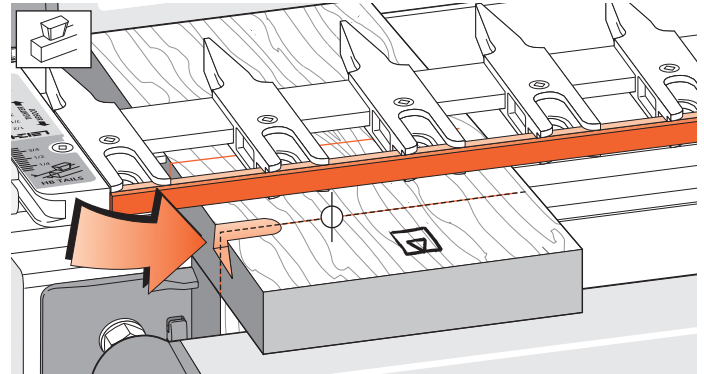

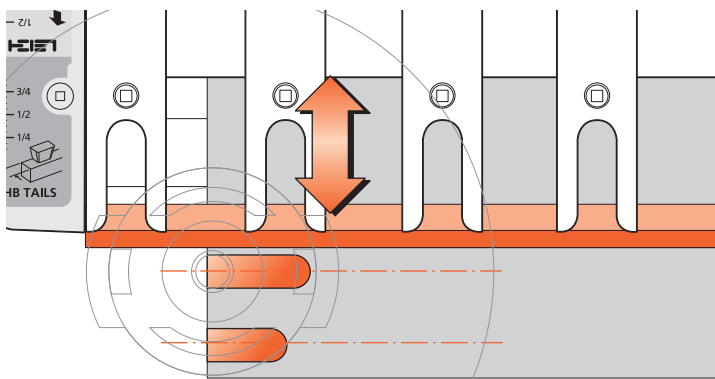

13-12 Adjust the bit so the cut depth is about $\frac{5}{16}$ " [8mm]. Rout from left to right maintaining light inward pressure of the guidebush on the fence. Rout in only about 1" [25mm] and back out again.

⚠ Do not lift the router.

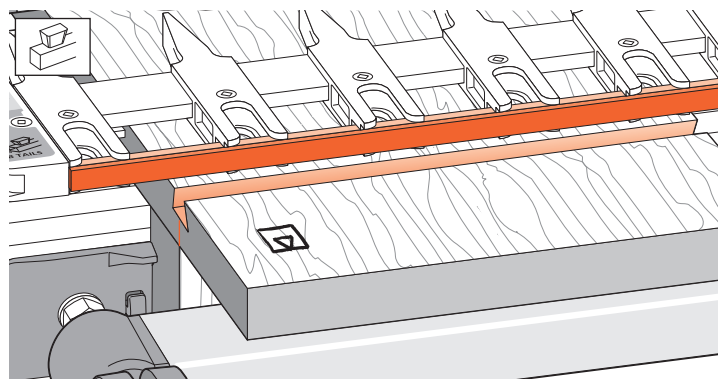

13-13 Check to see if this short slot is centred on the pencil line. If not, adjust the finger assembly in or out and re-test on the other lines as necessary until the slot is centred. Lock the finger assembly in this position and record the setting for future reference.



13-14 Now rout sliding dovetail slots in the two main slot boards with the boards in the horizontal position in the rear clamp, slot side, that is inside face  up. The guidefingers must be flush on the board.

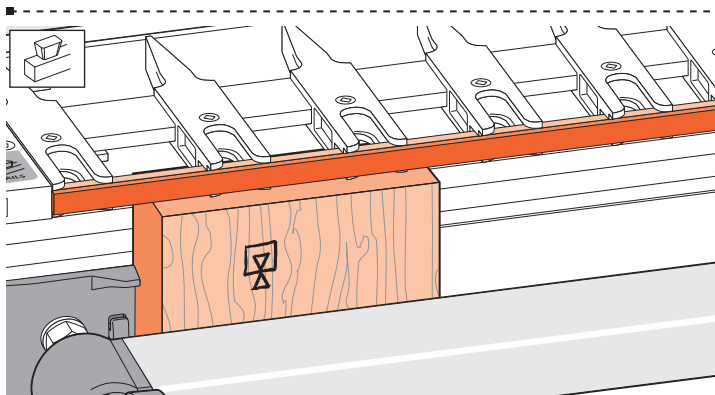

13-15 Replace the spacer board in the rear clamp, and with the finger assembly on the spacer board, mount a test tail board vertically in the front clamp, flush under the guidefingers. Either side can face out .

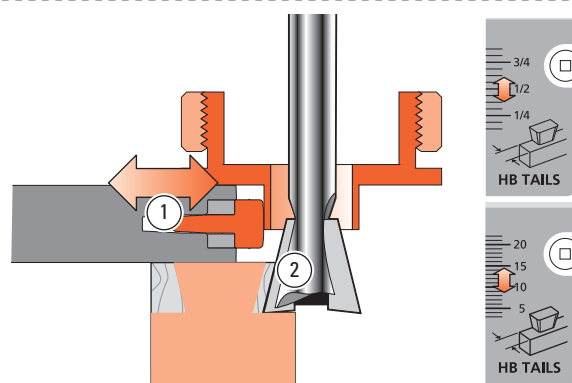

13-16 The  HB TAILS scale is not designed for this mode, but it does allow you to make quick adjustments for tail size and joint fit on sliding dovetails. Adjust and set the finger assembly ① so it is clear that the routed tail ② will be too large for the slot.

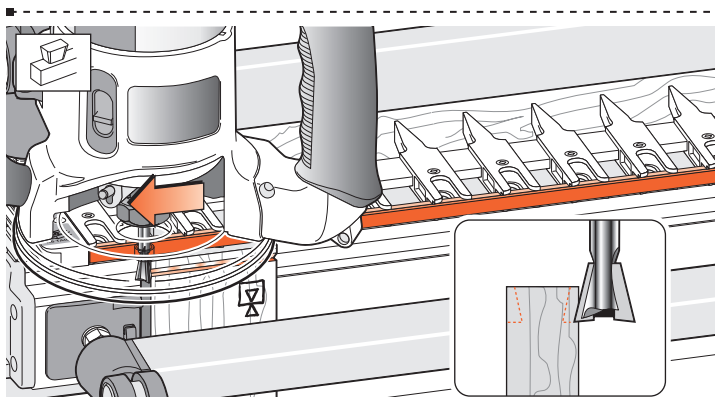

13-17  Rout one side of the test tail board. Make one light pass from right to left (climb routing). Make sure you control it firmly, because it is driven in this direction by the bit. Only the tip of the bit should be cutting on the first cut (see inset). This *back* or *climb* routing leaves a very clean shoulder in side grain.

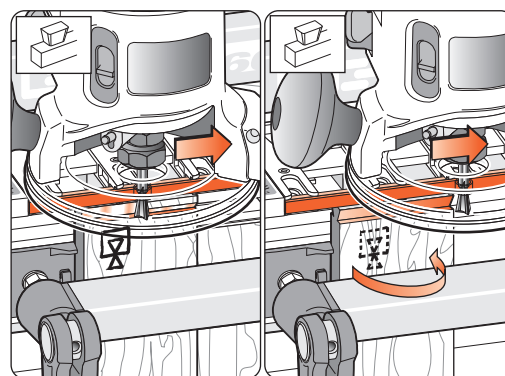

13-18 Finish left to right, with the guidebush touching the fence. Turn the test tail board around in the jig and rout the other side in the same manner.

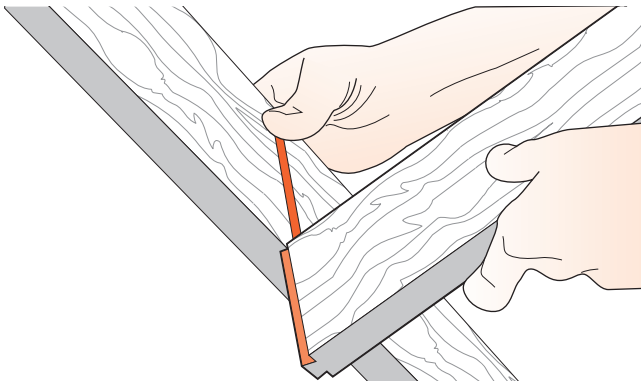

13-19 Test the joint for fit. The tail should be too big. If it is too small, adjust the finger assembly outward by at least half the difference and rout another test tail on the other end of this test board.

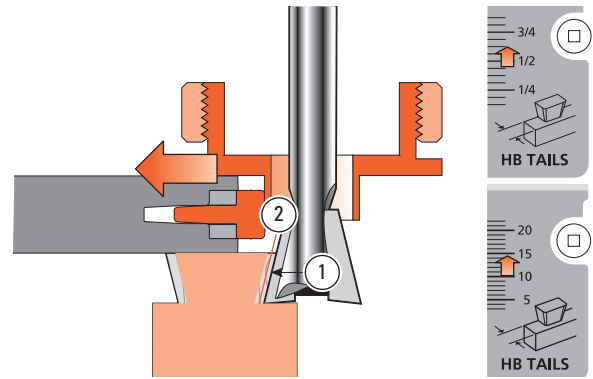

13-20 If the tail is too wide ① move the finger assembly in toward the jig by half the amount the tail is too wide ②. Rout the same test board again. Adjust and re-test until fit is slightly loose or slightly tight.



13-21 Note: the e7-Bush fit adjustment for sliding dovetails works reverse to normal. Fit adjustments are made by adjusting the tail size only, not the socket. The e7-Bush is turned down to a lower number for a tighter fit, and up to a higher number for a looser fit. Each increment changes the glue line fit by 0.001" [0,025mm] When the fit is satisfactory, rout one end of a project tail board and test again. If the fit is good, rout all tail board ends.

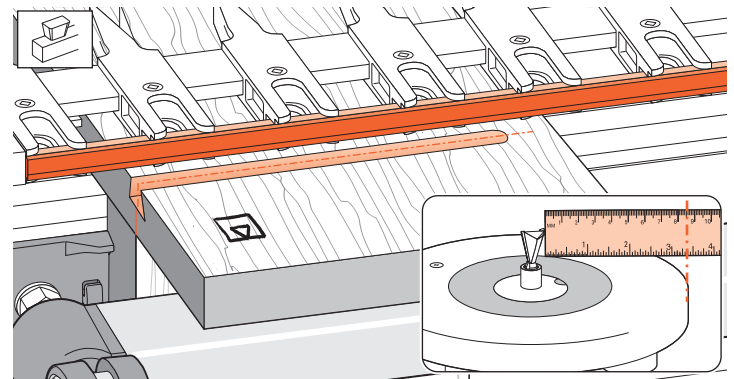

13-22 Stopped Sliding Dovetails

If a stopped sliding dovetail is called for...

Measure from the outside tip of the dovetail bit to the edge of the router base.

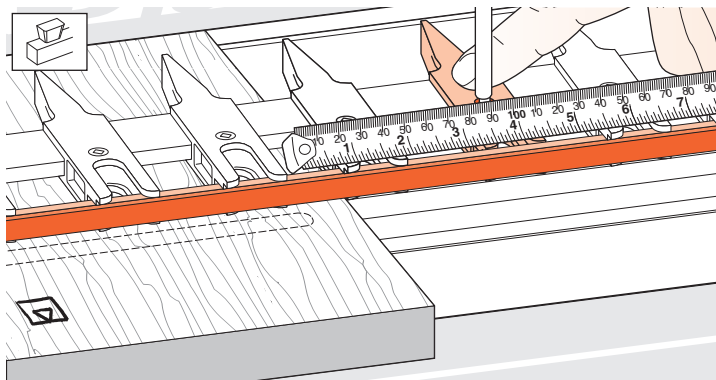

13-23 Measure the same distance from where you want the slot stopped to a position on the finger assembly. Move a guidefinger to that point and mark the guidefinger with a felt pen as a visual router stop mark...

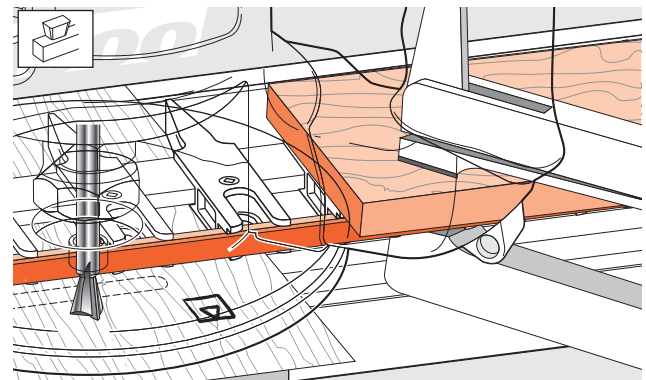

13-24 Or lightly clamp (with a soft-jawed clamp) a short board to the finger assembly to act as a router stop.

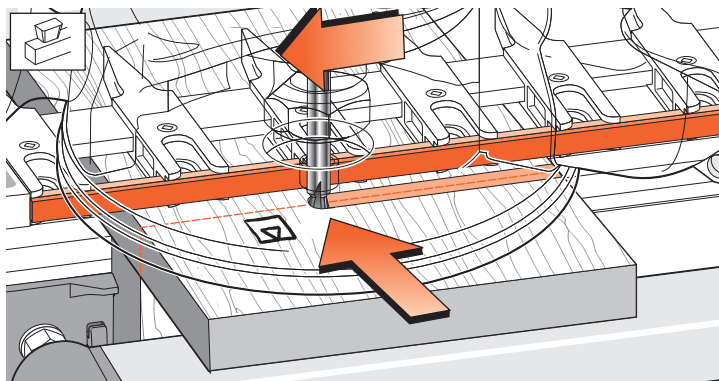

13-25 ⚠ Dovetail slots preferably are routed from left to right because the bit's clockwise rotation pulls the guidebush against the fence. However; as when routing close to both ends of a board, it may be necessary to rout slots from right to left. **Bit rotation** will tend to pull the router away from the fence. Feed slower and maintain constant guidebush pressure against the fence. ■

Box Joints

Actual Joint Sizes

The Superjig finger assembly was originally designed solely for dovetailing. Adapting the assembly for box jointing was a serendipitous combination of luck (existing guides approximately the correct dimension) and clever design; the e7-Bush and Spacer.

So the nominal $\frac{5}{16}$ " and $\frac{5}{8}$ " [8 and 16 mm] box joint sizes are actually $\frac{21}{64}$ " and $\frac{21}{32}$ " [8,3 and 16,7mm] respectively.

Concept of Operation

The first board is set against the side stop ①.

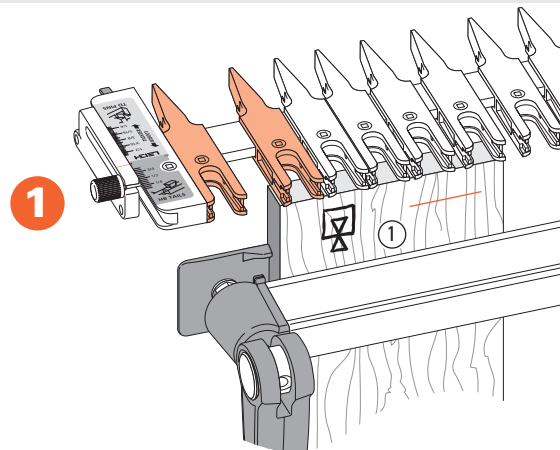

The Spacer is used to space the guide fingers ②.

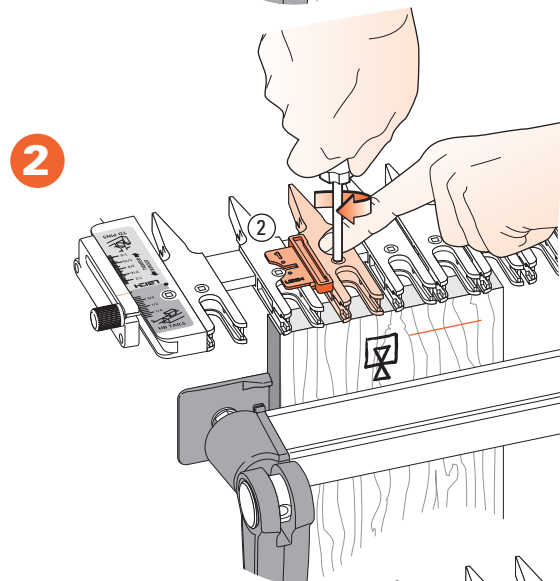

The Spacer is also used on the side stop ③ to accurately offset mating work pieces for correct board to board joint alignment.

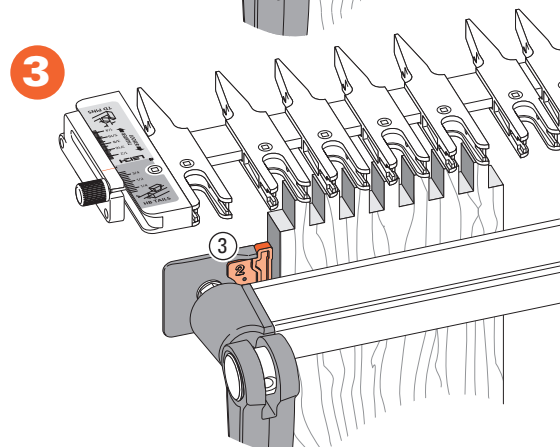

Choose your Board Width:

Choose a joint size from the chart below: 5/16" [8mm] or 5/8" [16mm].

For Symmetrical joint board widths: **Use the red column.**

For Asymmetrical joint board widths: **Use the grey column.**

The number in the first column (white) for each joint size equals the total number of pins and sockets for the board width in the **red** or **grey** columns.

Board Thickness

Joints may be routed in any board thickness up to 1 3/16". Boards of different thicknesses may also be joined.

Board Width - INCHES

Board Width - MILLIMETERS

5/16"		5/8"		8mm		16mm	
Pin/Socket width		Pin/Socket width		Pin/Socket width		Pin/Socket width	
Symmetrical	Asymmetrical	Symmetrical	Asymmetrical	Symmetrical	Asymmetrical	Symmetrical	Asymmetrical
1		1		1		1	
2		2		2		2	
3	29/32			3	1 29/32	3	48
4		1 1/4		4		4	
5	1 9/16			5		5	
6		1 29/32		6		6	
7	2 7/32			7		7	
8		2 9/16		8		8	
9	2 7/8		2 9/16	9		9	
10		3 7/32		10		10	
11	3 17/32			11		11	
12		3 7/8		12		12	
13	4 3/16			13		13	
14		4 1/2		14		14	
15	4 27/32			15		15	
16		5 5/32		16		16	
17	5 1/2		5 5/32	17		17	
18		5 13/16		18		18	
19	6 5/32			19		19	
20		6 15/32		20		20	
21	6 13/16			21		21	
22		7 1/8		22		22	
23	7 15/32			23		23	
24		7 25/32		24		24	
25	8 1/8			25		25	
26		8 7/16		26		26	
27	8 25/32			27		27	
28		9 3/32		28		28	
29	9 13/32			29		29	
30		9 3/4		30		30	
31	10 1/16			31		31	
32		10 13/32		32		32	
33	10 23/32			33		33	
34		11 1/16		34		34	
35	11 3/8			35		35	
36		11 27/32		36		36	
37	12 5/32			37		37	
38		12 1/2		38		38	
39	12 13/16			39		39	
40		13 5/32		40		40	
41	13 15/32			41		41	
42		13 25/32		42		42	
43	14 1/8			43		43	
44		14 7/16		44		44	
45	14 25/32			45		45	
46		15 3/32		46		46	
47	15 7/16			47		47	
48		15 3/4		48		48	
49	16 3/32			49		49	
50		16 13/32		50		50	
51	16 3/4			51		51	
52		17 1/16		52		52	
53	17 13/32			53		53	
54		17 23/32		54		54	
55	18 1/16			55		55	
56		18 3/8		56		56	
57	18 11/16			57		57	
58		19 1/32		58		58	
59	19 11/32			59		59	
60		19 11/16		60		60	
61	20			61		61	
62		20 11/32		62		62	
63	20 21/32			63		63	
64		21		64		64	
65	21 5/16			65		65	

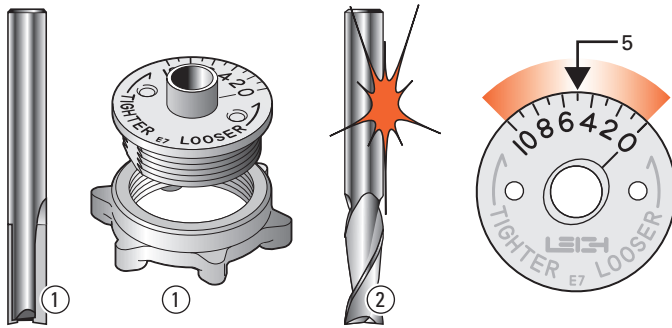

14-1 Bit and Guidebush selection Only the e7-Bush and $\frac{5}{16}$ " bit that came with SUPERJIG ① are required for all SUPERJIG box joints. Note: Spiral upcut router bits ② will cut cleaner than straight flute. Where metric size bits are available an 8mm straight or spiral bit may be substituted for the $\frac{5}{16}$ ". Always start test routing with the e7-Bush set on "5", the adjustment mid-range.

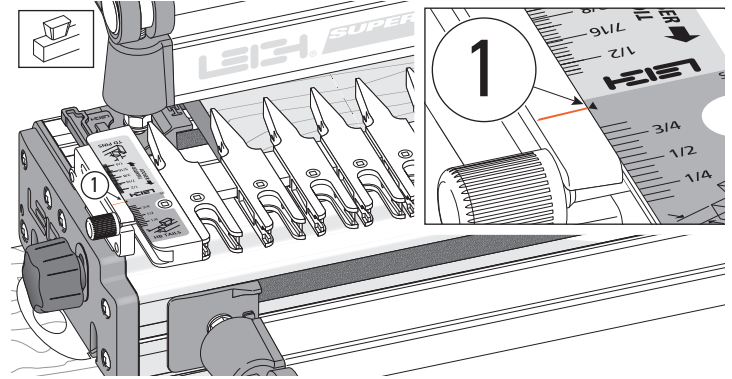

14-2 $\frac{5}{16}$ " [8mm] Box Joints.

Place the finger assembly on the support brackets in the HB TAILS mode, set the scales on the **small triangular arrow** ① and lower the assembly onto the spacer board.

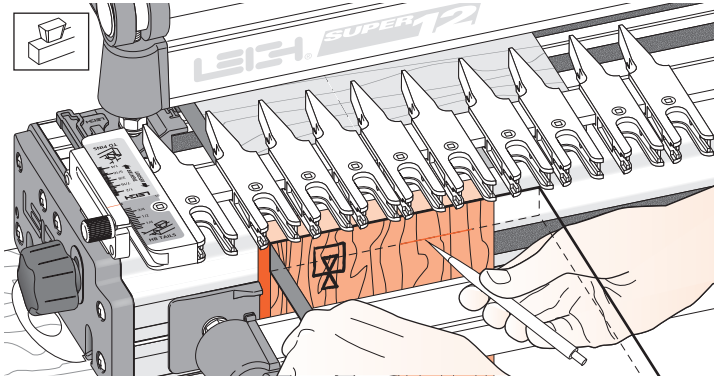

14-3 Clamp a test board in the front left clamp, against the side stop with the top edge flush under the guidefingers. The board may be clamped face side in or out. Mark and adjust the depth of cut to suit the thickness of the mating boards ①.

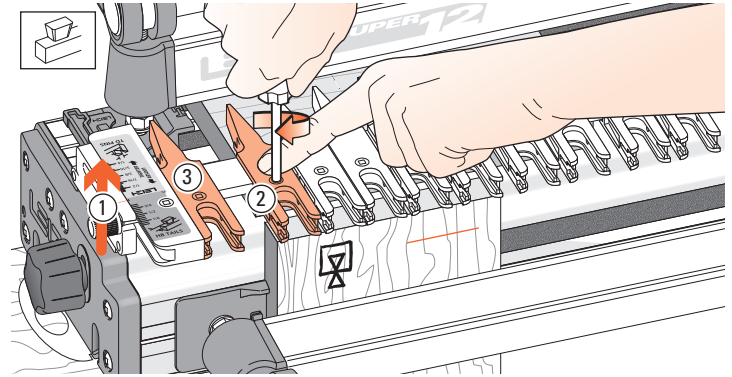

14-4 Raise the finger assembly about $\frac{1}{16}$ " [2mm] to allow ease of guide finger adjustment ①. Position the second guidefinger $\frac{1}{32}$ " [1,0mm] in from the board edge ② and tighten the finger. The first finger stays against the scale block as a router support ③. *Note: Square ended boards are essential to achieve flush joint alignment.*

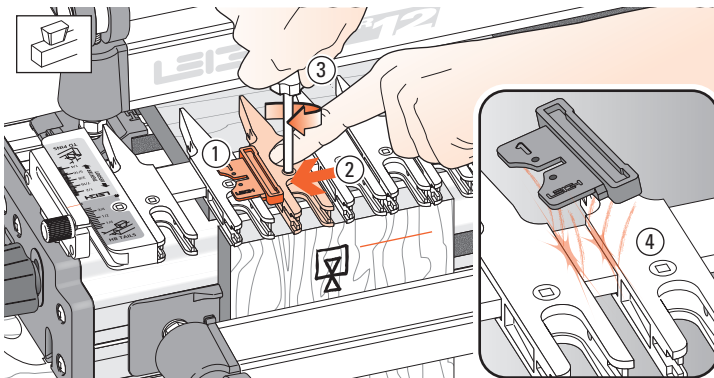

14-5 Place the Spacer on the finger bar to the right of the second finger, numeral 1 on top overlapping the locked finger ①. Move the next finger in to touch the Spacer ②. Hold the guidefinger firmly against the Spacer and tighten the second finger screw ③. As you remove the Spacer you should feel some friction; this indicates that the guidefinger is correctly spaced ④.

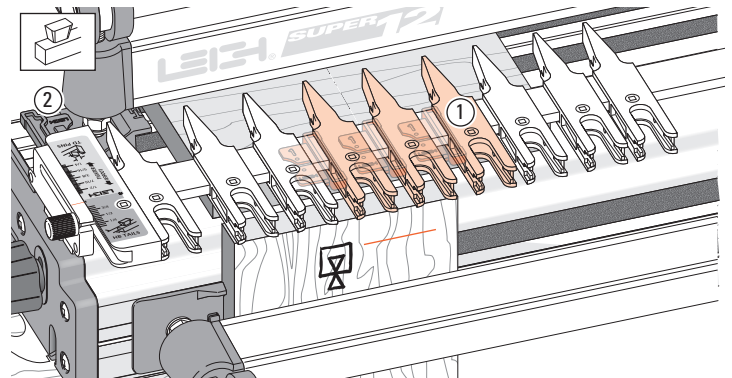

14-6 Repeat this procedure across the jig until there is at least one guidefinger spaced past the right side of the work piece ①. Tighten the unused guides. Store the Spacer on the outside of a rear side stop ②.

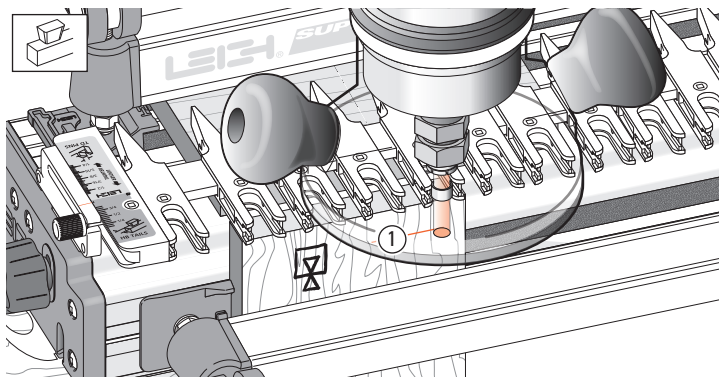

14-7 Lower the finger assembly onto the spacer board and double-check that the bit depth is down to the center of the pencil line ①. Make sure the collet does not rub on the guidebush.

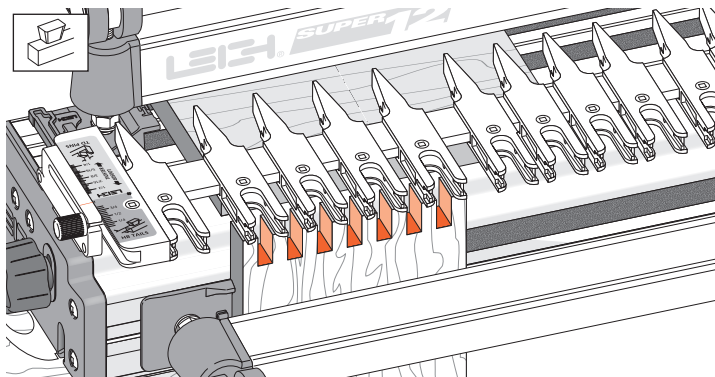

14-8 Rout one end of the scrap board. Rout into each finger opening and between each finger. Make sure to run the guidebush on both sides of each opening.

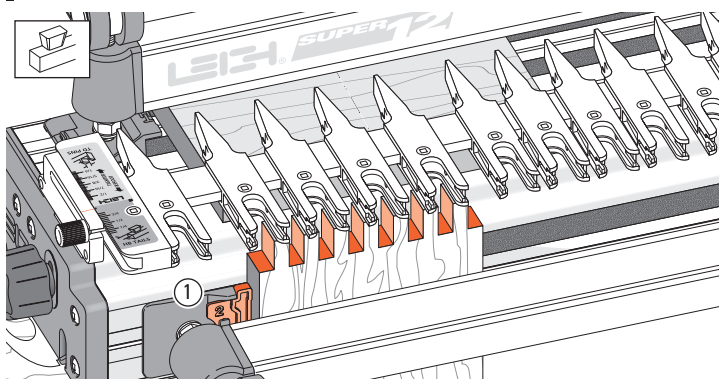

14-9 Remove the board and fit the SPACER to the front side stop with the **number 2 showing** ①. Make sure it is fully home. Clamp the second test board with its side edge against the Spacer and its top edge touching the guidefingers. Rout this board.
Note: Square ended boards are essential to achieve flush joint alignment.

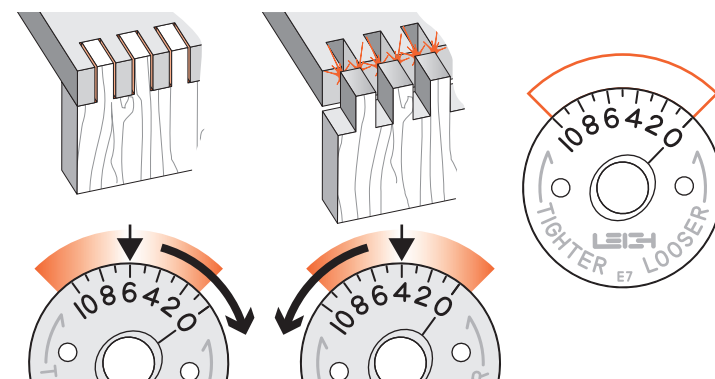

14-10 Test the two boards for fit and flushness. If the joint is loose, turn the e7-Bush to a higher number, say “6” and rout two more board ends. If the joint is too tight, turn the e7-Bush to a lower number, say “4”. Trial and error establish the best e7-Bush setting and record this in the space provided here, and/or on the pull-out. Next time this setting will get a good first-time result

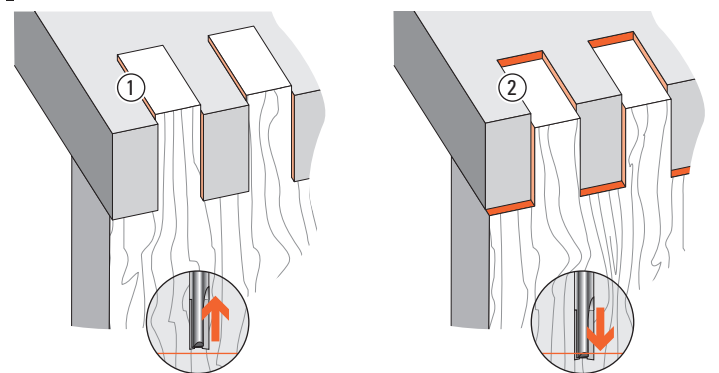

14-11 If the joint is over-flush ①, raise the bit slightly. If it is under-flush ②, lower the bit.

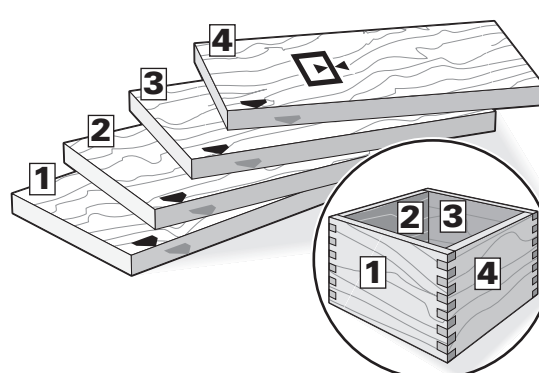

14-12 Let's make a box.

Prepare four boards and number them **1** to **4**. Then select the grain alignment and mark the common top (or bottom) edge. Don't worry about face side selection; this can be done after routing.

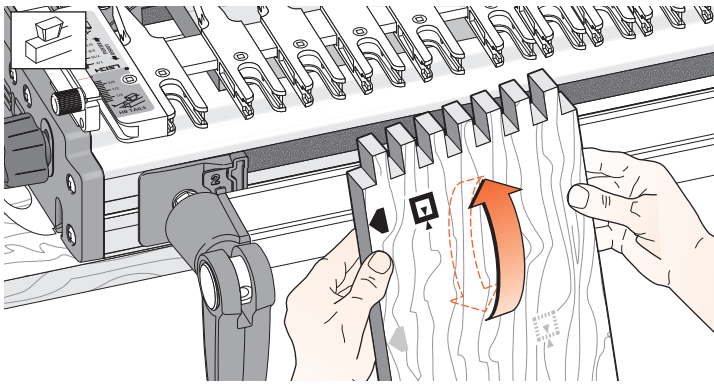

14-13 All box joint boards are clamped alternating face side in and face side out [icon] always with the same side edge against the side stop (or Spacer).

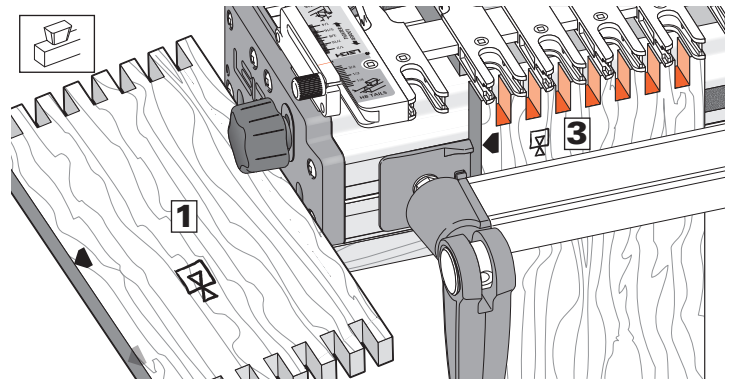

14-14 Rout both ends of boards **1** and **3** with their edges against the side stop. Be sure to keep the same edge to the stop.

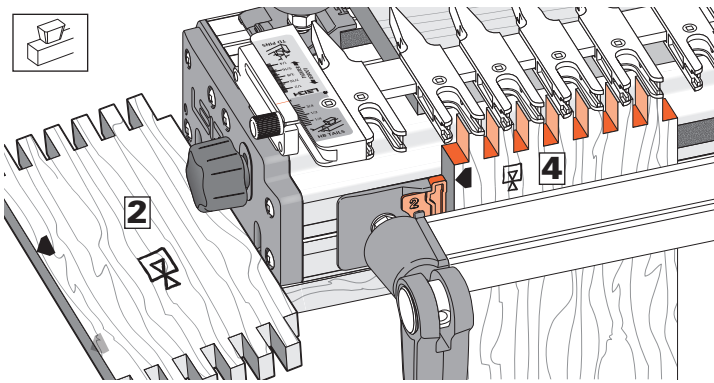

14-15 Rout both ends of boards **2** and **4** with their edges against the Spacer and the Spacer in the No.2 position. Keep the same edges to the Spacer.

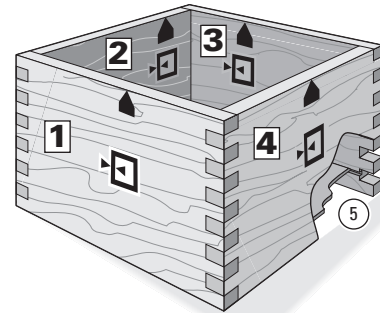

14-16 Keeping the marked side stop edges of all boards toward the top (or all to the bottom) of the box, select the preferred outside faces before routing the grooves ⑤ for the bottom.

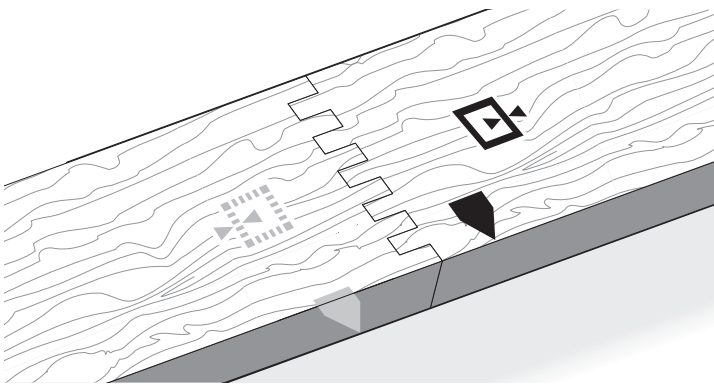

14-17 The same method will produce end-on-end joints.

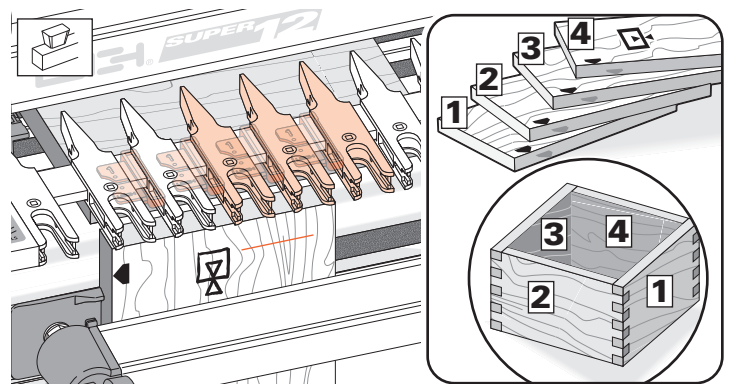

14-18 5/8" [16mm] Box Joints Set up and space the guide fingers exactly as for 5/16" [8mm] joints. Start with the same e7-Bush setting. See 14-4 thru 14-10.

Prepare four boards using the board width chart for 5/8" [16mm] joints and number them **1** to **4** around the box ① with the common edges marked.

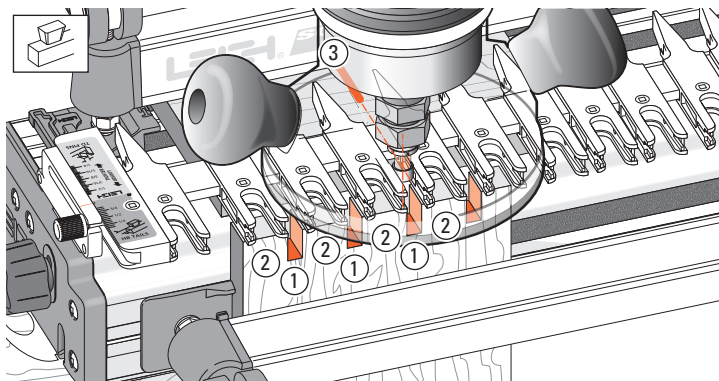

14-19 Rout both ends of boards 1 and 3 but **only rout between the guide finger sides ① not between the finger openings ②**. Keep the common edge against the side stop
Hint: Mark the router base at the 12 o'clock position ③ and steer this mark between the **pointed ends of the fingers** at the rear of the assembly.

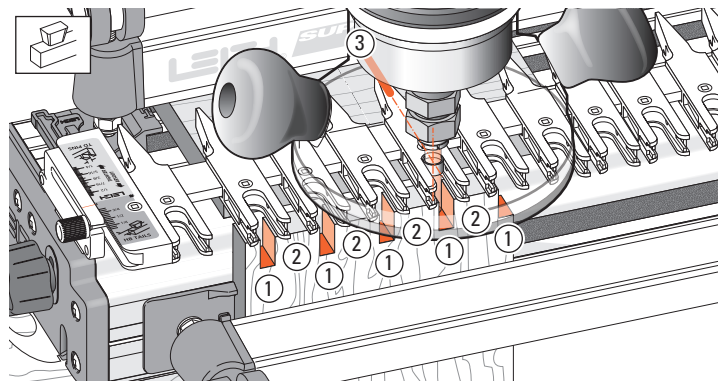

14-20 Now rout both ends of boards 2 and 4, with the common edge against the side stop but **only rout between the finger openings ① not between the finger sides ②**.
Hint: Now steer the base 12 o'clock mark **along the finger points ③**.

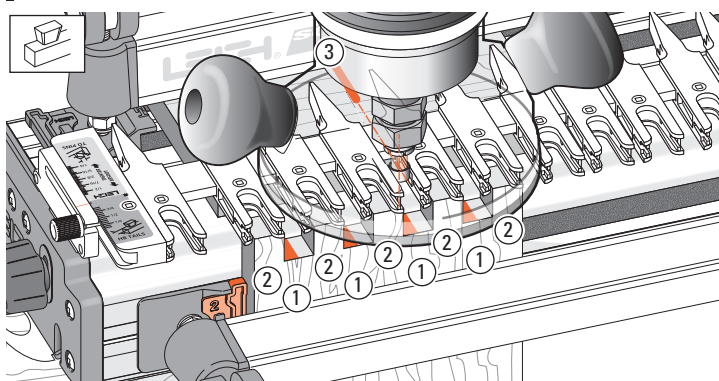

14-21 Fit the Spacer to the side stop with number 2 showing. Now rout both ends of boards 1 and 3 again, with the common edge against the Spacer and **again ... only rout between the guide finger sides ①, not between the finger openings ②**, steering the router mark between the finger points ③.

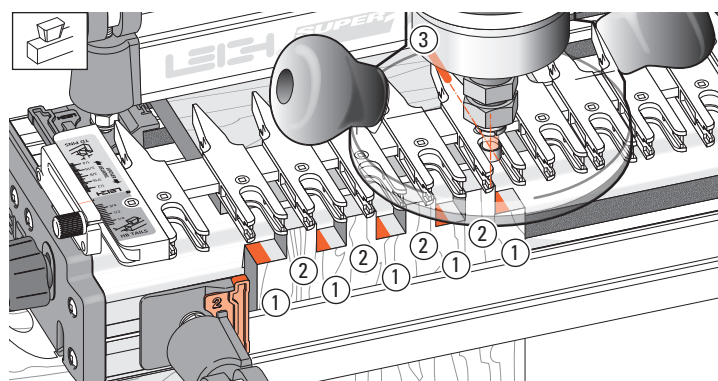

14-22 With the Spacer still in position rout both ends of boards 2 and 4, with the common edge against the Spacer and **again, only rout between the finger openings ①**, steering the router mark along the finger points ③.

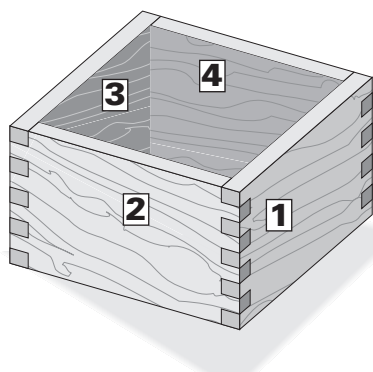

14-23 Joint fit Check for joint fit as usual, and repeat testing if required.

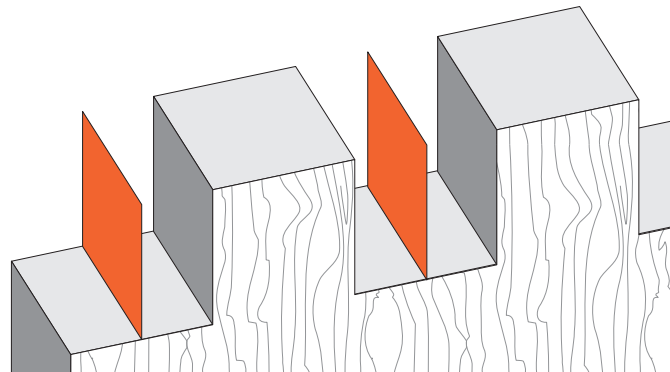

14-24 Theoretically, there will be nothing in the $\frac{5}{8}$ " [16mm] sockets, literally a zero thickness wall, where the bit has passed by twice. However, routing tolerances can leave a very thin "wall" uncleared by routing. This can be quickly removed with a chisel or sandpaper. ■

SUPERJIG - CHAPTER 15

Hints and Tips

Here are some special techniques and ideas to help you get the most out of your Leigh Superjig.

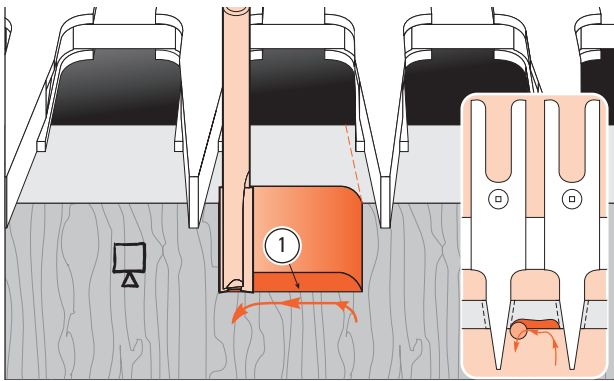

15-1 Through Dovetail Pins With the straight bit, carefully climb-rout from right to left. Make sure you control the router firmly when climb routing.

Climb routing produces a nice clean shoulder at ①.

Note: For clarity, the guidebush is not shown in this sequence.

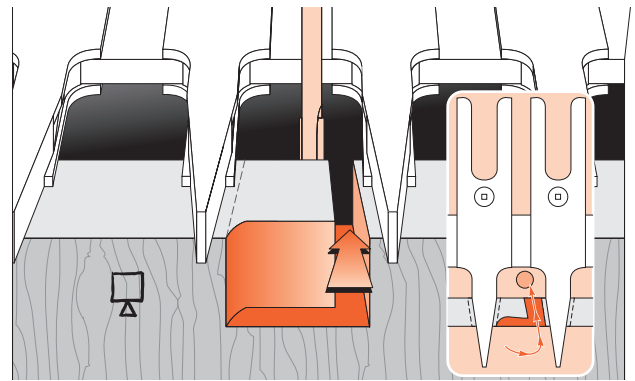

15-2 ⚠️ Rout through on the right side until the bit is clear of the workpiece. Move the bit to the left side and climb cut left to right.

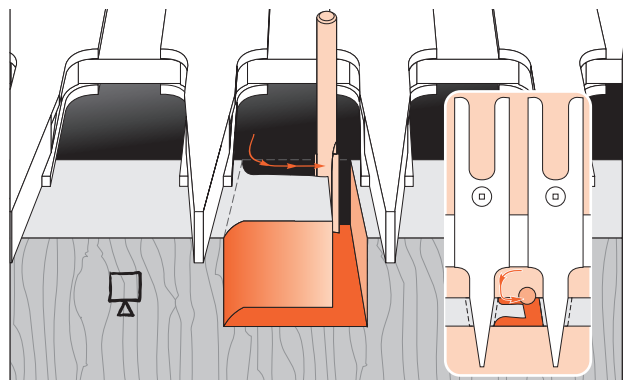

15-3 Climb rout from left to right from the rear of the cut. Take care to control router.

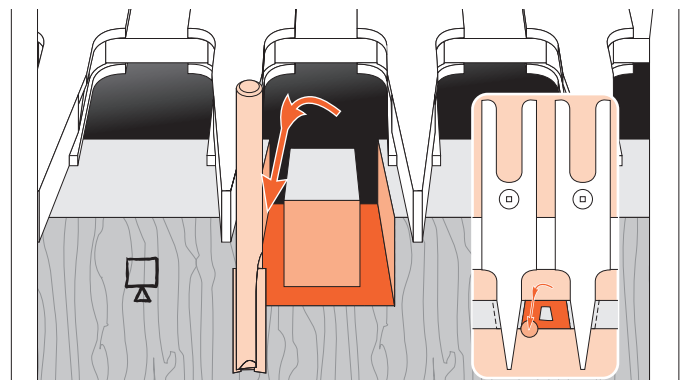

15-4 ⚠️ Rout back through towards you on the left side.

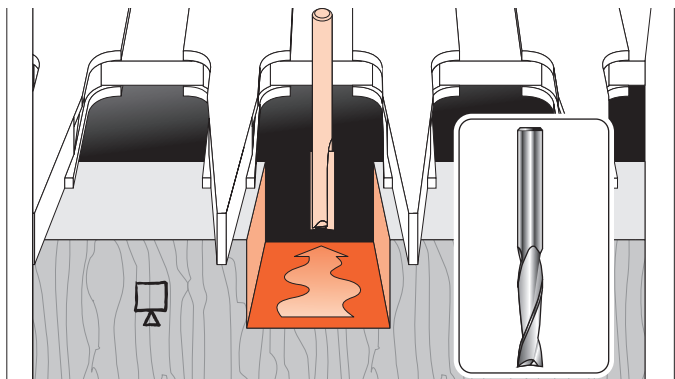

15-5 Rout away the rest of the waste. **Note:** Spiral up-cut straight bits (inset) generally rout more smoothly than the two-flute carbide-tipped bits. If you want to try them, you should be aware that while the high-speed steel bits take a better edge, they are much less durable than the more costly solid carbide type (Leigh bits 170 HSS or 170C solid carbide).

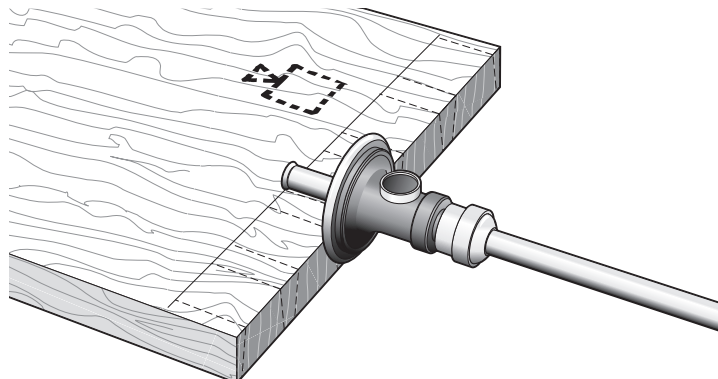

15-6 Preventing TD Pins Tearout To help prevent tearout at the back bottom part of a straight cut, scribe a line with your marking gauge across the back of the pin board at exactly the depth of cut.

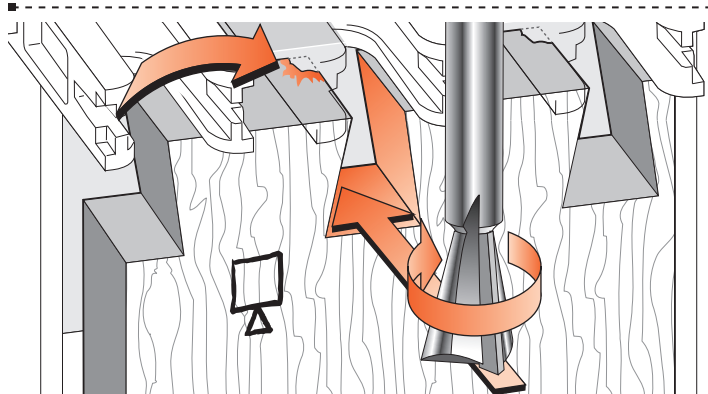

15-7 Dovetail Tails Tearout With the dovetail bit, most tearout occurs at the top left exit of the cut.

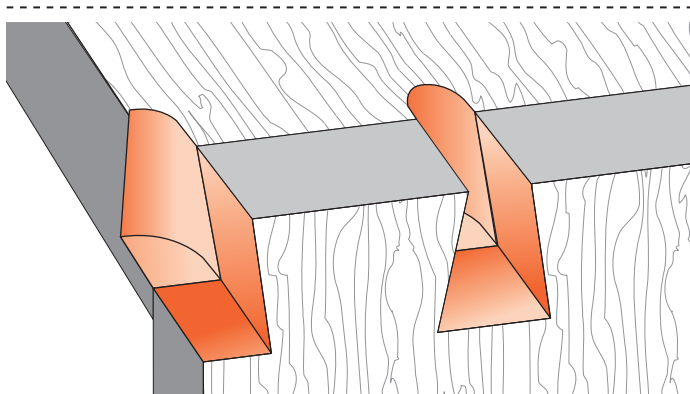

15-8 To help prevent this, back up the cut with the end-grain of a horizontal board pushed against the back of the workpiece and held in the rear clamp. This board replaces the spacer board.

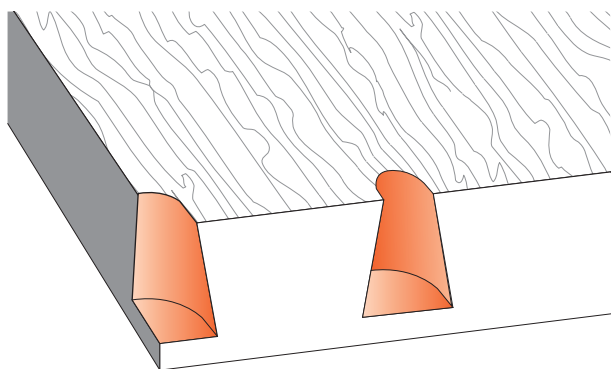

15-9 This same scrap piece can remain in place for successive cuts.

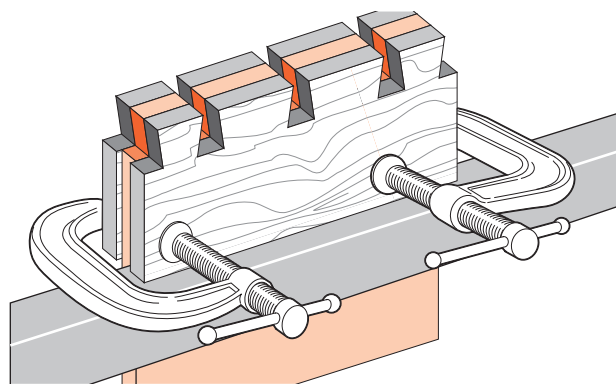

15-10 For vulnerable or that last piece of exotic wood, clamp horizontal scrap pieces to the front and back of the work piece. **Make sure clamps are below the bit depth.**

⚠️ **PLYWOOD** is not suitable for routing; the laminates are very prone to tearout. Either of these two procedures (15-10 or 15-11) are essential for plywood but provide no guarantee of success.

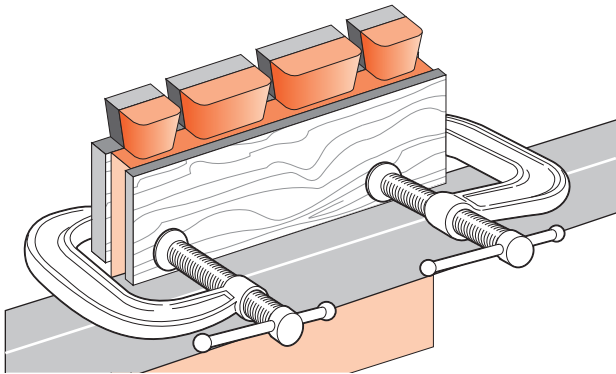

15-11 A single scrap piece can be C-clamped on the back of half-blind tails, *but make sure you protect the workpiece from the clamp pads.* Note: There's no 100% solution to tearout. It's not the jig's fault, just something that happens when machining, sawing and even chiseling wood. Important pieces fall off from where you least want them to.

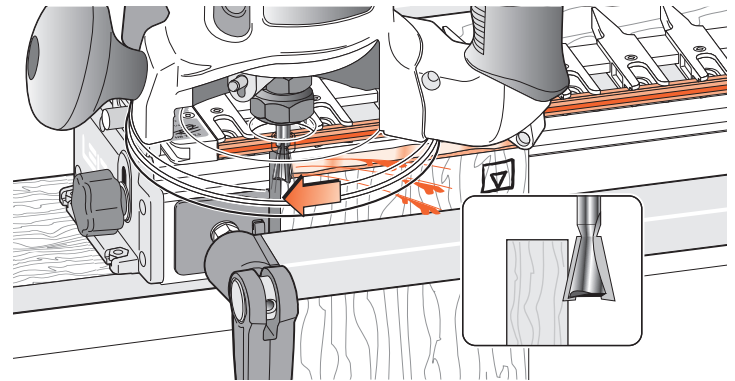

15-12 On face cuts, whether using a straight bit or a dovetail bit, climb routing or back routing will leave a clean edge; **but great caution must be exercised in controlling the router's movement from right to left, as the bit rotation pulls the router in that direction anyway.**

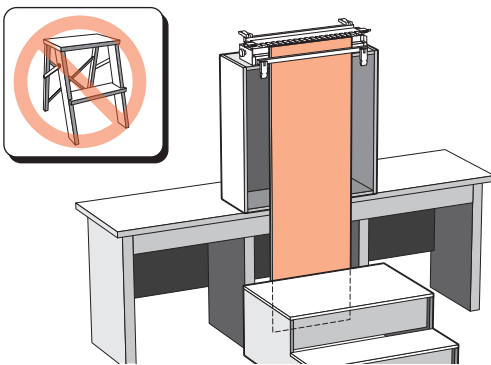

15-13 General Hints For routing long vertical boards it may be necessary to build a jig stand to mount securely on your bench. Make the stand and bench height combination sufficient to accept the board length you have in mind. The jig stand should be bolted securely to the bench. Build a stable platform to stand on as in the illustration. **Do not use a set of steps; they're too unstable.**

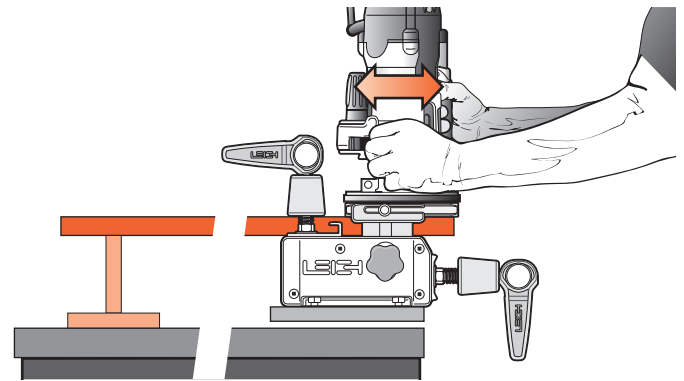

15-14 When placing long horizontal boards in the rear clamp, make sure the rear end of the board is supported to prevent unnecessary racking of the jig.

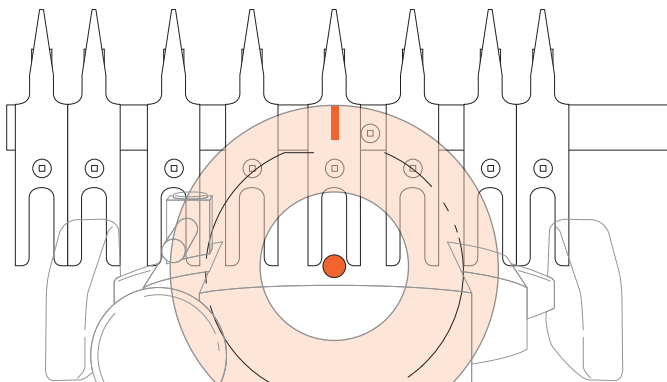

15-15 Using The Router Mark the router base top edge at the 12 o'clock position with a felt marker pen. Without wood or bits, try some **dry runs** in each jig mode. This will soon get you used to positioning the guidebush against the correct guide surface without looking under the router.

⚠ Do not rout at face level.

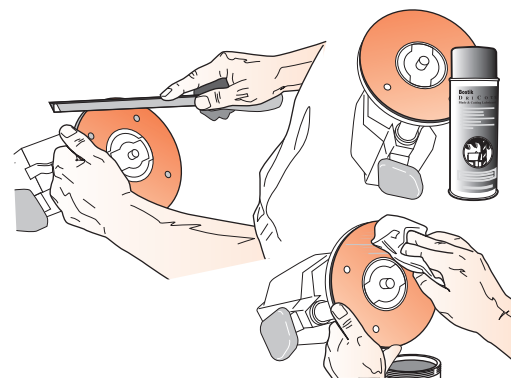

15-16 Some router bases have sharp edges on the outside and inside corners. A slight chamfer of the edges with a fine file or sandpaper block will ease router movement on the jig. An occasional light spray of TopCote® or application of soft wax to the router base makes for smooth, easy router movement on the jig. ■

Attaching the Leigh e-Bush to the Router

e-Bush and Guidebush Adaptors

The Leigh e-Bush fits directly to some popular routers such as Porter Cable, Black & Decker, and Dewalt. Many other makes, e.g. Bosch, Fein, Festool, Milwaukee etc., offer or come with base adaptors that accept the e-Bush. Leigh offers eight adaptors, plus the Bosch RA1100 and RA1126, allowing the use of over one hundred other router models, new and old. The 711C (7/16" OD) may be used in place of the e7 for dovetails, however it does not allow fit adjustment for box joints. See the next page for a list of routers.

e-Bush Adaptors

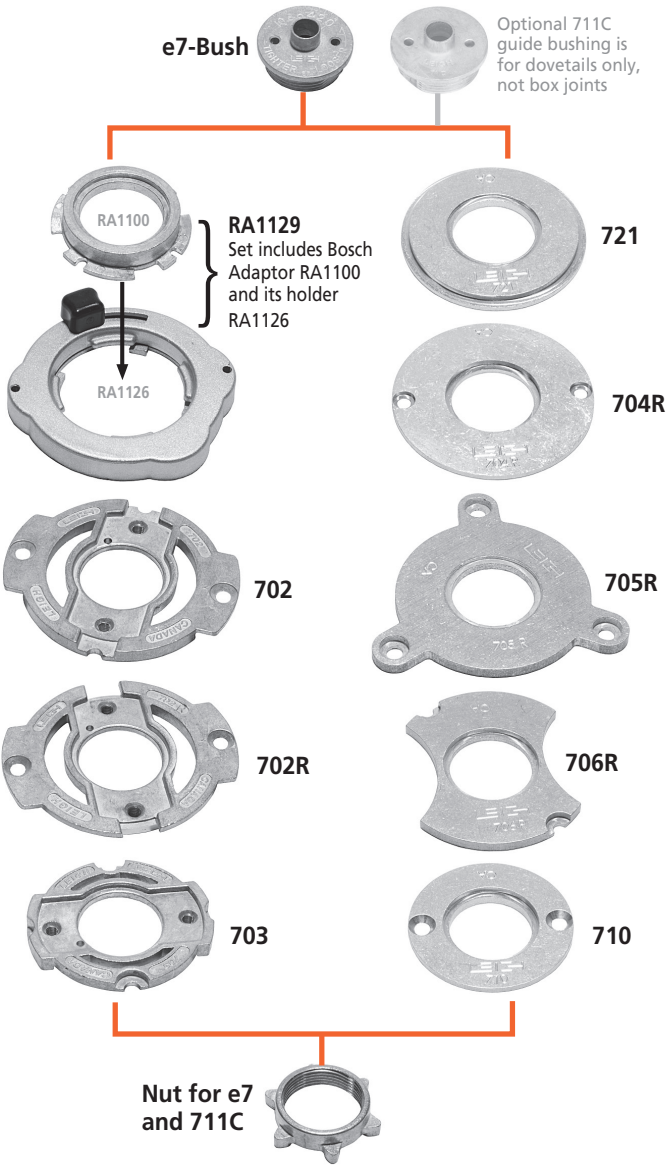

e-Bush Mounting Variations

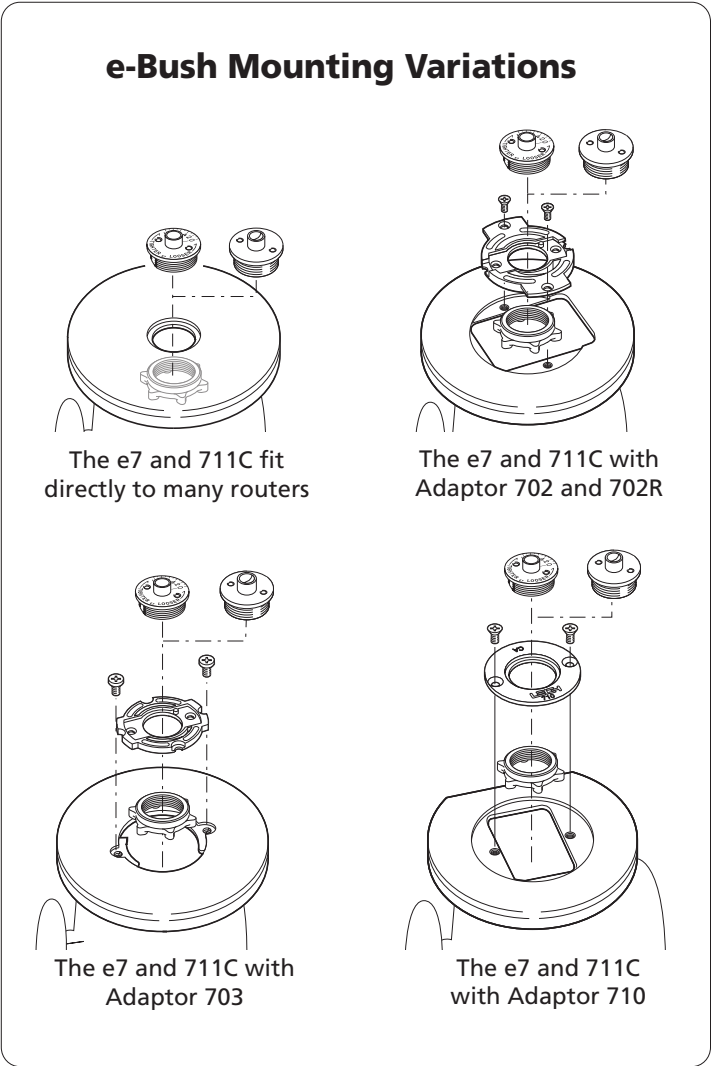

Template Guide Bushing and Adaptor Selection

Leigh dovetail jigs require a router fitted with a guide bushing. An adaptor may be required to fit the bushing to the router. *See www.leighjigs.com for the complete list of routers.*

DIRECTIONS

A. Locate name of router maker in Column 1.

B. Locate router model in Column 2. If your router is not listed visit leighjigs.com for a complete, up-to-date list of routers.

C. Locate adaptor required for your router in Column 3.

- Order Leigh adaptors (part no's in red) in Column 3 from Leigh.
- Order Bosch adaptors RA1100 and RA1126 in Column 3 from Leigh or your Bosch dealer.
- Order all other adaptors in Column 3 from the router manufacturer's dealer.

Note: Adaptor mounting screws are included with router.

■ MAFELL – Rework adaptor slightly.

D. Guide bushings in Column 4 fit all adaptors listed and may be ordered if required.

- ◆ The e7 elliptical guide bushing (7/16" [11,1mm]) is supplied with all Leigh SuperJigs for routing dovetails and box joints. Order only if you require a replacement. The 711C/711TP* guide bushing (7/16" [11,1mm]) can also be used, but only for routing dovetails.

All 8mm shank bits work with the e7-Bush supplied with your Leigh jig, or with any 7/16" OD [11,1mm] guide bushing that has a min. barrel length of 1/4" [6,35mm]. No other guide bushing sizes can be used.

***Note:** The 711C has replaced the 711TP guide bushing.

1 ROUTER MAKER	2 ROUTER MODEL	3 ROUTER ADAPTOR	4 7/16" OD BUSHING ◆	
AEG	OFE 710 in plunge base	Not Required	e7 or 711C	
	OFSE 2000	703	e7 or 711C	
	RT1350E	706R	e7 or 711C	
BLACK & DECKER	All Professional, HD1250, RP400K, 7614	Not Required	e7 or 711C	
	6200	720673-00	e7 or 711C	
	SR100, 7AEE, KW780 series, KW800, KW850	710	e7 or 711C	
BOSCH	90085, 90088, 90098, 90140, 90150, 90300, 90303, 90305, 91264	Aftermarket base plate required	e7 or 711C	
	1600, 1601, 1602, 1603, 1604, 1606, B1350	RA1110 required	e7 or 711C	
	North American ROUTERS PRODUCED AFTER mid-2010: 1613EVS, 1613AEVS, 1617, 1617EVS, 1618, 1618EVS, 1619EVS, MR23EVS, MRC23EVS, MRF23EVS, MRP23EVS	RA1100 & RA1126 required. Sold only as Set RA1129. (Set includes RA1100 and RA1126)		e7 or 711C
	North American ROUTERS PRODUCED BEFORE mid-2010 and others available worldwide that include the RA1126 adaptor: 1613(EVS)(AEVS), 1614(EVS), 1617EVS, 1618EVS, 1619EVS, B1450, GOF900(CE)(ACE), GOF1200, GOF1250(CE)(LCE), GOF1300(CE)(ACE), GOF1600CE, GOF2000CE, GMF1400, GMF1600CE, POF800ACE, POF1100AE, POF1200AE, POF1400ACE	RA1100 required. Sold only as Set RA1129. (Set includes RA1100 & RA1126)		e7 or 711C
	1611, 1611EVS, 1615, 1615EVS, B1550, GOF1600, GOF1700ACE	702		e7 or 711C
CRAFTSMAN (SEARS)	All non-plunge models	Aftermarket base plate required	e7 or 711C	
	135275070 Plunge	See Skil 1823 or 1835		
	Other plunge models	702	e7 or 711C	
	MD11 Plunge & Fixed Base. MD9.5 Fixed Base	Not Required	e7 or 711C	
DEWALT	DW610, DW616, DW618	Not Required	e7 or 711C	
	DW613, DW615(UK)	710	e7 or 711C	
	DW614, DW615, DW621, DW624, DW625, DW626	N. America Only, Supplied w/router	e7 or 711C	
	DW621K, DW622 and DW626 outside N. America	706R	e7 or 711C	
	DW625 Type 1,2,3,5 outside N. America	702	e7 or 711C	
	DW624 & DW625 Type 4 outside N.America, DW625EK	702R	e7 or 711C	
ELU	OF15, OF15E, OF97, OF97E	706R	e7 or 711C	
	MOF68, MOF69, MOF96, MOF96E	710	e7 or 711C	
	MOF131, MOF177 Type 1,2, & 3	702	e7 or 711C	
	MOF177 Type 4, MOF177EK	702R	e7 or 711C	
	2720, 2721, 3328	Not Required	e7 or 711C	
	3303, 3304	E09600 or 761 270-00	e7 or 711C	
	3337, 3338, 3339	702	e7 or 711C	
FEIN	RT1800	Supplied w/router	e7 or 711C	
FESTOOL	OF1E , OF2E, OF650, OF900E ,OF1000, OF1010E	704R	e7 or 711C	
	OF2000, OF2000E	705R	e7 or 711C	
	OF1400 and OF2200 North America Only	Supplied w/router	e7 or 711C	
	OF1400 Outside North America	493566	e7 or 711C	
	OF2200 Outside North America	494627 O-Ring may be required to keep bushing centered	e7 or 711C	
FREUD	FT1700(2), FT2000, FT2200, FT3000	721	e7 or 711C	
HITACHI	TR8, TR12, FM8, M8, M12 Series	325211 OR 703	e7 or 711C	
	M12VC, KM12SC, KM12VC	Not Required	e7 or 711C	
	M12SA2, M12V2	325224	e7 or 711C	
		702 ■	e7 or 711C	
MAFELL	LO65E	702	e7 or 711C	
MAKITA	M363, MRP090, RP1800(F), RP1801(F), RP2300(FC), RP2301(FC), 3612C Europe Qk Fit Base	721	e7 or 711C	
	3600, 3606, 3608, 3612, 3612B, 3612BR, 3612C N. America, 3620, 3621, RP0900, RP900K	703	e7 or 711C	
	3601B	321 493-1	e7 or 711C	
	RP0910, RP1110C	706R	e7 or 711C	
	RF1100, RF1101, RD1100, RD1101, RP1101	Not Required	e7 or 711C	
MASTERCRAFT	Please contact Leigh for assistance			
METABO	OF1612, OFE1812 (for all others, please contact Leigh for assistance)	704R	e7 or 711C	
MILWAUKEE	5615, 5616, 5619	49-54-1040 (replacement base)	e7 or 711C	
	5625	49-54-1026 (replacement base)	e7 or 711C	
	5670	Not Required	e7 or 711C	
PERLES	OF808 Series, OFE6990	710	e7 or 711C	
PORTER CABLE (ROCKWELL)	All	Not Required or Supplied w/router	e7 or 711C	
RIDGID	R2930 (for all others, please contact Leigh for assistance)	704R	e7 or 711C	
RYOBI	R30, R50, R150, R151, RE155, R500, R501, R502	703	e7 or 711C	
	R600, R601, RE600, RE601	702	e7 or 711C	
	R160, R161, R162, R163K, R165, R170, R175, RE175, R180, R180PL, R181, R185, ERT1150	706R	e7 or 711C	
	1823 or 1835	91803	e7 or 711C	
SKIL	SK1810, 1815, 1820, 1825	RAS140	e7 or 711C	
	All others	Aftermarket base plate required	e7 or 711C	
TREND	T3, T4, T5, T9, T10, T11—UniBase required	710	e7 or 711C	
TRITON	TRC001	TGA006 or 704R	e7 or 711C	
	JOF001, MOF001, TRA001	Accessory Kit (includes adaptor) TGA001 or TGA150	e7 or 711C	
WEGOMA	OF850 Series	710	e7 or 711C	

Bit Selection

Optional router bits for variably spaced through and half-blind dovetails.

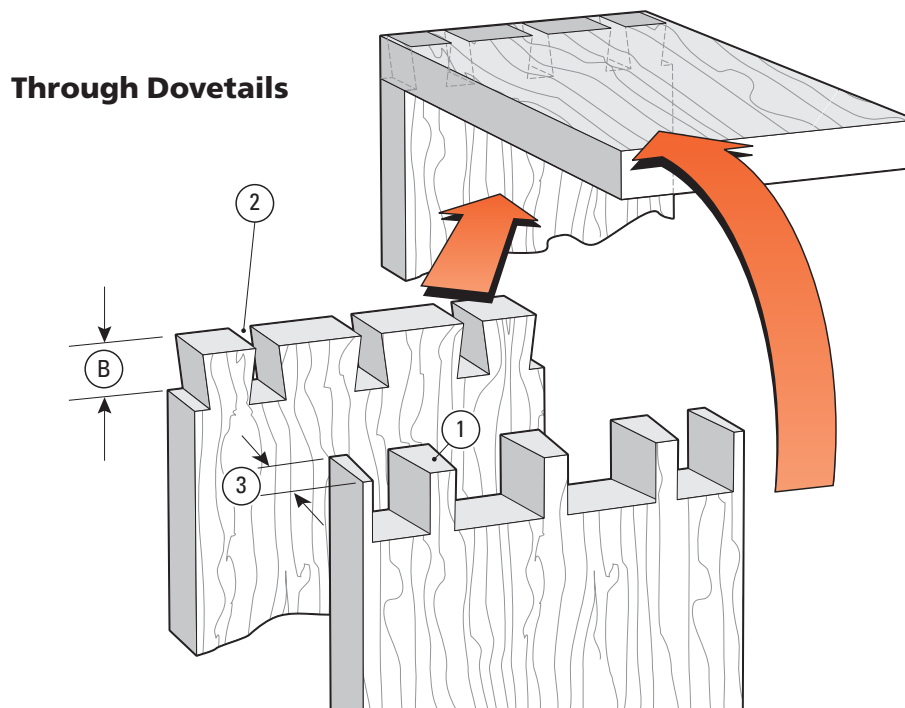

Bit Selection for Through Dovetails

8° Dovetail Bit for Tails

The pins ① must fit into the sockets ②. So the dovetail bit's depth of cut ③ must be equal to or a little greater than the pinboard thickness ③.

Measure the pinboard thickness ③ and select the dovetail bit with

the correct depth of cut ③ from the following pages (bits must be 8° for through dovetails).

Straight Bit for Pins

The matching straight bit is listed just below the dovetail bits. The $\frac{5}{16}$ " diameter No. 140-8, 8mm shank is the only straight bit you need with the Superjig.

Guidebush

All joints on the Superjig are routed with the e7-Bush, or all but box joints with any $\frac{7}{16}$ " OD guidebush (min. barrel depth $\frac{1}{4}$ "). See page 68.

Shank Selection

Note: You will require a router with an 8mm or $\frac{1}{2}$ " [12,7mm] collet to use our 8mm shank bits. For a $\frac{1}{2}$ " [12,7mm] collet router you will require our $\frac{1}{2}$ " [12,7mm] to 8mm collet reducer No. 172-8. Note: This is a collet reducer ④, not a collet ⑤. It does not replace the collet, it slides directly into your $\frac{1}{2}$ " collet. *Do not remove the collet nut when installing the collet reducer.*

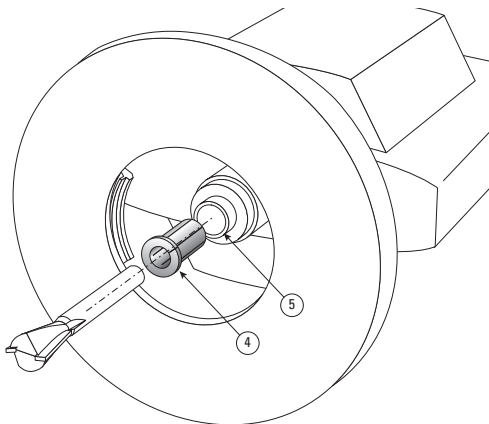

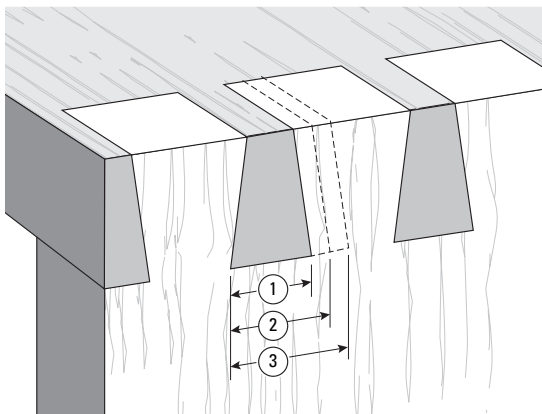

You will note that some of the dovetail bits' depths of cut overlap. For example:
 No.80-8 bit (B): 1/2" - 13/16" [12 - 20mm]
 No.70-8 bit (B): 1/4" - 1/2" [6 - 12mm]

This means that 1/2" boards can be joined using either the No.80-8 and 140-8 combination, the No. 75-8 and 140-8 combination, or the No.70-8 and 140-8 combination. The three bit combinations will produce slightly different-looking joints because each dovetail bit produces a different size pin:
 No. 70-8 3/8" ①
 No. 75-8 7/16" ②
 No. 80-8 1/2" ③.

⚠ Do not attempt to rout dovetails at less than the minimum depth of cut specified.

Note: Bit and joint drawings are about actual size.

Leigh Through Dovetail Bits

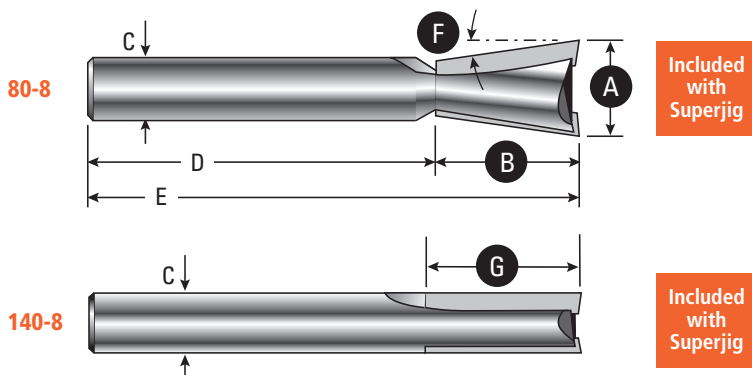
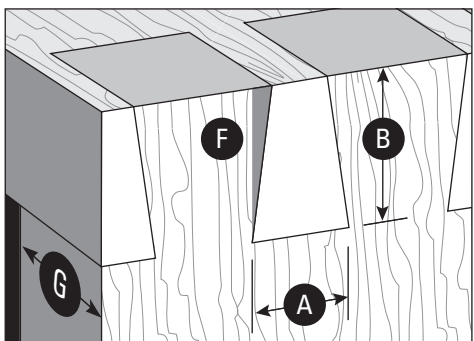

Bits	A Overall Diameter	B/G Cutting Depth Range	C Shank Diameters	D Shank Length	E Overall Length	F Angle	Guidebush Diameter
No. 80-8*	1/2" [12,7]	B 1/2" to 13/16" [13,0-20,6]**	8mm	1-3/4" [45,0]	2-9/16" [65,0]	8°	e7 or 711C 7/16" [11,1]
No. 140-8*	5/16" [7,9]	G up to 1" [26,0]	8mm	1-3/4" [45,0]	2-3/4" [70,0]	-	e7 or 711C 7/16" [11,1]

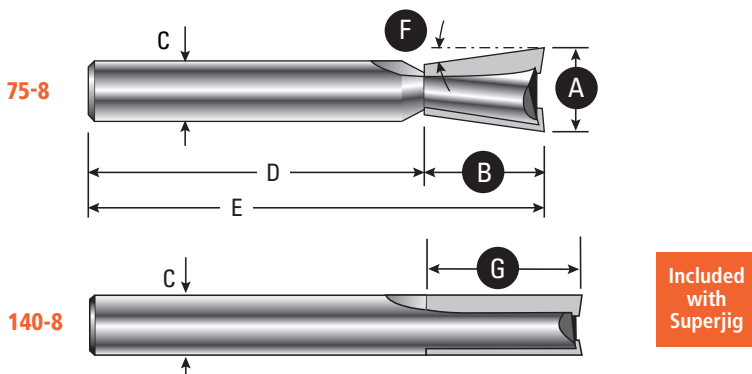
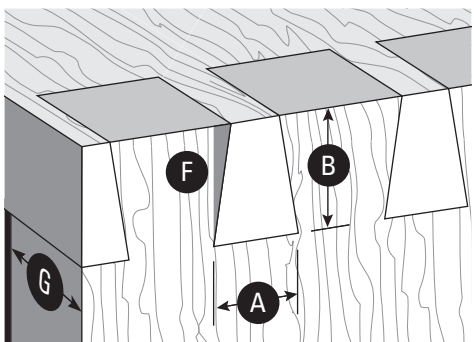

Bits	A Overall Diameter	B/G Cutting Depth Range	C Shank Diameters	D Shank Length	E Overall Length	F Angle	Guidebush Diameter
No. 75-8	7/16" [11,1]	B 3/8" to 5/8" [9,5-16,0]	8mm	1-3/4" [45,0]	2-3/8" [60,0]	8°	e7 or 711C 7/16" [11,1]
No. 140-8*	5/16" [7,9]	G up to 1" [26,0]	8mm	1-3/4" [45,0]	2-3/4" [70,0]	-	e7 or 711C 7/16" [11,1]

Numbers in brackets are millimeters

* Bits 80-8, 120-8, and 140-8 come standard with Leigh Super Jigs

**Maximum pin board thickness = 13/16"

Note: Bit and joint drawings are about actual size.

Leigh Through Dovetail Bits

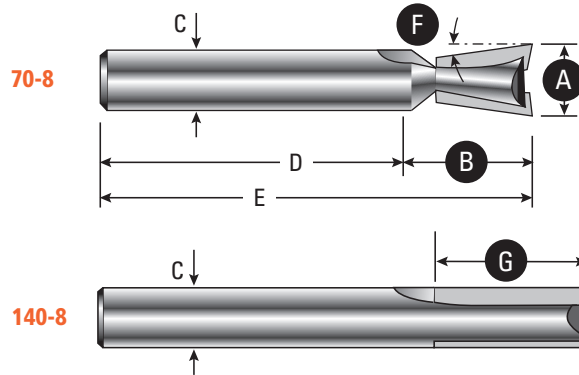
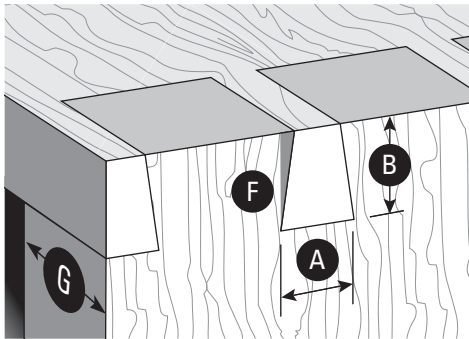

Included with Superjig

Bits	A Overall Diameter	B/G Cutting Depth Range	C Shank Diameters	D Shank Length	E Overall Length	F Angle	Guidebush Diameter
No. 70-8	3/8" [9,5]	B 1/4" to 1/2" [6,0-13,0]	8mm	1-3/4" [45,0]	2-1/4" [57,0]	8°	e7 or 711C 7/16" [11,1]
No. 140-8*	5/16" [7,9]	G up to 1" [26,0]	8mm	1-3/4" [45,0]	2-3/4" [70,0]	-	e7 or 711C 7/16" [11,1]

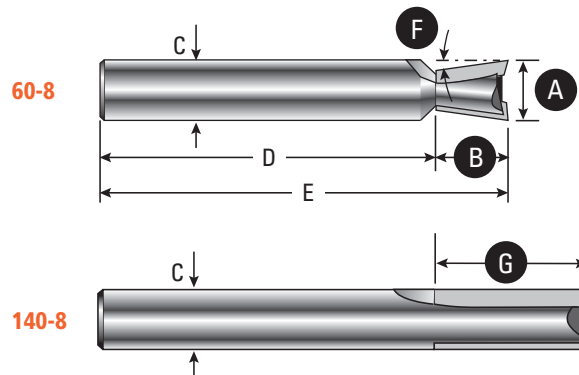
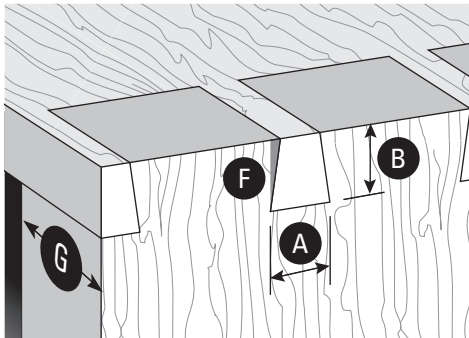

Included with Superjig

Bits	A Overall Diameter	B/G Cutting Depth Range	C Shank Diameters	D Shank Length	E Overall Length	F Angle	Guidebush Diameter
No. 60-8	5/16" [7,9]	B up to 3/8" [9,5]	8mm	1-3/4" [45,0]	2-1/8" [54,0]	8°	e7 or 711C 7/16" [11,1]
No. 140-8*	5/16" [7,9]	G up to 1" [26,0]	8mm	1-3/4" [45,0]	2-3/4" [70,0]	-	e7 or 711C 7/16" [11,1]

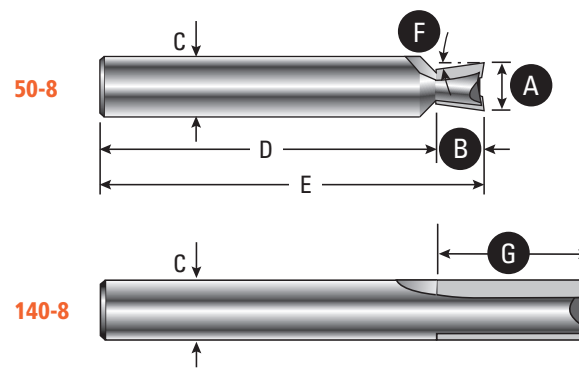
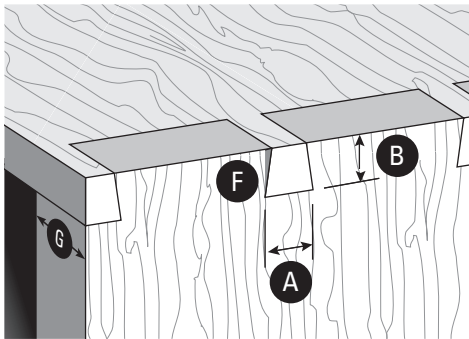

Included with Superjig

Bits	A Overall Diameter	B/G Cutting Depth Range	C Shank Diameters	D Shank Length	E Overall Length	F Angle	Guidebush Diameter
No. 50-8	1/4" [6,35]	B up to 1/4" [6,35]	8mm	1-3/4" [45,0]	2" [50,0]	8°	e7 or 711C 7/16" [11,1]
No. 140-8*	5/16" [7,9]	G up to 1" [26,0]	8mm	1-3/4" [45,0]	2-3/4" [70,0]	-	e7 or 711C 7/16" [11,1]

Numbers in brackets are millimeters

* Bits 80-8, 120-8, and 140-8 come standard with Leigh Super Jigs

Half-Blind Dovetails

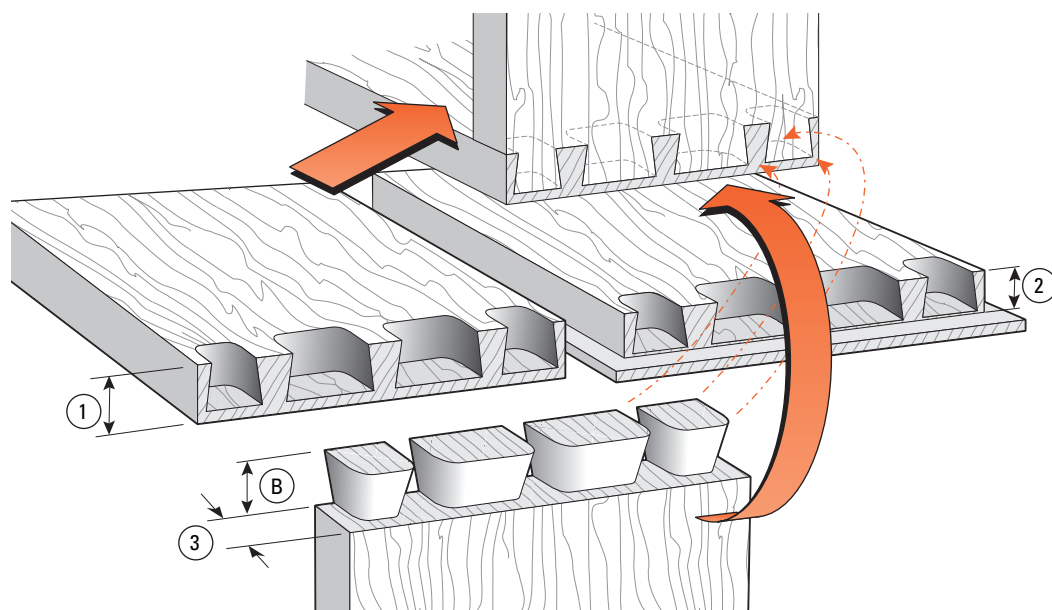

Bit Selection for Half-Blind Dovetails

Both parts of a half-blind dovetail are cut with the same dovetail bit. The dovetail bit's working depth of cut (B) must be less than the pinboard thickness (1) for flush drawers by at least $\frac{1}{8}$ " [2mm], and slightly less than the rabbet depth (2) for rabbeted drawer fronts. Minimum pin board (drawer front) thickness is $\frac{1}{2}$ " [12mm].

Drawer side thickness (3) does not affect bit selection.

Note: (B) is the nominal working depth for half-blind

dovetails, not the maximum depth. (B) must not be varied, except for minor adjustments for joint fit. *See page 35.*

Measure the drawer front thickness (minimum $\frac{1}{2}$ " [12mm]) (1) or rabbet depth (minimum $\frac{7}{16}$ " [11,1mm]) (2) and select the bit with the appropriate depth of cut (B) from one of the five bits on the following pages.

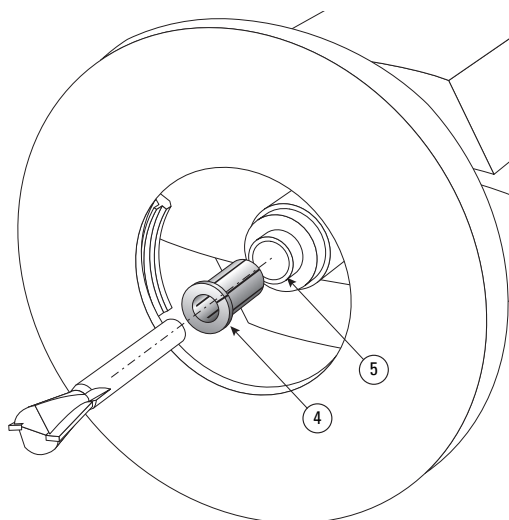

Guidebush

All joints on the Superjig are routed with the e7-Bush, or all but box joints with any $\frac{7}{16}$ " OD guidebush (min. barrel depth $\frac{1}{4}$ "). *See page 68.*

Shank Selection

Note: You will require a router with an 8mm or $\frac{1}{2}$ " [12,7mm] collet to use our 8mm shank bits.

For a $\frac{1}{2}$ " [12,7mm] collet you will require our $\frac{1}{2}$ " [12,7mm] to 8mm collet reducer No.172-8.

Note: This is a collet reducer (4), not a collet (5). It does not replace the collet, it slides directly into your $\frac{1}{2}$ " collet. *Do not remove the collet nut when installing the collet reducer.*

Note: Bit and joint drawings are about actual size.

Leigh Half-Blind Dovetail Bits

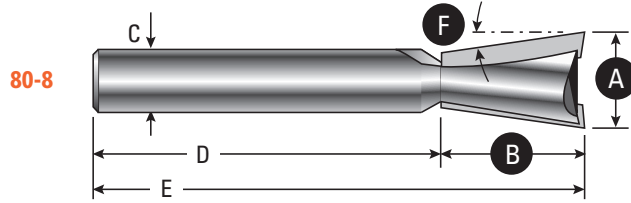
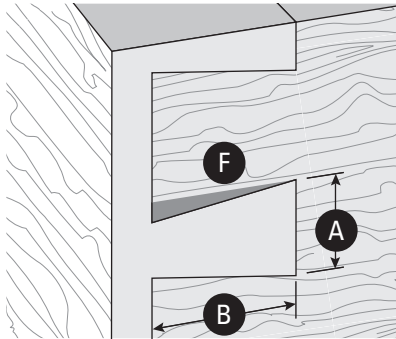

Included with Superjig

Bits	A	B		C	D	E	F	Guidebush Diameter
	Overall Diameter	Working Depth						
		HB Variable	HB 1-Pass					
No. 80-8*	1/2" [12,7]	~3/4" [19]	~1/2" [12,7]	8mm	1-3/4" [45,0]	2-9/16" [65,0]	8°	e7 or 711C 7/16" [11,1]

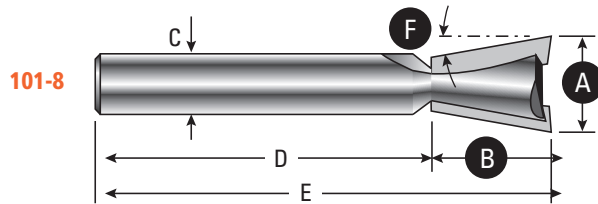
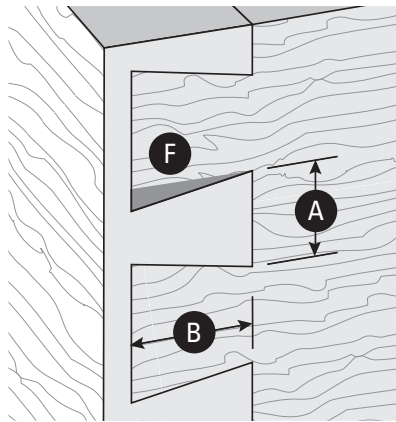

Bits	A	B		C	D	E	F	Guidebush Diameter
	Overall Diameter	Working Depth						
		HB Variable	HB 1-Pass					
No. 101-8	1/2" [12,7]	~5/8" [16,0]	~7/16" [11,1]	8mm	1-3/4" [45,0]	2-3/8" [60,0]	10°	e7 or 711C 7/16" [11,1]

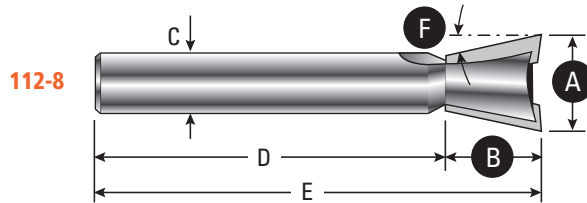
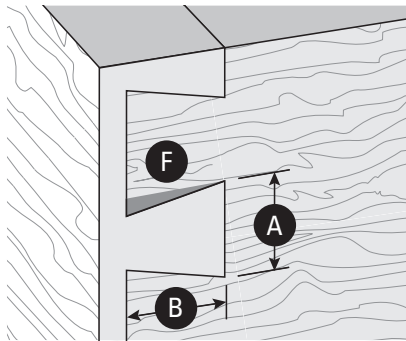

Bits	A	B		C	D	E	F	Guidebush Diameter
	Overall Diameter	Working Depth						
		HB Variable	HB 1-Pass					
No. 112-8	1/2" [12,7]	~1/2" [13,0]	~3/8" [9,5]	8mm	1-3/4" [44,0]	2-21/64" [59]	12°	e7 or 711C 7/16" [11,1]

Numbers in brackets are millimeters

* Bits 80-8, 120-8, and 140-8 come standard with Leigh Super Jigs

Note: Bit and joint drawings are about actual size.

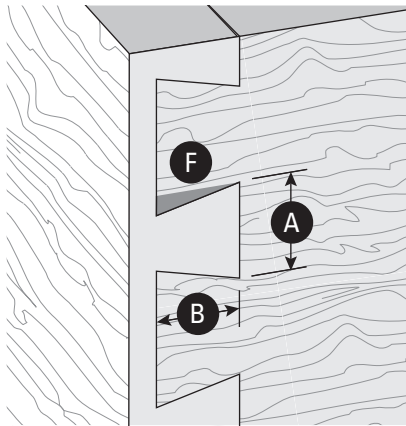

120-8

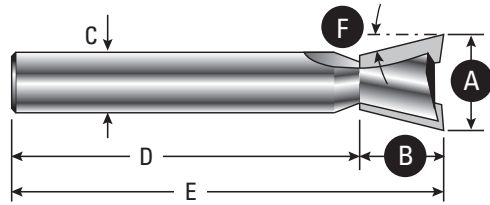

Included with Superjig

Bits	A	B		C	D	E	F	Guidebush Diameter
	Overall Diameter	Working Depth		Shank Diameters	Shank Length	Overall Length	Angle	
		HB Variable	HB 1-Pass					
No. 120-8*	1/2" [12,7]	~7/16" [11,0]	~9/32"[7,1mm]	8mm	1-3/4" [45,0]	2-1/4" [57]	14°	e7 or 711C 7/16" [11,1]

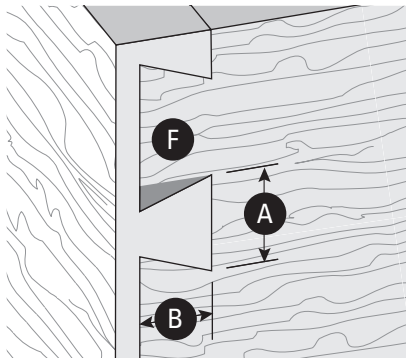

128-8

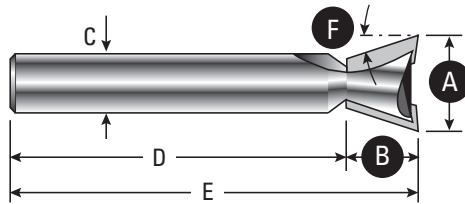

Bits	A	B		C	D	E	F	Guidebush Diameter
	Overall Diameter	Working Depth		Shank Diameters	Shank Length	Overall Length	Angle	
		HB Variable	HB 1-Pass					
No. 128-8	1/2" [12,7]	~3/8" [9,5]	7/32"[5,5]	8mm	1-3/4" [45,0]	2-1/8" [54,0]	18°	e7 or 711C 7/16" [11,1]

Numbers in brackets are millimeters

* Bits 80-8, 120-8, and 140-8 come standard with Leigh Super Jigs

SUPERJIG - Appendix III**Jig Parts**

See parts list and drawing on the following pages.

When ordering parts, please quote the jig model, serial number, part number, part description and quantity required. Pay particular attention to the scale measurement, and let us know if yours is inch or metric.

How to Order Parts

Order directly from Leigh by calling toll free 800-663-8932, or if you're outside North America contact your national distributor. Have your jig information ready — You'll need the jig model, serial number, part number, part description and quantity required. **Note:** Place the finger assembly in half-blind mode to determine left hand and right hand scales.

PART DESCRIPTION	QUANTITY	PART NO.	SUPER 12	SUPER 18	SUPER 24
Super Jig Front Body Extrusion	1		8012	8018	8024
Super Jig Rear Body Extrusion	1		8112	8118	8124
Guide Fingers	see model	7200	Quantity 13	Quantity 16	Quantity 19
Guide Finger Nuts (Threaded)	see model	7210	Quantity 15	Quantity 18	Quantity 21
Guide Finger Washers	see model	7215	Quantity 15	Quantity 18	Quantity 21
Guide Finger Wedges	see model	7220	Quantity 15	Quantity 18	Quantity 21
8/32 x 6.57mm Finger Screws	see model	7225R	Quantity 15	Quantity 18	Quantity 21
R.H. Inch Scale Assembly, complete (R.H. in H.B. Tail Mode)	1	7230			
or R.H. Metric Scale Assembly, complete (R.H. in H.B. Tail Mode)	1	7230M			
L.H. Inch Scale Assembly, complete (L.H. in H.B. Tail Mode)	1	7235			
or L.H. Metric Scale Assembly, complete (L.H. in H.B. Tail Mode)	1	7235M			
SJ End Housing R.H.	1	8005			
SJ End Housing L.H.	1	8010			
SJ Support Bracket R.H.	1	8050			
SJ Support Bracket L.H.	1	8060			
Scale Block R.H. (RH in HB Tail Mode)	1	7230			
Scale Block L.H. (LH in HB Tail Mode)	1	7235			
SJ Non-Slip Self Adhesive Strips	4		8712	8718	8724
SJ Front Side Stops	2	8160			
SJ Rear Side Stops	2	8170			
SJ Spacer	1	8180			
Clamp Tube Extrusion - Front	1		8212	8218	8224
Clamp Tube Extrusion - Rear	1		8312	8318	8324
Clamp Tube End Plugs	4	7115			
Screwdriver - No. 2 Robertson Square Drive	1	550			
1" Aluminum Finger Bar	1		8412	8418	8424
Plastic Bridge Extrusions	3		8512	8518	8524
Nylon Depth Rod	1		8612	8618	8624
Support Bracket Knobs	2	7025			
Clamp Bar Springs	4	311			
Scale Thumb Screws	2	7250			
Scale Thumb Screw Washers	2	7255			
Clamp Bar T-Bolts - 5/16"-18 x 4"	4	7100			
8 x 1-1/2" End Housing Screws	12	7145			
5/16"-18 Hex Nuts	4	300			
5/16" SAE Flat Washers	4	283			
SJ Hold Down Screws #10 x 1"	4	8145			
SJ User Guide	1	8200			
SJ Instructional Pull Out	1	8210			
Cam Clamps	4	7125			
Cam Nuts 5/16"-18	4	7120			
SJ Instructional DVD	1	8250			
# 80-8 1/2" Dovetail Bit	1	80-8			
# 140-8 5/16" Straight Bit	1	140-8			
# 120-8 14° Dovetail Bit	1	120-8			
1/2" to 8mm Collet Reducer	1	172-8			
e7 eBush (guide Bushing) and nut	1	e7-Bush			
Pin Wrench	1	730V			

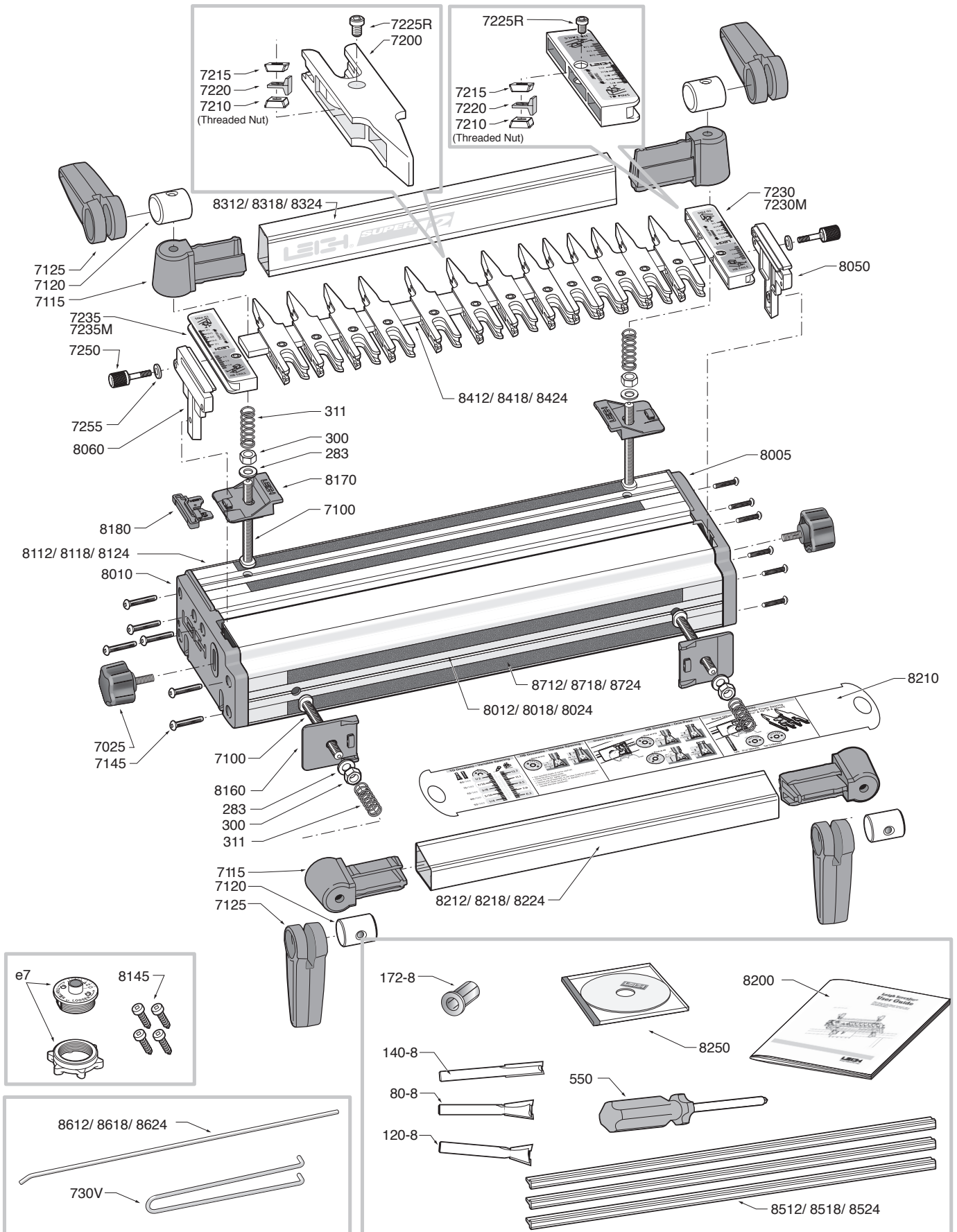

NOTE: When ordering parts, please quote the jig model, serial number, part number, part description and quantity required. Pay particular attention to the scale measurement, inch or metric.

SUPERJIG - Appendix IV

Customer Support

Our Commitment to You Leigh Industries takes pride in its commitment to providing excellence in customer service and support. This user guide is designed to provide you with the answers to any questions you have. However, if you require assistance, please feel free to contact our technical support staff or a distributor listed below.

Manufacturer: Canada/USA

TEL/FAX

Customer Service and Technical Support
800-663-8932 (Canada/USA)
604-464-2700 (Tel.)
604 464-7404 (Fax.)

EMAIL/WEB

Customer Service
leigh@leighjigs.com
Technical Support
help@leighjigs.com
Website
www.leighjigs.com

NOTE: Email can be useful, but technical queries usually raise queries from us. A phone call is the quickest and most convenient way to get queries answered, either directly to Leigh (toll free in N. America) or to your national distributor. –*Thanks!*

MAILING ADDRESS

Leigh Industries Ltd.
P.O. Box 357
Port Coquitlam, B.C.
Canada V3C 4K6

LOCATION

Leigh Industries Ltd.
1615 Industrial Ave.
Port Coquitlam, B.C.
Canada V3C 6M9

Distributors

AUSTRALIA & NEW ZEALAND

Maxis Distribution
128 Ingleston Rd., Wakerley, Qld., 4154
Australia
Tel: 1300 767 366
Tel (Int.) +61 7 3292 0392
Email: info@maxis.com.au
Web: www.maxis.com.au

CHINA

Harvey Industries Co., Ltd.
68-10 Suyuan Avenue
Jiangning District Nanjing 211100, China
Tel: (0)86 5792 8869 / 5792 8021
Fax: (0)86 5792 8826
Email: caozhi@harvey.cn
Website: www.harveyworks.cn

FRANCE

Ets Bordet
98 Rue Louis Ampère, 93330
Neuilly Sur Marne, France
Tel: 01 48 58 28 39
Fax: 01 48 58 48 58
Email: info@bordet.fr
Web: www.bordet.fr

GERMANY, AUSTRIA & SWITZERLAND

Hacker GmbH
Holzbearbeitungsmaschinen
Traberhofstraße 103 D-83026 Rosenheim
Deutschland
Tel: 08031 269650
Fax: 08031 68221
Email: hacker.rosenheim@t-online.de
Web: www.leigh.de

ITALY

Ferrari Macchine Legno SRL
Via Gallarata 74/76/78
20019 Settimo M.se (MI) Italy
Tel: 39 02 335 010 95
Fax: 39 02 335 005 27
Email: info@ferrariamacchine.com
Web: www.ferrariamacchine.com

JAPAN

Off Corporation Inc.
323-1 Yanbara, Shimizu-ku, Shizuoka-shi
Shizuoka-ken, Japan 424-0002
Tel: 81-50-3816-0115
Fax: 81-54-367-6515
Email: info@off.co.jp
Web: www.off.co.jp

KOREA

Leigh Korea
665-3, Munhyung-Ri, Opo-Eup, Kwangju-Si,
12774, South Korea
Tel: 82 (0) 70-8252-0988
Fax: 82 (0) 31-765-5602
Email: maengha@leigh.co.kr
Web: www.leigh.co.kr

NETHERLANDS, BELGIUM & LUXEMBOURG

Houtbewerking Krielaart
9217RR Nijega, Netherlands
Tel: +31 512 354 770
Email: gerard@gkrielaart.nl
Web: www.leighjigs.nl

RUSSIA

Unicom Ltd.
Nikitskij Boulevard 12
Moscow, 119019, Russia
Tel: 7 (495) 690 0454
Email: info@leighjigs.ru
Web: www.leighjigs.ru

SOUTH AFRICA

Hardware Centre
PO Box 4059, Randburg 2125
South Africa
Tel: +27 011 791-0844/46
Fax: +27 011 791-0850
Email: info@hardwarecentre.co.za
Web: www.hardwarecentre.co.za

SWEDEN

Toolbox Sweden AB
Bruksgatan 3, S-597 30
Atvidaberg, Sweden
Tel: 46 120 854 50
Fax: 46 120 854 69
Email: info@toolbox.se
Web: www.toolbox.se

UNITED KINGDOM & IRELAND

Axminster Tools & Machinery
Headquarters, Unit 10, Weycroft Avenue
Axminster, Devon
EX13 5PH United Kingdom
Tel: 0800 371822
Text: 07786 200699
Email: cs@axminster.co.uk
Web: www.axminster.co.uk/leigh



Printed in Canada