

Leigh Box Joint & Beehive Jig

Model B975

User Guide

For WorkBench or Router Table Use

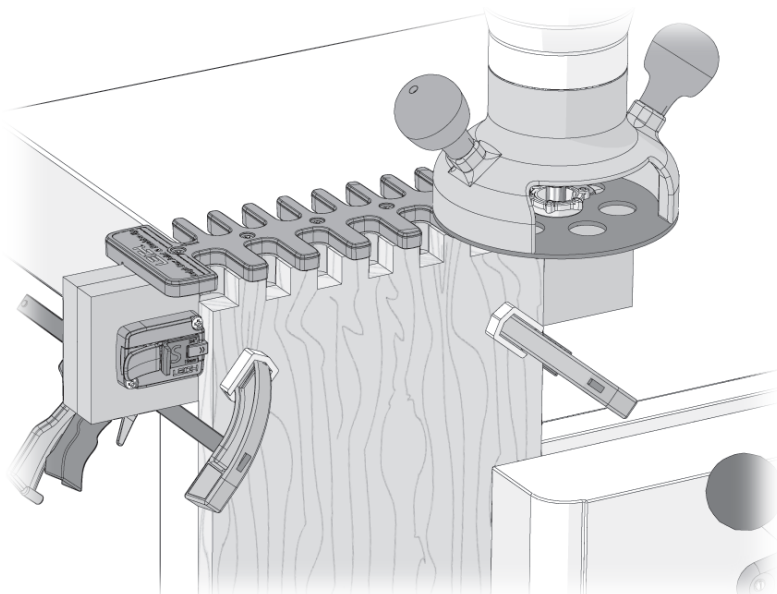

Workbench

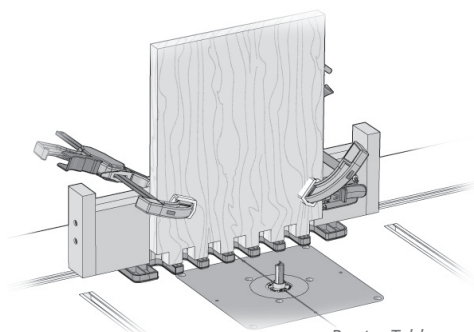

Router Table

See Page 65 for Customer Support
1-800-663-8932

LEIGH
Leigh Router Joinery Jigs

Contents

Chapter 1	Introduction	5
	Jig Parts	5
	Bit Specifications	7
	Symbols for Board Position	8
	Clamping	8
Chapter 2	Safety	9
Chapter 3	The Leigh e10 eBush	11
Chapter 4	Mounting & Assembly	15
Chapter 5	Routing Box Joints	25
Chapter 6	Routing Wider Boards	37
Chapter 7	Router Table Operation	47
Chapter 8	Guide Bushing Adapter Selection	63
Chapter 9	Customer Support	65

Your New Leigh Box Joint & Beehive Jig, Model B975

The Leigh Box Joint & Beehive Jig, Model B975, is a simple, easy-to-use tool for making 1/2" and 3/4" box joints on boards up to 13/16" [20.6mm] thick, and from 1-1/2" [38mm] to 17-13/16" [453mm] wide. Not by accident, the full 9-11/16" [246mm] width of the jig is the standard height of a typical beehive super, used in North America.

Customer Support

If you have any questions that are not answered in this user guide, please call Leigh Customer Support: 1-800-663-8932 in North America or email: help@leighjigs.com. For support contacts in your country of purchase, see Customer Support at the end of this Guide. Leigh user guides are updated as required. A downloadable pdf of the latest version can be found on the Support page at leighjigs.com.

Reminder: If at first you don't succeed, read the instructions!



5 Year Warranty

Leigh stands behind its products with a 5 year limited warranty. See the complete warranty in Chapter 9, Customer Support.

Register your Leigh B975

Here's Why!

- Be the first to learn new ways to use your jig
- Learn about updates to your jig
- Save \$\$ with Special Offers
- Find out about new product launches

**Register Now for Your Chance to
Win \$300 of Leigh Products***



Go to leighjigs.com
Click on Customer Service
Click on Registration

Privacy Policy Leigh will NEVER rent, sell or distribute your information.



*You must be at least 21 years of age to enter. Employees of Leigh Industries Ltd. and their families are ineligible to enter or win. This offer void where prohibited by law. Customer must complete a short online questionnaire. One winner will be drawn every two months. Winners will be notified by email and by phone. Leigh product is only available directly from Leigh or its international distributor in the region of the winner. No cash value. Value is in the currency of the country of winner equal to \$300.00 USD based on currency exchange at the time of the draw. Complete details available at www.leighjigs.com.

This page is left blank intentionally.

B975 User Guide

CHAPTER 1 Introduction

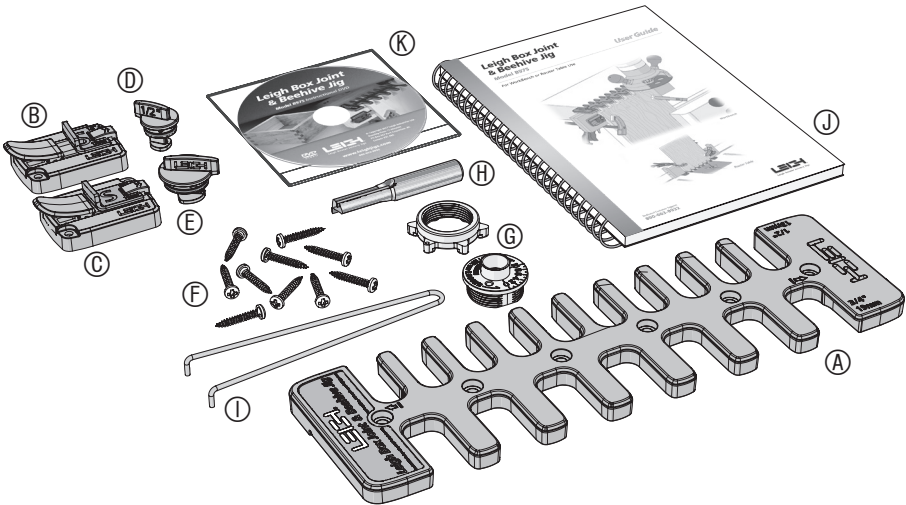

What's Included

	PART DESCRIPTION	PART NO.	QUANTITY
	Ⓐ Jig Template with Decal	313503	1
Bag 1	Ⓑ Side Stop Assembly, 1/2"	313530	1
	Ⓒ Side Stop Assembly, 3/4"	313535	1
	Ⓓ Step-over Cam with O-ring, 1/2"	313550	1
	Ⓔ Step-over Cam with O-ring, 3/4"	313555	1
Bag 2	Ⓕ Pan Head Wood Screws, No.8 x 1"	313585	10
	Ⓖ Guide Bushing, e10* eBush	e10	1
	Ⓗ Straight Bit, 1/2"	160	1
	Ⓘ Pin Wrench	730V	1
Bag 3	Ⓙ Fully Illustrated User Guide	313565	1
	Ⓚ Instructional DVD	313570	1

Note: PDF of User Guide included on DVD

If any parts are missing from your jig, please notify your supplier or Leigh immediately. See Chapter 9, Customer Support.

Leigh Box Joint & Beehive Jig

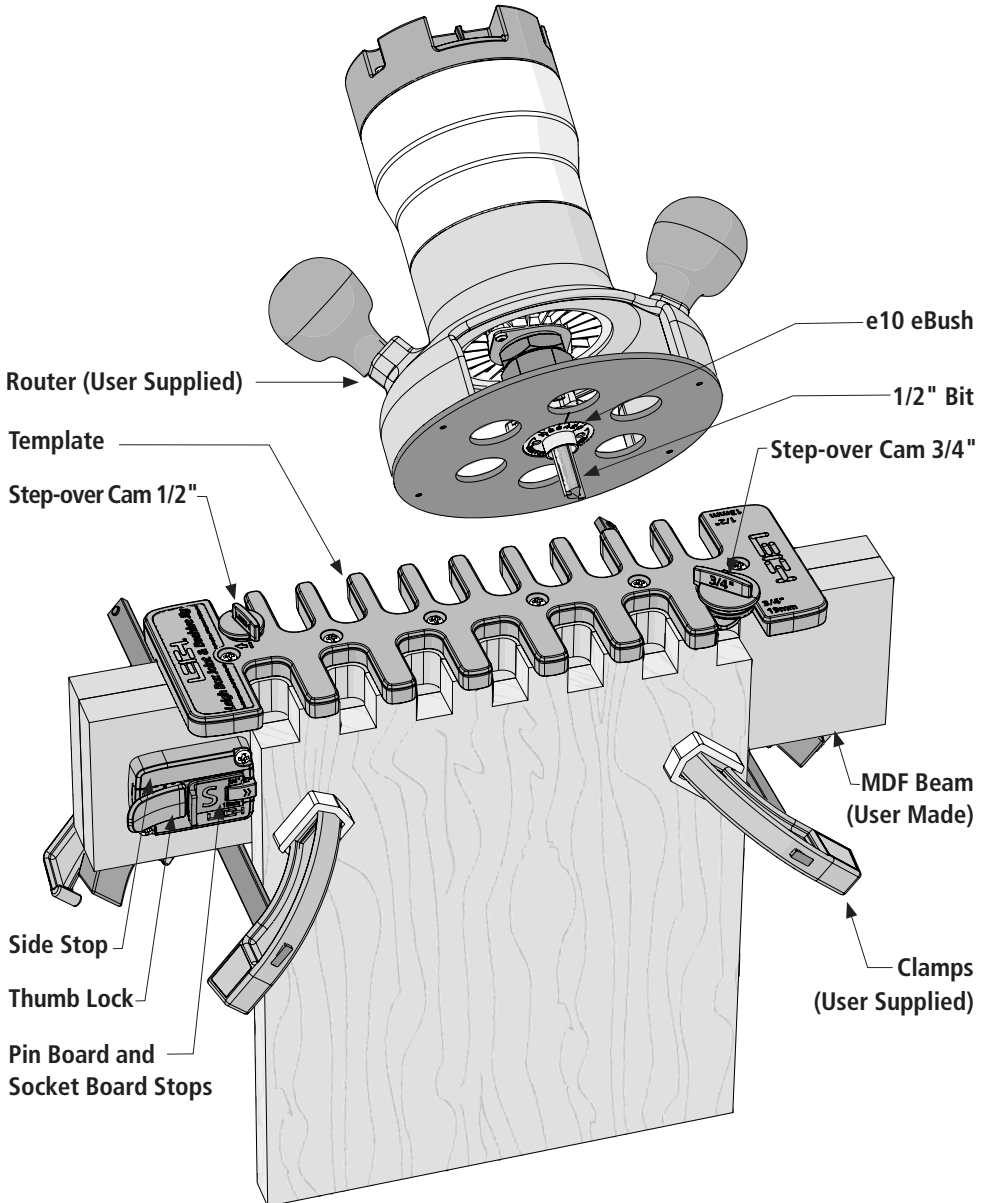

Units of Measure



IMPORTANT! INCHES AND MILLIMETERS

Text and illustrations in this English language user guide indicate dimensions in both inches and millimeters, where applicable, with “inches” first, followed by “millimeters” in square brackets, i.e. 1/2" x 2"[12.7mm x 51mm].

Don't be concerned that the inch/millimeter equivalents are not mathematically "correct".

Bit Specifications

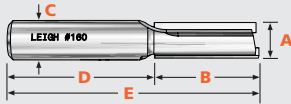
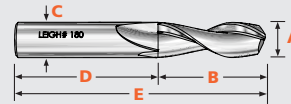
There is only one bit size used with the Box Joint & Beehive Jig. Your new jig is shipped with a 1/2", 2 flute, carbide tipped straight bit. You may also use a 1/2" spiral up cut bit in high speed steel or solid carbide.

Bit Specifications							
Leigh Bits	A Bit Diameter	B Max. Cutting Depth	C Shank Diameter	D Shank Length	E Overall Length	Use with Collet/ Collet reducer	Use with eBush
 160* Carbide tipped	1/2"	1-1/4"	1/2"	1-7/8"	3-1/8"	1/2" Collet	e10
 180** High Speed Steel	1/2"	1-3/4"	1/2"	1-3/4"	3-1/2"	1/2" Collet	e10
 180C** Solid Carbide	1/2"	1-5/8"	1/2"	1-7/8"	3-1/2"	1/2" Collet	e10

* 160 bit comes with the Beehive Box Joint Jig

** Optional spiral up cut bits rout cleaner and faster, leaving a smoother finish

Symbols for Board Position

The following symbols are used throughout this user guide. They indicate which edge of the board goes against the side stop.

◀ This board edge against the side stop.

⦿ This board edge against the side stop (on other side of the board hidden from view).

Clamping

Note: Before mounting and routing the boards, you should mark them with the appropriate symbols. With box joints, the same board edge ① always goes against the side stop.

Boards are clamped against the beam both face in and face out for alternate end cuts.

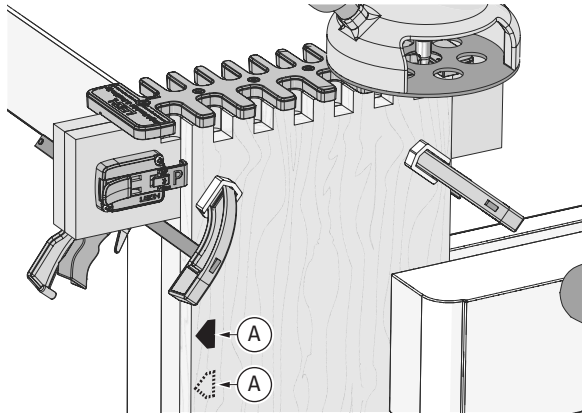

Box Assembly

Assemble the box, keeping the marked edges of the boards together as shown.

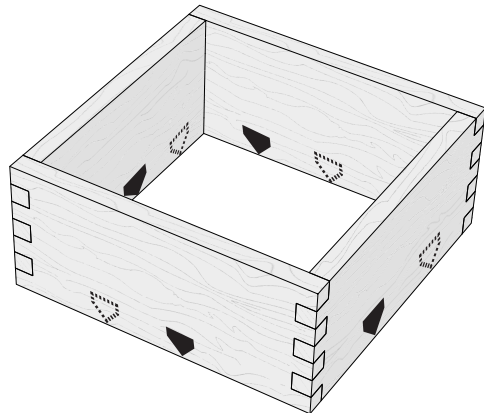

B975 User Guide

CHAPTER 2 Safety

Safety is not optional. Read and follow the recommendations here.

Read the owner's manual that came with your router and router table. It is essential to understand all manufacturer's instructions completely.

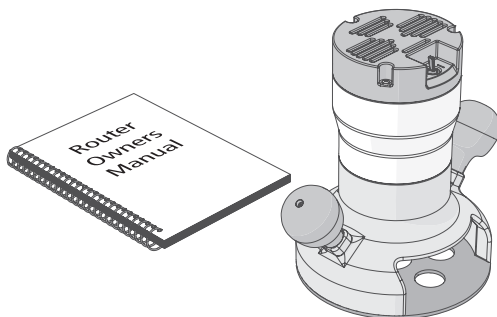

⚠ Always wear:

- approved safety glasses;
- a face mask to protect yourself from harmful dust;
- hearing protection.



⚠ Never drink alcohol or take medications that can cause drowsiness while operating a router.



⚠ Always disconnect the power source before installing bits, guide bushings or making adjustments. Before reconnecting the router to the power source, make sure the bit and collet revolve freely with and without the guide bushing in place.

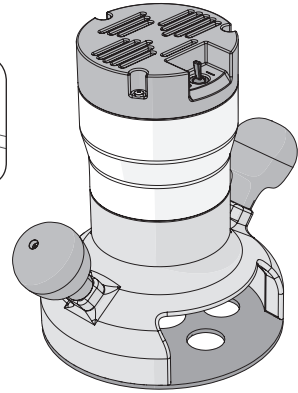
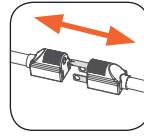

After routing, wait for the bit to come to a complete stop before removing the router from the jig.

⚠ Do not tilt the router. Keep the router flat on the jig during all routing.

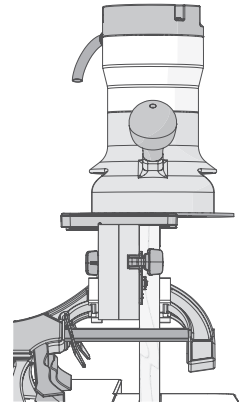
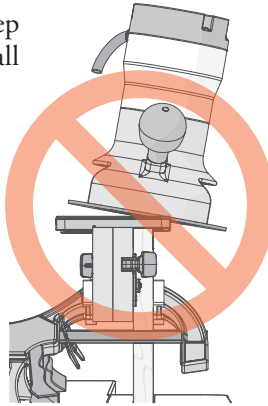

⚠ Never rout at face level. Chips and sawdust are thrown out at high speed. ■

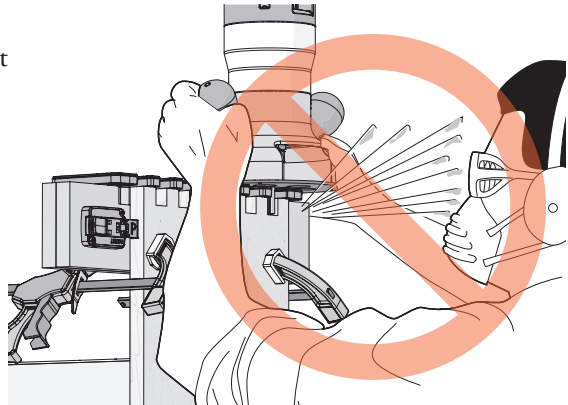

B975 User Guide

CHAPTER 3 The Leigh e10 eBush

Note: Normal tolerances with bits, guide bushings and router runout will generally produce poor fitting joints. The included Leigh e10 elliptical guide bushing (eBush) solves this problem.

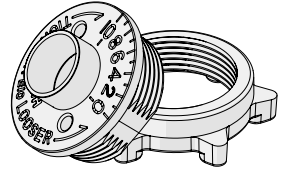

Patents for Leigh elliptical guide bushings: U.S. 9,375,860 UK GB2443974

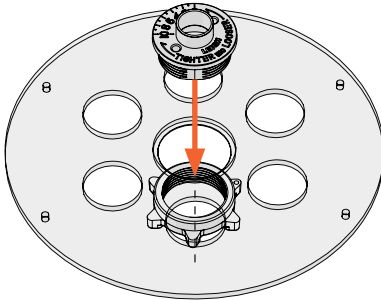

3-1 How the e10 Works

Routing on the B975 requires a router fitted with the included e10 eBush (guide bushing).

The e10 is installed in the base of the router and the guide bushing retaining nut is screwed on, under the router base.

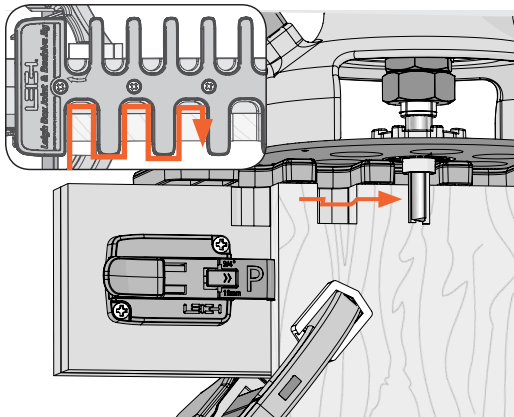

3-2 The barrel of the e10 steers the router and the bit in and around the openings of the template.

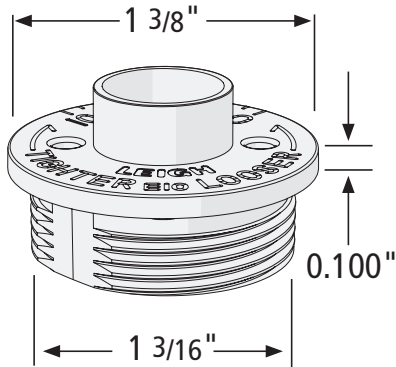

3-3 The Leigh eBush System is designed around the 1-3/8" industry standard. Some routers accept the Leigh eBush directly. Many routers require the use of a guide bushing adapter. If your router requires an adapter, please see the Guide Bushing Adapter chart and Leigh guide bushing adapters in Chapter 8.

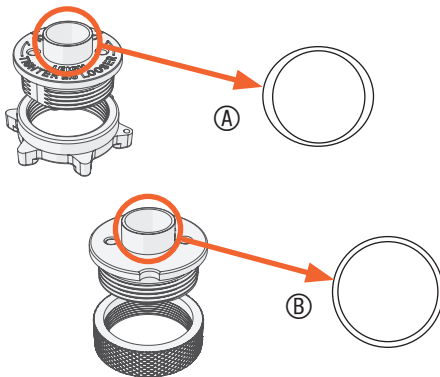

3-4 The Leigh eBush barrel (A) is elliptical, unlike plain circular template guide bushings (B). When the e10 is rotated, the effective diameter of the barrel changes, allowing fit adjustments as small as 0.001" [0.025mm]. The e10 eBush is included with the jig.

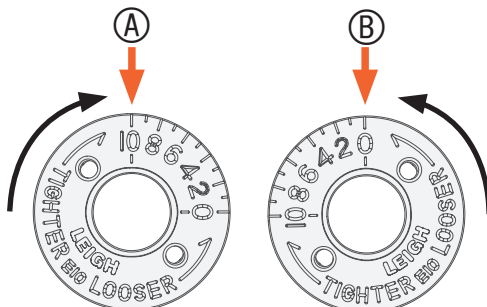

3-5 All routing starts with the eBush in the No.5 position.

This allows adjustment for a tighter or looser fit. Turning the eBush toward the 10 position (A) results in a tighter fit. Turning the eBush toward the 0 position (B) results in a looser fit. **Be sure to retighten the e-Bush nut after each adjustment.**

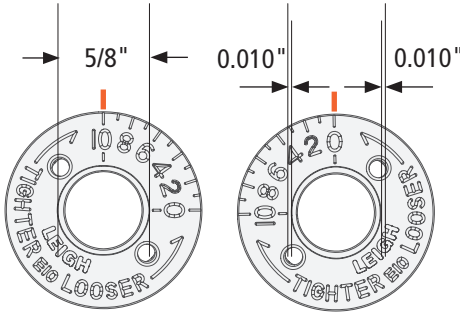

3-6 Joint Fit Adjustment The effective diameter of the e10 is 5/8" at the 10 position. Rotating the eBush to the 0 position reduces the effective diameter by 0.020" [0.5mm].

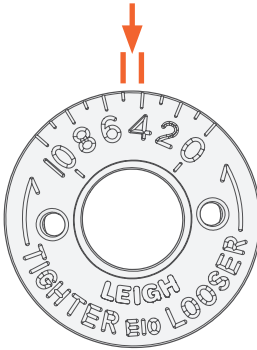

3-7 One increment of the eBush changes the joint glue line by 0.002" [0.05mm]. Half an increment changes the fit by an incredible 0.001" [0.025mm]. A perfect fit will be established with one or two test cuts.

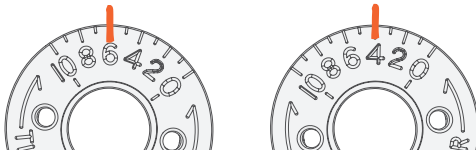

Feb. 28, 1/2" joint
Maple, 160 bit

May 5, 3/4" joint
Walnut, 160 bit

3-8 Each chapter provides a place to mark your perfect eBush setting, for easy repeatability the next time.

EXAMPLE ONLY

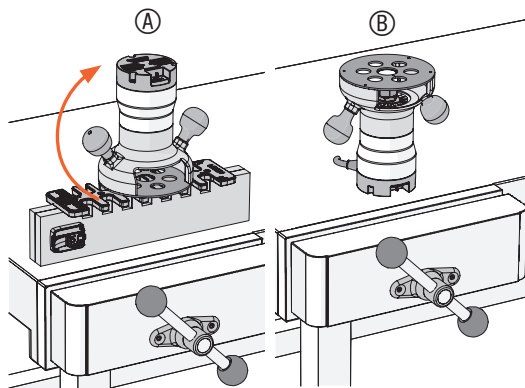

3-9 Fitting the eBush to the Router. Place the router on the jig with handles positioned the way you would normally hold the router **(A)**. Then turn the router upside down and place it on the workbench **(B)**, keeping the same face of the router toward you.

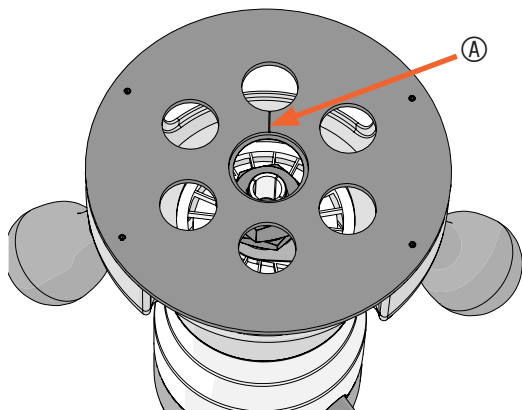

3-10 Make a small scratch line on the router base or eBush adapter, at the 12 o'clock position. This will be a reference line for all eBush settings **(A)**.

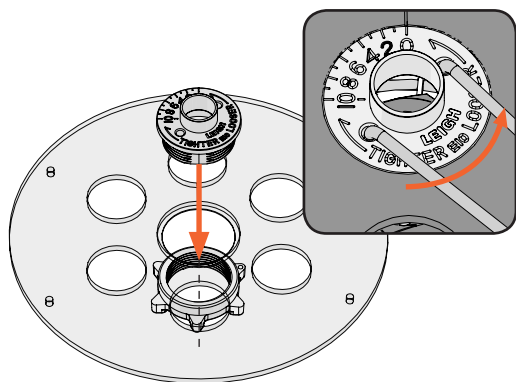

3-11 Install the **e10-Bush** in the router base and use the pin wrench to align the 0 to the reference line. The 0 setting is only used for beam preparation. All other routing begins with the eBush set to 5.

Be sure to retighten the eBush nut after each adjustment. ■

B975 User Guide

CHAPTER 4 Mounting & Assembly

The instructions on the following pages will guide you through the assembly process for the Leigh B975.

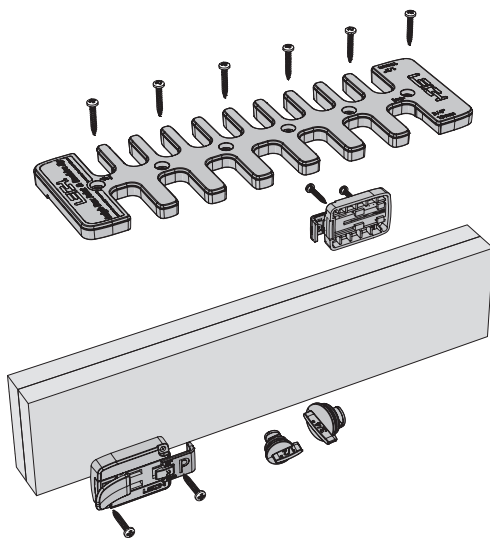

You will need:

- A workbench with vice or a portable workbench
- 2 pieces of 3/4" MDF to make a beam 1-1/2" x 3-1/2" x 16" [38mm x 90mm x 406mm]
- Router with 1/2" collet
- Electric drill, preferably bench or pedestal, but handheld will work
- 1/8" drill bit
- Two Quick-Grip clamps
- Square, ruler or tape measure
- No.2 Phillips screwdriver
- Wood Glue

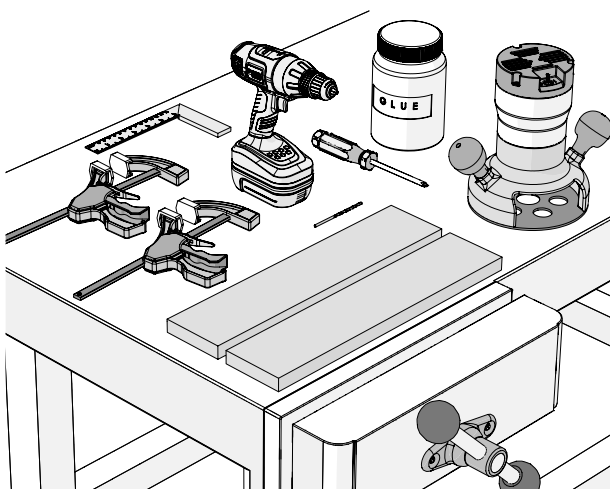

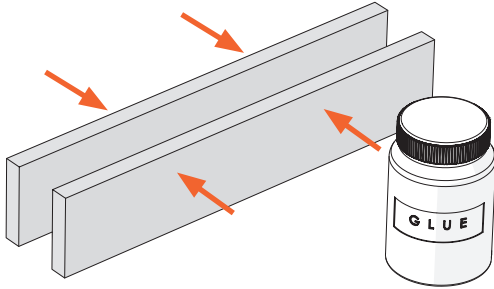

4-1 Making the Beam We recommend laminating the two pieces of 3/4" MDF. Place the glued pieces in a vice or use clamps to hold them together. The template will be attached to the top of the beam, so be sure the top edges are flush and free of glue residue. Set aside to dry completely. Alternatively, a common 2x4 may be used. See step 4-15 for special instructions.

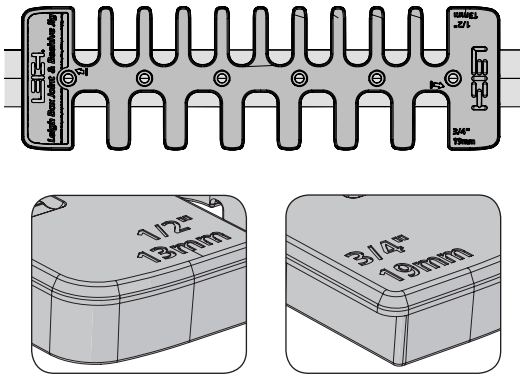

4-2 One side of the template is used for 3/4" box joints and the other side is used for 1/2" joints.

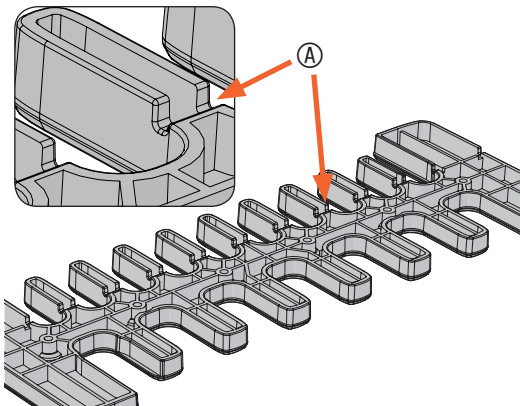

4-3 The 1/2" comb has positioning ridges **A** molded into the bottom side of the template.

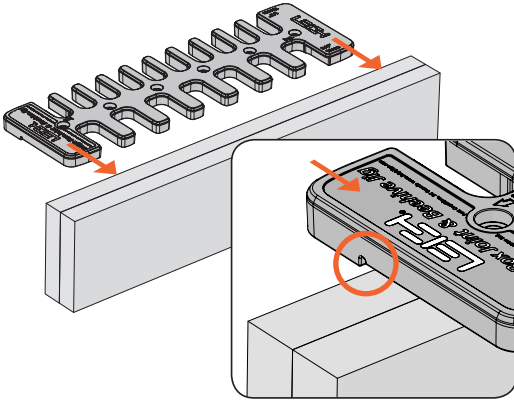

4-4 With the 3/4" comb facing you, lay the template flat on the beam and center it left to right. Slide the template forward until the ridges on the underside of the 1/2" comb contact the back of the beam. The template is now positioned correctly.

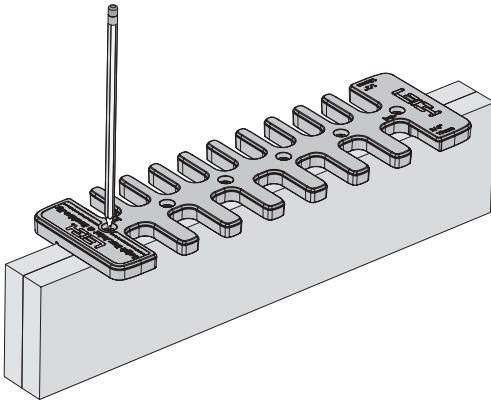

4-5 Use a pencil and mark the location of all screw holes on the top of the template. Hold the template in place and proceed to the next step.

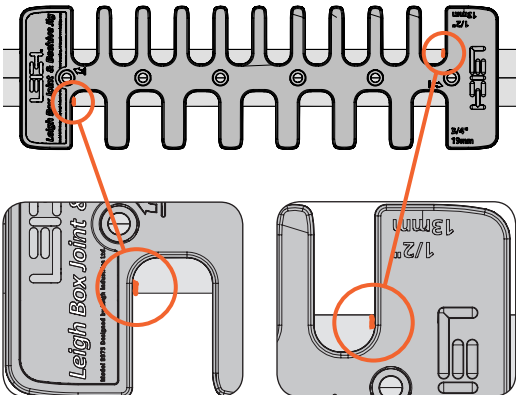

4-6 Make a pencil line on the top of the beam at each end of the jig on the 3/4" and 1/2" sides.

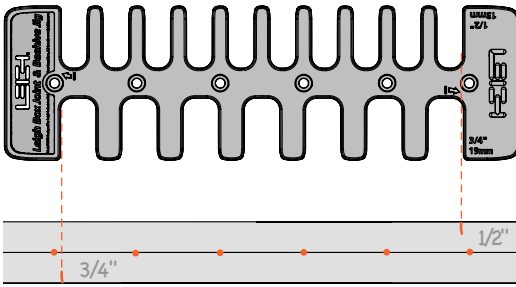

4-7 Remove the template and mark $3/4"$ and $1/2"$ beside the lines, to indicate which is the $3/4"$ and which is the $1/2"$ side of the beam.

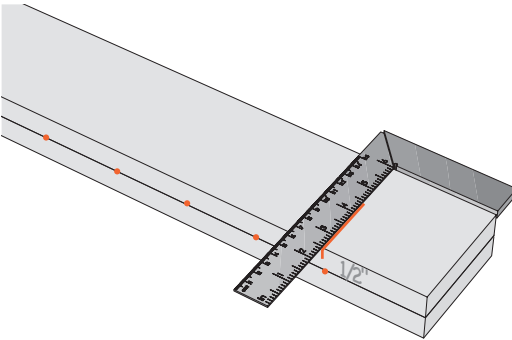

4-8 Mark layout lines for the side stops. First, place the beam flat on the workbench with the $1/2"$ side of the beam facing up. Use a square and draw a vertical line down from the positioning mark on the top of the beam.

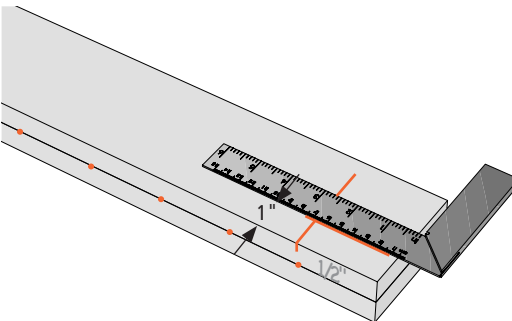

4-9 Next, draw a horizontal line, $1"$ down from the top of the beam.

Rotate the beam and repeat for the $3/4"$ side.

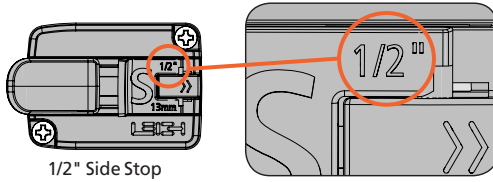
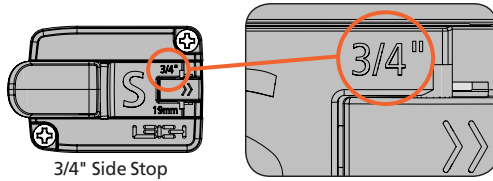

4-10 The 3/4" and 1/2" side stops will be attached in the following steps.

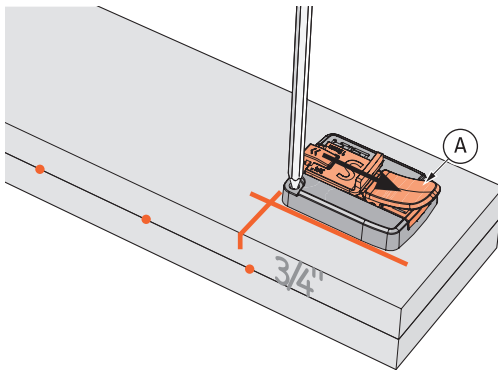

4-11 Install the 3/4" side stop. Lift the thumb lock (A), retract the center portion of the 3/4" side stop fully and press the thumb lock down to lock it in place. Position it against the layout lines as shown.

Use a pencil to mark the screw hole locations.

Rotate the beam and repeat the process for the 1/2" side.

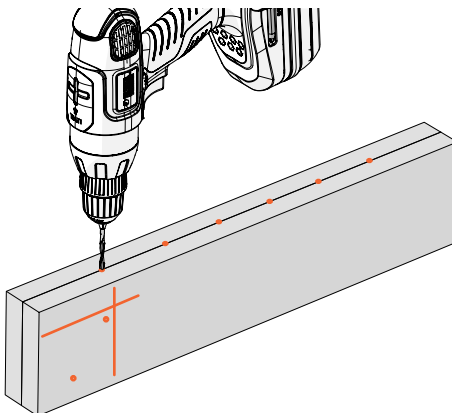

4-12 Use a drill press or hand drill with a 1/8" bit to drill pilot holes at all screw hole locations.

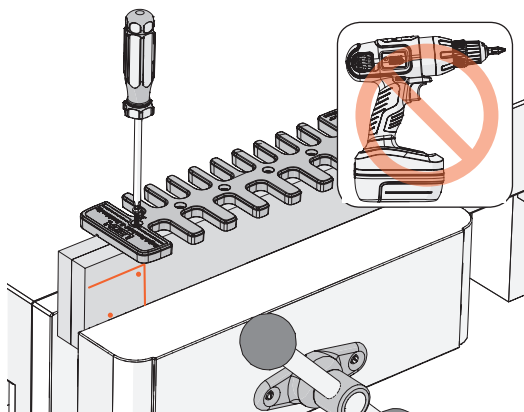

4-13 Clamp the beam in the vice with its 3/4" side facing you. Position the template on the beam with the 3/4" side of the template facing you. Align it with the pre-drilled holes.

Use a screwdriver to attach the template with six of the included screws. **⚠ Do not use a power drill, as this may overstress the template.**

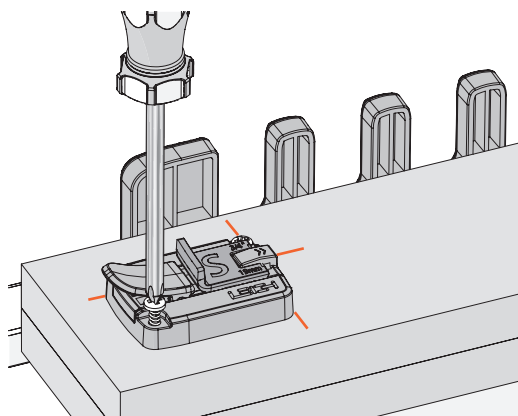

4-14 Place the beam on the workbench with the 3/4" side of the beam facing up. Position the 3/4" side stop against the horizontal and vertical lines, with the thumb lock facing the left end of the beam, and attach it using the included screws. Again, use a screwdriver, not a power drill, to attach the side stop.

Repeat the process with the 1/2" side stop on the 1/2" side of the beam.

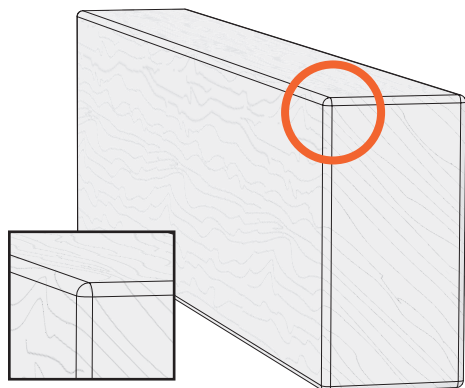

4-15 Alternatively, you can use a straight, flat 16" [406mm] piece of common 2x4. Since a 2x4 has slightly rounded corners, the top edge should be squared off.

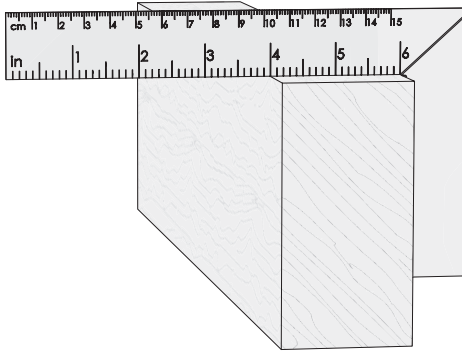

4-16 Use a table saw, router table or jointer to skim off the top surface of the 2x4. Now go back to step 4-7 for the rest of the beam preparation.

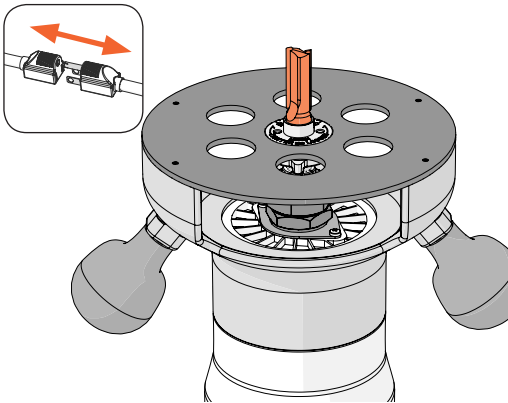

4-17 Install the Bit

Install the No.160 1/2" straight bit (or equivalent) in the router. The bit goes through the guide bushing and fits in the router collet.

Tighten the collet and rotate the bit and collet to ensure it spins freely and does not contact the eBush or eBush nut.

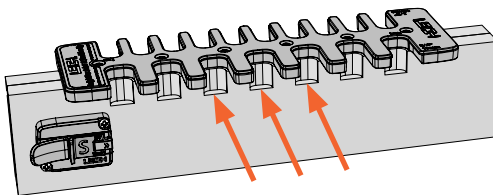

4-18 Prepare the Beam

To prevent tearout of the beam, grooves must be routed in all template openings, on both sides of the beam, as shown in the following steps.

Preparing the beam is particularly important when using a common 2x4 because its side grain will tear out badly.

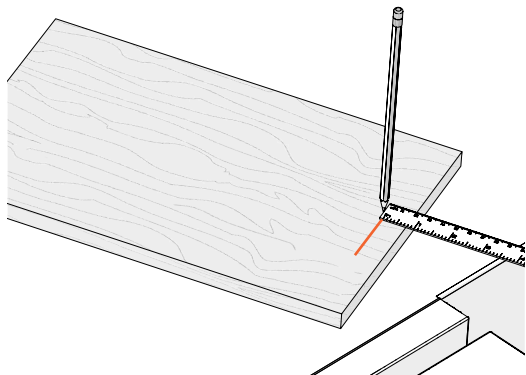

4-19 Depth of Cut

Select a board at least 9-3/4" [248mm] wide and 1/2" to 3/4" thick. Length is not important as long as it can be clamped safely in the vice.

Set the depth of cut by marking a line 3/4" from the top end of the board. Clamp the board in the vice with the depth of cut line facing you.

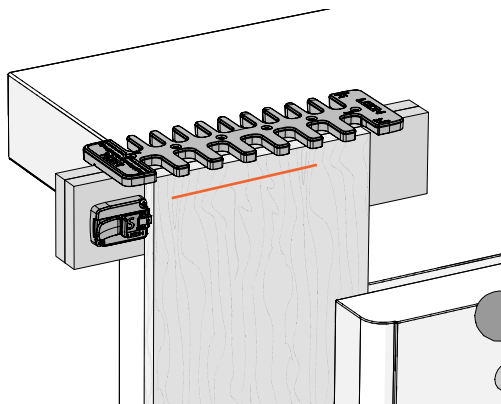

4-20 With the socket board stop fully retracted, and the 3/4" side of the jig facing you, lower the jig onto the board. Slide the jig over until the left edge of the board touches the socket board stop as shown.

Clamp the jig in place.

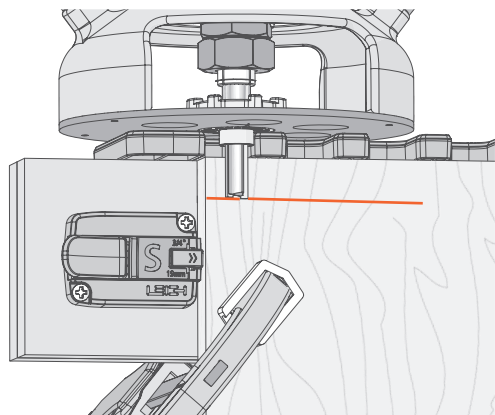

4-21 Place the router on the jig and adjust the tip of the bit up or down until it's at the center of the line. Rotate the bit and collet to ensure it spins freely and does not contact the eBush.

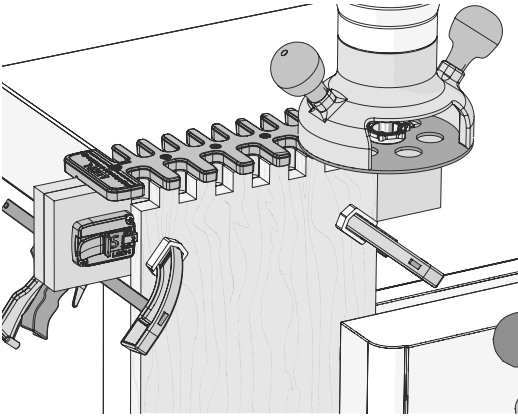

4-22 Hold the router firmly and rout through the board and into the beam, in each template opening. Be sure the guide bushing touches the left side of each template opening on the way in and the right side on the way out.

Use the other end of the board and repeat for the 1/2" side of the jig.

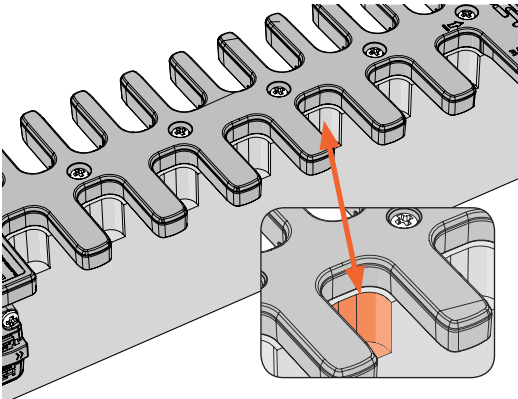

4-23 There will now be a clean groove in each template opening on both sides of the beam.

The beam and jig are now ready to use. ■

This page is left blank intentionally.

B975 User Guide

CHAPTER 5 Routing Box Joints

Note: Routing Procedures for 3/4" and 1/2" joints are identical. This chapter shows steps for 3/4" joints.

IMPORTANT SAFETY NOTE

Before using your Leigh B975, you must have completed the preparatory steps listed in the previous pages, including reading the jig safety recommendations in Chapter 2.

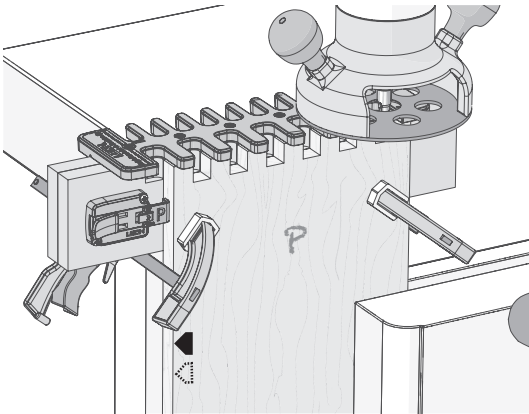

5-1 Getting Started The steps in this chapter show the jig used on a workbench. For router table operation, see Chapter 7.

5-2 Parts Required 3/4" and 1/2" box joints are routed with the included Leigh No.160 1/2" straight bit and the Leigh e10 guide bushing (eBush). **No other bit diameter and guide bushing combination may be used.** Maximum board thickness for both joint sizes is 13/16" [20.6mm]. Depth of cut can be increased beyond the board thickness for raised joints. **Note:** Optional 1/2" diameter spiral upcut bits may also be used.

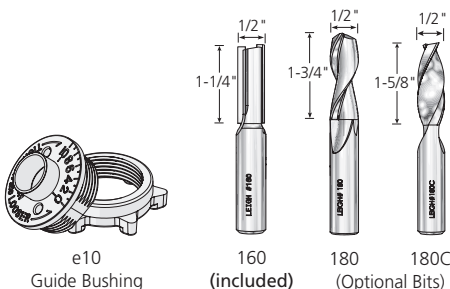

Bit Cutting Depth

Bit Diameter	1/2"
Item No. Carbide Tipped	160
Item No. Spiral HSS (Optional)	180
Item No. Spiral Solid Carbide (Optional)	180C

Depth of Cut	0"	1/4"	1/2"	3/4"	13/16"
0"					
1/4"					
1/2"					
3/4"					
13/16"					

5-3 Joint layout Review the drawings below. **Symmetrical** joints have pins (A) on both edges of the pin board, and sockets (B) on both edges of the socket board. **Asymmetrical** joints have a pin (C) on one edge and a socket (D) on the other edge of each board.

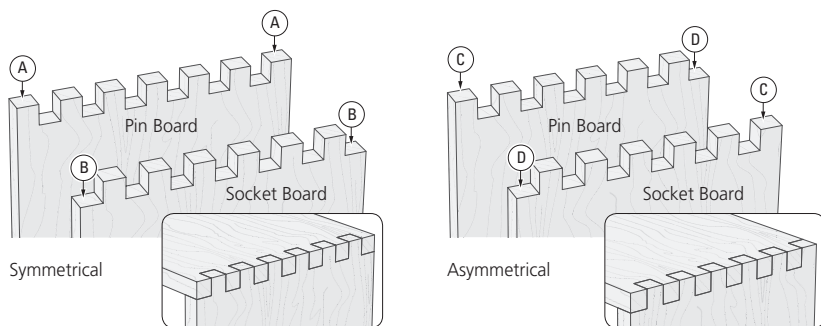

5-4 Board Width Selection Board widths are determined by the total number of pins and sockets in the joint design and whether the joint is symmetrical or asymmetrical. Use this chart to determine board widths up to the full width of the jig: 9-11/16" [246 mm]. Routing box joints on wider boards will be covered in Chapter 6.

Symmetrical Board Widths for 3/4" Box Joints

Total Pins & Sockets	3	5	7	9	11	13
Inches	2 3/16"	3 11/16"	5 3/16"	6 11/16"	8 3/16"	9 11/16"
Millimeters	56	94	132	170	208	246

Asymmetrical Board Widths for 3/4" Box Joints

Total Pins & Sockets	4	6	8	10	12
Inches	2 15/16"	4 7/16"	5 15/16"	7 7/16"	8 15/16"
Millimeters	75	113	151	189	227

Symmetrical Board Widths for 1/2" Box Joints

Total Pins & Sockets	3	5	7	9	11	13	15	17	19
Inches	1 7/16"	2 1/2"	3 1/2"	4 1/2"	5 9/16"	6 9/16"	7 5/8"	8 5/8"	9 5/8"
Millimeters	37	63	89	115	141	167	195	219	245

Asymmetrical Board Widths for 1/2" Box Joints

Total Pins & Sockets	4	6	8	10	12	14	16	18
Inches	1 15/16"	3"	4"	5 1/16"	6 1/16"	7 1/16"	8 1/8"	9 1/8"
Millimeters	50	76	102	128	154	180	206	232

5-5 Board Width Selection Board widths indicated in the chart will produce full size pins and sockets at each board edge, for symmetrical or asymmetrical joints. Symmetrical joint board widths may be reduced as required, resulting in smaller but equally sized pins and sockets at each board edge. If board widths are reduced for asymmetrical joints, one edge of the board will have a full size pin and socket while the other board edge will have a smaller pin and socket. This may result in an unattractive joint.

Symmetrical

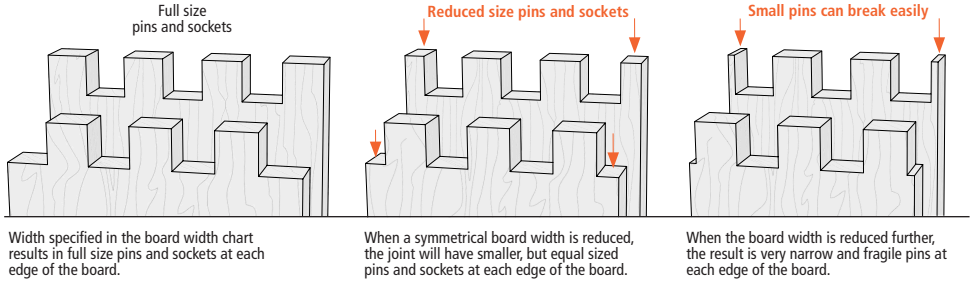

Asymmetrical

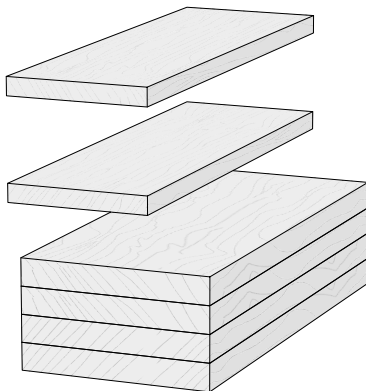
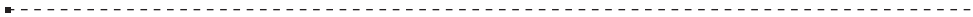
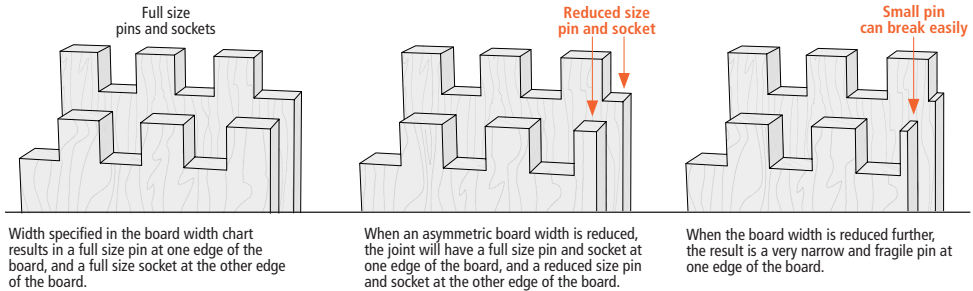

⚠ IMPORTANT: Read this chapter before routing any boards.

5-6 Making a Box Prepare four similar boards 3/4" thick × 5-3/16" wide by about 12" long [19mm×133mm×305mm], and two test boards, about 4" [100mm] wide and the same thickness.

Note: Boards of different thicknesses may also be joined.

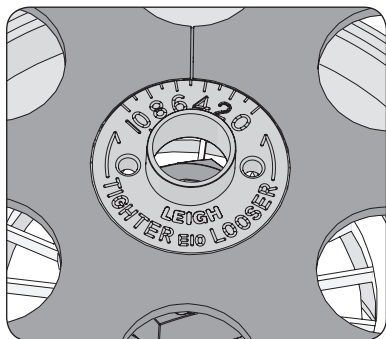

5-7 Routing a Test Fit Joint

Test joints are always routed with the eBush set at the 5 position.

Retighten the eBush nut after each guide bushing adjustment.

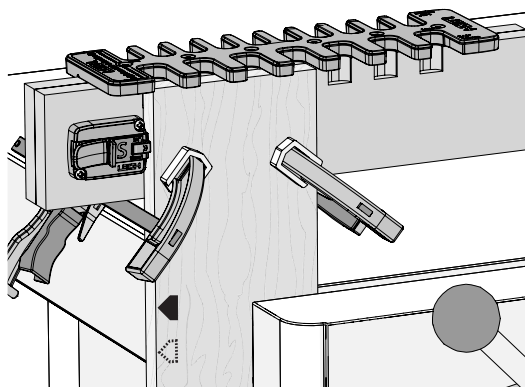

5-8 Clamp one of the test boards in the vice. Using the 3/4" side of the jig, position the left end of the jig over the test board and clamp in place.

Board alignment is not important when routing a test fit.

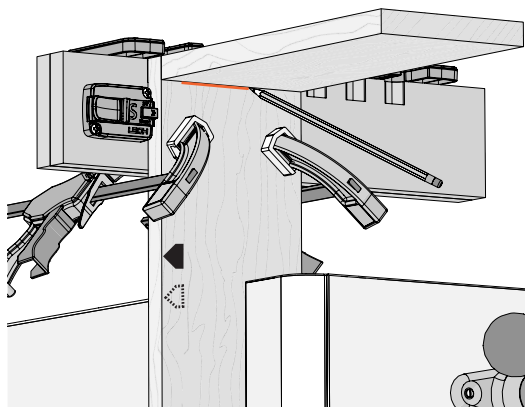

5-9 Socket and pin boards may differ in thickness. Always use the mating pin or socket board to determine depth of cut. Hold it flush under the template and mark a line on the board, indicating depth of cut.

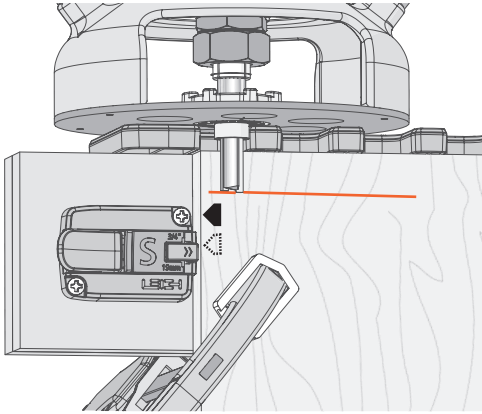

5-10 Place the router on the jig and adjust the tip of the bit up or down until it's at the center of the line. Rotate the bit and collet to ensure it spins freely and does not contact the eBush.

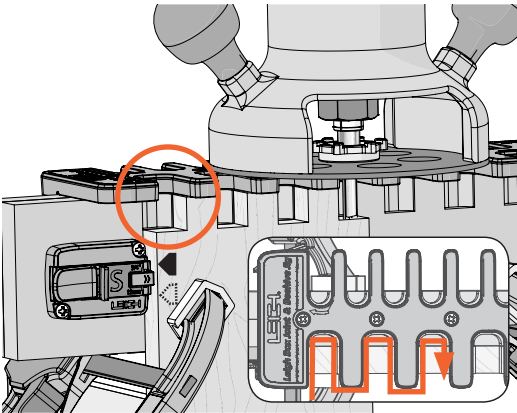

5-11 Rout the first test board. Hold the router firmly as you rout straight in and out of each template opening. Be sure the e10 guide bushing touches the left side of the template opening on the way in, and the right side on the way out. **Do not rotate the router.**

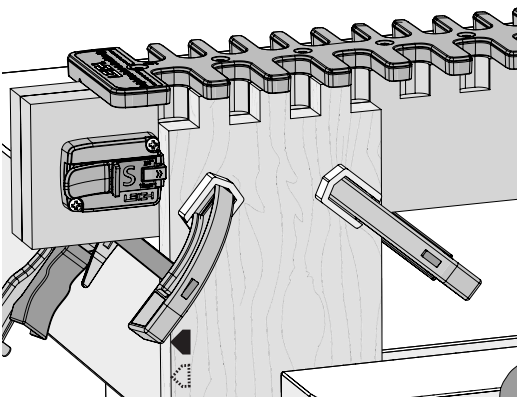

5-12 Remove the jig from the first test board and repeat the process for the second test board.

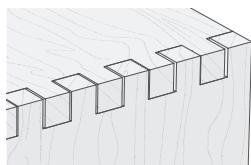

TOO LOOSE

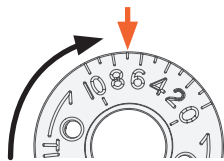

TIGHTEN

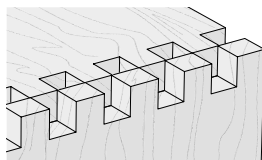

TOO TIGHT



LOOSEN

5-13 Joint Fit Adjustment

Assemble the test boards. If the joint is too loose, use the pin wrench and turn the eBush to a higher number **and rout two fresh board ends.**

If the joint is too tight, turn the eBush to a lower number **and rout two fresh board ends.**

One or two test cuts should produce a perfect fit.

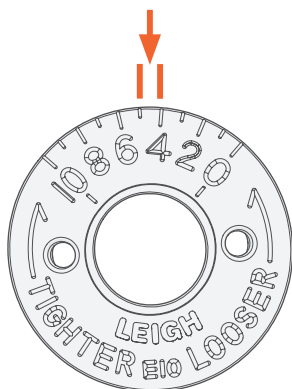

5-14 Each increment on the eBush changes the joint glue line fit by 0.002" [0.05mm]. Half an increment, a mere 0.001"!

Retighten the eBush nut after each guide bushing adjustment.

SAMPLE



June 7, 1/2" joint
Maple, 160 bit



5-15 Use these eBush diagrams to record the settings you used to achieve perfect joint fit. The first eBush is simply an example of how to record your setting.

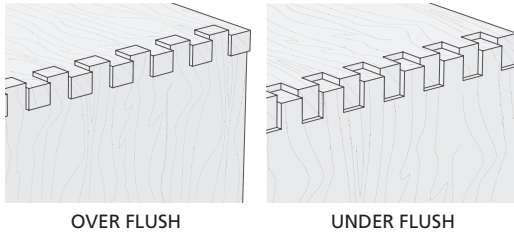

5-16 Joint flushness is determined by the depth of cut.

If the joint is over flush, raise the bit to decrease the depth of cut.

If the joint is under flush, lower the bit to make a deeper cut.

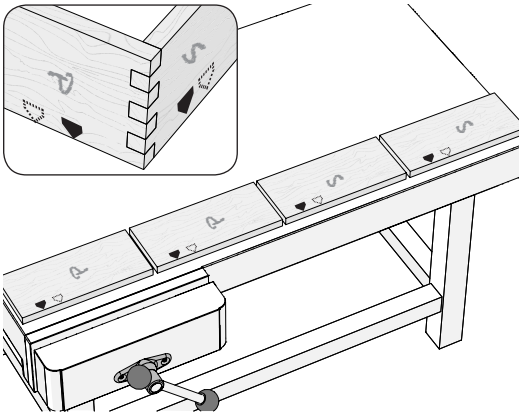

5-17 Lay out the four boards for the box. Mark an **S** (socket board) on two of the boards and a **P** (pin board) on two boards.

Also mark the common board edges that will go against the side stop. These edges will align at the top or bottom edge of the box when assembled.

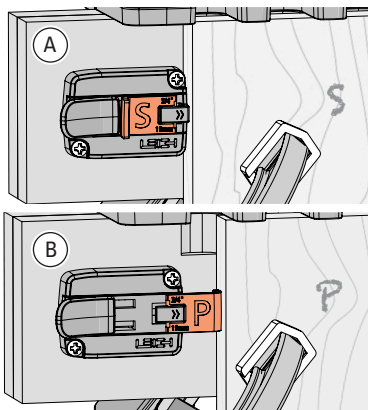

5-18 Side Stop Positions The side stop is used to position the pin and socket boards. Put the socket board stop in the **S** position **A** for all socket boards. The pin board stop is put in the **P** position **B** for all pin boards.

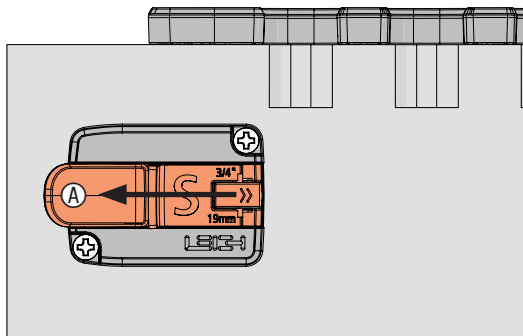

5-19 Routing the Socket Board

With the $\frac{3}{4}$ " side of the template facing you, lift the thumb lock (A) and move the socket board stop fully to the left. Lock it in position.

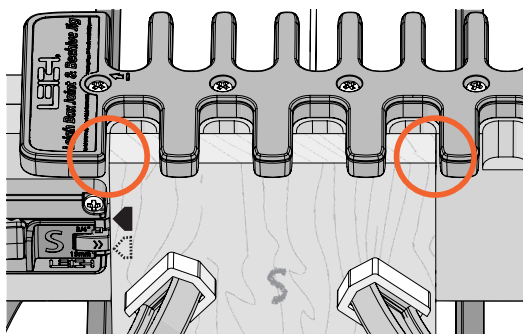

5-20 Symmetrical Joints

Clamp the first socket board in the vice. With the left edge of the board in the first template opening, position the jig over the socket board, leaving equal amounts of the board showing at each edge. Clamp the jig in place.

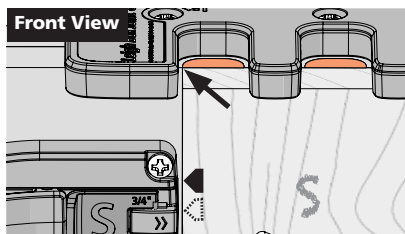
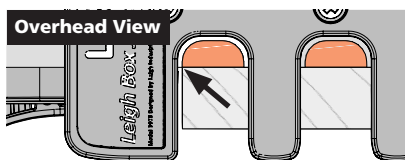

5-21 Asymmetrical Joints

Clamp the first socket board in the vice. With the left edge of the board in the first template opening, position the jig over the socket board.

Note: Asymmetrical boards cannot be centered under the template. With the side stop fully retracted, align the left edge of the board with the left edge of the groove in the beam.

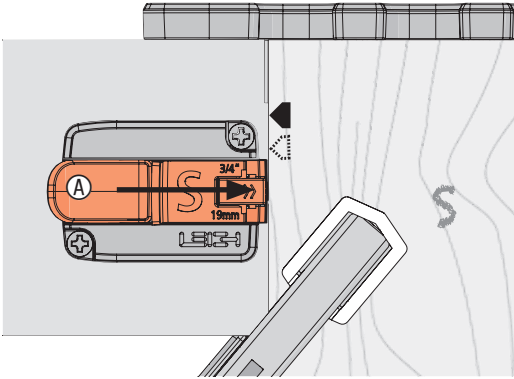

5-22 For both joint types, lift the thumb lock (A), and move the socket board stop to the right until it touches the board. Press the thumb lock to lock it in place.

The side stop remains locked in place for all socket and pin board routing.

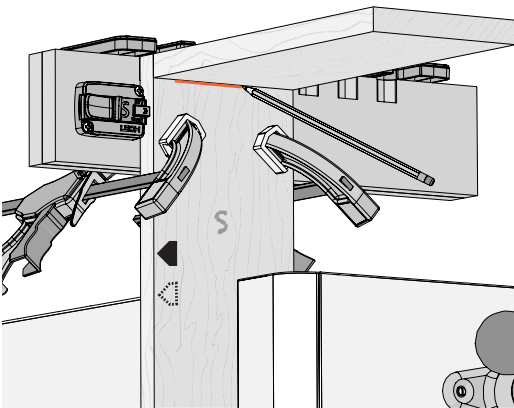

5-23 Socket and pin boards can be different thicknesses. Always use the mating pin or socket board to determine depth of cut.

In this case, hold the pin board flush under the template and draw a line on the socket board, indicating depth of cut.

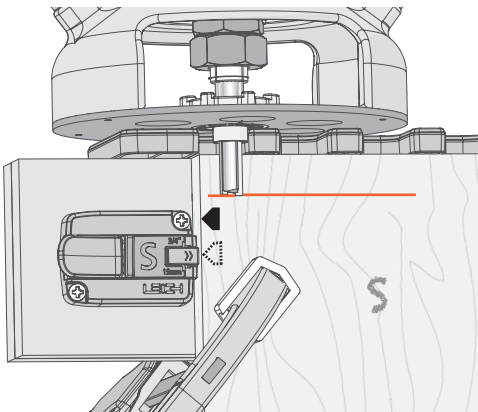

5-24 Place the router on the jig and adjust the tip of the bit up or down until it's at the center of the line. Rotate the bit and collet to ensure it spins freely and does not contact the eBush.

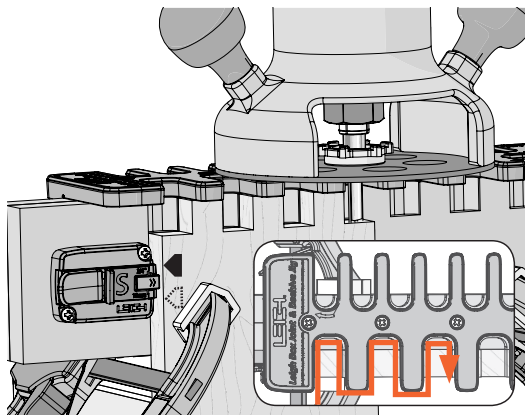

5-25 Hold the router firmly, as you rout straight in and out of each template opening.

Be sure the e10 guide bushing touches the left side of the template opening on the way in, and the right side on the way out. **Do not rotate the router. Keep the router handles parallel to the jig while routing.**

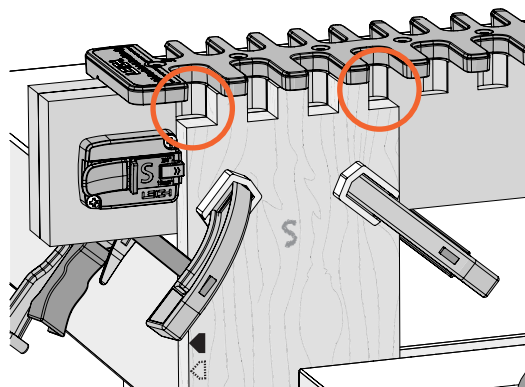

5-26 There will now be a full socket at each edge of the socket board.

Turn the socket board end for end, keeping the same board edge against the side stop.

Rout the other end of the board. Repeat for the second socket board and remove the jig from the socket board.

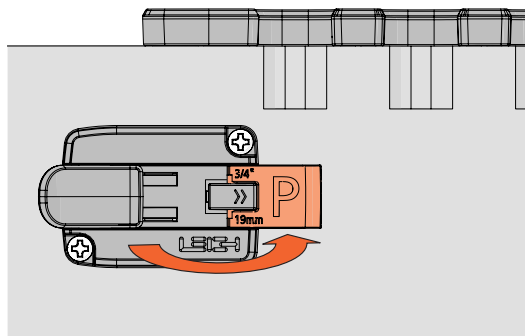

5-27 Routing the Pin Board

The pin board must be offset relative to the socket board. Do not release the thumb lock. Simply flip the pin board stop to the **P** position.

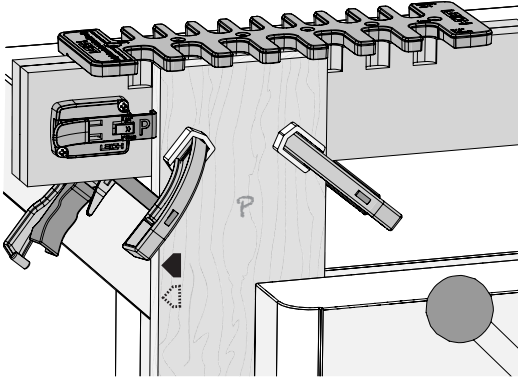

5-28 With the side stop set, position the jig over the pin board, and slide it over until the side stop touches the board edge. Clamp in place.

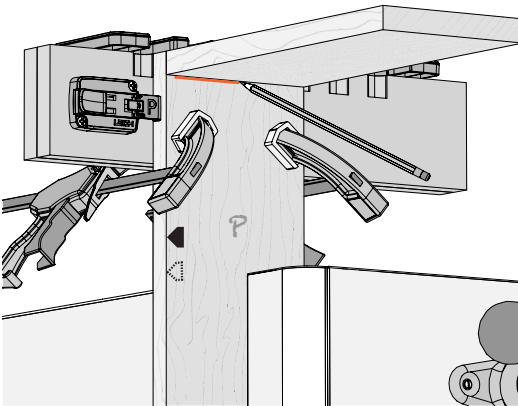

5-29 Use the socket board to mark the depth of cut. If all your boards are the same thickness, the depth is already set.

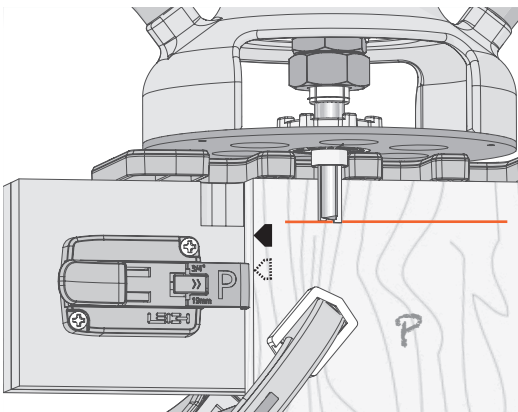

5-30 Place the router on the jig and adjust the tip of the bit up or down until it's at the center of the line.

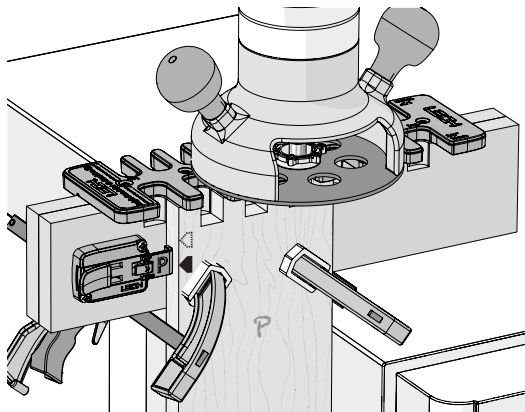

5-31 Hold the router firmly as you rout straight in and out of each template opening. Be sure the e10 guide bushing touches the left side of the template opening on the way in, and the right side on the way out.

Do not rotate the router.

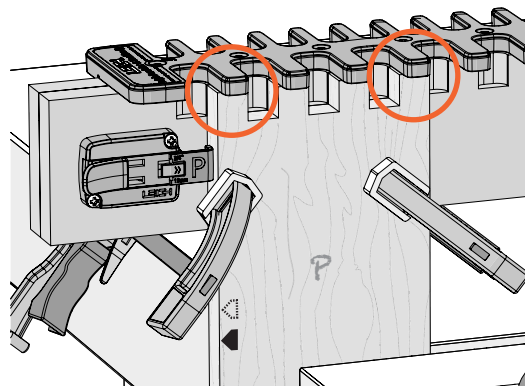

5-32 There will now be a full pin at each edge of the board.

Turn the pin board end for end, keeping the same board edge against the side stop, and rout the other end of the board. Repeat for the second pin board.

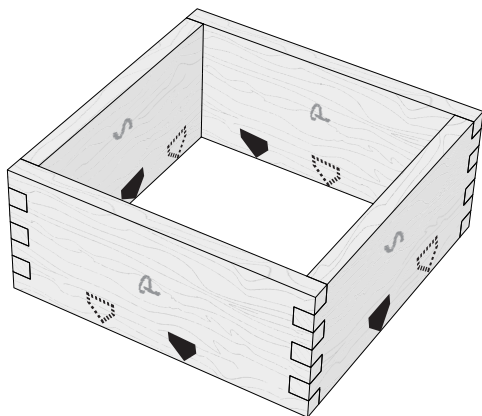

5-33 Assemble the box, keeping the marked board edges aligned. ■

B975 User Guide

CHAPTER 6 Routing Wider Boards

This chapter assumes you are familiar with all procedures in this user guide and you have established good joint fit and flushness using test boards before routing wide boards.

IMPORTANT SAFETY NOTE

Before using your Leigh B975, you must have completed the preparatory steps listed in the previous pages, including reading the jig safety recommendations in Chapter 2.

6-1 Getting Started The Box Joint & Beehive Jig can be used to rout box joints on boards wider than the jig width, up to 17-13/16" [453mm]. This is accomplished easily using a step-over cam and simple procedure. **This example uses 3/4" box joints on 3/4" thick boards.** Procedures for routing 1/2" and 3/4" joints are identical.

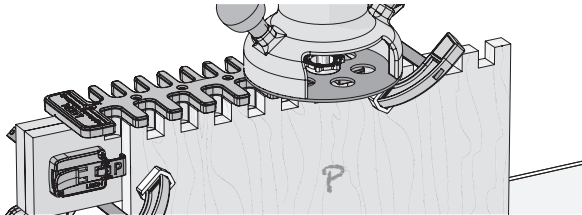

6-2 Parts Required 3/4" and 1/2" box joints are routed with the included Leigh No.160 1/2" straight bit and the Leigh e10 guide bushing (eBush). **No other bit diameter and guide bushing combination may be used.** Maximum board thickness for both joint sizes is 13/16" [20.6mm]. Depth of cut can be increased beyond the board thickness for raised joints. **Note:** Optional 1/2" diameter spiral upcut bits may also be used.

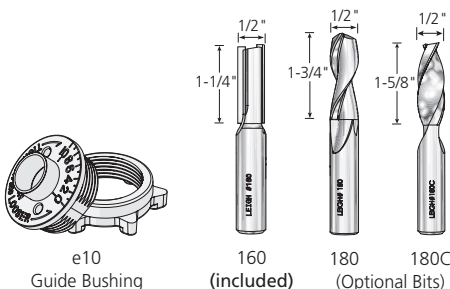

Bit Cutting Depth

Bit Diameter	1/2"
Item No. Carbide Tipped	160
Item No. Spiral HSS (Optional)	180
Item No. Spiral Solid Carbide (Optional)	180C

Depth of Cut	0"	1/4"	1/2"	3/4"	13/16"
0"					
1/4"					
1/2"					
3/4"					
13/16"					

6-3 Joint layout Review the drawing below. **Symmetrical** joints have pins (A) on both edges of the pin board, and sockets (B) on both edges of the socket board. **Note: Only symmetrical joints can be routed on wider boards.** Asymmetrical joints are not possible on wide boards.

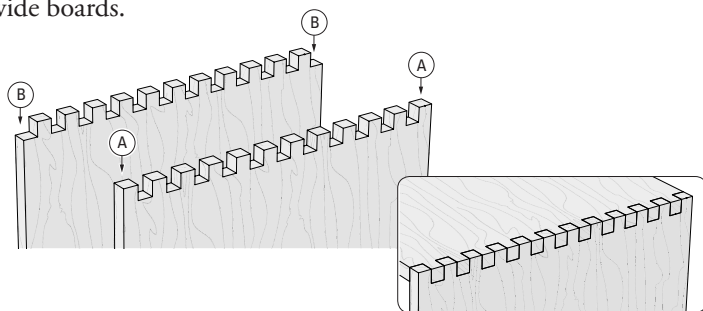

6-4 Board Width Selection Board widths are determined by the total number of pins and sockets in the joint design. Use this chart to choose your board width.

Board widths indicated in the chart below will produce full size pins and sockets at each board edge for symmetrical joints. Symmetrical joint board widths may be reduced as required, resulting in smaller but equally sized pins and sockets at each board edge.

Symmetrical Board Widths for 3/4" Box Joints on Wider Boards*											
Total Pins & Sockets	3	5	7	9	11	13	15	17	19	21	23
Inches	2 3/16"	3 11/16"	5 3/16"	6 11/16"	8 3/16"	9 11/16"	11 3/16"	12 11/16"	14 3/16"	15 11/16"	17 3/16"
Millimeters	56	94	132	170	208	246	284	322	360	398	437

Symmetrical Board Widths for 1/2" Box Joints on Wider Boards*																	
Total Pins & Sockets	3	5	7	9	11	13	15	17	19	21	23	25	27	29	31	33	35
Inches	1 7/16"	2 1/2"	3 1/2"	4 1/2"	5 9/16"	6 9/16"	7 5/8"	8 5/8"	9 5/8"	10 11/16"	11 11/16"	12 11/16"	13 3/4"	14 3/4"	15 3/4"	16 13/16"	17 13/16"
Millimeters	37	63	89	115	141	167	193	219	245	271	297	323	349	375	401	427	453

*Note: Wider boards are not possible when using a router table.

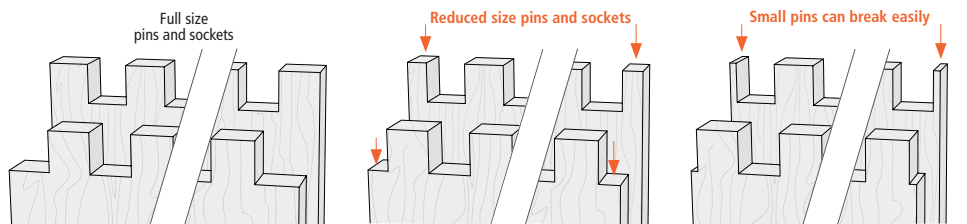

Width specified in the board width chart results in full size pins and sockets at each edge of the board.

When a symmetrical board width is reduced, the joint will have smaller, but equal sized pins and sockets at each edge of the board.

When the board width is reduced further, the result is very narrow and fragile pins at each edge of the board.

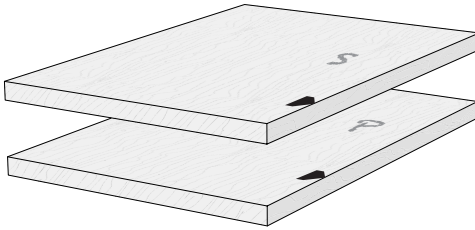

6-5 Wood Preparation In this example we are using boards with the following dimensions: 3/4" x 17-3/16" x 24" [19mm x 437mm x 203mm].

Mark the pin and socket boards and the board edge that goes against the side stop.

IMPORTANT: Read this whole chapter before routing any boards.

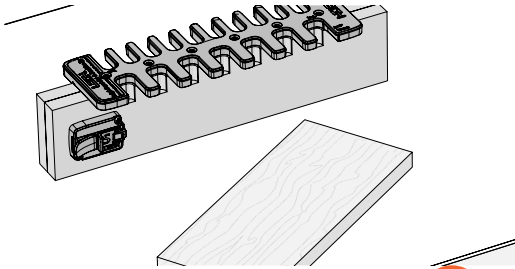

6-6 Boards wider than 9-11/16" [246mm] cannot be centered under the template. Therefore a narrower board must be used to position the side stop. Select a narrow board width from the chart and cut a board to that width, in this case, 3-11/16" [94mm].

Symmetrical Board Widths for 3/4" Box						
Pins & Sockets	3	5	7	9	11	1
inches	2 3/16"	3 11/16"	5 3/16"	6 11/16"	8 3/16"	9 11/16"
meters	56	94	132	170	208	246

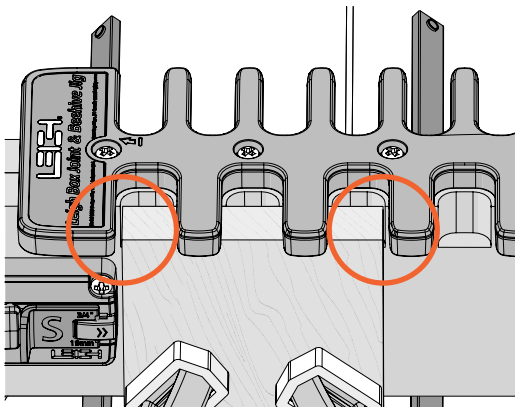

6-7 With the socket board stop fully retracted, clamp the narrow board in the vice and center the left end of the template over the board, leaving equal amounts of the board showing at each edge. Clamp the jig in place.

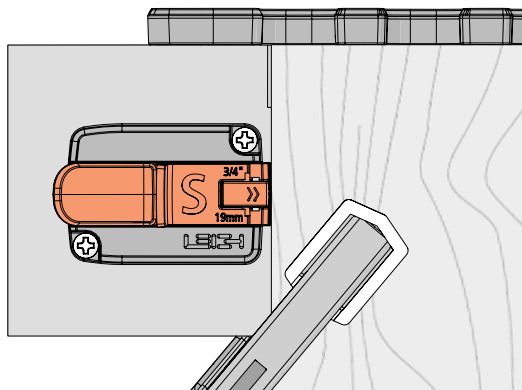

6-8 Slide the socket board stop until it touches the edge of the board and lock in place. The side stop is now set.

Remove the jig from the narrow board, and remove the board from the vice.

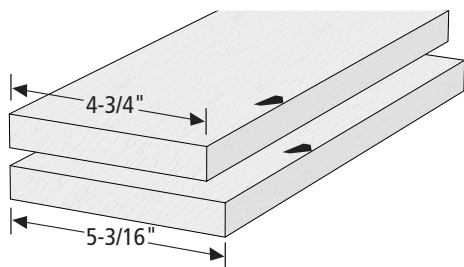

6-9 Boards Widths Less Than the Chart Width

For example: If the chart width is 17-3/16" [437mm] and your board width is 16-3/4" [425mm], the difference is 7/16" [11mm]. Select a narrow board width from the chart, in this case 5-3/16" [132mm], and reduce its width by the difference, 7/16" [11mm]. The narrower board width is now 4-3/4" [121mm]. Cut a board to that width and use the narrow board for step 6-7.

Symmetrical Board Widths for 3/4" Box

Pins & Sockets	3	5	7	9	11	1
inches	2 3/16"	3 11/16"	5 3/16"	6 11/16"	8 3/16"	9 11/16"
meters	56	94	132	170	208	246

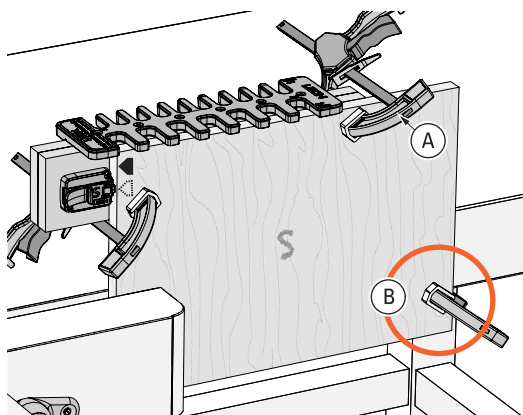

6-10 Routing the Socket Board

Clamp the wide socket board in the vice. Make sure the right hand clamp (A) will not interfere with the router. Wide and heavy boards should be secured with an extra clamp (B), or supported from the bottom.

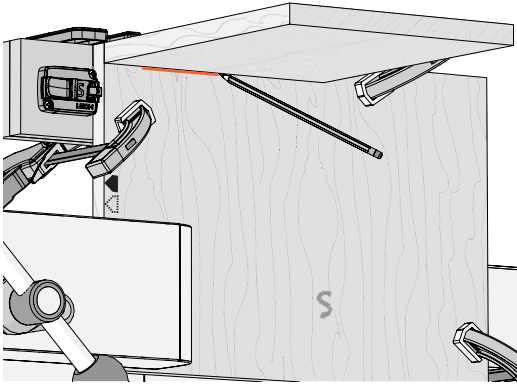

6-11 Set the depth of cut using a board the same thickness as the pin board, in this case $3/4"$. Holding the board flush under the template, draw a line on the socket board.

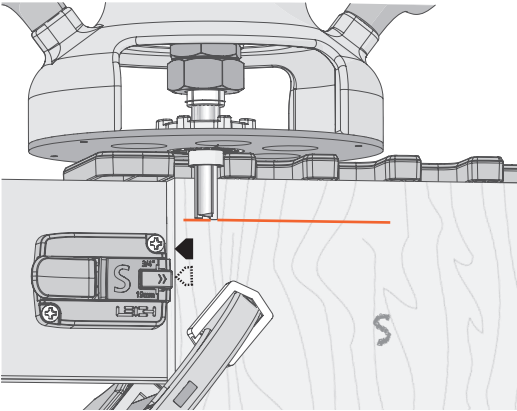

6-12 Place the router on the jig and adjust the tip of the bit up or down until it's at the center of the line. Rotate the bit and collet to ensure it spins freely and does not contact the eBush.

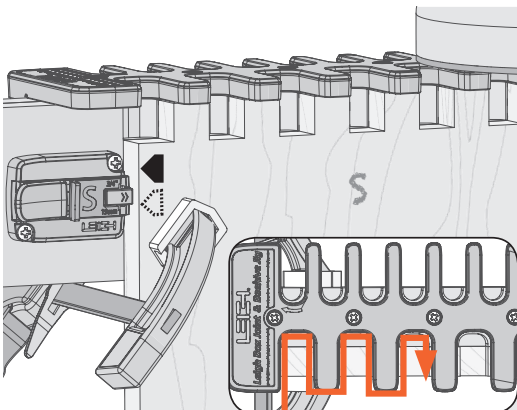

6-13 Now, hold the router firmly, as you rout straight in and out of all template openings.

Do not rotate the router.

Be sure the e10 touches the left side of the template opening on the way in, and the right side on the way out.

⚠ Do not remove the jig from the board.

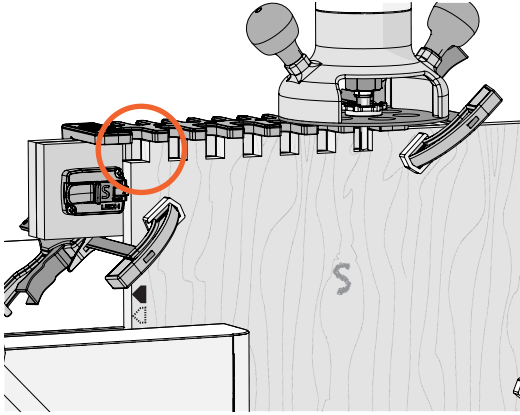

6-14 There will now be sockets on the left side of the board. The remaining part of the board is routed next, but first...

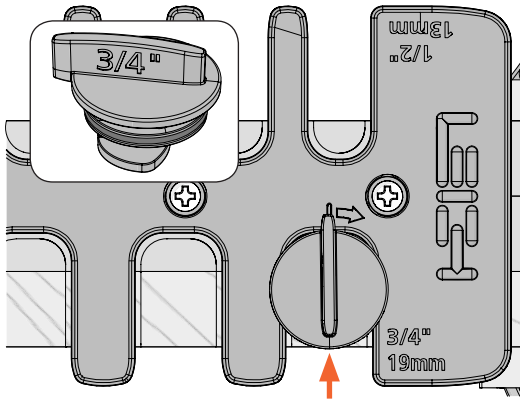

6-15 ...point the tip of the 3/4" cam to the back of the jig and insert it in the extreme right hand template opening.

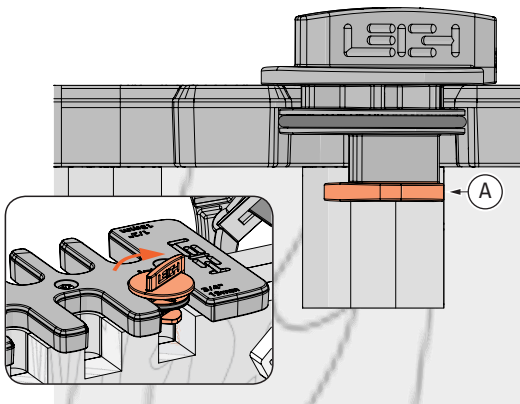

6-16 Turn the cam clockwise until the bottom part of the cam **A** touches the right side of the last routed opening of the board.

Leave the cam in place.

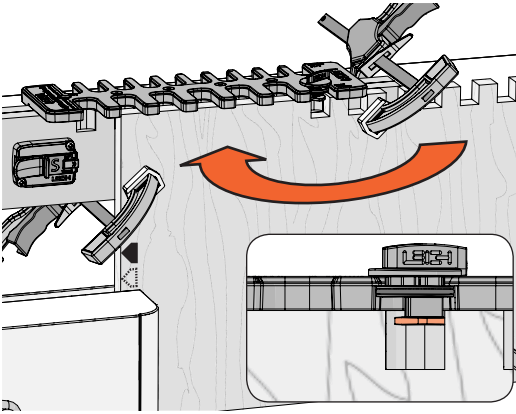

6-17 Unclamp the jig, flip the board horizontally, and re-clamp in the vice.

Position the jig on the board so the right edge of the cam just touches the inside right edge of the last routed opening. Clamp the jig in place making sure the right hand clamp will not interfere with the router. Remove the cam.

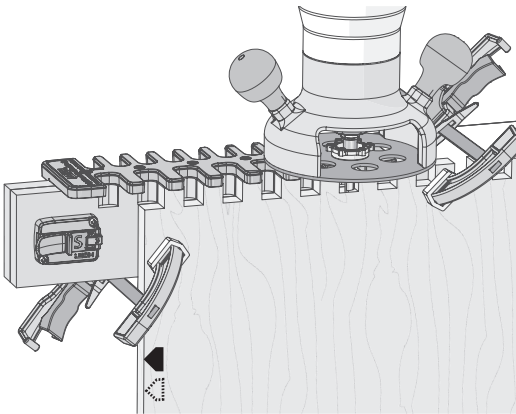

6-18 Rout the remaining part of the socket board. Remove the jig from the board and unclamp the board from the vice.

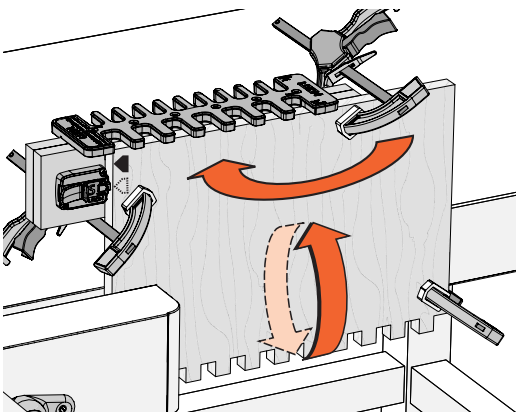

6-19 To rout the other end of the socket board, turn the board horizontally and flip it end for end, and re-clamp in the vice. Place the jig on the board with the side stop against the left board edge.

If you're making a box, rout a second socket board.

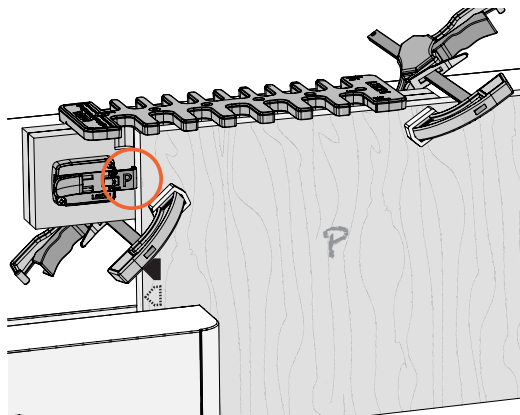

6-20 Routing the Pin Board

Flip the pin board stop to the **P** position. Place the jig on the board and slide it to the right until the left edge of the board touches the pin board stop. Clamp the board in place.

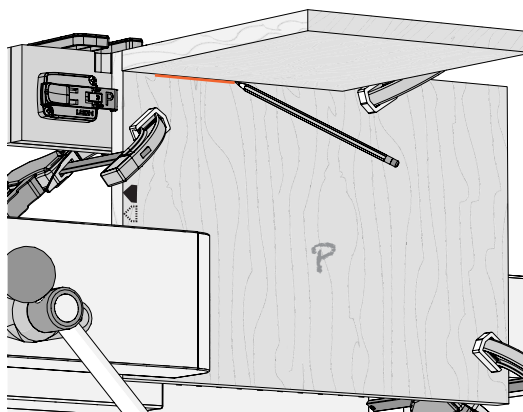

6-21 Socket and pin boards can be different thicknesses. Hold a board of the same thickness as the socket board, flush under the template, and draw a line on the socket board to indicate depth of cut.

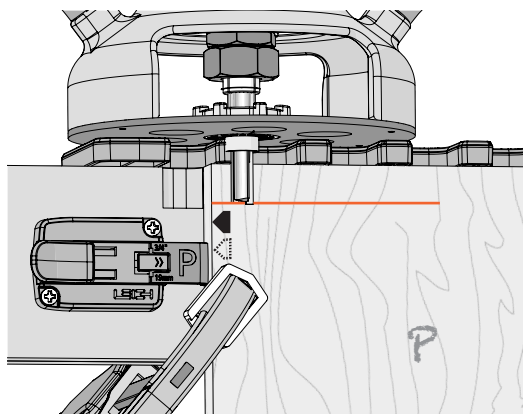

6-22 Place the router on the jig and adjust the tip of the bit up or down until it's at the center of the line. Rotate the bit and collet to ensure it spins freely and does not contact the eBush.

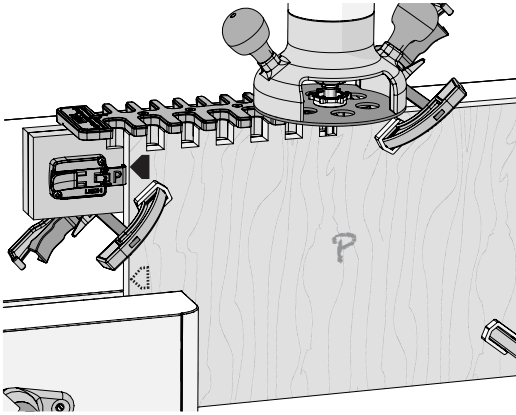

6-23 Now, hold the router firmly, as you rout straight in and out of each template opening. Be sure the e10 guide bushing touches the left side of the template opening on the way in, and the right side on the way out.

⚠ Do not remove the jig from the board.

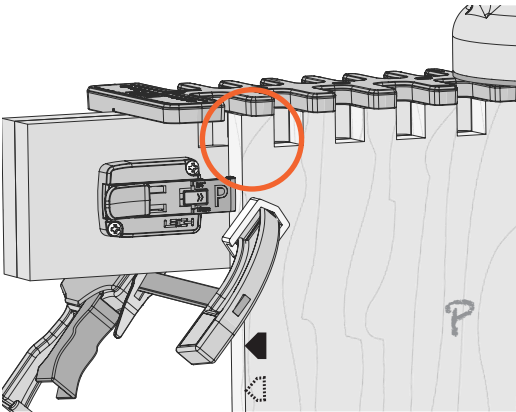

6-24 There will now be pins on the left side of the board. The remaining part of the board is routed next, but first...

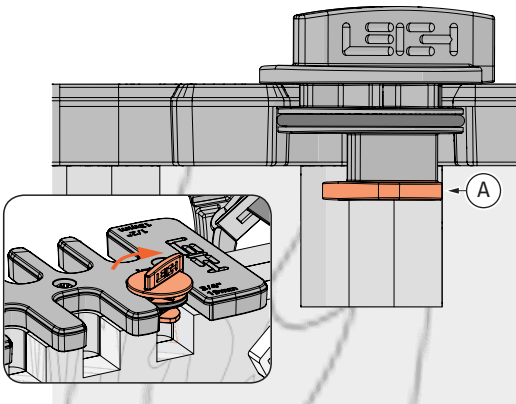

6-25 ...point the tip of the 3/4" cam to the back of the jig and insert it in the extreme right hand template opening.

Turn the cam clockwise until the bottom part of the cam **A** touches the right side of the last routed opening of the board.

Leave the cam in place.

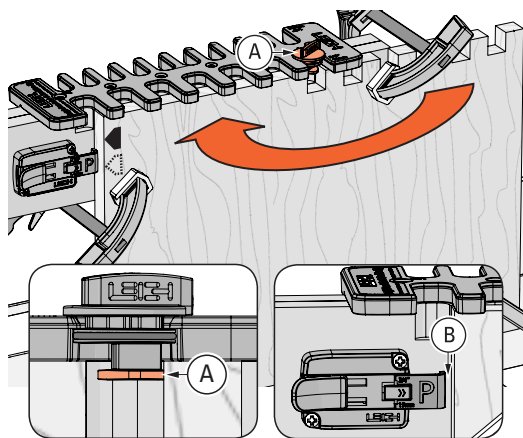

6-26 Unclamp and flip the board horizontally. Re-clamp in the vice.

The stepover cam (A), **not the side stop**, is used to position the jig on the board. There will be a small gap (B) between the side stop and the board. Place the jig on the board with the edge of the cam just touching the inside right edge (A) of the last routed opening of the pin board. Clamp the jig in place. Rout the rest of the pin board.

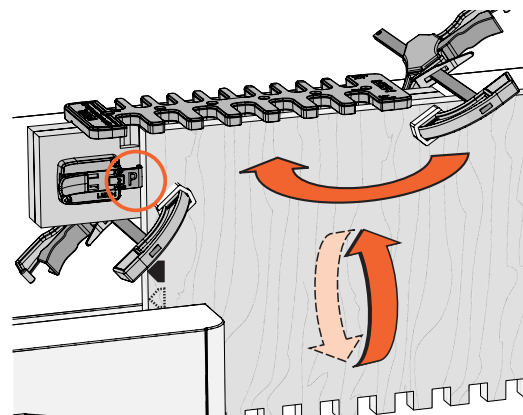

6-27 Remove the jig and unclamp the board from the vice.

To rout the other end of the pin board, turn the board horizontally and flip it end for end, and re-clamp. Place the jig on the board with the side stop against the left board edge.

If you're making a box, rout a second pin board.

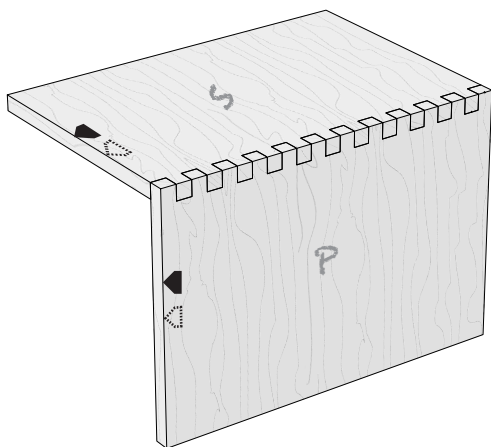

6-28 Assemble the joint, keeping the marked board edges aligned. ■

CHAPTER 7

Router Table Operation

This chapter assumes you have set up your jig following the Mounting & Assembly instructions in Chapter 4, Steps 4-17 to 4-22. You should also be familiar with all procedures in this user guide.

IMPORTANT SAFETY NOTE

Before using your Leigh B975, you must have completed the preparatory steps listed in the previous pages, including reading the jig safety recommendations in Chapter 2.

7-1 Getting Started The B975 can be used to rout box joints on a router table, on boards up to a maximum width of 9-11/16" [246mm]. This example uses 3/4" box joints on 3/4" thick boards. Procedures for routing 1/2" and 3/4" joints are identical.

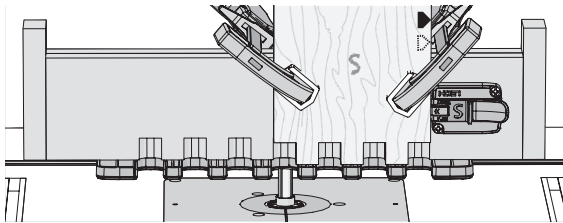

7-2 Parts Required 3/4" and 1/2" box joints are routed with the included Leigh No.160 1/2" straight bit and the Leigh e10 guide bushing (eBush). **No other bit diameter and guide bushing combination may be used.** Maximum board thickness for both joint sizes is 13/16" [20.6mm]. Depth of cut can be increased beyond the board thickness for raised joints. **Note:** Optional 1/2" diameter spiral upcut bits may also be used.

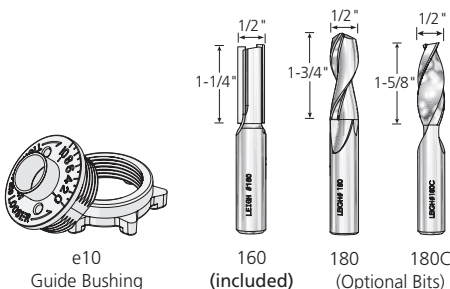

Bit Cutting Depth

Bit Diameter	1/2"
Item No. Carbide Tipped	160
Item No. Spiral HSS (Optional)	180
Item No. Spiral Solid Carbide (Optional)	180C

Depth of Cut	0"	1/4"	1/2"	3/4"	13/16"

7-3 Router Table Requirements Router tables are typically used with a bearing or fence, however, the Leigh B975 is guided around a guide bushing in the router table. Leigh eBushes (guide bushings) are designed around the 1-3/8" diameter industry standard. See specifications below.

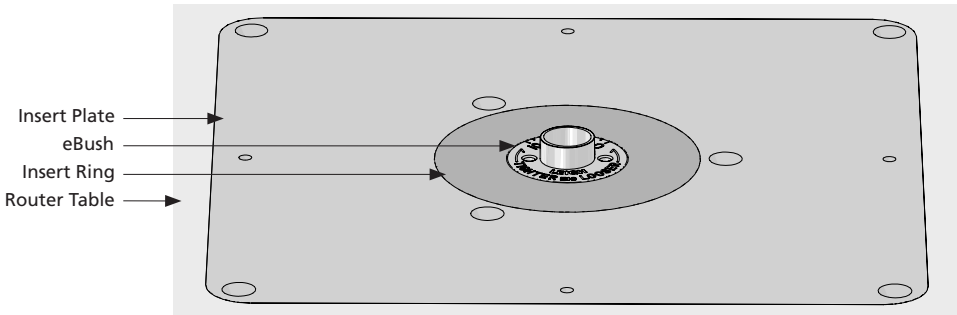
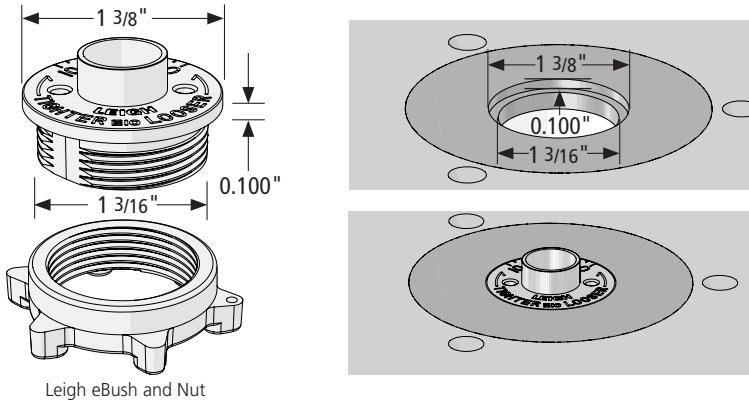

7-4 Insert Ring To install the eBush to your router table insert plate, you may need a 1-3/8" diameter counter bore insert ring. Check with your router table or insert plate (router lift) manufacturer, as to what adaptation, if any, is required.

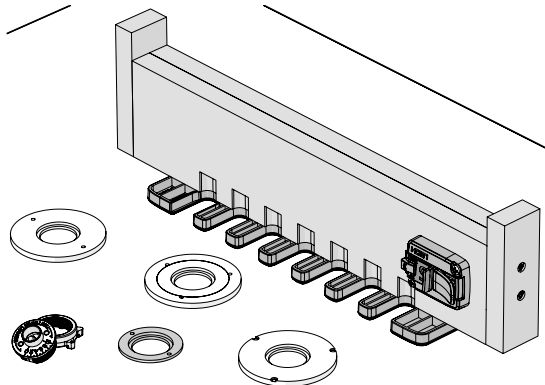

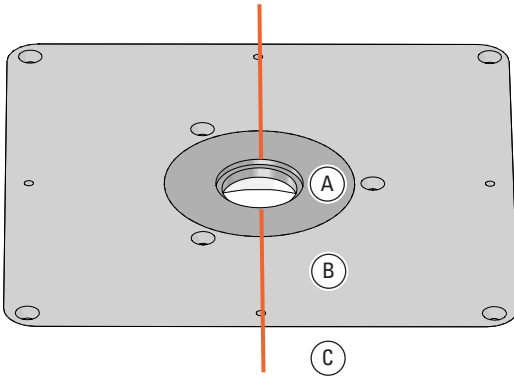

7-5 Draw a reference line with a permanent pen on the router table, centered on the guide bushing opening at 12 o'clock and 6 o'clock (shown in red for clarity only).

This will ensure correct orientation of the eBush to the insert ring **A**, the insert plate **B**, and the router table **C**.

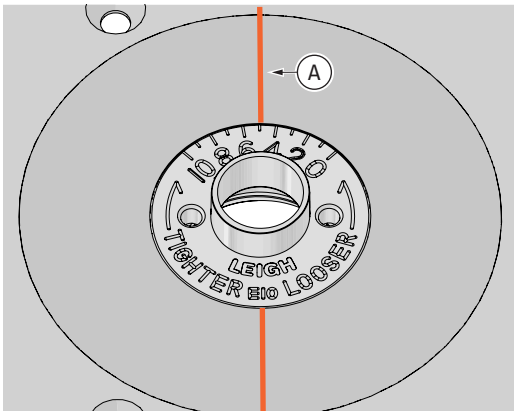

7-6 Install the e10 guide bushing in the router table. Turn the e10 to align the 5 position with the line **A** you've just drawn.

Using an initial setting of 5 allows adjustment for a looser or tighter joint fit. This line will also help you guide the jig.

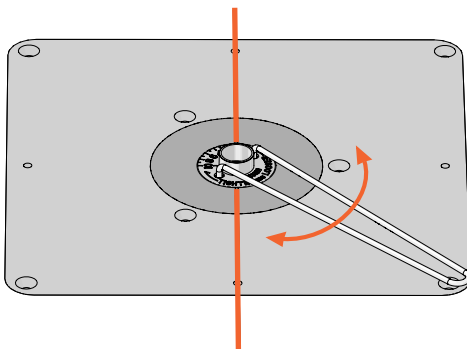

7-7 eBush adjustments are made with the included pin wrench. Markings on the eBush indicate which way to turn it for a looser or tighter fit. See Chapter 3.

Remember, every time you adjust the eBush you must re-tighten the eBush nut.

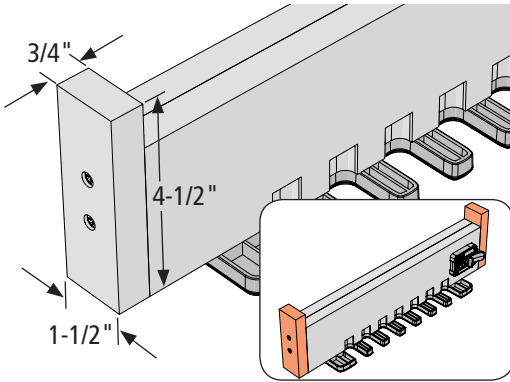

7-8 Before using the jig on a router table, handles must be attached to the ends of the beam. Cut two pieces of wood to the dimensions indicated and attach with screws.

The handles will keep your fingers safely away from the bit and help control the jig during routing.

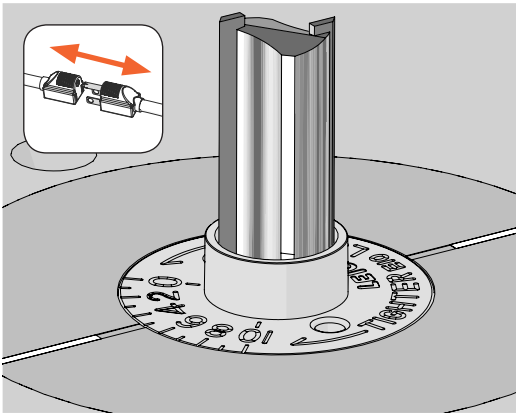

7-9 With the router unplugged, install the No. 160 straight bit to the router and tighten the collet nut.

⚠ Be sure the bit spins freely within the guide bushing before reconnecting the power.

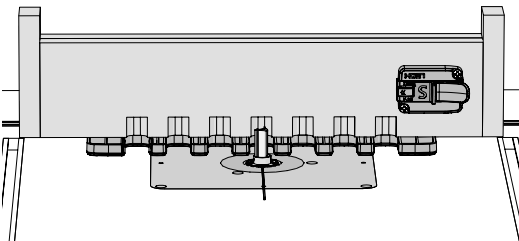

7-10 Reminder: If you haven't already done so, you must rout grooves on each side of the beam (see Chapter 4, steps 4-17 to 4-22).

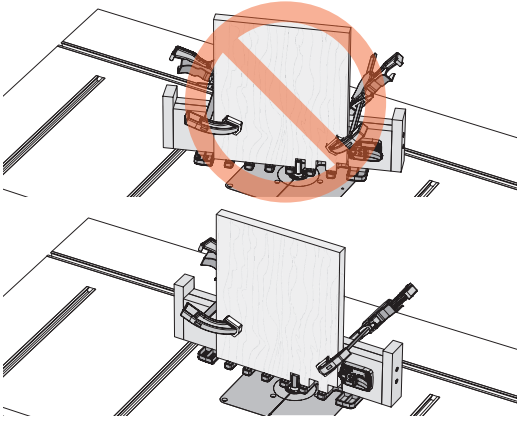

7-11 Do not turn or rotate the jig as you rout. Keep the jig parallel to the router table and go straight in and straight out of each template opening.

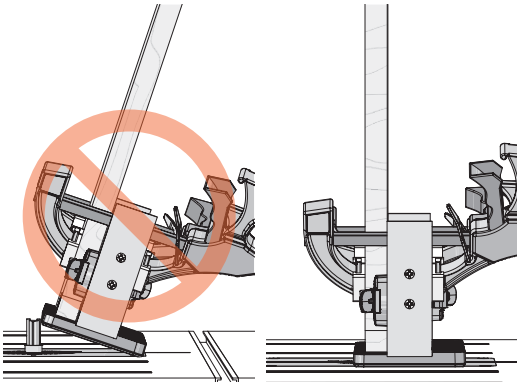

7-12 Never tilt the jig. Keep the jig flat on the router table at all times.

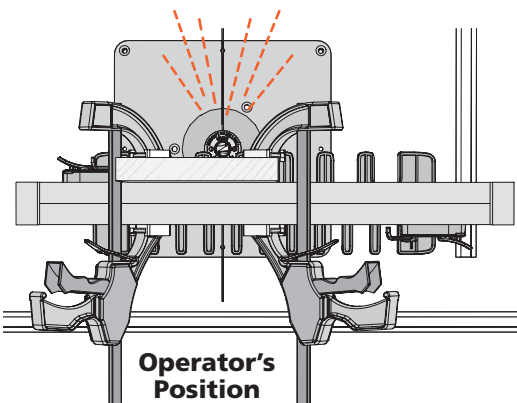

7-13 Chips and sawdust are thrown out at high speed. Always stand and use the jig away from chip and sawdust ejection.

7-14 Joint layout Symmetrical joints have pins (A) on both edges of the pin board, and sockets (B) on both edges of the socket board. Asymmetrical joints have a socket (C) on one edge and a pin (D) on the other edge of each board.

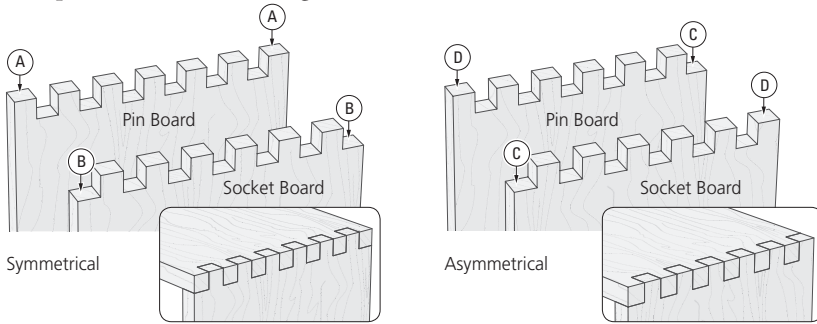

7-15 Board Width Selection Board widths are determined by the total number of pins and sockets in the joint design and whether the joint is symmetrical or asymmetrical. Use this chart to determine board widths up to 9-11/16" [246 mm].

Symmetrical Board Widths for 3/4" Box Joints

Total Pins & Sockets	3	5	7	9	11	13
Inches	2 3/16"	3 11/16"	5 3/16"	6 11/16"	8 3/16"	9 11/16"
Millimeters	56	94	132	170	208	246

Asymmetrical Board Widths for 3/4" Box Joints

Total Pins & Sockets	4	6	8	10	12
Inches	2 15/16"	4 7/16"	5 15/16"	7 7/16"	8 15/16"
Millimeters	75	113	151	189	227

Symmetrical Board Widths for 1/2" Box Joints

Total Pins & Sockets	3	5	7	9	11	13	15	17	19
Inches	1 7/16"	2 1/2"	3 1/2"	4 1/2"	5 9/16"	6 9/16"	7 5/8"	8 5/8"	9 5/8"
Millimeters	37	63	89	115	141	167	195	219	245

Asymmetrical Board Widths for 1/2" Box Joints

Total Pins & Sockets	4	6	8	10	12	14	16	18
Inches	1 15/16"	3"	4"	5 1/16"	6 1/16"	7 1/16"	8 1/8"	9 1/8"
Millimeters	50	76	102	128	154	180	206	232

7-16 Board widths indicated in the chart on the previous page will produce full size pins and sockets at each board edge, for symmetrical or asymmetrical joints. Symmetrical joint board widths may be reduced as required, resulting in smaller but equally sized pins and sockets at each board edge. If board widths are reduced for asymmetrical joints, one edge of the board will have a full size pin and socket while the other board edge will have a smaller pin and socket. This may result in an unattractive joint.

Symmetrical

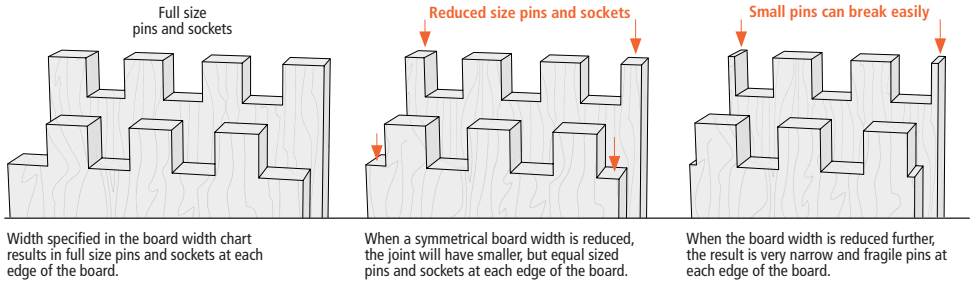

Asymmetrical

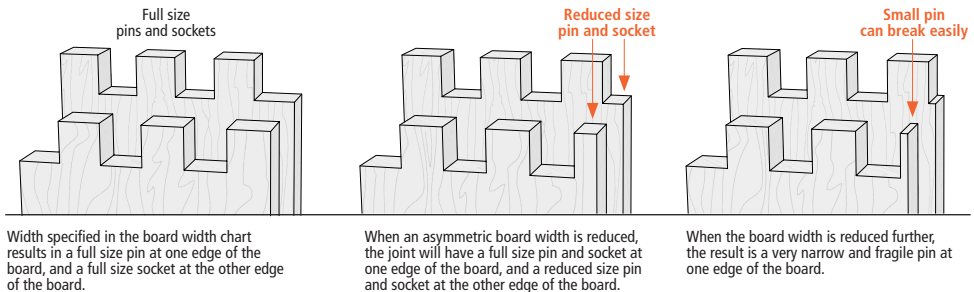

IMPORTANT: Read the whole chapter before routing any boards.

7-17 Making a Box

Prepare four similar boards $\frac{3}{4}$ " thick \times $5\text{-}\frac{3}{16}$ " wide by about 12" long [19mm \times 133mm \times 305mm], and two test boards, $\frac{3}{4}$ " thick by about 4" [100mm] wide.

Note: Boards of different thicknesses may also be joined.

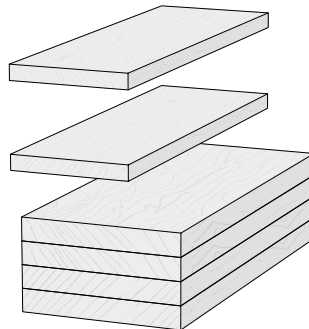

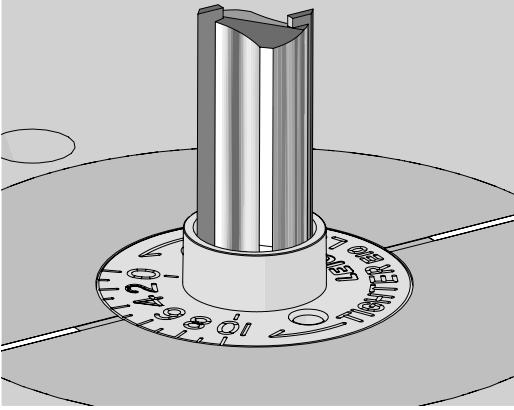

7-18 Routing a Test Joint Test joints are routed with the eBush set at the 5 position. Tighten the eBush nut after each guide bushing adjustment.

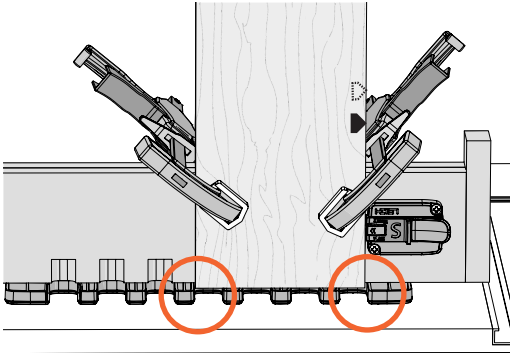

7-19 Center a test board on the left side of the 3/4" template, leaving an equal amount overhang on each edge of the board.

Clamp the board in place.

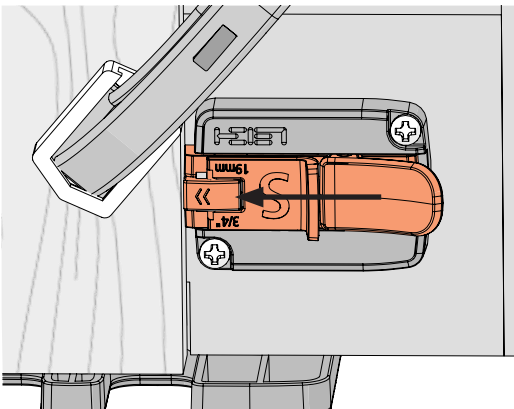

7-20 Slide the socket board stop until it touches the edge of the board. Secure the side stop with the thumb lock.

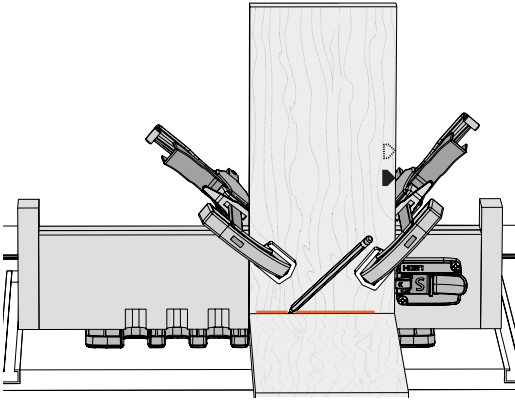

7-21 Socket and pin boards may differ in thickness. Always use the mating pin or socket board to determine the depth of cut. In this case, hold a pin board flush against the template and draw a line on the board, indicating depth of cut.

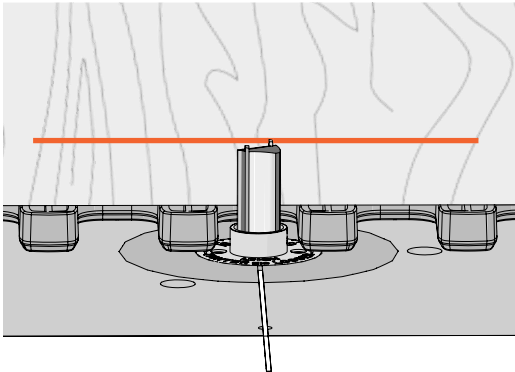

7-22 Place the router on the jig and adjust the tip of the bit up or down until it's at the center of the line. Rotate the bit and collet to ensure it spins freely and does not contact the eBush.

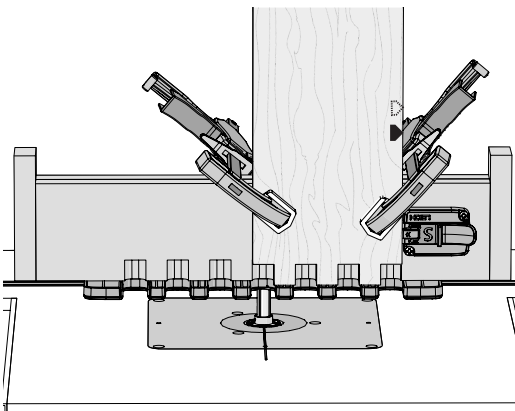

7-23 Rout straight in and out of each template opening. Be sure the e10 guide bushing touches the left side of each template opening on the way in, and the right side on the way out. **Do not rotate the jig.**

Chips and sawdust can accumulate between the template openings. Check each routed slot to ensure it has been routed completely. Remove the board.

7-24 Place the second test board against the side stop and clamp in place. Rout the board.

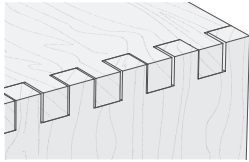
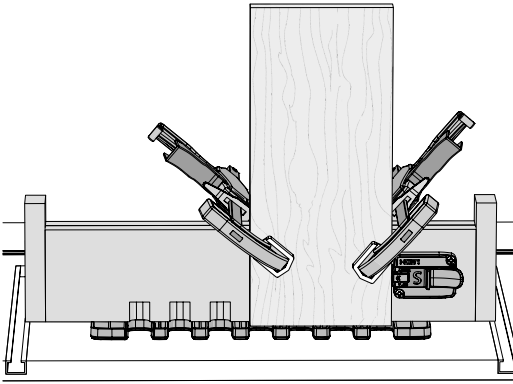

TOO LOOSE

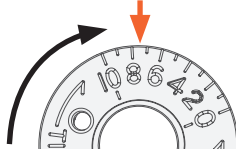

TIGHTEN

7-25 Joint Fit Adjustment

Assemble the test boards. If the joint is too loose, use the pin wrench and turn the eBush to a higher number and rout two fresh board ends.

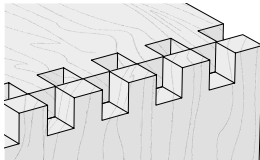

TOO TIGHT

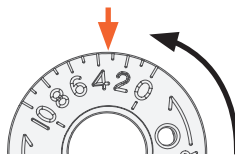

LOOSEN

If the joint is too tight, turn the eBush to a lower number and rout two fresh board ends.

Re-tighten the eBush nut after each guide bushing adjustment.

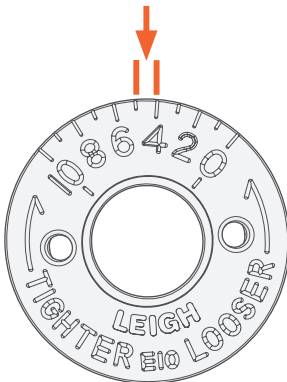

7-26 Each increment on the eBush changes the joint glue line fit by 0.002" [0.05mm]. Half an increment, a mere 0.001"!

SAMPLE

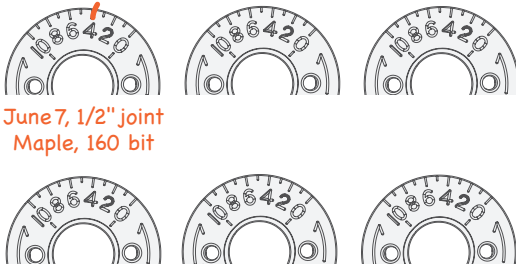

7-27 Use these eBush diagrams to record the settings you used to achieve perfect joint fit. The first eBush is an example of how to record your setting.

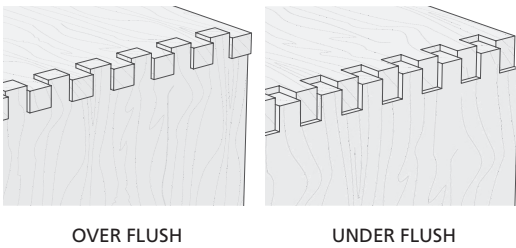

7-28 Joint flushness is determined by the depth of cut.

If the joint is over flush, lower the bit to make a shallower cut.

If the joint is under flush, raise the bit to make a deeper cut.

Rout new test joints until fit and flushness are perfect before routing the final boards.

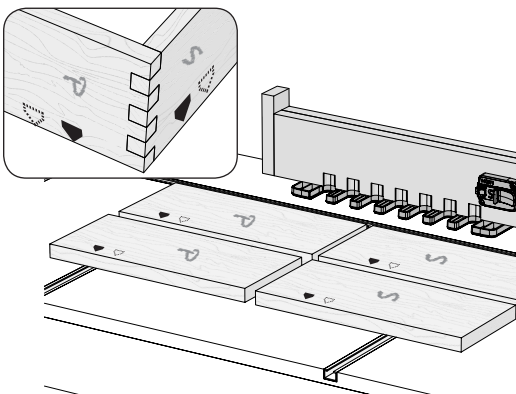

7-29 Making a Box

Lay out the four boards and mark two pin boards and two socket boards. Also, indicate the common board edges that will go against the side stop.

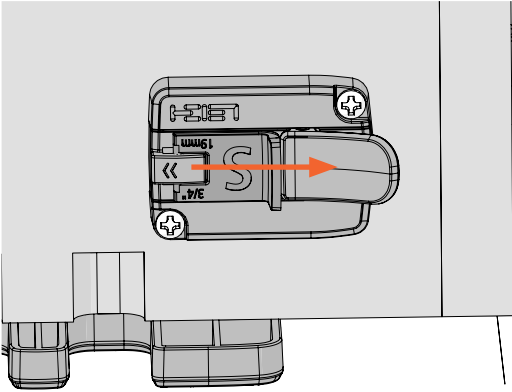

7-30 Before clamping the first socket board, ensure the socket board stop is fully retracted, and locked in place.

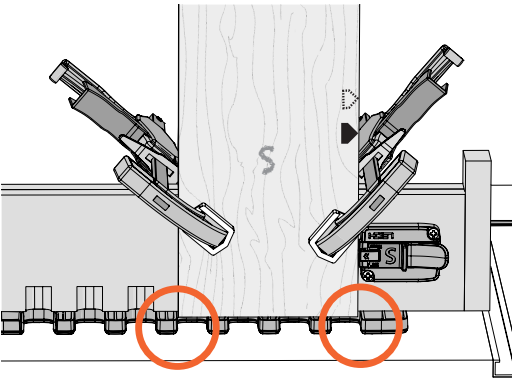

7-31 With the left edge of the board in the first template opening, position the socket board on the jig, leaving equal amounts of the board showing at each edge.

Clamp the jig in place.

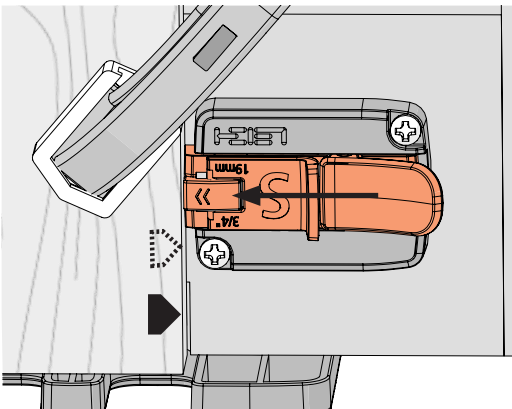

7-32 Slide the socket board stop until it touches the edge of the board, and secure with the thumb lock.

The side stop remains locked in place for all socket and pin board routing.

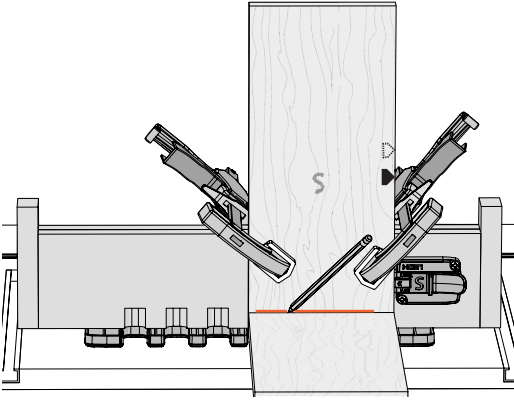

7-33 Hold a pin board flush against the template and draw a line on the board, indicating depth of cut.

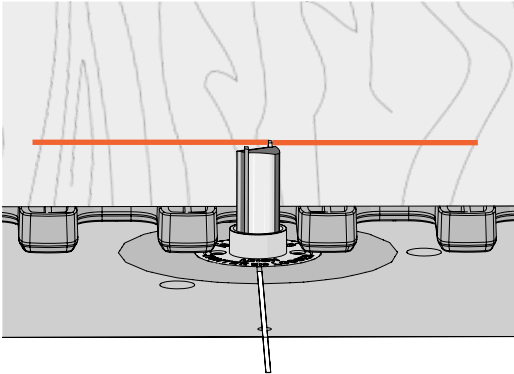

7-34 Adjust the tip of the bit up or down until it's at the center of the line.

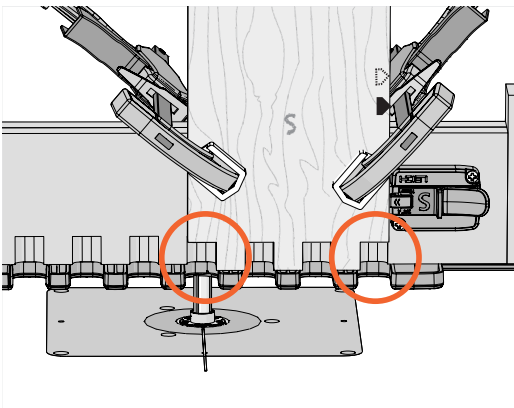

7-35 Rout straight in and out of each template opening. Be sure the e10 guide bushing touches the left side of the template opening on the way in, and the right side on the way out. **Do not rotate the jig.**

There will now be a full socket at each edge of the board.

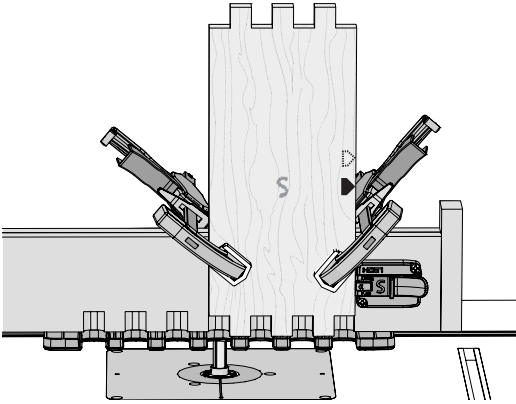

7-36 Unclamp and flip the first socket board end for end, keeping the same board edge against the side stop, and clamp in place. Rout in each template opening.

Repeat the procedure for the second socket board.

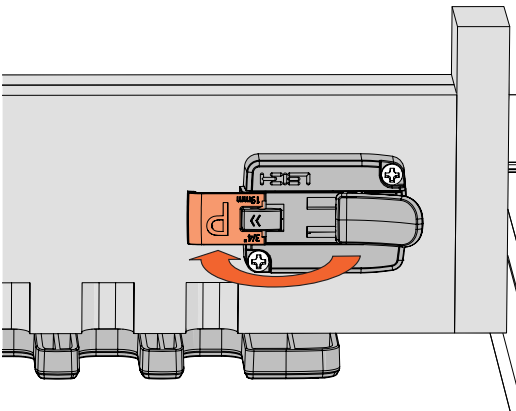

7-37 Routing the Pin Board

Flip the side stop to the pin board stop position.

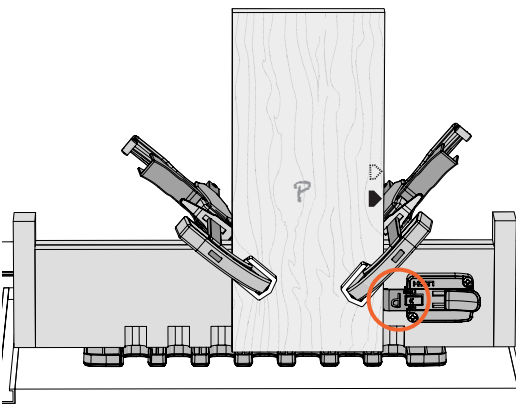

7-38 Place the first pin board on the jig with its edge touching the pin board stop and clamp in place.

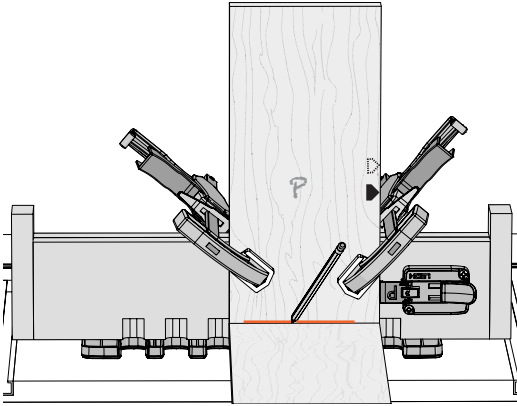

7-39 Hold a socket board flush against the template and draw a line on the board, indicating depth of cut.

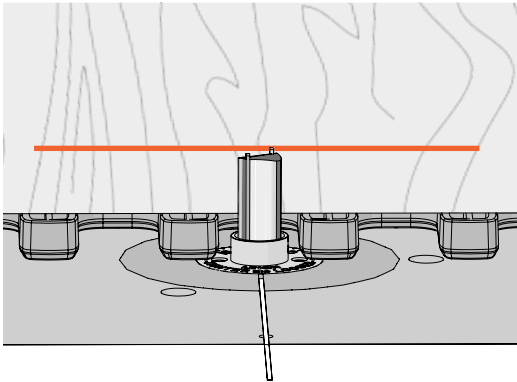

7-40 Adjust the tip of the bit up or down until it's at the center of the line.

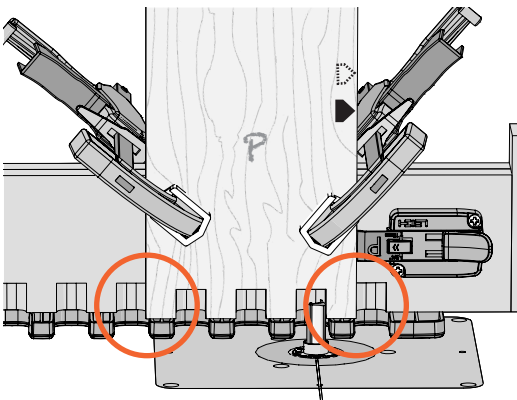

7-41 Rout straight in and out of each template opening. Be sure the $\epsilon 10$ touches the left side of the template opening on the way in, and the right side on the way out. **Do not rotate the jig.**

There will now be a full pin at each edge of the board.

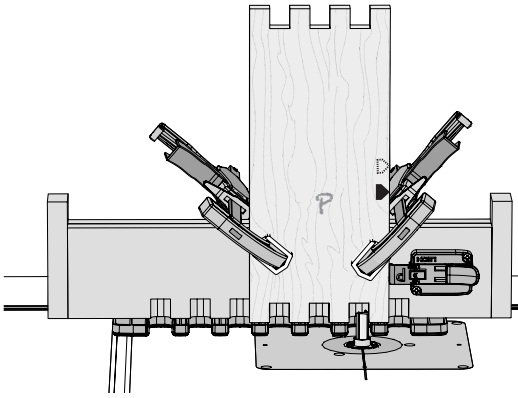

7-42 Unclamp and flip the first pin board end for end, keeping the same board edge against the side stop, and clamp in place. Rout in each template opening.

Repeat the procedure for the second pin board.

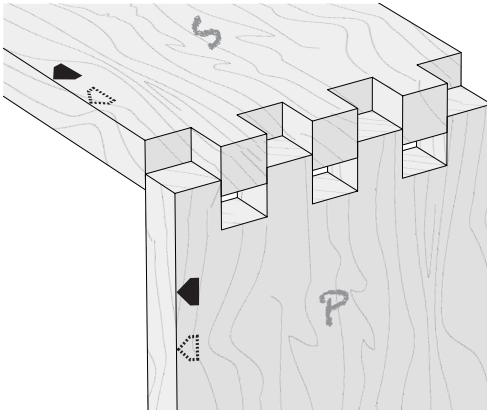

7-43 Remove the board from the jig and assemble the joint, keeping the marked board edges aligned. ■

B975 User Guide

CHAPTER 8 Guide Bushing Adapter Selection

FOR HAND HELD ROUTERS ONLY

The B975 requires a router fitted with the e10 guide bushing, and possibly an adapter to fit the bushing to the router. Leigh offers the following guide bushing adapters that fit many common routers.

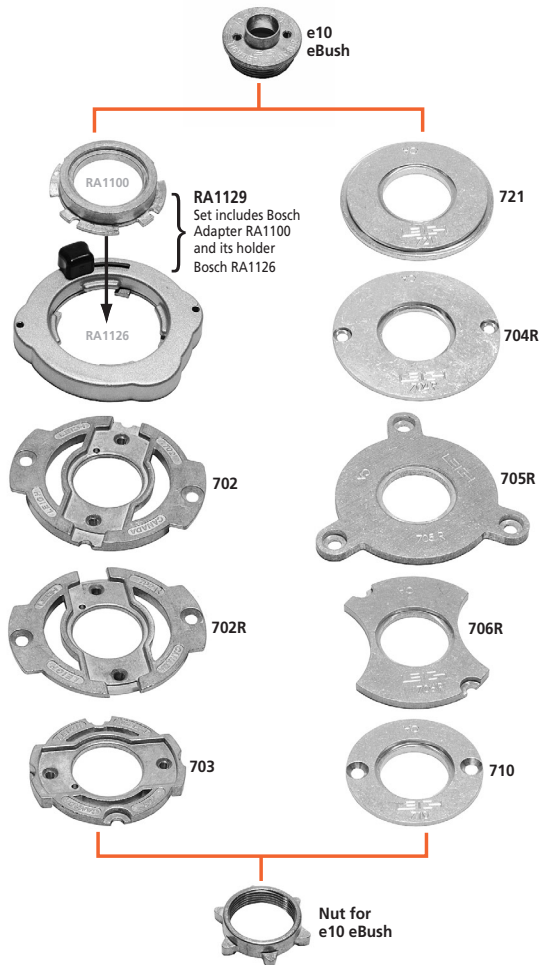

See the list of routers in the chart on the next page. **For a complete list of routers see www.leighjigs.com.**

DIRECTIONS

- A.** Locate router maker and router model in Columns 1 and 2.
B. Locate adapter required for your router in Column 3.
- Order Leigh adapters (part no's in red) in Column 3 from Leigh.
 - Order Bosch adapters RA1100 and RA1126 in Column 3 from Leigh or your Bosch dealer.
 - Order all other adapters from the router manufacturer's dealer.

Note: Adapter mounting screws are included with router.

- C. Note:** ♦ The e10 elliptical guide bushing (5/8" [15.8mm]) shown in column 4 is supplied with the B975 jig. Order only if you require a replacement.

Adapters for Router Tables

Leigh guide bushings and eBushes are based on the industry standard 1-3/8" 2-piece design. Most router tables have adapters that accept these standard guide bushings. If your router table does not have a suitable adapter, please check with the router table manufacturer.

1 BRAND	2 ROUTER MODEL	3 ROUTER ADAPTER	4 e10 ♦
BLACK & DECKER	All Professional, HD1250, RP400K, 7614	Not Required	e10
	6200	720673-00	e10
	SR100, 7AEE, KW780 series, KW800, KW850	710	e10
BOSCH	90085, 90088, 90098, 90140, 90150, 90300, 90303, 90305, 91264	Aftermarket base plate required	e10
	1600, 1601, 1602, 1603, 1604, 1606, B1350	RA1110	e10
	North American ROUTERS PRODUCED AFTER mid-2010: 1613EVS, 1613AEVS, 1617, 1617EVS, 1618, 1618EVS, 1619EVS, MR23EVS, MRC23EVS, MRF23EVS, MRP23EVS	RA1126 quick change adapter and RA1100 bushing adapter req'd	e10
	North American ROUTERS PRODUCED BEFORE mid-2010 and others available worldwide that include the RA1126 adapter: 1613(EVS)(AEVS), 1614(EVS), 1617EVS, 1618EVS, 1619EVS, B1450, GOF900(CE)(ACE), GOF1200, GOF1250(CE)(LCE), GOF1300(CE)(ACE), GOF1600CE, GOF2000CE, GMF1400, GMF1600CE, POF800ACE, POF1100AE, POF1200AE, POF1400ACE	RA1100	e10
	1611, 1611EVS, 1615, 1615EVS, B1550, GOF1600, GOF1700ACE	702	e10
CRAFTSMAN (SEARS)	All non-plunge models	Aftermarket base plate required	e10
	135275070 Plunge	See Skil 1823 or 1835	
	Other plunge models	702	e10
	MD11 Plunge & Fixed Base. MD9.5 Fixed Base	Not Required	e10
DEWALT	DW610, DW616, DW618	Not Required	e10
	DW613, DW615(UK)	710	e10
	DW614, DW615, DW621, DW624, DW625, DW626	N. America Only, Supplied w/router	e10
	DW621K, DW622 and DW626 outside N. America	706R	e10
	DW625 Type 1,2,3,5 outside N. America	702	e10
	DW624 & DW625 Type 4 outside N.America, DW625EK	702R	e10
FEIN	RT1800	Supplied w/router	e10
FESTOOL	OF1E, OF2E, OF650, OF900E, OF1000, OF1010E	704R	e10
	OF2000, OF2000E	705R	e10
	OF1400 and OF2200 North America Only	Supplied w/router	e10
	OF1400 Outside North America	493566	e10
	OF2200 Outside North America	494627 O-ring may be required to keep bushing centered	e10
FREUD	FT1700(2), FT2000, FT2200, FT3000	721	e10
HITACHI	TR8, TR12, FM8, M8, M12 Series	325211 OR 703	e10
	M12VC, KM12SC, KM12VC	Not Required	e10
	M12SA2, M12V2	325224	e10
MAKITA	M363, MRP090, RP1800(F), RP1801(F), RP2300(FC), RP2301(FC), 3612C Europe Qk Fit Base	721	e10
	3600, 3606, 3608, 3612, 3612B, 3612BR, 3612C N. America, 3620, 3621, RP0900, RP900K	703	e10
	3601B	321 493-1	e10
	RP0910, RP1110C	706R	e10
	RF1100, RF1101, RD1100, RD1101, RP1101	Not Required	e10
MASTERCRAFT	Please contact Leigh for assistance		
MILWAUKEE	5615, 5616, 5619	49-54-1040 (replacement base)	e10
	5625	49-54-1026 (replacement base)	e10
	5670	Not Required	e10
PORTER CABLE (ROCKWELL)	All	Not Required or Supplied w/router	e10
RIDGID	R2930 (for all others, please contact Leigh for assistance)	704R	e10
RYOBI	R30, R50, R150, R151, RE155, R500, R501, R502	703	e10
	R600, R601, RE600, RE601	702	e10
	R160, R161, R162, R163K, R165, R170, R175, RE175, R180, R180PL, R181, R185, ERT1150	706R	e10
	1823 or 1835	91803	e10
SKIL	SK1810, 1815, 1820, 1825	RAS140	e10
	All others	Aftermarket base plate required	e10
	T3, T4, T5, T9, T10, T11—UniBase required	710	e10
TREND	TRC001	TGA006 or 704R	e10
TRITON	JOF001, MOF001, TRA001	Accessory Kit (includes adapter) TGA001 or TGA150	e10

B975 USER GUIDE

CHAPTER 9 Customer Support

Our Commitment to You Leigh Industries takes pride in its commitment to providing excellence in customer service and support. This user guide is designed to provide you with the answers to any questions you have. However, if you require assistance, please feel free to contact customer service/technical support below or a distributor listed on the next page.

Manufacturer: Canada/USA

TEL/FAX

Customer Service and Technical Support

800-663-8932 (Canada/USA)

604-464-2700 (Tel.)

604 464-7404 (Fax.)

EMAIL/WEB

Customer Service

leigh@leighjigs.com

Technical Support

help@leighjigs.com

Website

www.leighjigs.com

NOTE: Email can be useful, but technical queries usually raise queries from us.

A phone call is the quickest and most convenient way to get queries answered, either directly to Leigh (toll free in North America) or to your national distributor.

–Thanks!

MAILING ADDRESS

Leigh Industries Ltd.

P.O. Box 357

Port Coquitlam, B.C.

Canada V3C 4K6

LOCATION

Leigh Industries Ltd.

1615 Industrial Ave.

Port Coquitlam, B.C.

Canada V3C 6M9

Distributors listed on next page.

Distributors**AUSTRALIA & NEW ZEALAND**

Maxis Distribution
128 Ingleston Rd., Wakerley, Qld., 4154
Australia

Tel: 1300 767 366
Tel (Int.): +61 7 3292 0392
Email: info@maxis.com.au
Web: www.maxis.com.au

CHINA

Harvey Industries Co., Ltd.
68-10 Suyuan Avenue
Jiangning District Nanjing 211100, China
Tel: (0)86 5792 8869 / 5792 8021
Fax: (0)86 5792 8826
Email: caozhi@harvey.cn
Website: www.harveyworks.cn

FRANCE

Ets Bordet
98 Rue Louis Ampère, 93330
Neuilly Sur Marne, France
Tel: 01 41 53 40 40
Email: info@bordet.fr
Web: www.bordet.fr

GERMANY, AUSTRIA & SWITZERLAND

Hacker GmbH
Holzbearbeitungsmaschinen
Traberhofstraße 103 D-83026 Rosenheim,
Deutschland
Tel: 08031 269650
Fax: 08031 68221
Email: hacker.rosenheim@t-online.de
Web: www.leigh.de

ITALY

Ferrari Macchine Legno SRL
Via Gallarata 74/76/78
20019 Settimo M.se (MI) Italy
Tel: 39 02 335 010 95
Fax: 39 02 335 005 27
Email: info@ferrarimacchine.com
Web: www.ferrarimacchine.com

JAPAN

Off Corporation Inc.
323-1 Yanbara, Shimizu-ku, Shizuoka-shi
Shizuoka-ken, Japan 424-0002
Tel: 81-50-3816-0115
Fax: 81-54-367-6515
Email: info@off.co.jp
Web: www.off.co.jp

KOREA

Leigh Korea
665-3, Munhyung-Ri, Opo-Eup, Kwangju-Si,
12774, South Korea
Tel: 82 (0) 70-8252-0988
Fax: 82 (0) 31-765-5602
Email: maengha@leigh.co.kr
Web: www.leigh.co.kr

**NETHERLANDS, BELGIUM
& LUXEMBOURG**

Houtbewerking Krielaart
9217RR Nijega, Netherlands
Tel: +31 512 354 770
Email: gerard@gkrielaart.nl
Web: www.leighjigs.nl

RUSSIA

Unicom Ltd.
Nikitskij Boulevard 12
Moscow, 119019, Russia
Tel: 7 (495) 690 0454
Email: info@leighjigs.ru (Russia)
Web: www.leighjigs.ru (Russia)

SOUTH AFRICA

Hardware Centre
PO Box 4059, Randburg 2125
South Africa
Tel: +27 011 791-0844/46
Fax: +27 011 791-0850
Email: info@hardwarecentre.co.za
Web: www.hardwarecentre.co.za

SWEDEN

Toolbox Sweden AB
Bruksgatan 3, S-597 30
Atvidaberg, Sweden
Tel: 46 120 854 50
Fax: 46 120 854 69
Email: info@toolbox.se
Web: www.toolbox.se

UNITED KINGDOM & IRELAND

Axminster Tools & Machinery
Headquarters, Unit 10, Weycroft Avenue
Axminster, Devon
EX13 5PH United Kingdom
Tel: 0800 371822
Text: 07786 200699
Email: cs@axminster.co.uk
Web: www.axminster.co.uk/leigh

5 Year Warranty

Leigh stands behind its products with a 5 year limited warranty. Contact Leigh for warranty service. Proof of purchase may be required. Postage is to be prepaid and insured to Leigh Industries Ltd. Return shipping is by means chosen by Leigh Industries Ltd.



Leigh Industries Ltd. warrants that this product is free of defects in factory workmanship and materials during normal use. If this product fails during normal use because of such a defect, Leigh Industries Ltd. will, at its option, repair or replace, free of charge, any part or parts shown to be so defective. This warranty applies to the original owner, who purchases for use and not for resale,

for a period of five years from the date of purchase. Failure resulting from alteration, modification, misuse, abuse or neglect or after repairs have been attempted or made by others will result in no coverage. The scope of this warranty is limited. This warranty constitutes the sole and exclusive remedy of the purchaser against Leigh Industries Ltd. from whatever cause, including without limitation, any cause relating to a breach of condition, representation or warranty, express or implied, whether by statute, common law or otherwise, or for damages for negligence or for any other claim for death, personal injury, property damage or economic loss of any kind, direct or consequential, arising out of the purchase, installation or use of this product. This warranty shall be governed by and construed in accordance with the laws in the Province of British Columbia, Canada which shall be deemed to be the proper law hereof.

Satisfaction Guarantee

Products purchased directly from Leigh carry a 90-day Customer Satisfaction Guarantee. Those purchased from an authorized Leigh dealer may also carry a Customer Satisfaction Guarantee; see your Leigh dealer for details. Proof of purchase is required.

Quick Reference B975 Board Width Selection

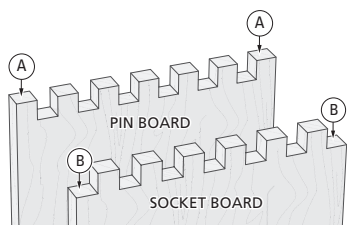

Symmetrical joints have pins **A** on both edges of the pin board, and sockets **B** on both edges of the socket board.

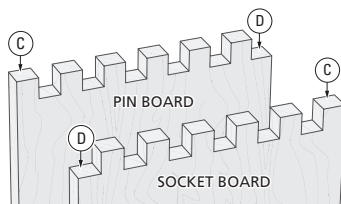

Asymmetrical joints have a pin **C** on one edge and a socket **D** on the other edge of each board.

Symmetrical Board Widths for 3/4" Box Joints

Total Pins & Sockets	3	5	7	9	11	13
Inches	2 3/16"	3 11/16"	5 3/16"	6 11/16"	8 3/16"	9 11/16"
Millimeters	56	94	132	170	208	246

Asymmetrical Board Widths for 3/4" Box Joints

Total Pins & Sockets	4	6	8	10	12
Inches	2 15/16"	4 7/16"	5 15/16"	7 7/16"	8 15/16"
Millimeters	75	113	151	189	227

Symmetrical Board Widths for 1/2" Box Joints

Total Pins & Sockets	3	5	7	9	11	13	15	17	19
Inches	1 7/16"	2 1/2"	3 1/2"	4 1/2"	5 9/16"	6 9/16"	7 5/8"	8 5/8"	9 5/8"
Millimeters	37	63	89	115	141	167	195	219	245

Asymmetrical Board Widths for 1/2" Box Joints

Total Pins & Sockets	4	6	8	10	12	14	16	18
Inches	1 15/16"	3"	4"	5 1/16"	6 1/16"	7 1/16"	8 1/8"	9 1/8"
Millimeters	50	76	102	128	154	180	206	232

Symmetrical Board Widths for 3/4" Box Joints on Wider Boards*

Total Pins & Sockets	3	5	7	9	11	13	15	17	19	21	23
Inches	2 3/16"	3 11/16"	5 3/16"	6 11/16"	8 3/16"	9 11/16"	11 3/16"	12 11/16"	14 3/16"	15 11/16"	17 3/16"
Millimeters	56	94	132	170	208	246	284	322	360	398	437

Symmetrical Board Widths for 1/2" Box Joints on Wider Boards*

Total Pins & Sockets	3	5	7	9	11	13	15	17	19	21	23	25	27	29	31	33	35
Inches	1 7/16"	2 1/2"	3 1/2"	4 1/2"	5 9/16"	6 9/16"	7 5/8"	8 5/8"	9 5/8"	10 11/16"	11 11/16"	12 11/16"	13 3/4"	14 3/4"	15 3/4"	16 13/16"	17 13/16"
Millimeters	37	63	89	115	141	167	193	219	245	271	297	323	349	375	401	427	453

*Note: Wider boards are not possible when using a router table.

