



F2, F1600 CHAPTER 10

Small Box Joints

These instructions are based on the assumption that you have mastered the routing of the basic box joint, and are thoroughly familiar with those procedures, and that you have read the Hints and Tips Chapter 11.

© Leigh Industries Ltd. All rights reserved.

The purpose of this publication is to assist in the use of products produced by Leigh Industries Ltd. The procedures described in this publication are suggestions only. The user shall determine risk and assume responsibility for personal safety practices and application suitability, and is solely responsible for any consequences of following these guidelines.

This pdf version of this publication is intended as suggested usage procedures and may be downloaded and stored on a computer and printed, viewed, and freely distributed for operational guidance and evaluation purposes. This pdf file may comprise a chapter or portion of the full User Guide publication for the Leigh tool and may refer to and depend on information in other parts of the tool's User Guide for completeness. Any such downloading, storage, printing, viewing or distribution must maintain the complete pdf file of the User Guide chapter in its entirety and in its original form as downloaded. Except as provided herein, no part of this document may be reproduced, sold, published, distributed, modified, displayed, re-posted or otherwise used without the prior written permission of Leigh Industries Ltd. [revision date]

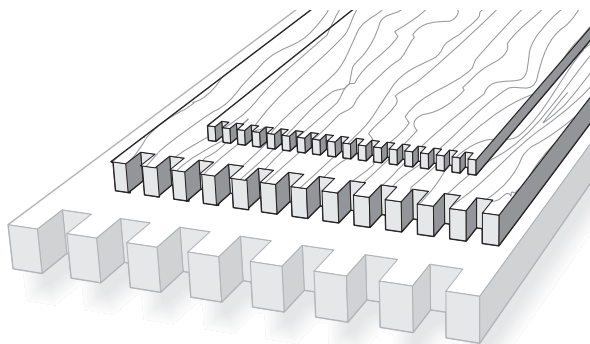

10-1 About Small Box Joints

The template pin positions for half and quarter size joints are clearly marked on the template. These allow routing of half-size, and even quarter-size box joints (but not rounded joints). You get the advantage of routing thicker, wider boards with for example, $\frac{1}{4}$ "[6mm] box joints on the $\frac{1}{2}$ "[12mm] template ... or as small as $\frac{1}{16}$ "[2mm] joints on the $\frac{1}{4}$ "[6mm] template.

To calculate board widths for small box joints, see page 68.

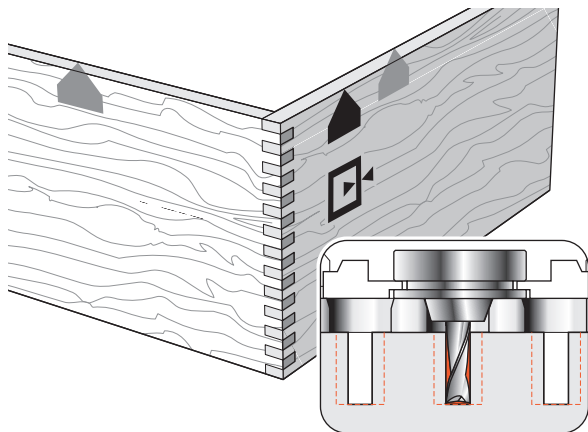

10-2 Routing Half-Size Joints

An example half size joint layout is $\frac{1}{4}$ "[6mm] joints on the $\frac{1}{2}$ "[12mm] comb. Use the same size guidebush for the selected comb, but use a cutter of half the nominal size. In this example, use the 716V bush with a $\frac{1}{4}$ "[6mm] cutter.

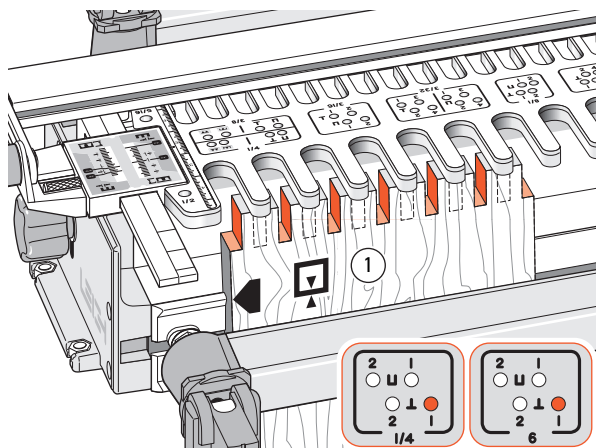

10-3

Clamp board ① in the jig against the side stop. Using the $\frac{1}{4}$ "[6mm] pin-hole panel (on the right-hand side of the template), place the template pin in the \blacktriangledown No.1 hole. Rout the half size $\frac{1}{4}$ "[6mm] sockets and leave the board ① in the clamp.

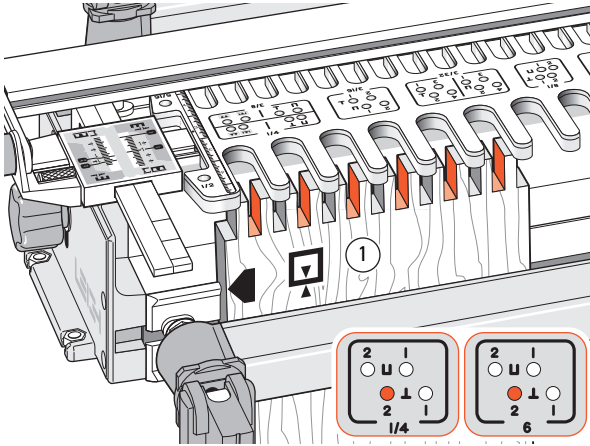

10-4

Move the template and put the template pin in the **↓** No.2 hole. Rout the rest of the half size sockets and remove the board. This board ① will now have fingers and sockets half the nominal size.

Repeat instructions 3 and 4 on the other end of board ①, and on both ends of board ③, making sure at each step to keep the same side edge against the side stop.

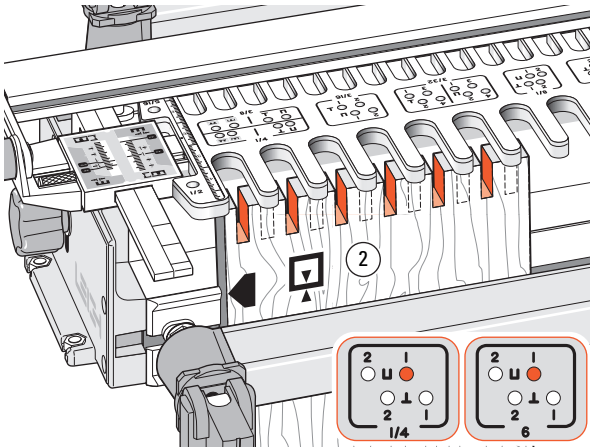

10-5

Mount the mating board ②. Put the template pin in the **U** No.1 hole. Rout the first set of sockets and leave the board in the clamp.

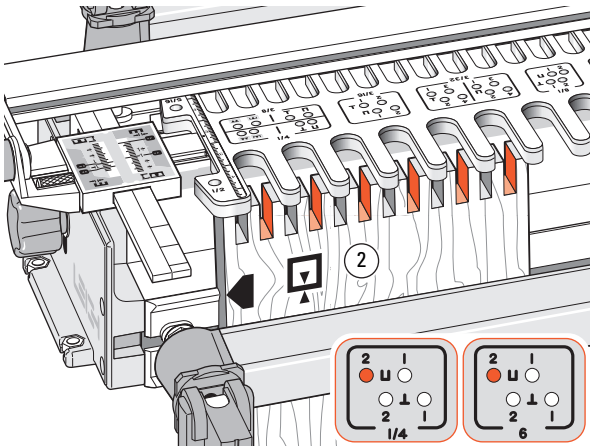

10-6

Move the template and put the template pin in the **U** No.2 hole. Rout the remaining half size sockets and remove the board.

Repeat instructions 5 and 6 on the other end of board ②, and on both ends of board ④, again making sure to keep the same board side edge against the side stop.

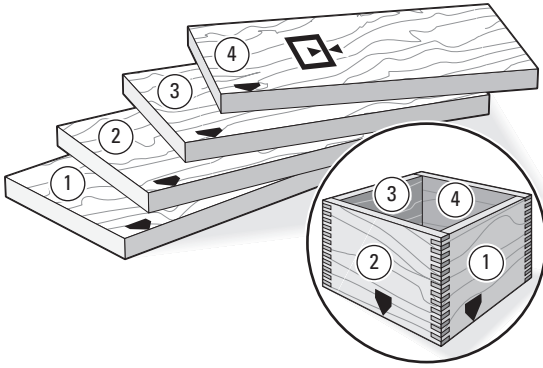

10-7

During assembly of the box, always keep the side stop edges of the boards either to the top, or bottom of the box.

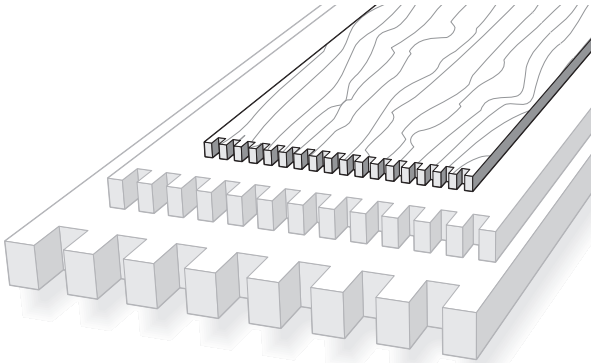

10-8 Quarter Size Joints

An example quarter size joint layout is 1/16" [2mm] joints on the 1/4" [8mm] comb.

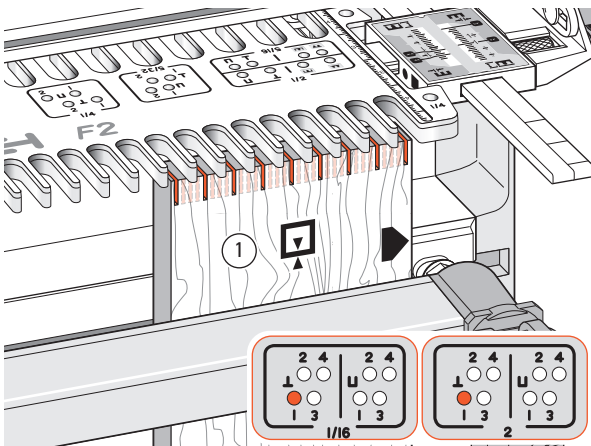

10-9

Clamp board ① in the jig against the right-hand side stop. Using the 1/16" [2mm] pin-hole panel, place the template pin in the ↓ No. 1 hole and rout the quarter size 1/16" [2mm] sockets. Leave the board in the clamp.

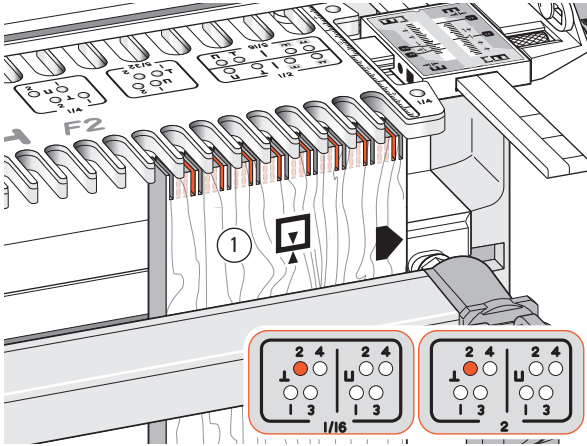

10-10

Move the template and put the template pin in the **⬇** No.2 hole and rout again.

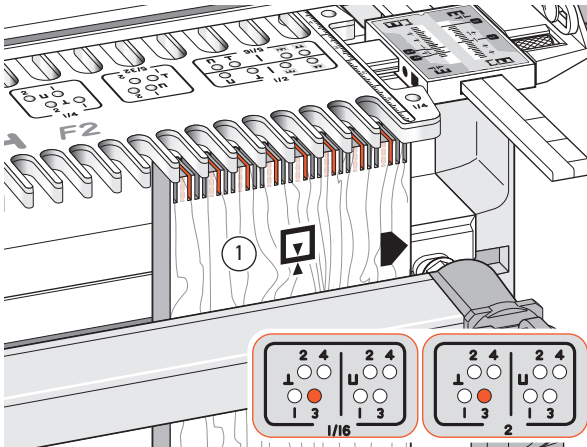

10-11

Move the template and put the template pin in the **⬇** No.3 hole and rout again.

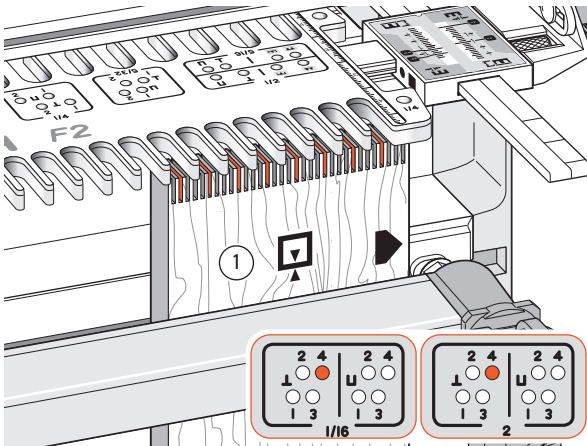

10-12

Last, move the template and put the template pin in the **⬇** No.4 hole. Rout the last sockets and **remove the board**.

Repeat instructions 9 through 12 on the other end of board ①, and on both ends of board ③, making sure at each step to keep the same side edge against the side stop.

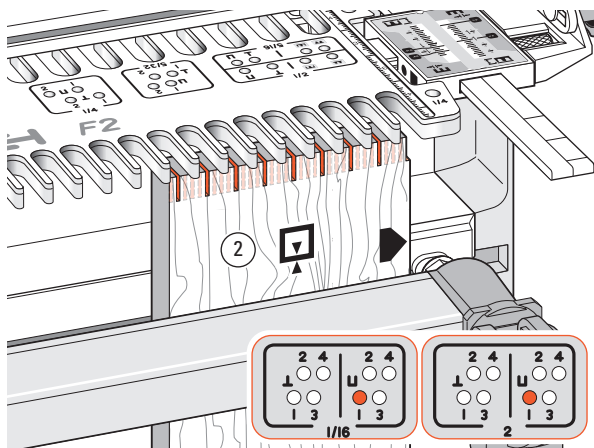
**10-13**

Mount the mating board ②. Put the template pin in the **U** No.1 hole and rout the first set of sockets. Leave the board in the clamp.

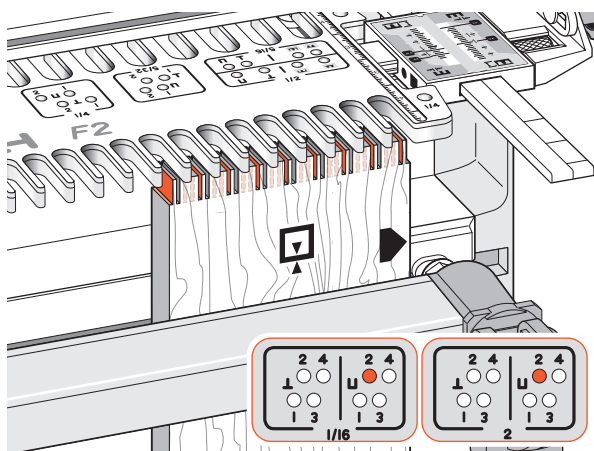
**10-14**

Move the template and put the pin in the **U** No.2 hole. Rout the second set of sockets.

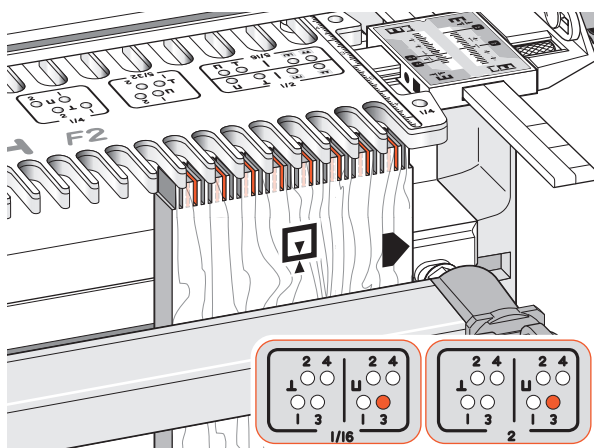
**10-15**

Rout again in pin position **U** No.3.

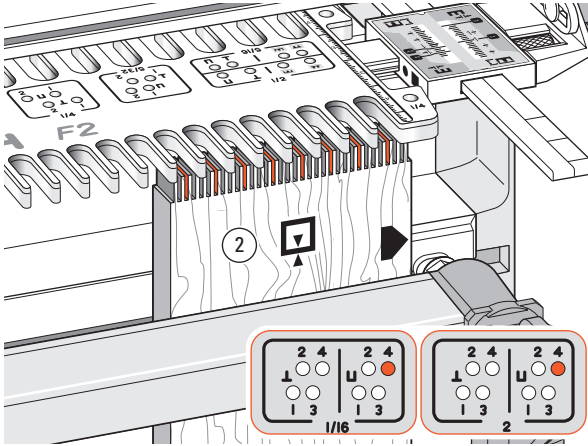

10-16

Then rout in pin position **U** No.4.

Repeat instructions 13 through 16 on the other end of board **2**, and on both ends of board **4** making sure at each step to keep the same side edge against the side stop.

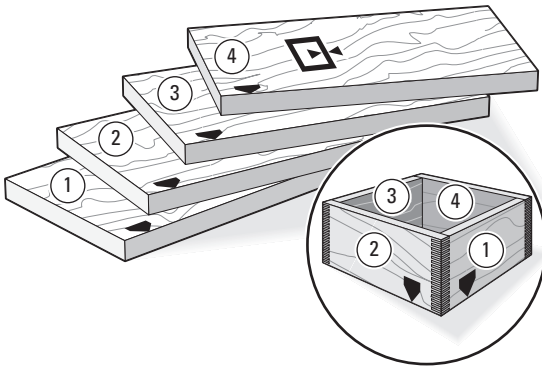

10-17

During assembly of the box, always keep the side stop edges of the boards either to the top or bottom of the box.

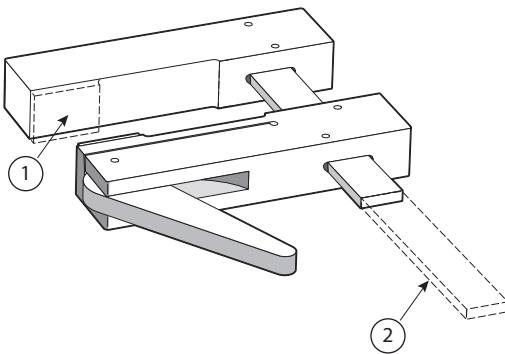

10-18 A Fixture for Routing Multiple Pieces

For very thin or short boards, make up an auxiliary clamp with its own *stepped* side stop by adapting a stock clamp. Remove the grip pad **1** flush to the fixed jaw face. Remove the excess metal bar **2**. These useful wooden clamps are generally available from most good woodworking tool stores.

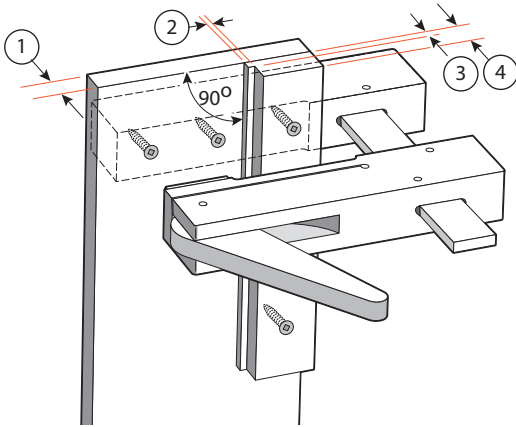
**10-19**

With this shop made fixture you can rout up to four pieces at once and speed up small box joint production. You will need to adjust the scale settings to allow for the backboard thickness, e.g. a $\frac{1}{2}$ " [12mm] backboard ① will require moving the template $\frac{1}{2}$ " [12mm] further toward you. Number ② is a step, equal in width to the small cutter diameter used. The step depth ③ is slightly less than one, or two board thicknesses, depending on whether two or four pieces are being routed at one time. The overall side stop depth ④ is greater than all board thicknesses combined.

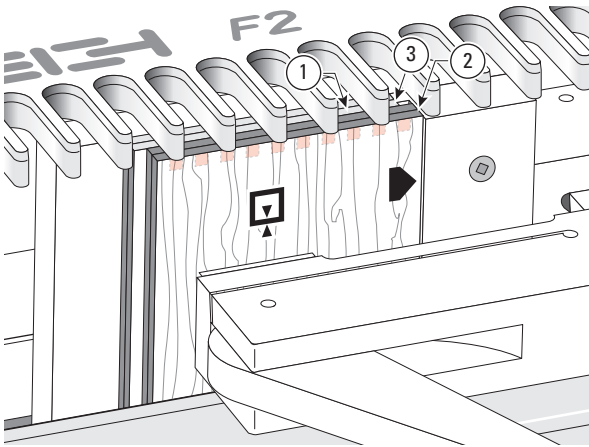
**10-20**

The front jig clamp holds the auxiliary clamp by its stepped side stop. The small boards may slide behind the jig front clamp bar if necessary. The rear two boards ① are offset from the front two boards ② by the stepped side stop ③, at an amount equal to the **small cutter diameter used**.

Adjust the auxiliary clamp left and right in the jigs front clamp to allow for the correct side edge finish.

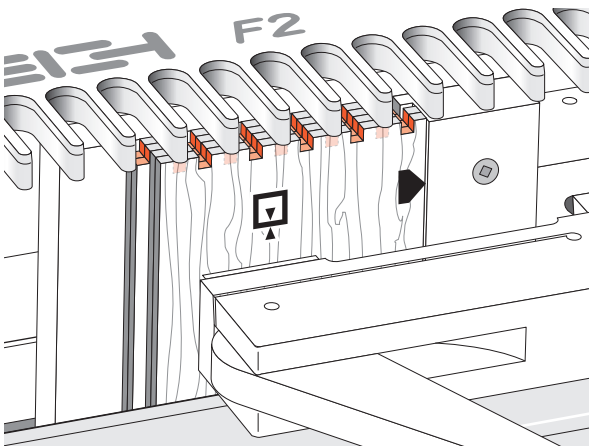
**10-21**

In this example, a half-size joint is being simultaneously routed in all four box board ends. First in one pin position...

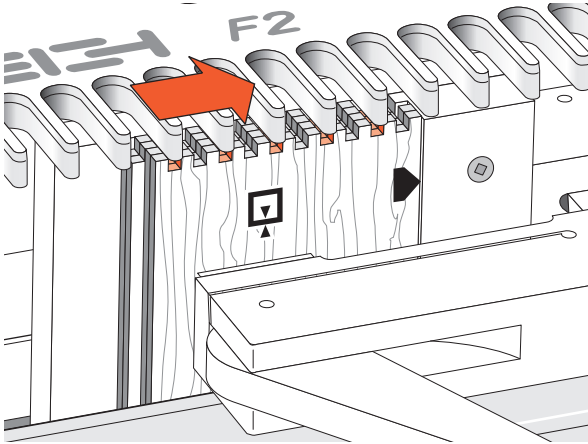

10-22

...then in the next.

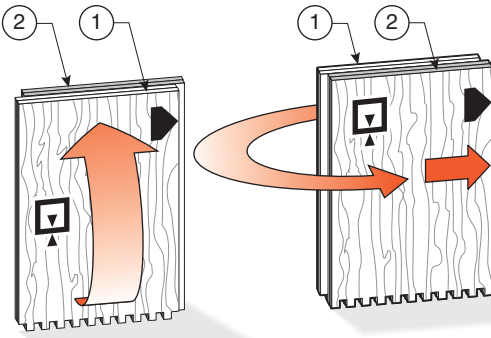

10-23

Remove all four boards together, and turn end for end, keeping the same edges to the side stop. Move boards ② back to the front before re-clamping.

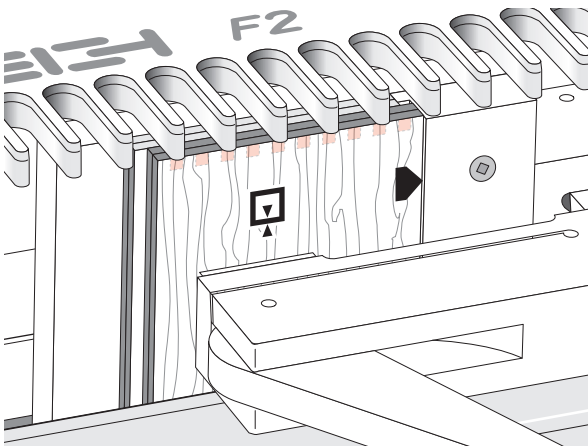

10-24

Now rout these four ends in the same two template pin positions as before.

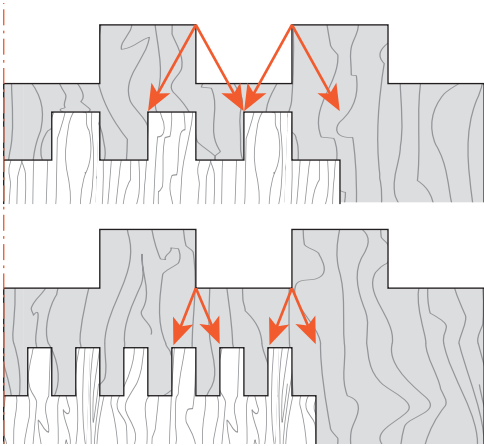

10-25 Board Widths for Small Box Joints
Small joint board widths are calculated from the board width charts on pages 32 and 33.

All Symmetrical Joints

Use chart width plus or minus the diameter of the small cutter used.

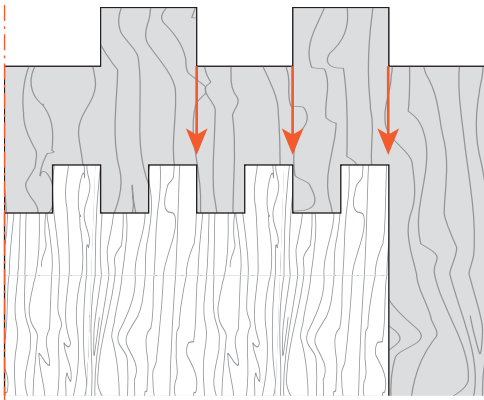

10-26

Asymmetrical Joints, Half Size

Width as per chart.

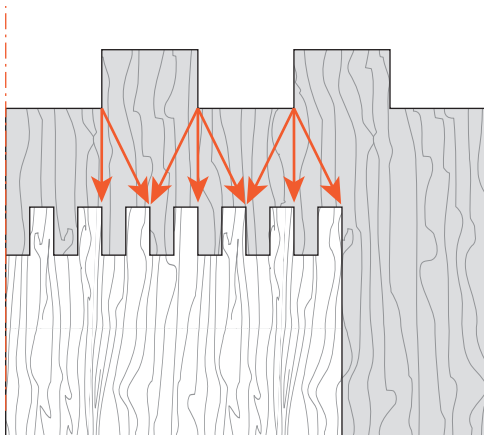

10-27

Asymmetrical Joints, Quarter Size

Chart width plus or minus 2 diameters of the small cutter used. ■



F2, F1600 **CHAPTER 11**

Hints and Tips

Here are some special techniques and ideas to help you get the most out of your Leigh Finger Joint Template.

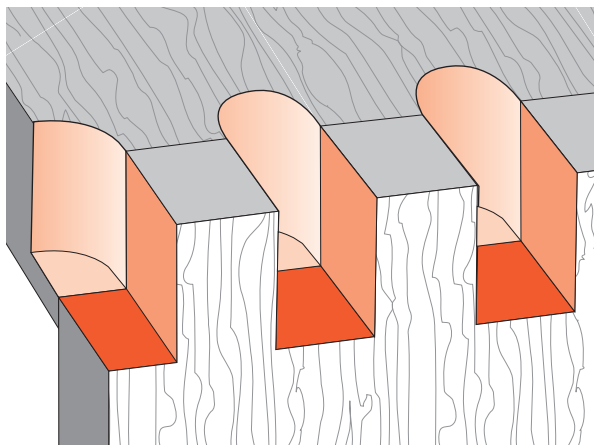
**11-1**

To help prevent tear-out on the sides and bottom of the exit cut, back up the cut with a horizontal board end-grain pushed against the back of the workpiece and held in the rear clamp.

This same scrap piece can remain in place for successive cuts.

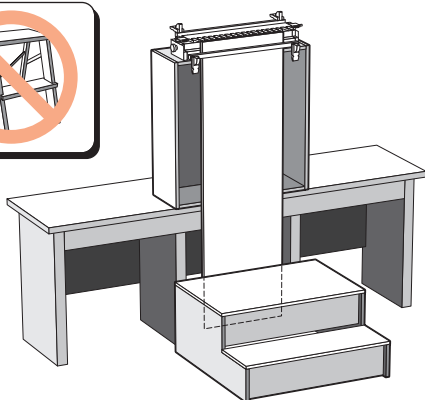
**11-2**

For routing long vertical boards it may be necessary to build a jig stand to mount securely on your bench. Make the stand and bench height combination sufficient to accept the board length you have in mind. The jig stand should be bolted securely to the bench. Make up a stable platform to stand on as in the illustration. Do not use a set of steps. Steps are not stable enough.

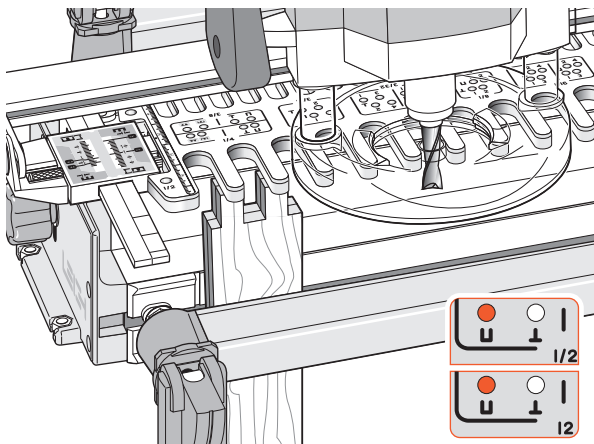
**11-3 Quick Fit Test**

Rather than routing test pieces separately, here is a quick way to get 99% of the way there. Simply rout two thinner boards of scrap stock simultaneously. Any single pin position will do, unless you intend to rout small box joints, in which case, use the matching pin positions described in chapter 10.

If you prefer, use one piece and saw in half after routing.

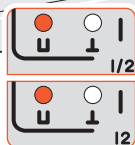

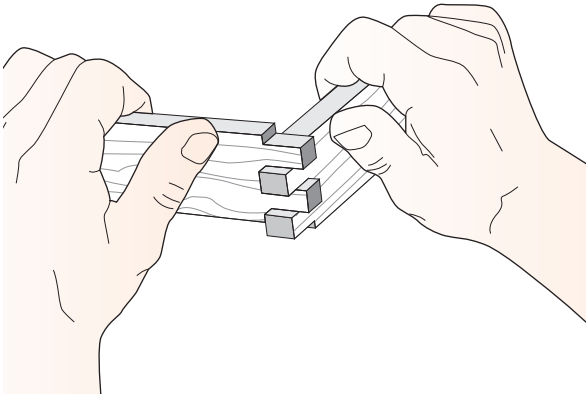

11-4

Test for fit. Don't worry about board alignment, it's only the fit you're testing. Adjust the VGS by trial and error and rout more pairs of scrap board ends as required. Once you have a good fit, rout a complete pair of separate test pieces in the same species wood as the actual workpieces, to test for final fit.

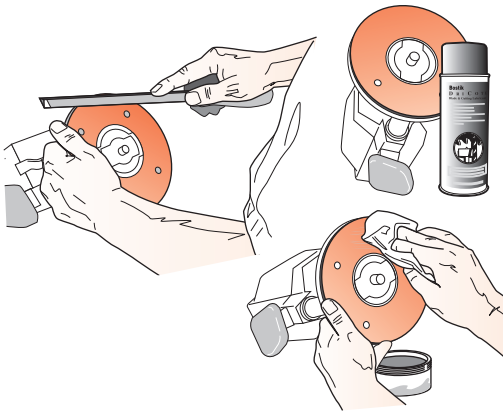

11-5

Some router bases have sharp edges on the outside and inside corners. A slight chamfer of the edges with a fine file or sandpaper block will ease router movement on the jig. An occasional light spray of TopCote® or application of soft wax to the router base makes for smooth, easy router movement on the jig. ■

