

# Through Dovetails

In these instructions for the Leigh D4R Pro Dovetail Jig, we have recommended certain bits and board sizes because they are easy to work with. When you have routed some practice joints and gained confidence in your ability to get the results you want, free to use the guidebush and adaptor selection charts in Appendix I, pages 69-70, and bit options in Appendix II, pages 71-77, to plan whatever dovetail routing you need for your projects.

## Concept of Jig Operation – THROUGH DOVETAILES

Start with the Finger Assembly in the  TD TAIL mode and follow these steps on your jig. Grasping the simple basic concept of operation will now greatly assist you in understanding the instructions. *Note that the active guide surface (against which the guidebush runs) is indicated in red in these illustrations.*

### 1 Start in Through Dovetail Tails (TD TAILS) mode

**MODE ICONS**

Illustrations in this user guide include the correct *mode* icon for the current instruction. The icons are also used in the instruction text.

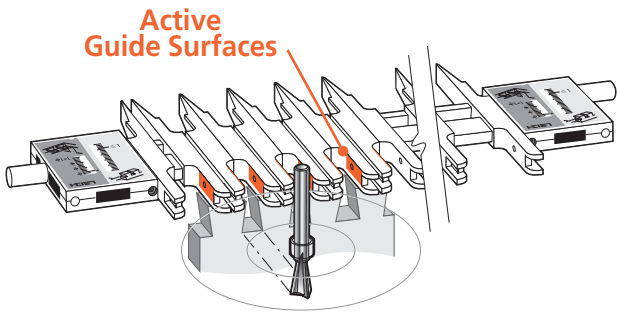
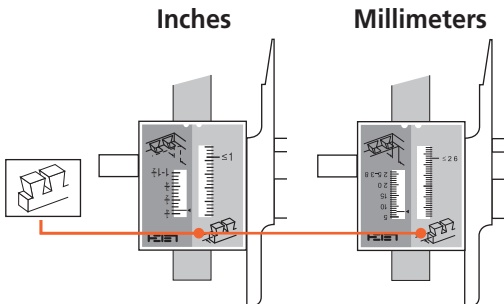

### 2 ROTATE the finger assembly toward you 180°

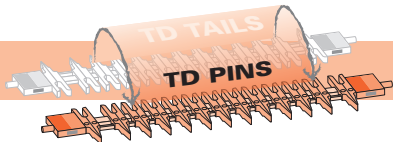

### 3 Now the Finger Assembly is in Through Dovetail Pins (TD PINS) mode

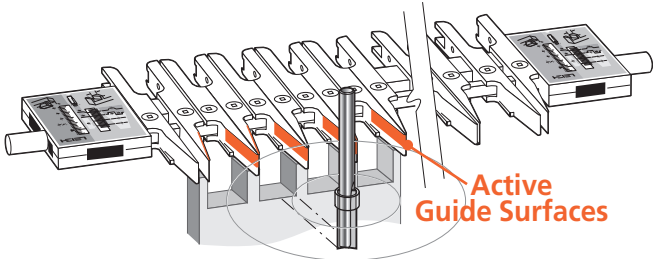
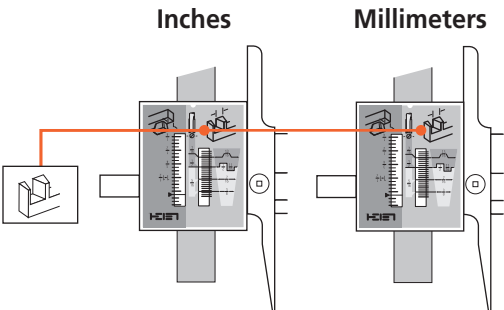

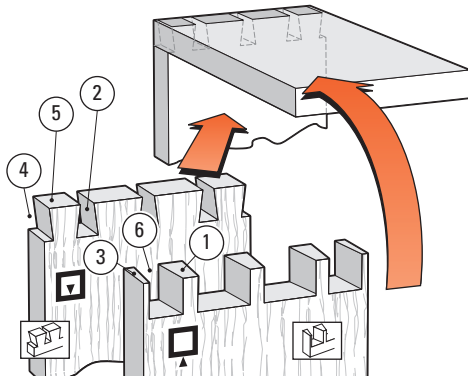

### 8-1 Through Dovetail Terminology:

- ① Pins
- ② Pin sockets
- ③ Half-pins
- ④ Half-pin sockets
- ⑤ Tails
- ⑥ Tail sockets

The pins fit in the pin sockets. Joints should almost always end each side with half-pins.

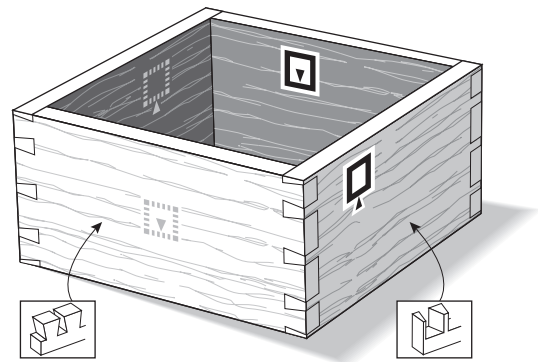

**8-2** Let's look at how to make a simple square box. When you assemble the finished pieces with the faces properly oriented, any one of the pin ends will fit any one of the tail ends. In fact, the box can be put together in six different ways ...each of the four corners will fit two ways!

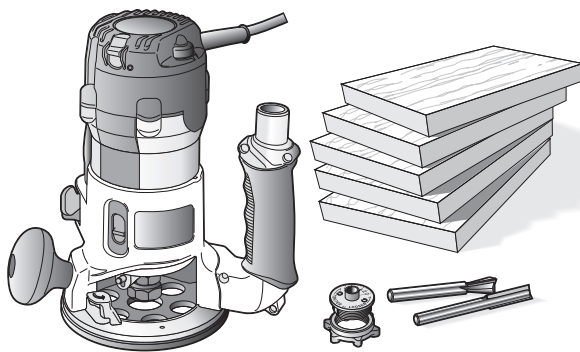

**8-3** Make five identical boards  $\frac{3}{4}$ " x  $5\frac{1}{2}$ " [20x140mm] about 8" [200mm] long. Mark the inside faces of the two tail boards and outside faces of the three pin boards (you may not need one of the pin boards). Use Leigh e7 or  $\frac{7}{16}$ " [11,1mm] O.D. guidebush with:

- No. 80-8  $\frac{1}{2}$ " [12,7mm] x  $8^\circ$  dovetail bit and
- No.140-8  $\frac{5}{16}$ " [7,9mm] straight bit.

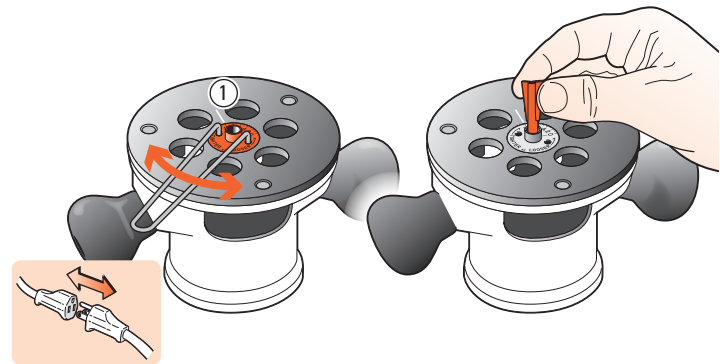

**8-4** Fit the e7-Bush or  $\frac{7}{16}$ " [11,1mm] securely to the router and set it to the No.10 index mark ①. Then fit the supplied 80-8 dovetail bit to the router. **Note:** The e7 guidebush is not used to adjust joint tightness with through dovetails.

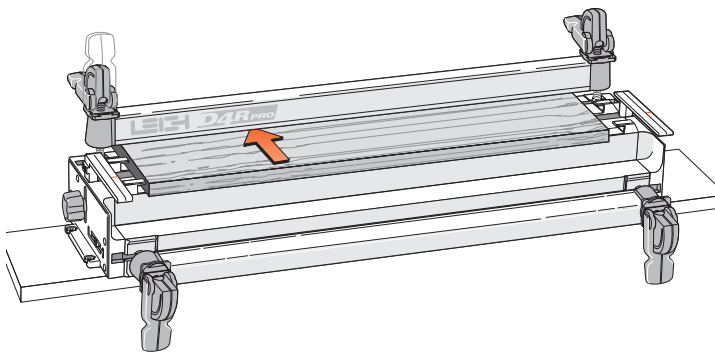

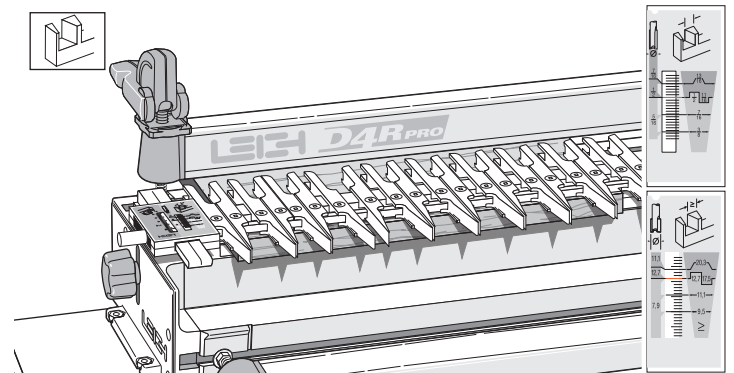

**8-5** Clamp the spacer board in the rear clamp.

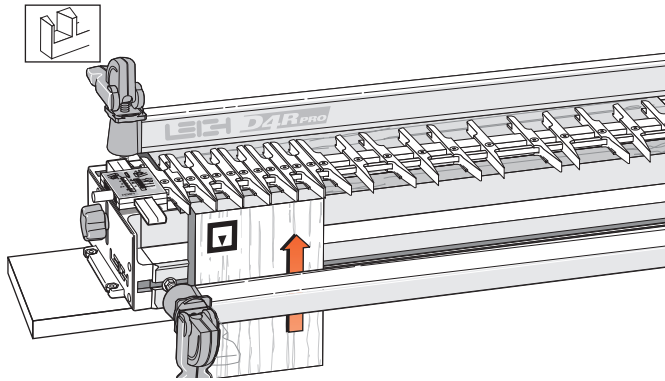

**8-6** Place the finger assembly on the support brackets in the TD PINS mode, flat on the spacer board, and with the scale set on the  $\frac{1}{2}$ " [12,7mm] setting for now. Don't worry about the scale's specific meaning now. Each scale's use will be fully explained in the appropriate section.



**8-7** Clamp a tail board against the left front side stop, top edge touching flush under the guidefingers, inside face  away from the jig body. Although you will cut tails first, adjust the guidefinger layout in  TD PINS mode. The adjustment screws are on top in this mode, and it's easier to visualize the final joint pattern.

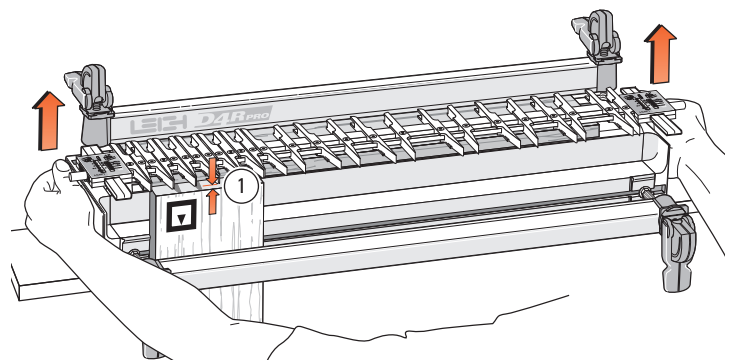

**8-8** Loosen the support bracket knobs and raise the finger assembly about  $\frac{1}{8}$ " [3mm]  above the boards and retighten the knobs. This will allow easy and accurate guidefinger adjustment.

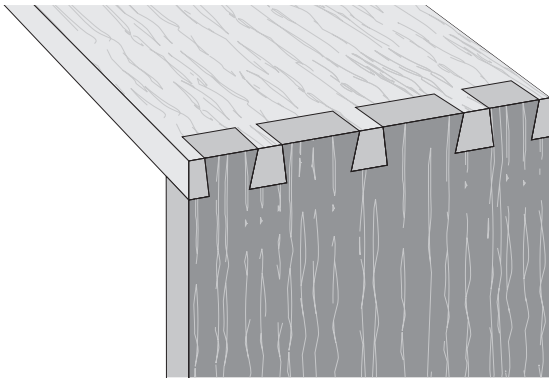

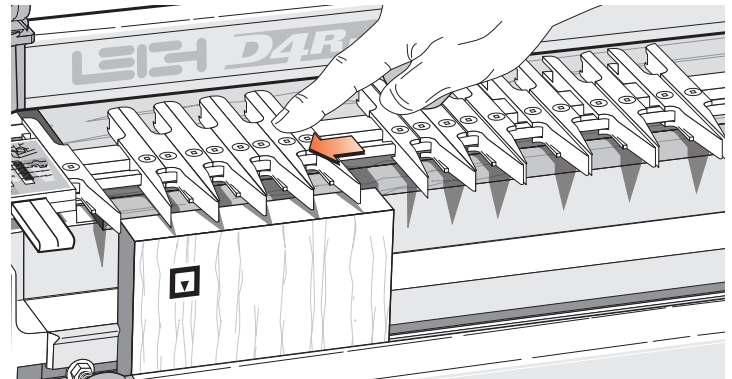

**8-9** This joint layout is only a suggestion for this trial. It has a typical, traditional **symmetrical** layout of pins, with half-pins at each edge. The Leigh jig, however, allows for an infinite variety of joint designs, and boards of different thicknesses can also be joined to each other as shown in this illustration. Before attempting joints of **asymmetrical** layout, please see chapter 14.

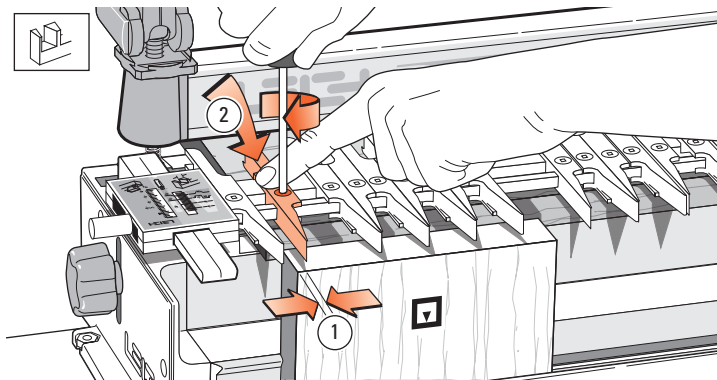

**8-10** Ignoring the extreme outer guidefinger next to the scale (it just supports the router), loosen the next eight guidefingers and slide them over the workpiece. *NOTE: The first few times you use your jig, some fingers may "stick". This is normal. To "unstick", loosen the finger screw about 3/4 turn. Press down firmly on the screwdriver (in the screw) to loosen the finger locking wedge (you should feel a click).*



**8-11** Lock the left-most half-pin guidefinger about  $\frac{1}{8}$ " [3mm]  in from the left edge of the board. Always apply light downward pressure to each guidefinger as the finger screws are tightened . This will ensure the fingers are flat and level on the bar.

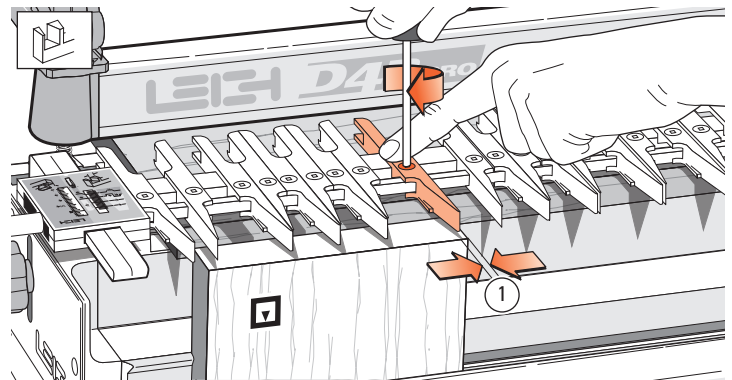

**8-12** Leave three pairs of guidefingers over the board and lock the right-most half-pin guidefinger about  $\frac{1}{8}$ " [3mm]  in from the right edge of the board. Judge this distance by eye: it need not be exact. The sockets and pins will align automatically.

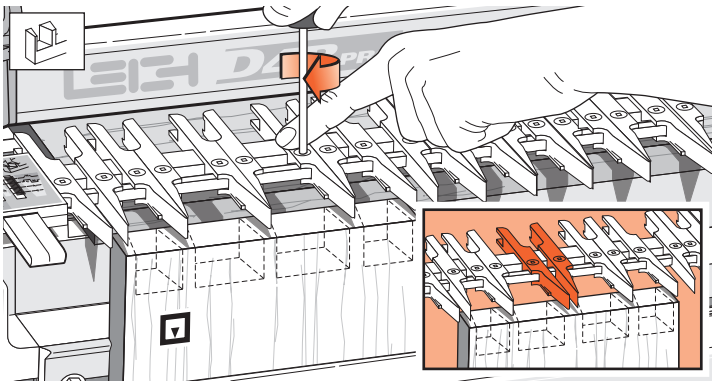

**8-13** Space and lock the three remaining pairs as shown. Again, judge it by eye. If it looks right on the jig, the finished joint will look right. Note: Here we have shown pins of equal width, but with tails of increasing width. However, by opening up a pair of guides, the pin (and pin socket) can be widened for decorative or structural reasons as shown in the drawing inset.

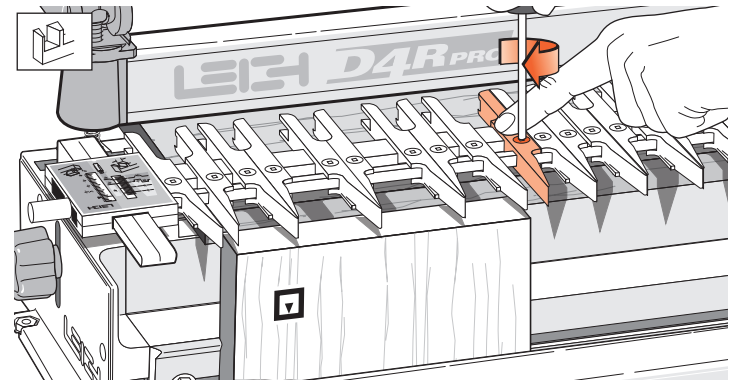

**8-14** Tighten any other loose guidefingers.

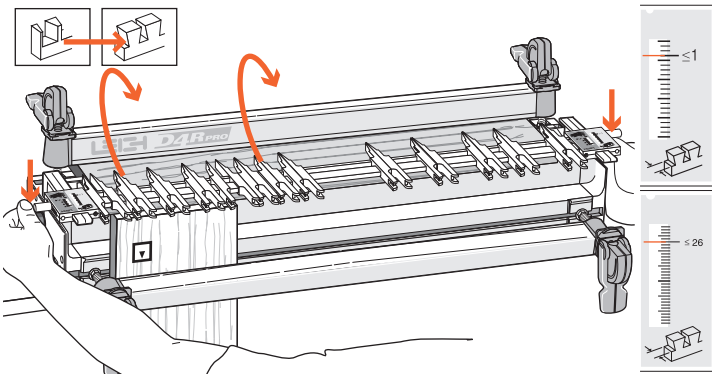

**8-15** Rotate the finger assembly to the TD TAILS mode, and set it to the  $\le 1''$  [ $\le 26\text{mm}$ ] position on the scale. Lower the finger assembly onto the spacer board. All TD tails are routed at this  $\le 1''$  [ $\le 26\text{mm}$ ] setting. (The  $\le 1''$  setting allows the dovetail bit to pass completely through all tail boards.)

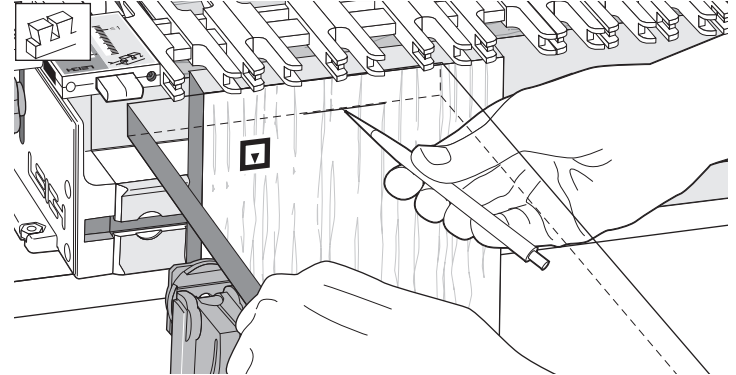

**8-16** Place the end of a *pin board* horizontally flush under the guidefingers and mark a thin pencil line partly across the tail board.

 **REMEMBER SAFETY!**

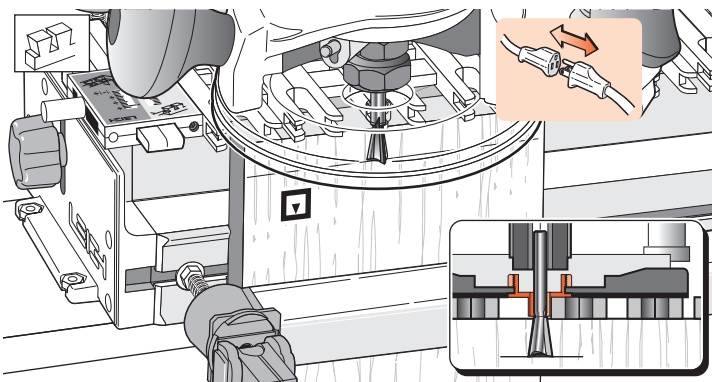

**8-17** Place the router on the finger assembly and adjust the router until the dovetail bit tip is level with the center of the pencil line. Note: This means the pin socket will be half a thin pencil line deeper than the thickness of the pin board, leaving minimal cleanup after assembly. Check to make sure the bit rotates freely.

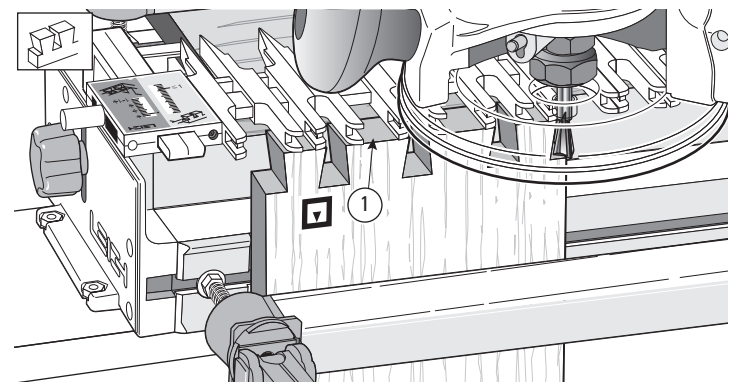

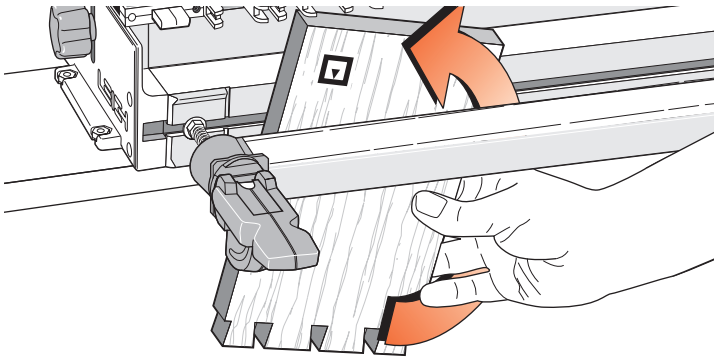

**8-18** Before routing the tails, read "Hints and Tips 17-10". Plug in the router and rout out the half-pin and pin sockets. Use only light side pressure on the guide fingers. Take care not to rout unwanted sockets where there are gaps between the pairs of fingers ①. Rout only between the rounded guidefinger tips. See Hints and Tips 17-20.



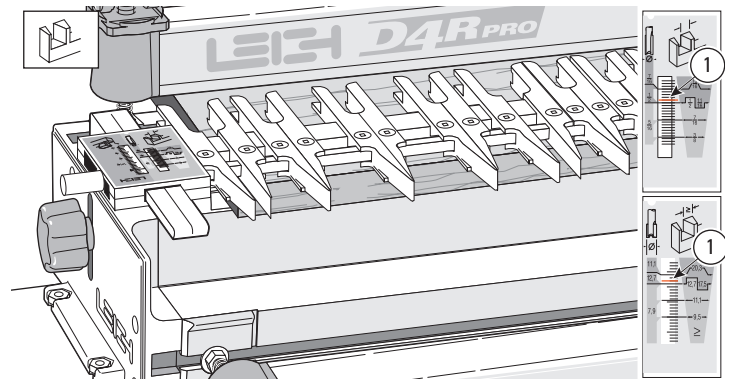

**8-19** Before removing the routed board from the jig, check by eye and touch to make sure no parts have been missed. Release the clamp and reverse the tail board in the jig, keeping the same inside face  away from the jig body. Rout the other end of this tail board and both ends of the second tail board in the same fashion, then unclamp and put them aside.



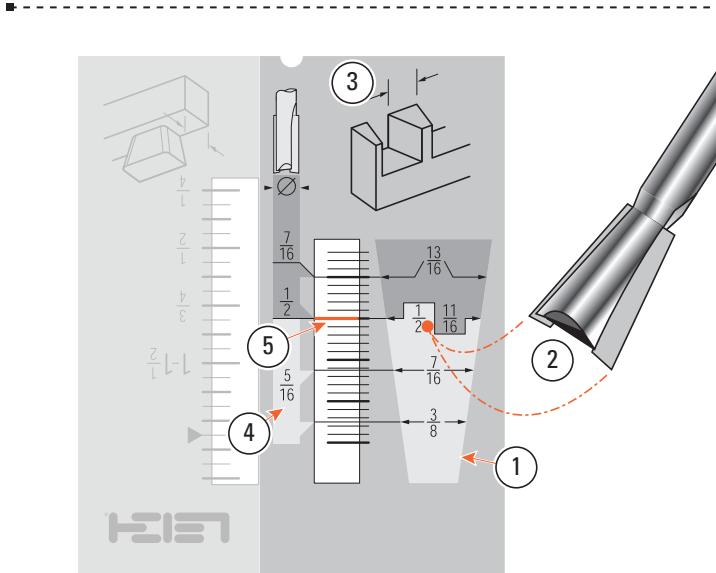

**8-20** Rotate the finger assembly to the  TD PINS mode and set it one scale increment more than the  $\frac{1}{2}$ " [12,7mm] mark . Do not change the guidefinger layout.



**8-21 How the TD PIN Scales Work**



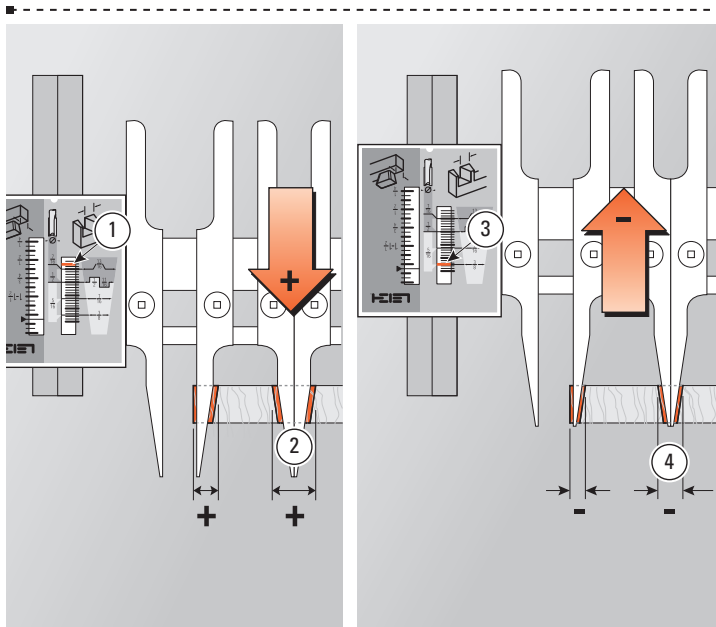

Dimensions inside the pin shaped panel  correspond with the diameter of the dovetail bit chosen to rout the tails . In this example the  $\frac{1}{2}$ " [12,7mm] diameter of the #80-8 dovetail bit matches the  $\frac{1}{2}$ " [12,7mm] setting on the scale. This also becomes the width of the pin .

Dimensions in the central panel  indicate which straight bit diameter is required with the selected dovetail bit, i.e.  $\frac{5}{16}$ " [7,9mm] straight bit with the  $\frac{1}{2}$ " [12,7mm],  $\frac{7}{16}$ " [11,1mm] and  $\frac{3}{8}$ " [9,5mm] diameter dovetail bits.

The increment lines in the scale window  are referenced to the index lines on the support brackets when making fit adjustments. Once the desired fit is achieved, settings can be recorded for precise setup next time.



**8-22 Finished Joint Tightness**

The fit of the finished joint is determined in the  TD PINS mode. Moving the finger assembly outward  increases the width of the pins , giving a tighter fit. Moving the finger assembly backwards  allows more wood to be routed, making the pins smaller , and the joint looser. A one increment movement changes joint fit by 0.005" [0,125mm]. A one quarter increment movement changes fit by a tiny 0.00125" [0,03mm]. Most importantly, when that fine fit is achieved, it allows recordable and repeatable settings for future joints using the same router and bits (see page 28).

**Why can't there be specific, preset scale settings for each bit combination?**

Cumulative tolerances in routers, bits, guidebushes and the dovetail jig, make it impossible to give exact jig settings for a precision glue joint. A fine fitting joint can only be attained by trial and error test cuts, and takes only minutes for each bit combination. Dimension lines on the TD PIN scale provides the starting point for testing.

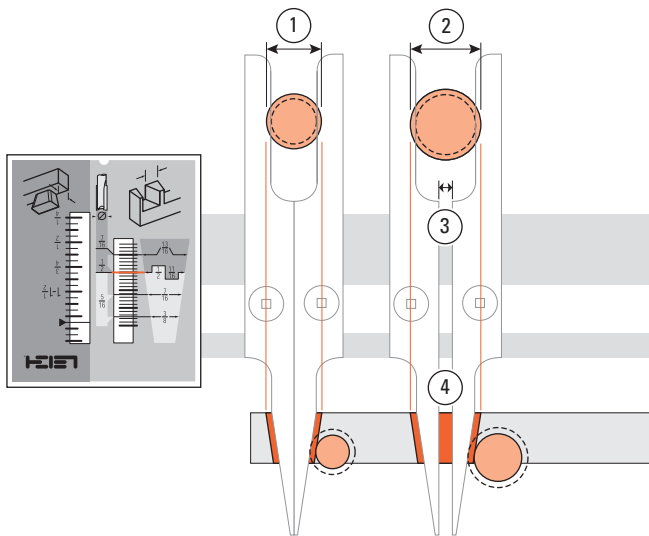

### 8-23 Why are the 1/2" and 1 1/16" [12,7&17,5mm] pin widths on the same scale line?

1/2" through dovetails are routed using a 7/16" guidebush ①  
 1 1/16" through dovetails are routed with a 5/8" guidebush ②.  
 That's a 3/16" difference in size between the two bits ... and between the two guidebushes.  
 The 5/8" diameter guidebush for 1 1/16" joints requires that the guide fingers be opened up by 3/16" ③.  
 This automatically makes the pins 3/16" wider ④ but on the same scale setting.

### 8-24 Do the guide fingers have to be opened up precisely 3/16" [4,75mm] for larger combinations?

No, just so long as they are opened up by at least 3/16" (4,75mm) ① to allow the larger guidebush to enter the tail guides. Anything more than this minimum is fine ②; both the pin and matching pin socket widths will be automatically increased by exactly the same amount, whatever the spacing. Varying the pin width does not affect the joint fit or the scale setting. In fact, the pin width can be varied with all bit combinations, not just the larger bits

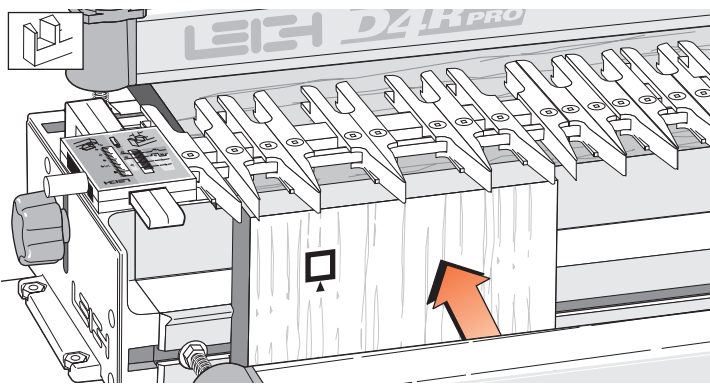
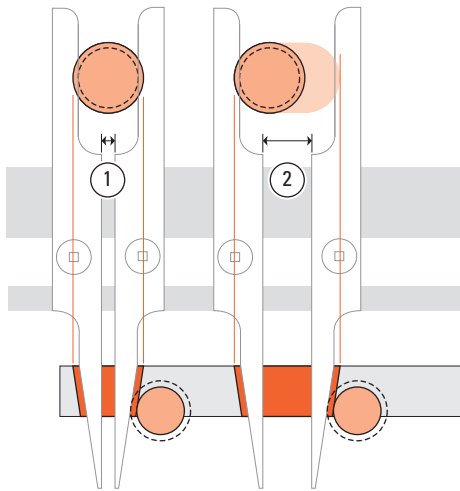

**8-25** Clamp a test pin board against the left hand side stop, outside face  $\square$  away from the jig, with the top end flush under the guides.

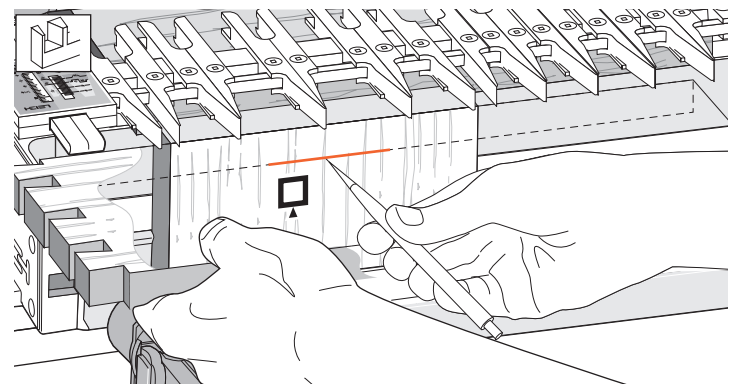

**8-26** Place the side edge of one of the finished *tail boards* horizontally flush under the guidefingers and mark a thin pencil line part way across the pin board.

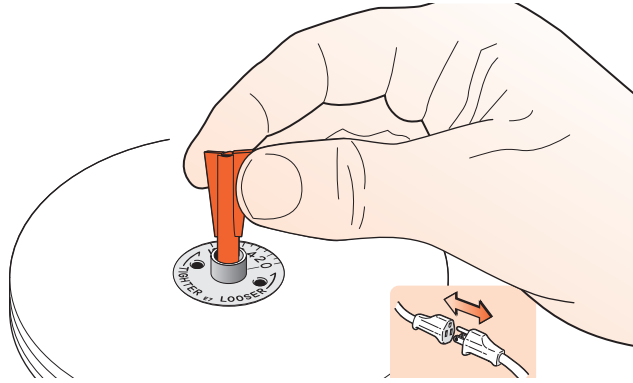

**8-27** Unplug the router and remove the dovetail bit. Mount the No. 140-8 straight bit to the router. *If you are using two routers, see concentricity concerns, Figures 7-6 thru 7-8.*

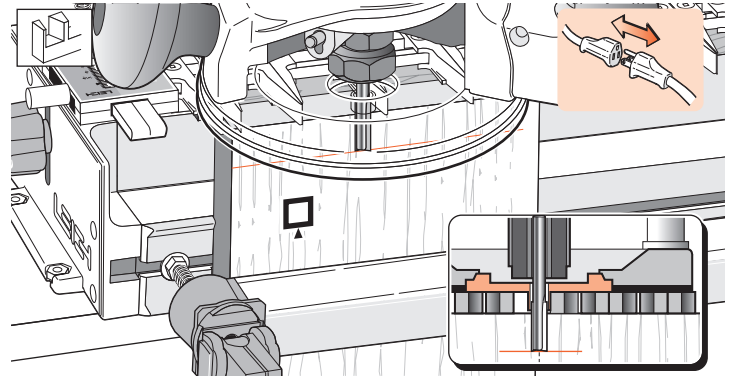

**8-28** Place the router on the finger assembly and adjust the router until the tip of the bit is level with the center of the pencil line. Check to make sure the bit rotates freely.

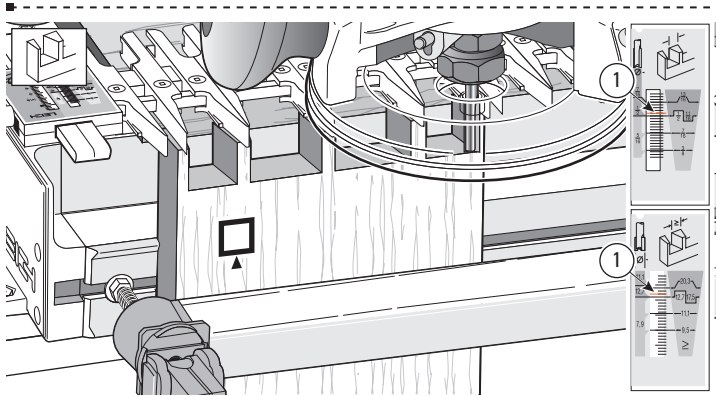

**8-29** Check that the scales are set one increment above the 1/2" [12,7mm] mark ①. Rout out the waste between the pins. Check to make sure no parts have been missed. *See 17-1 to 17-5, "Hints and Tips" on how to minimize tearout. Use only light side pressure on the guide fingers.*

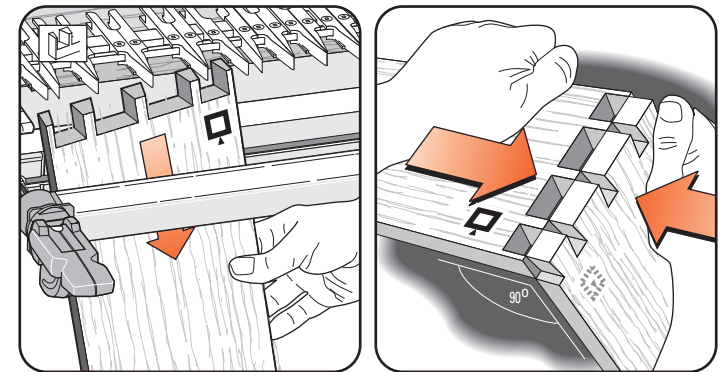

**8-30** Remove the test pin board from the jig and test it for fit in one of the tail boards. *Make sure the outside faces □ face outward on both pieces.* The joint will probably be too tight. A firm push fit is perfect, perhaps a tap with the heel of your hand. But having to use a mallet means the joint is too tight to take glue.

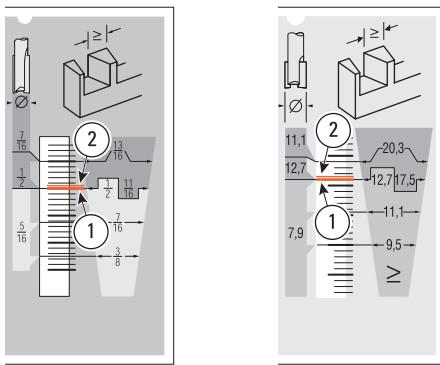

**8-31** If it is much too tight, move the finger assembly in (away from you) by one division on the scale. If it is only a little tight, adjust the scale by only half a division. If it is too loose, go to 8-33.

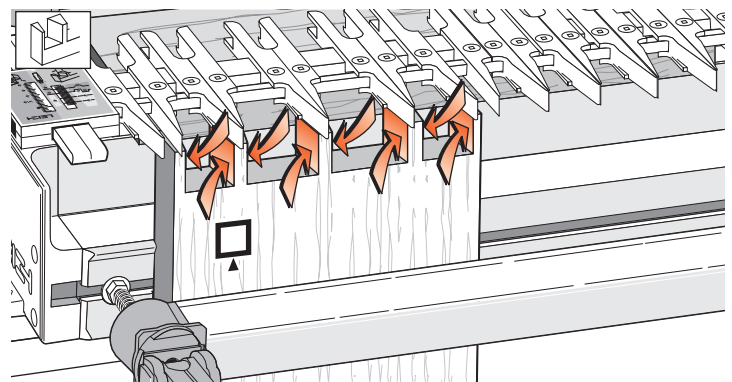

**8-32** Replace the same pin board back in the jig, carefully aligned against the same side stop. Rout off the sides of the pins and test it again for fit.

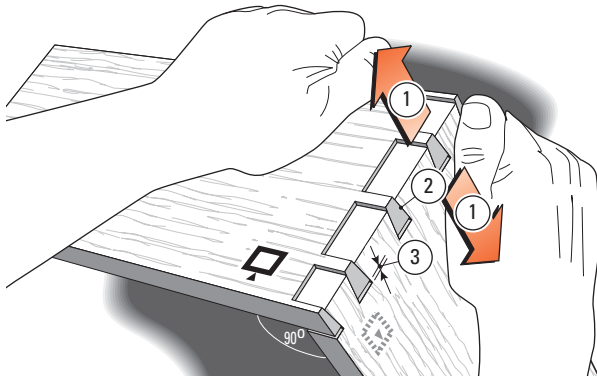

**8-33** Test and repeat as required to achieve the desired fit.  
*Note: If you overdo it and make a loose joint, do this test. Pull the tail board “away” from the pins ① so that the angled sides of the pins and tails jam together ②. The gap between the bottom of the pins and the pin sockets ③, is the amount to move the finger assembly out, (toward you). Reset the finger assembly and test again on the other end of this (fifth) board.*

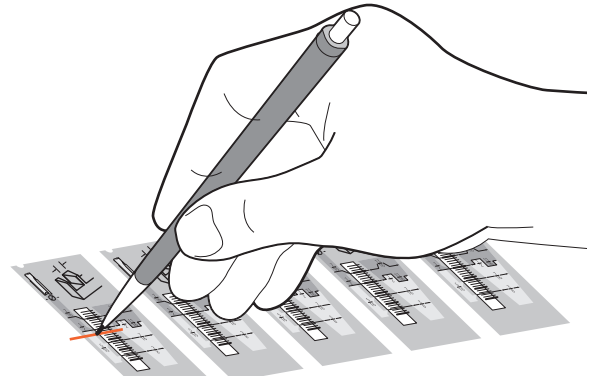

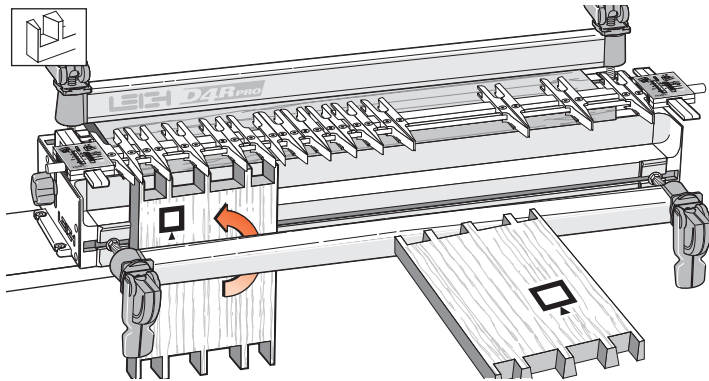

**8-34** Once the correct fit is achieved, mark the final TD PINS scale setting on one of the scale prints (see page 28) for future reference. Very slight variations to the scale setting may be necessary with different wood species or hardness.

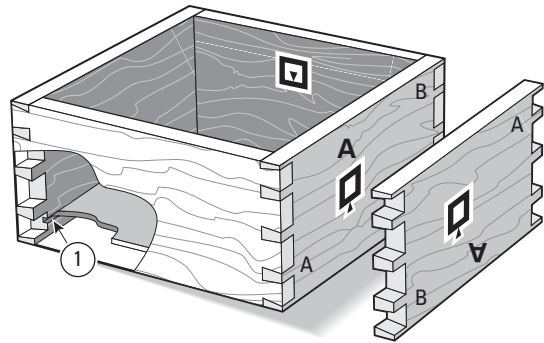

**8-35** Rout all four ends of the pin boards, keeping the outside face  outwards. (With luck you may not have used the fifth board.)



**8-36** Assemble the box, making sure the tail boards face the proper way, i.e. tail boards inside face in ; pin boards outside face out . Provided you haven't already routed out the drawer bottom grooves ①, it doesn't matter which edge of any of the boards are at the top or bottom, the box will still fit together i.e. pin board “A” can be up either way.

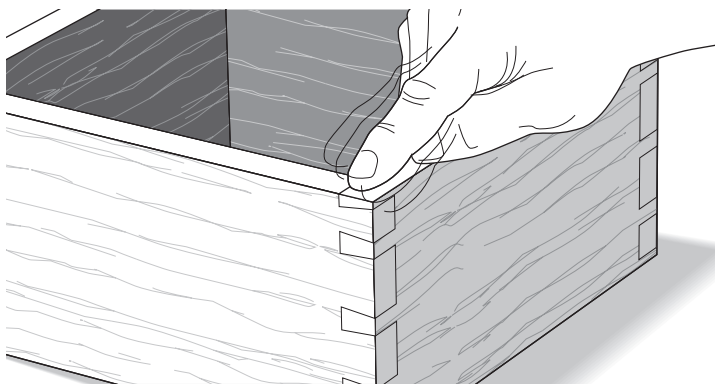

**8-37** The box should be square and in plane. If it is not in plane (i.e., the side edges of each board are not in line), then either the ends of the boards are not square, the board widths are not exactly equal, or there is a concentricity problem (see 7-6 to 7-8).

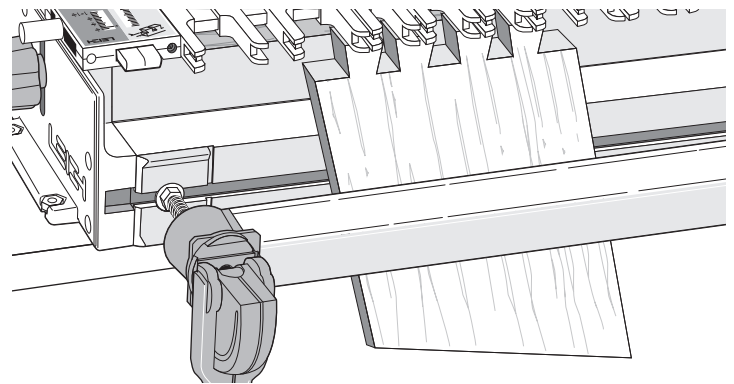

**8-38** To form angled dovetails, refer to the Technical Bulletin “How to Rout Angled Through Dovetails on your Leigh Jig”. You can download this bulletin from the support page of our website: <http://www.leighjigs.com/support.php>. ■

QUICK REFERENCE REMINDERS

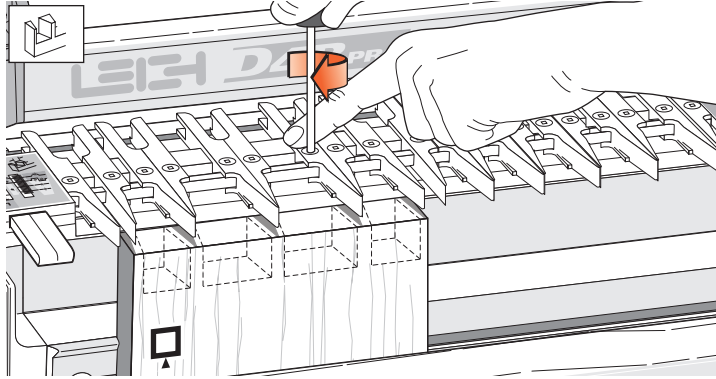

**8-39** Through dovetails are laid out in the TD PINS mode with the finger assembly slightly raised above the spacer board. The outside face of the TD pins is away from the jig body.

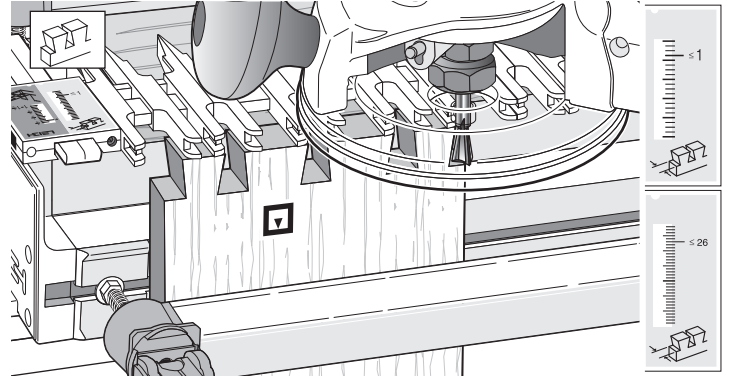

**8-40** TD tail boards are clamped vertically in the jig. The inside face of the TD tails is away from the jig body. The finger assembly is in the TD TAILS mode, set on the single  $\le 1''$  setting. There is only one setting in this mode.

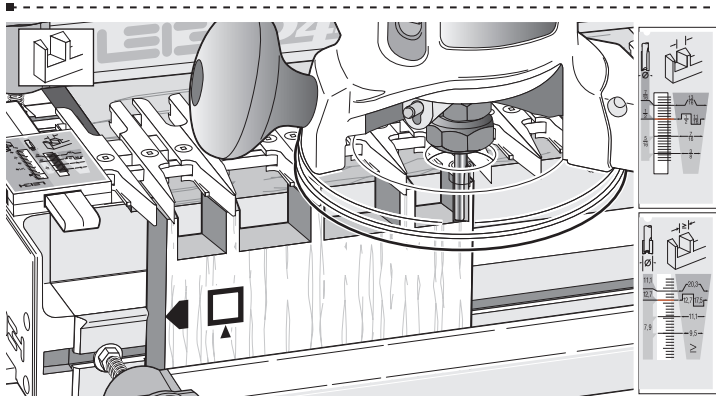

**8-41** Clamp TD pin boards vertically in the jig. This is the only one of the four main modes that puts the outside face of the board away from the jig body. The finger assembly is in TD PINS mode, with the scale set to a recorded setting (see detailed fit instructions 8-21 to 8-34). TD pins are cut with a straight bit; the only time a straight bit is used in dovetailing.

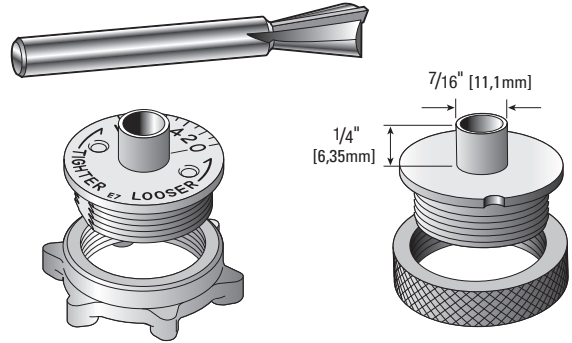

**8-42** Through dovetail tails are always routed with an 8° dovetail bit to match the 8° guide finger. All through dovetail routing on the D4R Pro is done with the Leigh e7-Bush, or any  $7/16''$  diameter bush (min. barrel length  $1/4''$ ). See page 70 for more on routers and guide bushings. The 716C or a  $5/8''$  O.D. guidebush is used for  $1/2''$  shank TD bits. See Chapter 9.

Thickness of Tail Board	Thickness of Pin Board	Dovetail Bit	Straight Bit	Guidebush Diameter
$1/8'' - 1''$ [3-26]	$1'' - 1 1/4''$ [26-32]	No.100	No.150	Leigh 716C or $5/8''$ [15,9]
	$5/8'' - 1''$ [16-26]	No.90	No.160	
	$1/2'' - 13/16''$ [12-20]	No.80-8	No.140-8	Leigh e7 or $7/16''$ [11,1]
	$3/8'' - 5/8''$ [10-16]	No.75-8		
	$1/4'' - 1/2''$ [6-13]	No.70-8		
	$1/8'' - 3/8''$ [3-10]	No.60-8		
$1/8'' - 1/4''$ [3-6]	No.50-8			

Numbers in brackets are millimeters

**8-43** Here is a quick reference selection chart for through dovetail bits and guidebushes. Please study the bit and guidebush selection appendixes for a full explanation.

PROJECT SETTINGS

INCHES

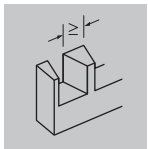
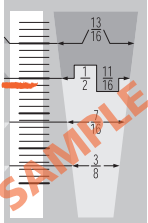
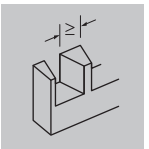
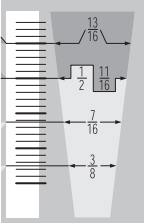
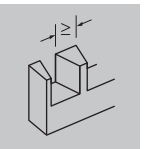
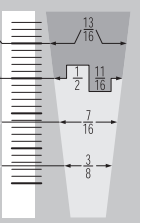
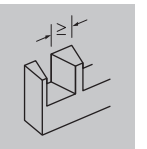
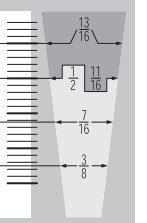
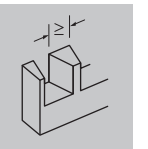
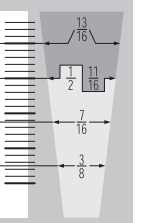
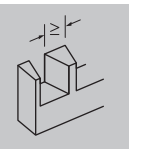
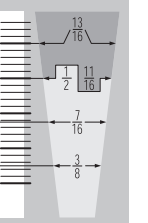
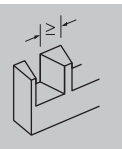
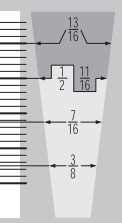
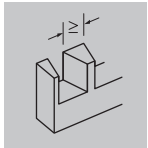
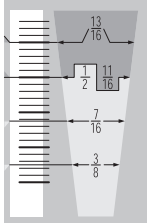
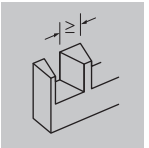
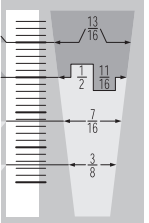
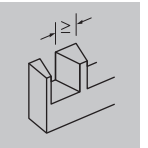
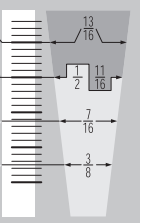
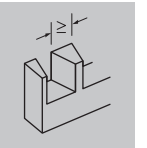
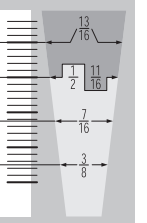
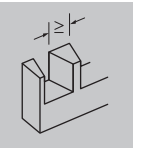
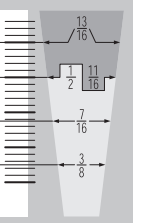
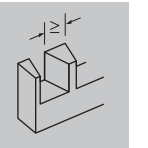
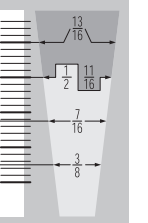
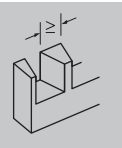
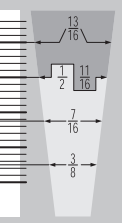
  <input type="text" value="80-8"/>	  <input type="text"/>	  <input type="text"/>	  <input type="text"/>	  <input type="text"/>	  <input type="text"/>	  <input type="text"/>
  <input type="text"/>	  <input type="text"/>	  <input type="text"/>	  <input type="text"/>	  <input type="text"/>	  <input type="text"/>	  <input type="text"/>

METRIC

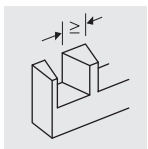
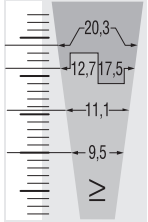
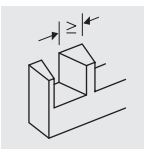
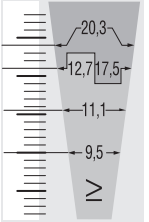
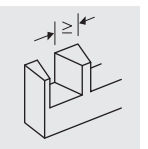
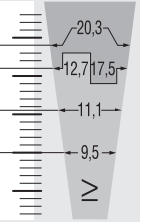
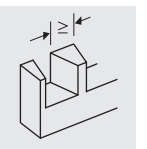
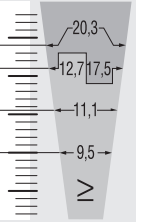
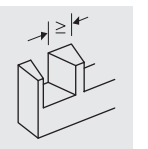
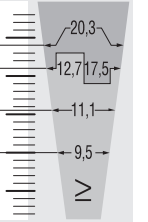
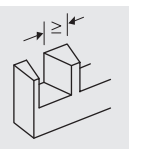
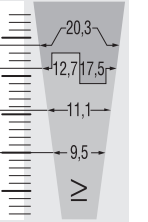
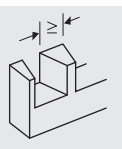
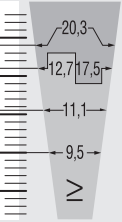
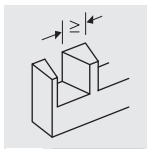
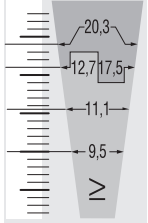
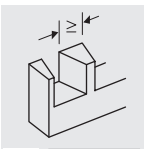
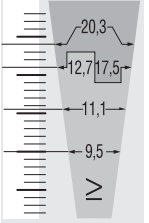
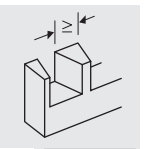
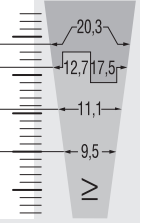
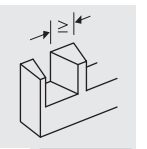
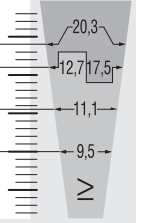
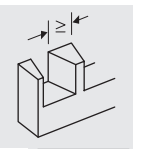
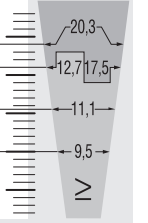
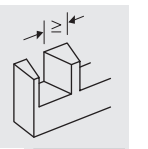
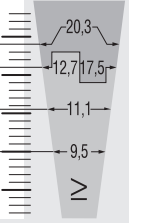
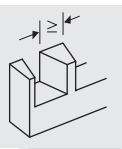
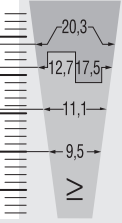
  <input type="text"/>	  <input type="text"/>	  <input type="text"/>	  <input type="text"/>	  <input type="text"/>	  <input type="text"/>	  <input type="text"/>
  <input type="text"/>	  <input type="text"/>	  <input type="text"/>	  <input type="text"/>	  <input type="text"/>	  <input type="text"/>	  <input type="text"/>