

RTJ400 OPERATION

CHAPTER 8 Half Pitch Through Dovetails

Note: Optional Leigh bits and the e7 guide bushing are required in order to make half pitch through dovetails. See Step 8-2 below and pages 3 to 6 for complete details of optional items, router table requirements and the RTJ400 Accessory Kit.

IMPORTANT SAFETY NOTE
Before using your Leigh RTJ400 you must have completed the preparatory steps listed in the previous pages, including reading the jig safety recommendations in Chapter 3.

8-1 Getting Started

Review this drawing and joinery terms to get a clear understanding of how the boards fit together.

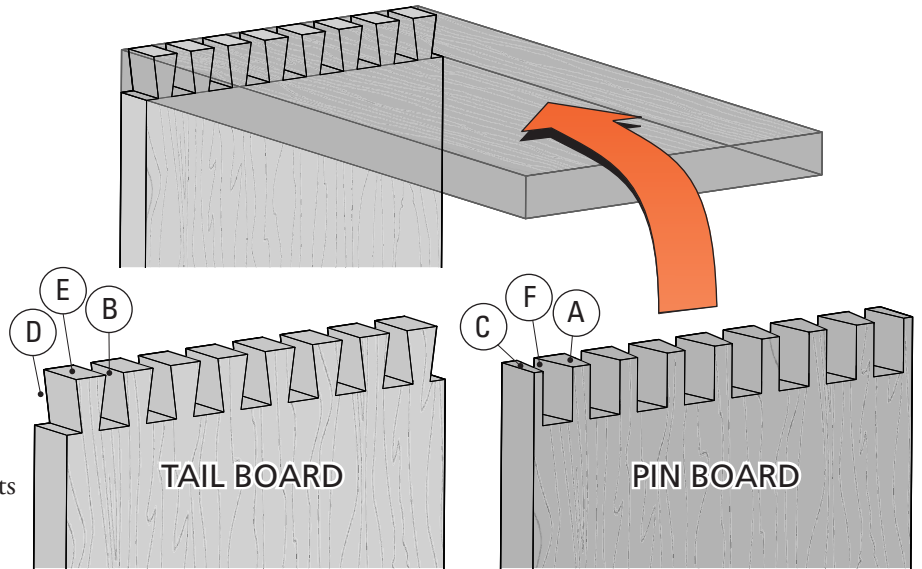
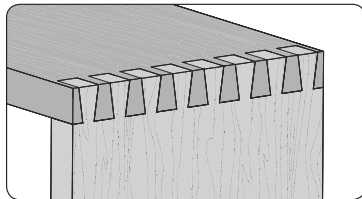

- (A) Pins
- (B) Pin sockets
- (C) Half-pins
- (D) Half-pin sockets
- (E) Tails
- (F) Tail sockets

8-2 Bits, Guide Bushings and Collet Reducer



e10 Guide bushing

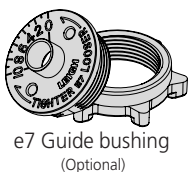

e7 Guide bushing (Optional)



Collet reducer, 172-8 for 8mm bits (Optional)

Half pitch through dovetail *tails* are routed using the included e10 guide bushing and one of four optional 8mm through dovetail bits. **Note:** 8mm bits must be used with a 8mm collet or 172-8 (1/2" to 8mm) collet reducer. Half pitch through dovetail *pins* are routed with the optional e7 guide bushing and 140-8 or equivalent straight bit. The e7, all five bits and the 172-8 are available individually or in the RTJ400 Accessory Kit (ACRT) at leighjigs.com. See bit specs on page 4.

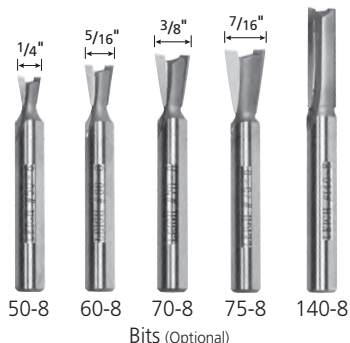

HALF PITCH THROUGH DOVETAIL BIT CUTTING DEPTH						
All through dovetail bits have 8° angles. All carbide bit heights are slightly greater than maximum depth of cut listed.						
Depth of Cut	Bit No.	50-8	60-8	70-8	75-8	140-8
1/4"	1/8"	Denotes Depth of Cut Range				
1/2"	3/8"					
3/4"	5/8"					
1"	7/8"					

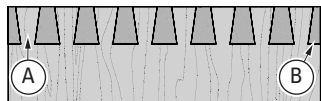

Board widths are based on the number of full tails **A** in your design. Board edges should always end in a half-pin **B**.

Board Width Selection for Half Pitch Through Dovetails

No. of Tails	1	2	3	4	5	6	7	8	9	10	11	12	13	14	15	16	17	18	19	20	
Inches	Min	2 ³ / ₃₂ "	1 1/2"	2 ⁹ / ₃₂ "	3 1/16"	3 ²⁷ / ₃₂ "	4 3/8"	5 ¹³ / ₃₂ "	6 3/16"	6 ³¹ / ₃₂ "	7 3/4"	8 ¹⁷ / ₃₂ "	9 3/16"	10 ³ / ₃₂ "	10 7/8"	11 ²¹ / ₃₂ "	12 ⁷ / ₁₆ "	13 ⁷ / ₃₂ "	14"	14 ²⁹ / ₃₂ "	15 9/16"
	Exact	2 ⁵ / ₃₂ "	1 9/16"	2 ¹¹ / ₃₂ "	3 1/8"	3 ²⁹ / ₃₂ "	4 11/16"	5 ¹⁵ / ₃₂ "	6 1/4"	7 ¹ / ₃₂ "	7 ¹³ / ₁₆ "	8 ¹⁹ / ₃₂ "	9 3/8"	10 ⁵ / ₃₂ "	10 ¹⁵ / ₁₆ "	11 ²³ / ₃₂ "	12 1/2"	13 ⁹ / ₃₂ "	14 1/16"	14 ²⁷ / ₃₂ "	15 5/8"
	Max	2 ⁹ / ₃₂ "	1 11/16"	2 ¹⁵ / ₃₂ "	3 1/4"	4 ¹ / ₃₂ "	4 ¹³ / ₁₆ "	5 ¹⁹ / ₃₂ "	6 3/8"	7 ⁵ / ₃₂ "	7 ¹⁵ / ₁₆ "	8 ²³ / ₃₂ "	9 1/2"	10 ¹⁰ / ₃₂ "	11 1/16"	11 ²⁷ / ₃₂ "	12 5/8"	13 ¹³ / ₃₂ "	14 3/16"	14 ³¹ / ₃₂ "	15 3/4"
Millimeters	Min	18	38	58	77	97	117	137	156	176	196	216	235	255	275	295	314	334	354	374	393
	Exact	20	40	59	79	99	119	138	158	178	198	217	237	257	277	296	316	336	356	375	395
	Max	23	43	62	82	102	122	141	161	181	201	220	240	260	280	299	319	339	359	378	398

8-3 Use this chart to determine the board width for your project. Through Dovetail joints may be routed in boards up to 5/8" thick for pin boards and 1" thick for tail boards. Board widths are determined by the total number of full tails in the joint design. **Note: Board widths may be wider than the chart width by half of the dovetail bit diameter or less than the chart width by one quarter of the dovetail bit diameter.**

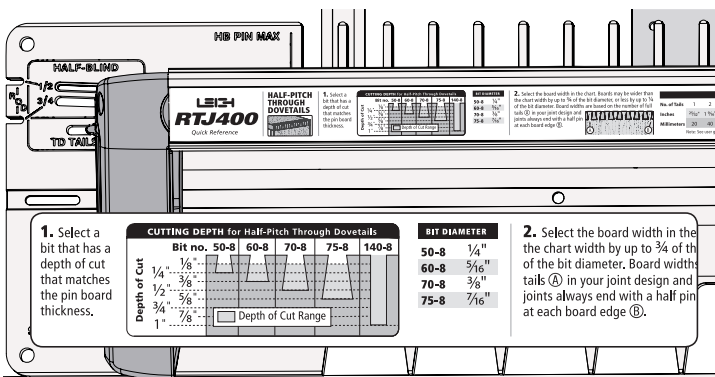

8-4 Use the Quick Reference strip to determine the correct dovetail bit and guide bushing combination for the board thickness, in this case, the Leigh e10 guide bushing and the optional 3/8" Leigh 70-8 dovetail bit for tails and the optional e7 guide bushing and Leigh 140-8 straight bit for pins.

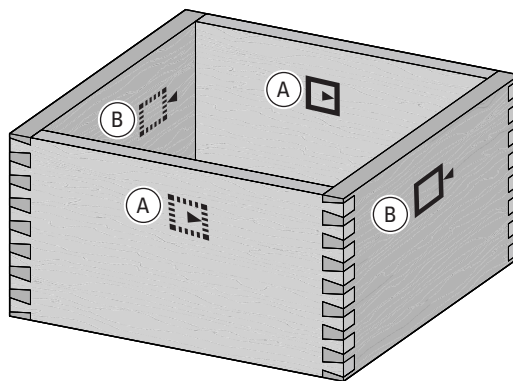

8-5 Making a Box Note the symbols indicating the inside or outside of the pin and tail boards. When assembled with the finished pieces properly oriented, any one of the pin ends will fit any one of the tail ends. **Mark the inside faces of the tail boards A and outside face of the pin boards B.**

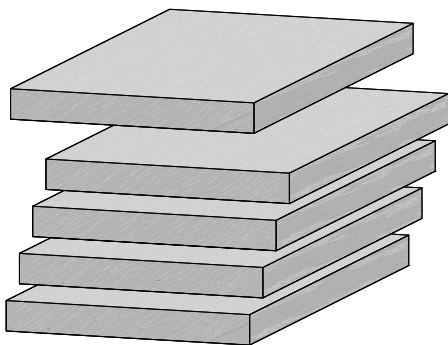

8-6 Prepare five similar boards (one for testing) about 1/2" x 6 1/4" by about 12" long [13mm x 159mm x 305mm]. Boards of different thicknesses may also be joined.

IMPORTANT: Read this whole chapter before routing any boards.

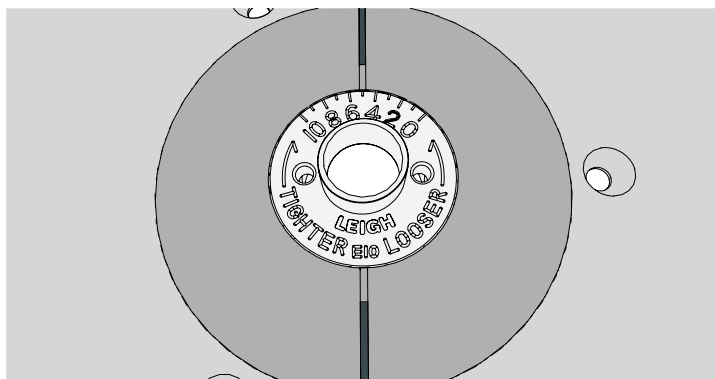

8-7 Fit the e10 eBush to the router table insert ring, set to 5.

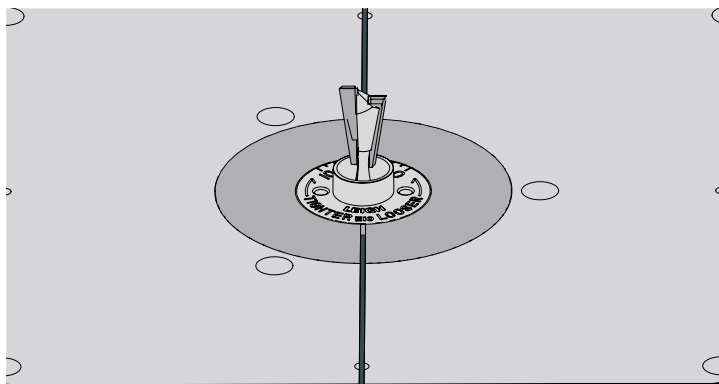

8-8 With the router unplugged, install the Leigh 70-8 dovetail bit. ⚠ Make sure the bit spins freely within the guide bushing before reconnecting the power.

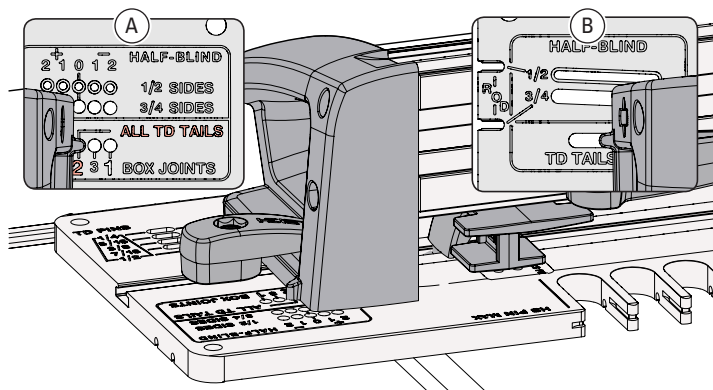

8-9 Insert the right frame pin in the **No.2 hole** of **ALL TD TAILS** mode (A) and the left frame pin in the corresponding **TD TAILS & BJ slot** (B). Securely latch the frame.

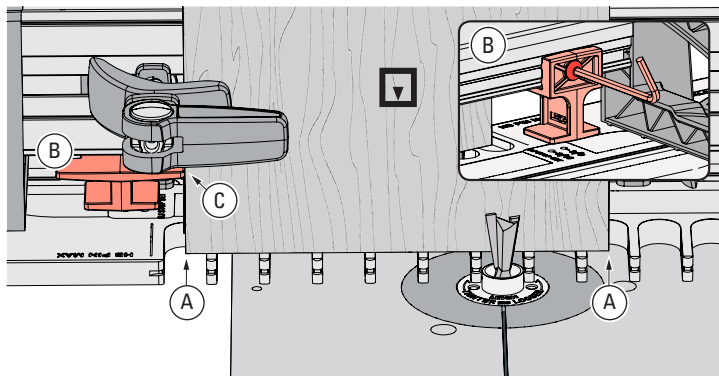

8-10 Center tail board 1 (A) over the template with the marked inside face showing out, bottom end flush on the template, and clamp. From the other side of the frame, slide the side stop (B) to touch the tail board (C) and tighten with the hex driver.

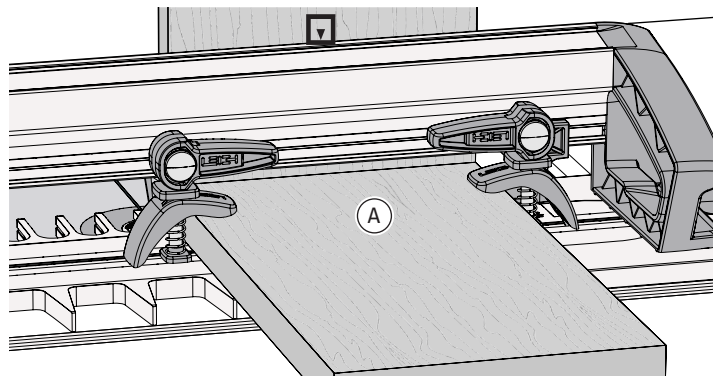

8-11 Clamp a short scrap backer board (A) horizontally against the tail board to help prevent tear out and direct chips and dust away. This can stay in place for routing of all consecutive tail boards. The scrap board should be at least as thick as the cutting depth of the bit in Step 8-13.

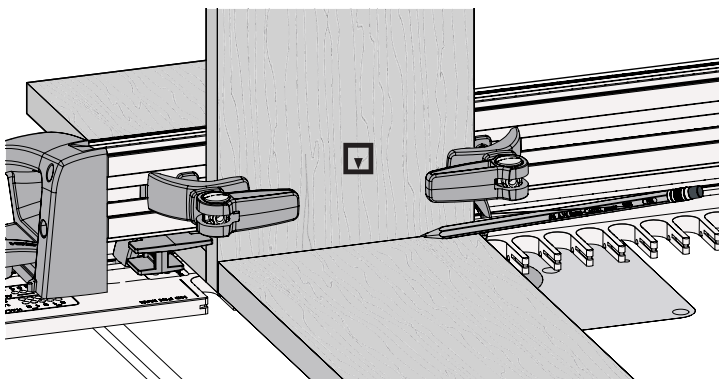

8-12 Place the edge of a pin board on the template and pencil a line on the tail board.

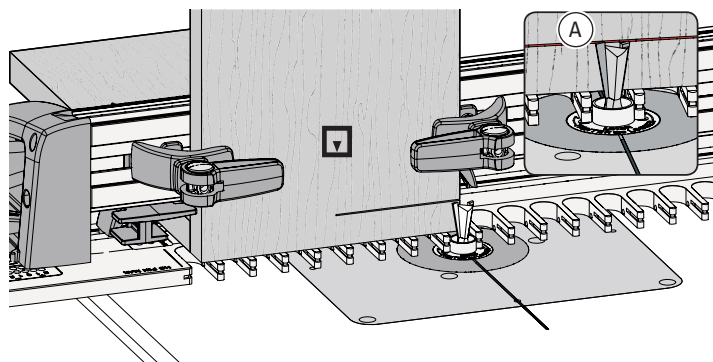

8-13 Position the jig close to the dovetail bit and adjust the bit height until the bit tip is touching the center of the line (A). ⚠ Double check that the bit still rotates freely. **Note: Make sure you are using the e10 eBush set on 5.**

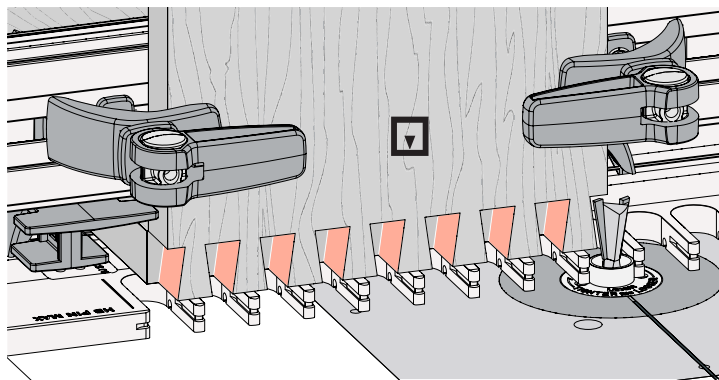

8-14 Rout the tails in every template opening. ⚠ The eBush must touch one side of the opening as you enter and the other side as you exit. Rotate tail board 1 and rout the other end. Repeat routing for tail board 2. Remove the tail board and backer board. **Disconnect the power and remove the e10 eBush & dovetail bit.**

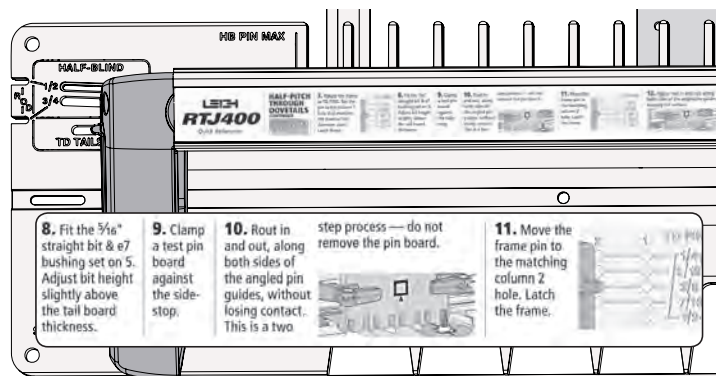

8-15 Check the Quick Reference strips for the correct guide bushing and bit selection for half pitch pins. **Note:** Half pitch dovetails always use the optional e7 guide bushing and the optional Leigh 140-8 straight bit. For cleaner routing, use the optional $\frac{5}{16}$ " Leigh 170 (HSS) or 170C (solid carbide) spiral upcut bit.

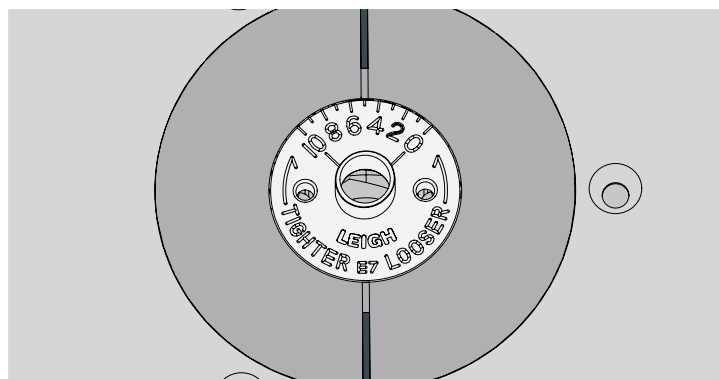

8-16 Fit the e7 eBush to the router table/router table insert, set to 5.

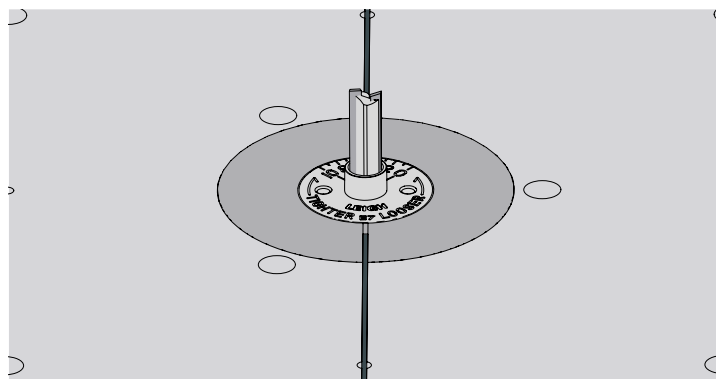

8-17 With the router unplugged, install the $\frac{5}{16}$ " [8mm] 140-8 straight or equivalent spiral bit. ⚠ Make sure the bit spins freely within the eBush before reconnecting the power.

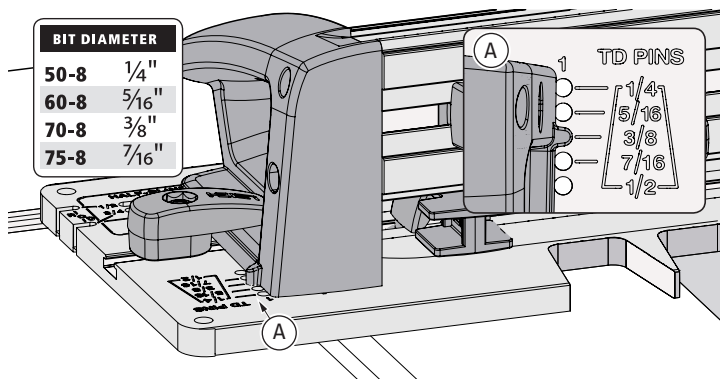

8-18 Rotate the frame to the **TD PINS** mode. Insert the right frame pin in the **Column 1 hole** that matches the dovetail bit diameter that was used to rout the tails, $\frac{3}{8}$ " in this example (A), and the left frame pin in the matching slot. Latch the frame.

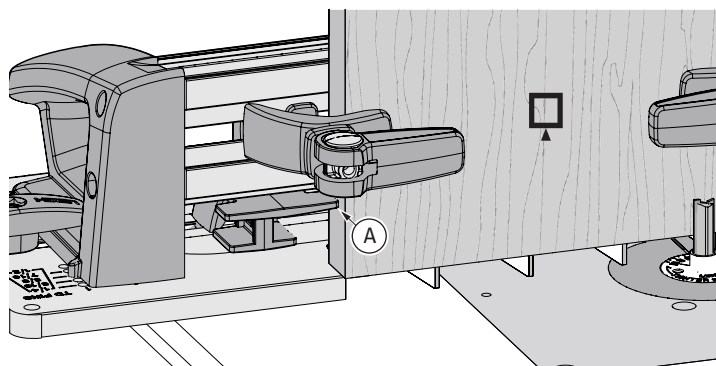

8-19 Clamp the **test** pin board in the jig with its edge against the side stop (A) with the marked outside face out and the bottom end edge flush on the template. **Note: The side stop was set when routing the tails, so no adjustment is needed.**

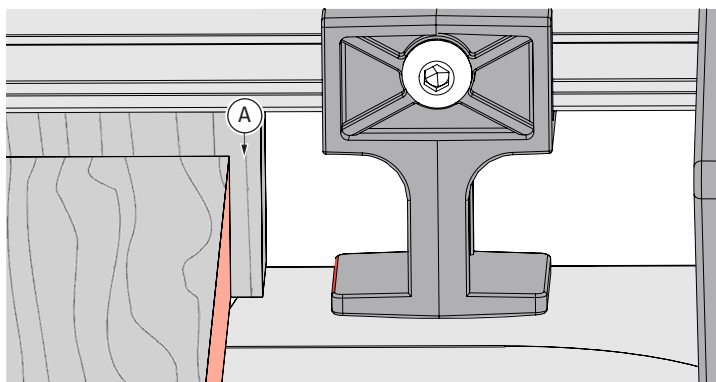

8-20 Position a backer board 1/2" [13mm] from the board edge (A). This prevents the backer board from interfering with the side stop when the frame is repositioned in the second step. The backer board stays in place for the complete procedure. **Note: Clamps removed for clarity.**

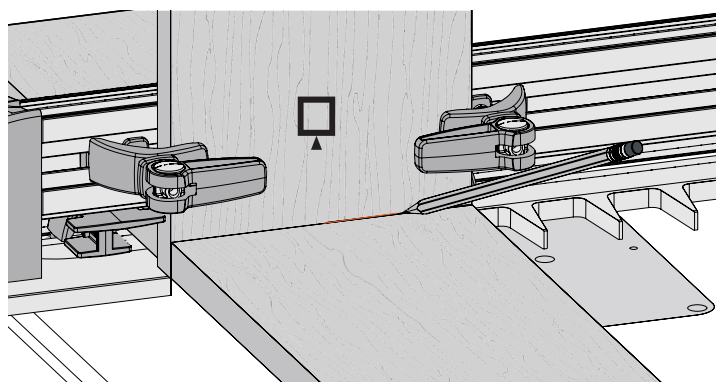

8-21 Place the end of a tail board on the template and pencil a line on the pin board.

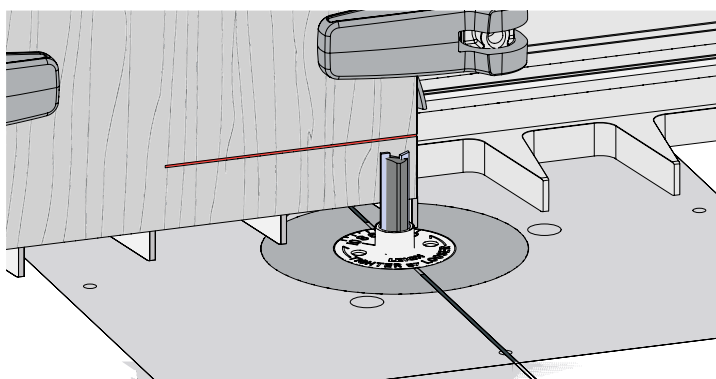

8-22 Adjust the bit so the tip of the bit is in the center of the pencil line. ⚠ Double check that the bit still rotates freely. **IMPORTANT: Bit height determines the flushness of the joint, so set your bit properly the first time.** Adjustments for flushness are near the end of the chapter.

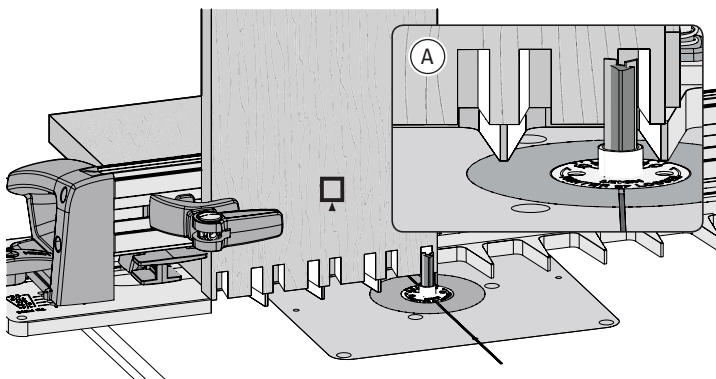

8-23 ⚠ Very carefully, **without losing guide bushing contact with the angled finger surfaces (A)**, rout in and out, both sides of the angled fingers. **This a two step process – DO NOT remove the pin board or backer board.**

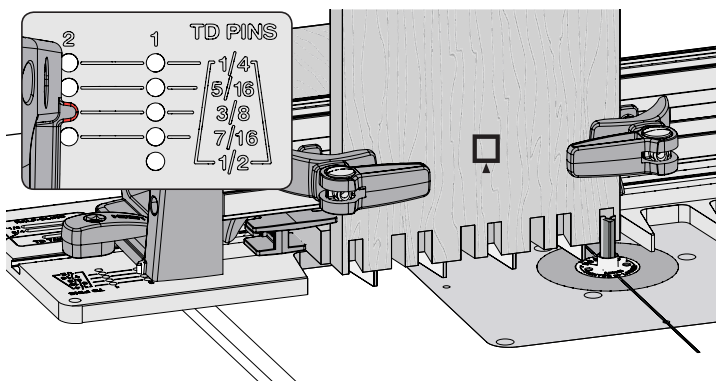

8-24 Move the frame pin to the **Column 2 hole** of the **3/8" TD PINS** mode. (A) Latch the frame.

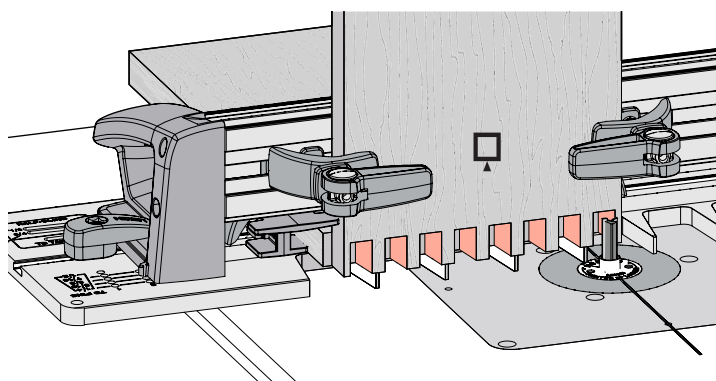

8-25 Again, very carefully rout in and around both sides of the angled pin guides, **without losing guide bushing contact with the surface of the angled template fingers.**

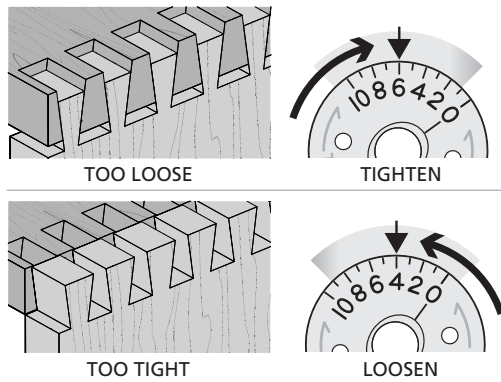

8-26 Test for Fit If the joint is too loose, turn the eBush to a higher number with the pin wrench as shown in the next step. If the joint is too tight, turn the eBush to a lower number. Each increment on the eBush changes the joint glue line fit by 0.002" [0.05mm]. Half an increment, a mere 1000th inch!

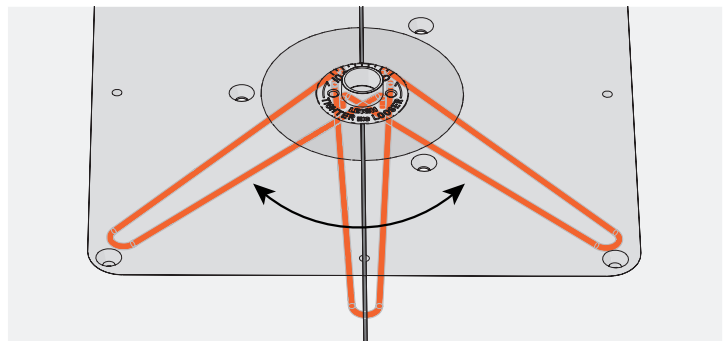

8-27 Re-tighten the eBush nut after each guide bushing adjustment. Rout a new pin board. Once the fit is correct, add the two eBush settings together and divide by two. **Example:** 5 for tails, 3 for pins ($5 + 3 = 8 \div 2 = 4$). Record setting "4" on an eBush diagram in the next step. Do not use this new setting for routing this test box, **only** for future projects.

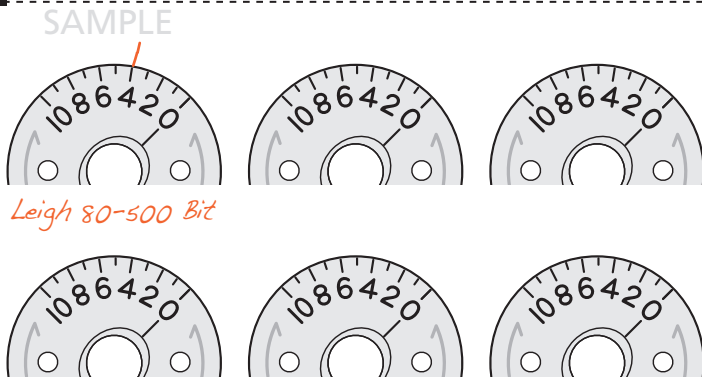

8-28 On the eBushes above, record the settings you used to achieve perfect joint fit. The first eBush is an example of how to record your setting.

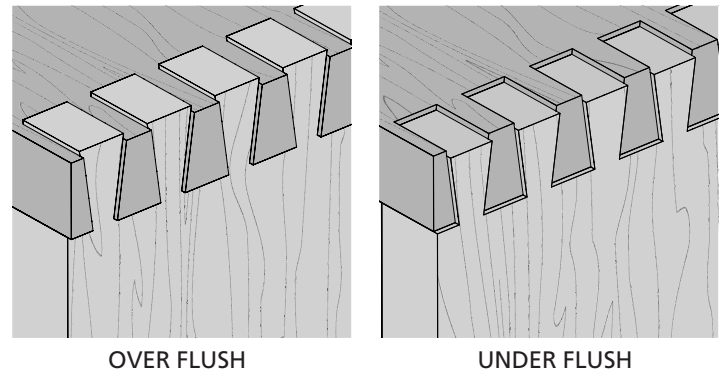

8-29 Flushness If the joint is over flush, lower the bit (decrease depth of cut). If the joint is under flush, raise the bit (increase depth of cut).

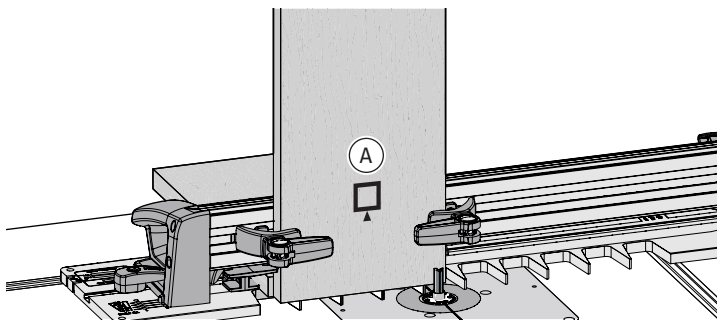

8-30 Utilizing the final fit setting you determined from Step 8-26 (not the calculated setting in 8-27), the two pin boards are now ready for routing. Reposition the frame to column 1. Clamp pin board 1 to the frame against the side stop with the marked outside face out (A) and the bottom end edge flush on the template. Now rout the first half of the pins. Reposition the frame to column 2 and finish the pins.

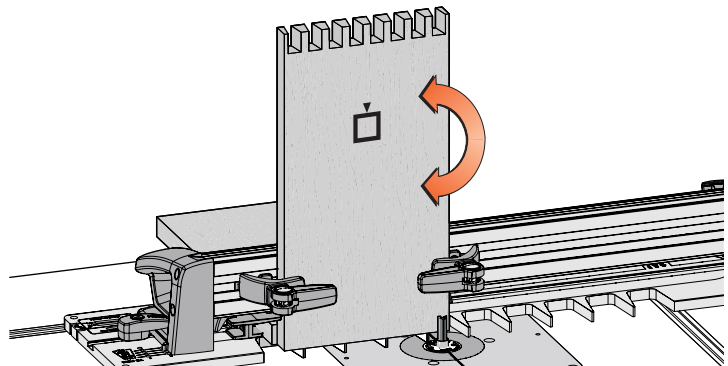

8-31 Rotate pin board 1 and rout the other end, repeating the steps in reverse order. Repeat routing for pin board 2. All four boards are now complete and ready for assembly. ■