

RTJ400 OPERATION

CHAPTER 11
3/4" Box (Finger) Joints

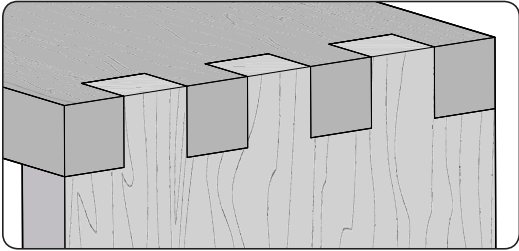

IMPORTANT SAFETY NOTE
Before using your Leigh RTJ400 you must have completed the preparatory steps listed in the previous pages, including reading the jig safety recommendations in Chapter 3.

11-1 Getting Started

Review the drawing below. **Symmetrical** joints have pins (A) on both edges of one board, and sockets (B) on both edges of the mating board. **Asymmetrical** joints have a pin (C) on one edge and a socket (D) on the other edge of each board.

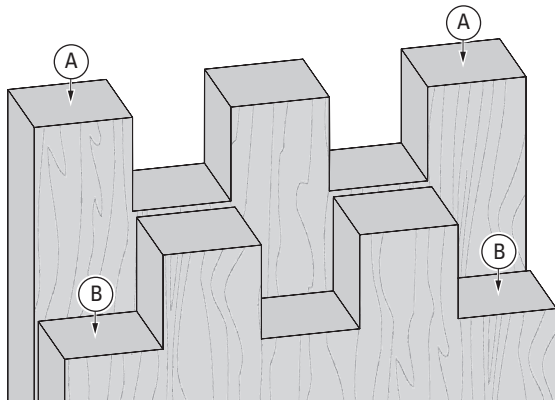

SYMMETRICAL

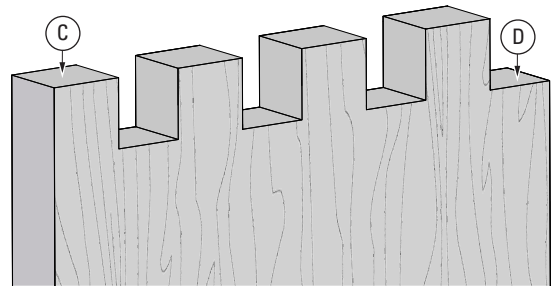

ASYMMETRICAL

11-2 Bits, Guide Bushing, Blockers and Stop Rod

3/4" box joints are routed with the included 3/8" straight bit 143-500 or optional 173-500 or 173-500C bits, the e10 guide bushing (eBush), blockers and stop rod (for positioning the side stop only). They can be routed in board thicknesses up to the maximum cutting depth of 1" [25.4mm].

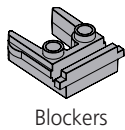

BOX JOINT BIT CUTTING DEPTH	
Bit Diameter	3/8"
Item No. Carbide Tipped	143-500
Item No. Spiral HSS (Optional)	173-500
Item No. Spiral Solid Carbide (Optional)	173-500C
Depth of Cut	0" -----
	1/4" -----
	1/2" -----
	3/4" -----
	1" -----

Stop Rod
(For positioning side stop)

11-3 Board Width Selection

Board widths are determined by the total number of pins and sockets in the joint design and whether the joint is symmetrical or asymmetrical. Use this chart to determine board widths up to 15 5/8" [397mm].

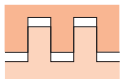

Symmetrical Joints have a full pin at each board edge. Total number of pins and sockets is always an odd number.

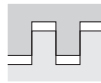

Asymmetrical joints have a full pin on one edge and a full socket on the other edge. Total number of pins and sockets is always an even number.

Symmetrical Board Width Chart for 3/4" Box Joints									
Total Pins & Sockets	3	5	7	9	11	13	15	17	19
Inches	2 11/32"	3 29/32"	5 15/32"	7 1/32"	8 19/32"	10 9/32"	11 23/32"	13 3/32"	14 27/32"
Millimeters	60	99	139	179	218	258	298	337	377

Asymmetrical Board Width Chart for 3/4" Box Joints									
Total Pins & Sockets	4	6	8	10	12	14	16	18	20
Inches	3 1/8"	4 11/16"	6 1/4"	7 13/16"	9 3/8"	10 15/16"	12 1/2"	14 1/16"	15 5/8"
Millimeters	79	119	159	198	238	278	318	357	397

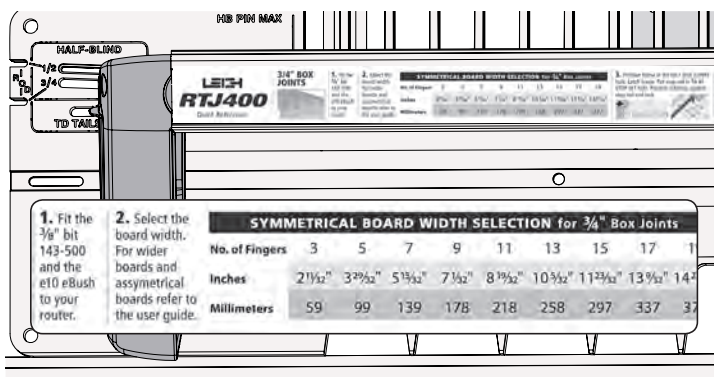

11-4 Use the Quick Reference strip to determine the correct straight bit and eBush combination. **IMPORTANT NOTE:** Read the whole chapter before routing any boards, and see quick fit instructions, Step 11-15.

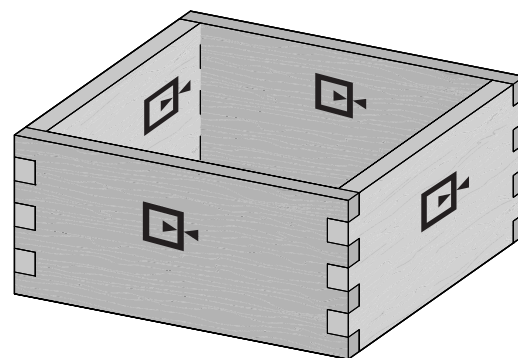

11-5 Making a Box Note the symbols indicating either side of the pin and socket boards can face in or out. With box joints, the same edge of the board goes against the side stop.

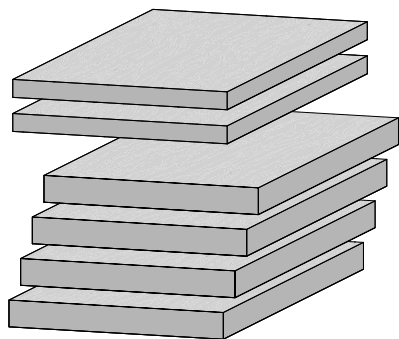

11-6 Prepare four similar boards about 3/4" x 5 15/32" by about 12" long [19mm x 117mm x 305mm]. For the quick fit test you will need two test boards about 1/2" thick. Boards of different thicknesses may also be joined. **IMPORTANT: Read this whole chapter before routing any boards.**

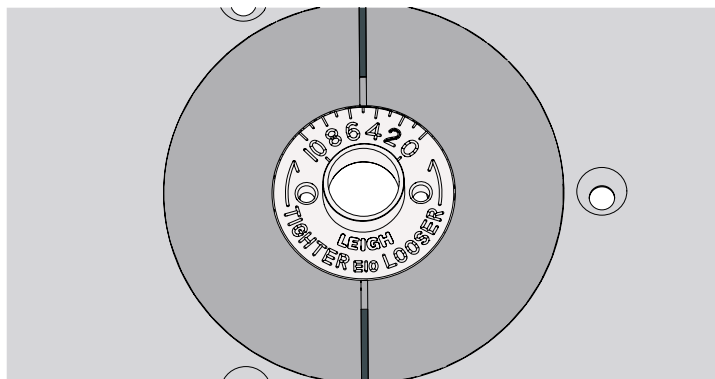

11-7 Fit the e10 eBush to the router table insert ring, set to 5. Or if you have already done the quick fit test, use this setting instead.

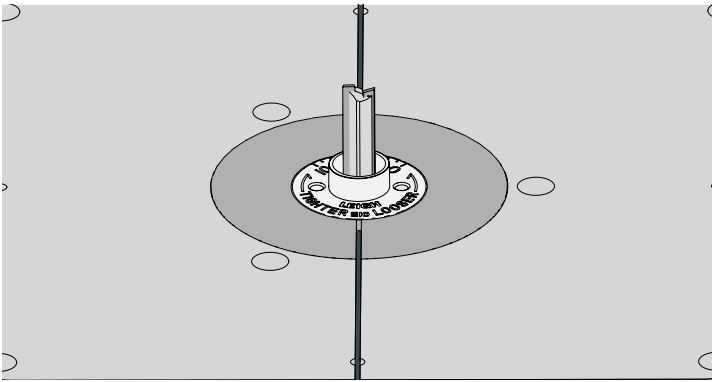

11-8 With the router unplugged, install the supplied 3/8" Leigh 143-500 bit. For cleaner routing use the optional 3/8" Leigh 173-500 (HSS) or 173-500C (solid carbide) spiral upcut bit, available at leighjigs.com. ⚠️ Make sure the bit spins freely before connecting the power.

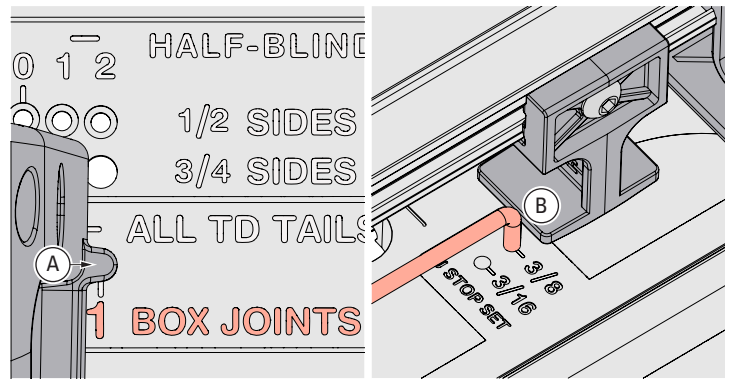

11-9 Insert the right frame pin in the **No.1 BOX JOINTS** hole (A) and the left frame pin in the matching slot, then latch the frame. Put the short end of the stop rod into the **3/8" BJ STOP SET** hole. Slide the side stop to lightly touch the rod (B) and tighten the stop. Store the stop rod in the 3/4" slot.

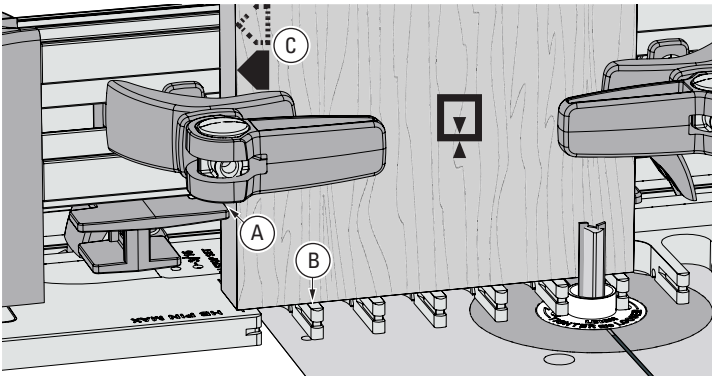

11-10 Clamp socket board 1 flush on the template (B) with the side edge against the side stop (A). **Always keep the same side edge of the board to the side stop when routing box joints** (C). If board width is only slightly narrower than the chart width, center the board over the template, clamp in place and move side stop to touch the board.

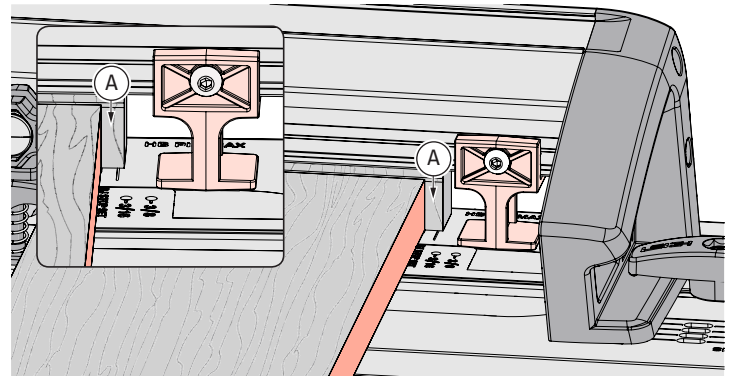

11-11 Position a backer board 1/16" [1.5mm] away from the edge of the socket board (A). This prevents the backer board from interfering with the side stop when the frame is repositioned in the second step. The backer board stays in place for the complete procedure. **Note: Clamp removed for clarity.**

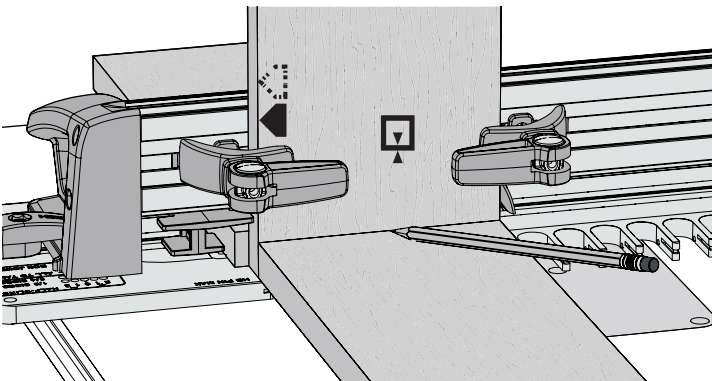

11-12 Place the end of a pin board on the template and pencil a line on the tail board.

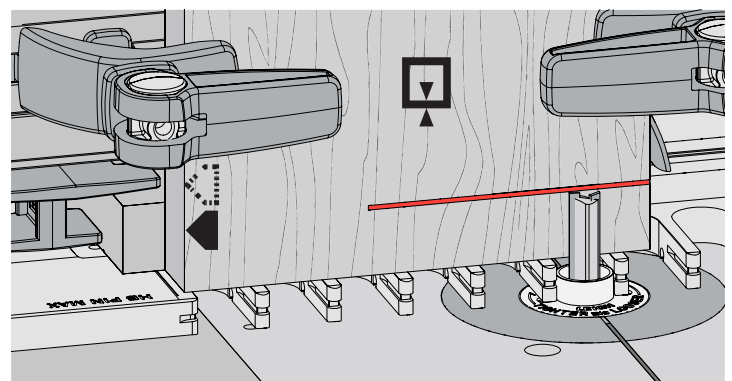

11-13 Adjust the bit to the center of the line. ⚠️ Double check that the bit still rotates freely. **IMPORTANT: Bit height determines the flushness of the joint, so set your bit properly the first time.** Adjustments for flushness are at the end of the chapter.

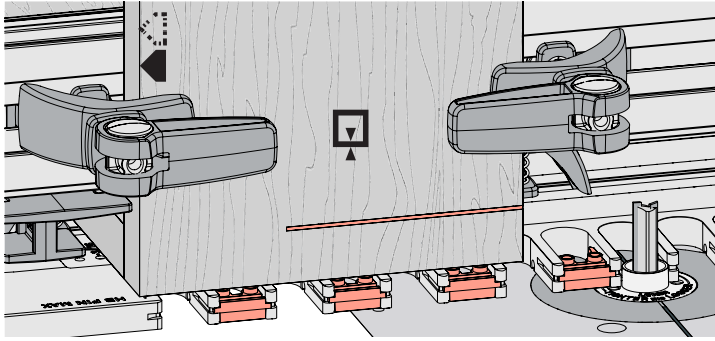

11-14 This procedure requires routing into alternating template openings. To prevent routing the wrong sockets, insert the supplied blockers into each even numbered opening across the board width, plus one extra.

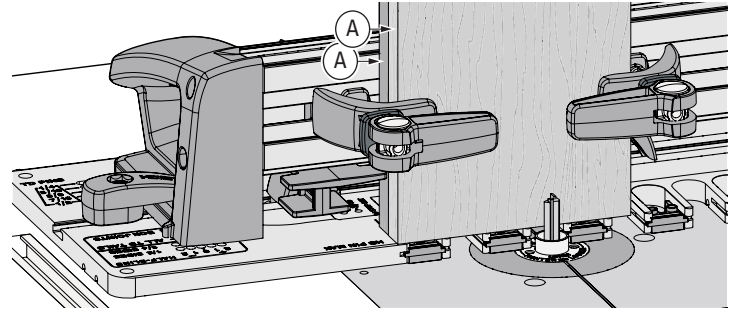

11-15 Quick Fit Test To save time and wood, clamp the two 1/2" thick **test** boards in the jig, back to back (A). **Review the remaining steps in this chapter.** Rout both boards at the same time and repeat again with frame in **No.2 BOX JOINTS** hole. Join the routed boards and make joint fit adjustments in the next three steps. Don't worry about board edge alignment, the test is for joint fit only.

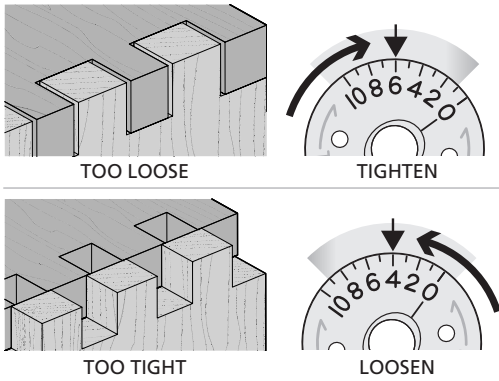

11-16 Test for Fit Keep the same side board edges together. If the joint is too loose, turn the eBush to a higher number, as shown in the next step. If too tight, turn the eBush to a lower number.

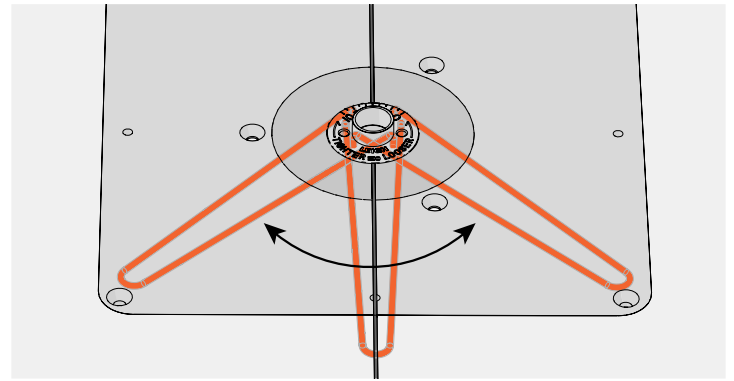

11-17 Each increment on the eBush changes the joint glue line fit by 0.002" [0.05mm]. Half an increment, a mere 1000th inch! **Re-tighten the eBush nut after each guide bushing adjustment.**

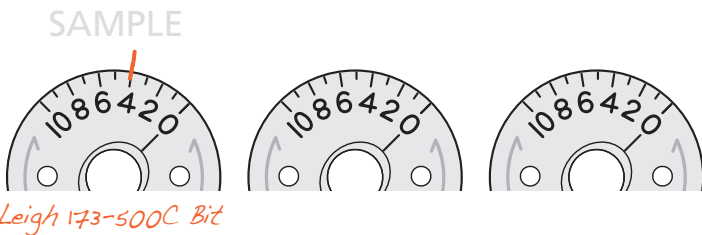

11-18 Record your settings here.

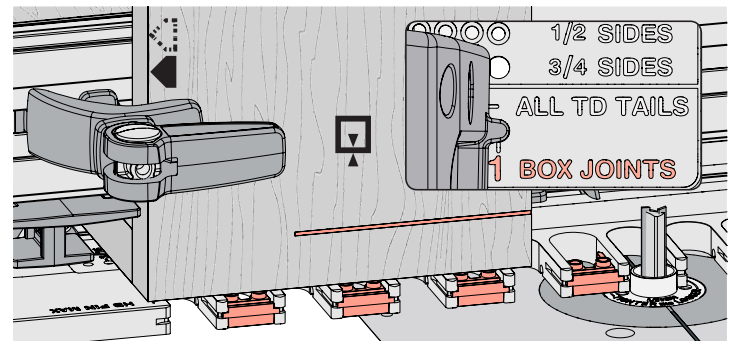

11-19 Now that your joint tightness has been determined, re-clamp socket board 1 in the jig, move the frame pin to the **No.1 BOX JOINTS** hole and latch frame.

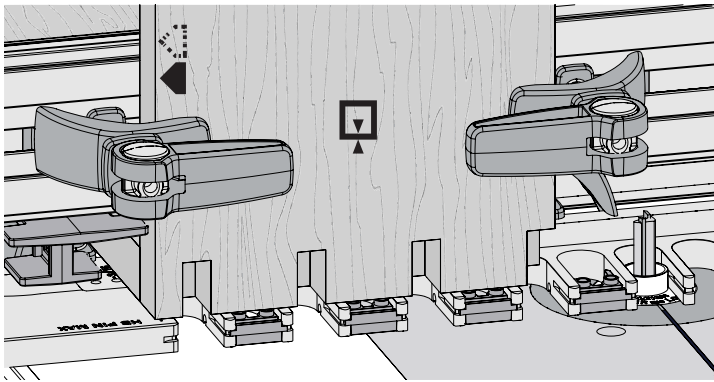

11-20 Rout into the first opening and every other template opening i.e. 1, 3, 5 and 7. **⚠ The eBush must touch one side of the opening as you enter and the other side as you exit. Do not remove the board or the backer board.**

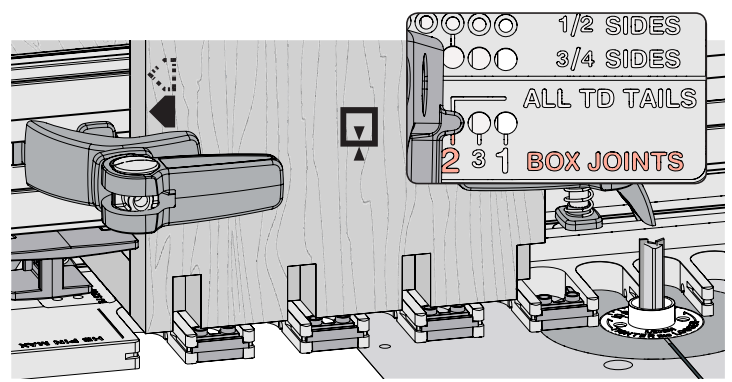

11-21 Loosen the latches and move the frame pin to the **No.2 BOX JOINTS** hole and latch the frame.

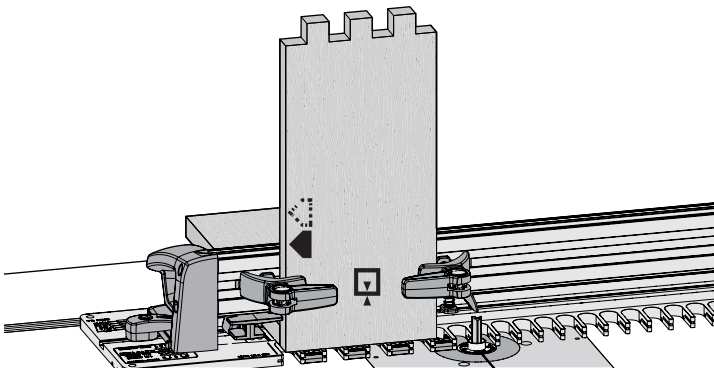

11-22 Again, carefully rout into the same sockets as before, i.e. 1, 3, 5, 7. Unclamp and flip the board, keeping the same edge against the side stop. Clamp the board and repeat the steps in reverse order. Remove socket board 1 and repeat steps 11-19 through 11-22 for socket board 2. Remove socket board 2.

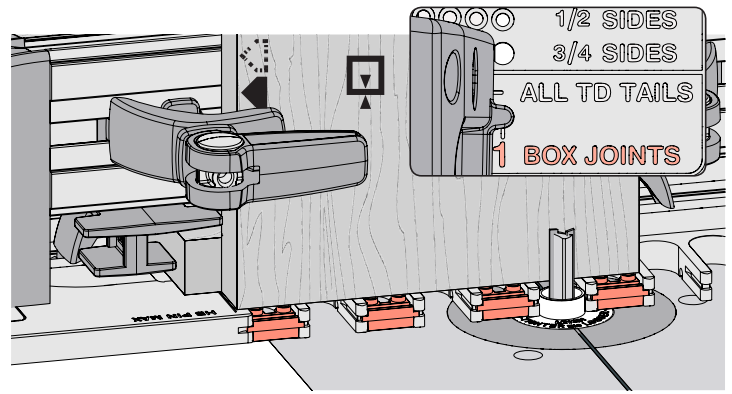

11-23 **Leave the frame latched and the backer board in place.** The right frame pin should be in the **No.1 BOX JOINTS** hole. Move the blockers to the odd numbered sockets. Clamp pin board 1 against the side stop.

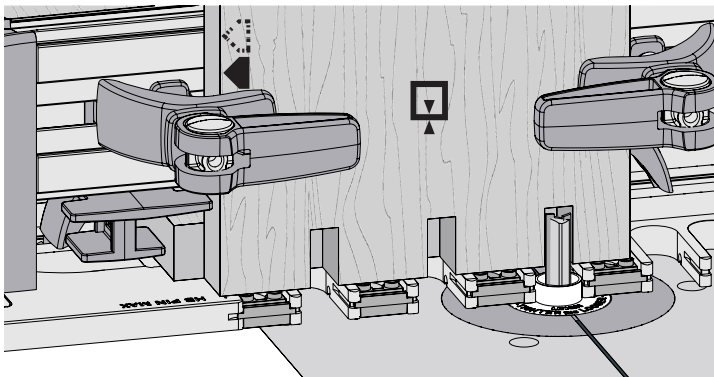

11-24 Now rout into the second and every alternating even numbered openings, i.e. 2, 4, 6, etc. **Do not remove the board, backer board or the blockers.**

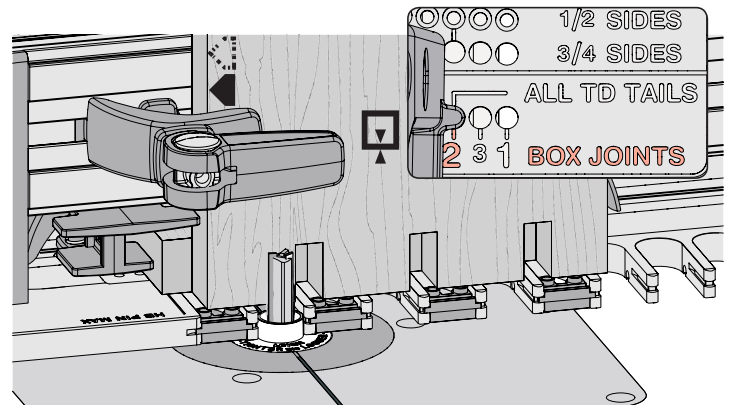

11-25 Move the frame pin to the **No.2 BOX JOINTS** hole and latch the frame. Rout into the same, even numbered sockets i.e. 2, 4, 6, etc. Unclamp and flip the board. Clamp the board and repeat the steps in reverse order. Repeat steps 11-23 through 11-25 with the second pin board. Remove socket board 2. All four boards are now complete and ready for assembly.

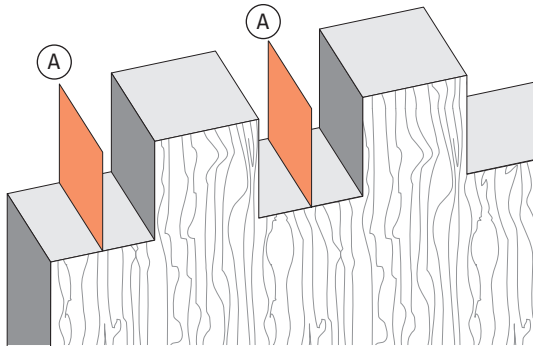

11-26 Theoretically, there will be nothing left in the sockets, where the bit has passed by twice. However, routing tolerances can leave a very thin “wall” **A**. This can be quickly removed with a chisel, file, or knife.

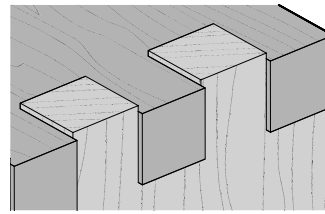

OVER FLUSH

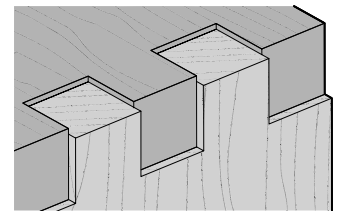

UNDER FLUSH

11-27 If the joint is over flush, lower the bit to suit. If the joint is under flush, raise the bit to suit. Rout a fresh test joint until fit and flushness are perfect before routing the actual workpieces. ■