

RTJ400 OPERATION

CHAPTER 10
3/8" Box Joints

3/8" Box Joints

3/8" Half-Blind Box Joints

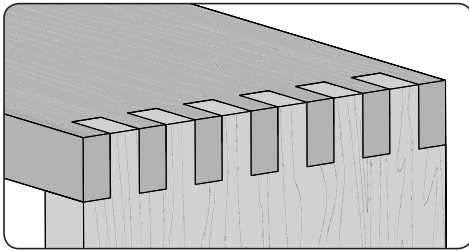

IMPORTANT SAFETY NOTE

Before using your Leigh RTJ400 you must have completed the preparatory steps listed in the previous pages, including reading the jig safety recommendations in Chapter 3.

3/8" Box Joints

10-1 Getting Started

Review the drawing below. **Symmetrical** joints have pins (A) on both edges of one board, and sockets (B) on both edges of the mating board. **Asymmetrical** joints have a pin (C) on one edge and a socket (D) on the other edge of each board.

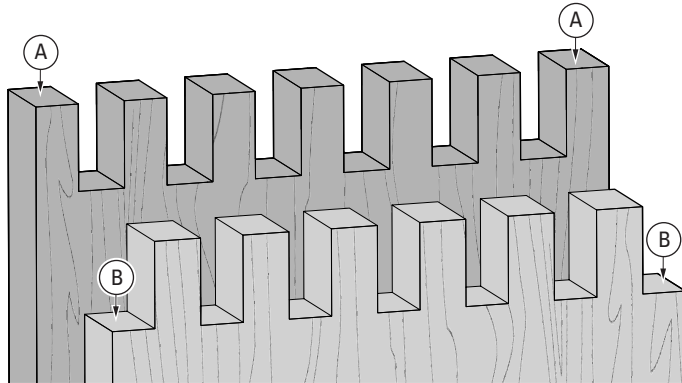

SYMMETRICAL

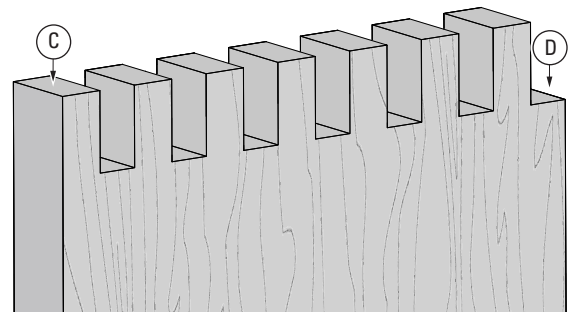

ASYMMETRICAL

10-2 Bits, Guide Bushing and Stop Rod

3/8" box joints are routed with the included 3/8" straight bit 143-500, or optional 173-500 or 173-500C bits, the e10 guide bushing (eBush), and the stop rod (for positioning the side stop only). They can be routed in board thicknesses up to the maximum capacity of the RTJ400 Template and the cutting depth of the bit, in this case, 1" [25.4mm].

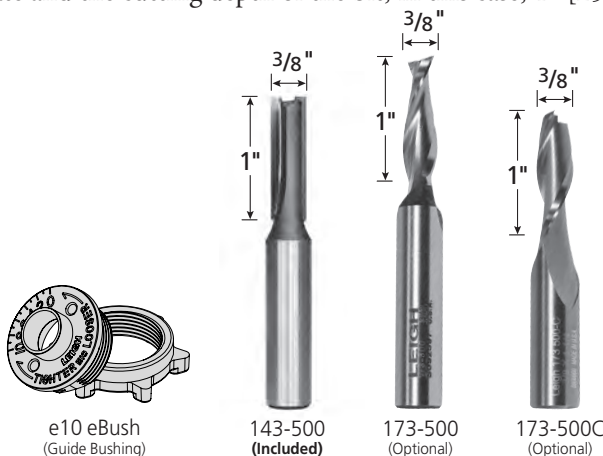

BOX JOINT BIT CUTTING DEPTH	
Bit Diameter	3/8"
Item No. Carbide Tipped	143-500
Item No. Spiral HSS (Optional)	173-500
Item No. Spiral Solid Carbide (Optional)	173-500C
Depth of Cut	0" -----
	1/4" -----
	1/2" -----
	3/4" -----
	1" -----

10-3 Board Width Selection

Board widths are determined by the total number of pins and sockets in the joint design and whether the joint is symmetrical or asymmetrical. Use this chart to determine board widths up to 16" [406mm].

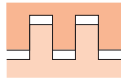

Symmetrical Joints have a full pin at each board edge. The total number of pins and sockets is always an odd number.

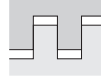

Asymmetrical joints have a full pin on one edge and a full socket on the other edge. The total number of pins and sockets is always an even number.

Symmetrical Board Width Chart for 3/8" Box Joints

Total Pins & Sockets	3	5	7	9	11	13	15	17	19	21	23	25	27	29	31	33	35	37	39	41
Inches	1 1/32"	1 15/16"	2 23/32"	3 1/2"	4 9/32"	5 1/16"	5 27/32"	6 5/8"	7 13/32"	8 3/16"	8 31/32"	9 3/4"	10 17/32"	11 5/16"	12 3/32"	12 7/8"	13 23/32"	14 7/16"	15 7/32"	16
Millimeters	29	49	69	89	109	129	148	168	188	208	228	248	267	287	307	327	347	367	387	406

Asymmetrical Board Width Chart for 3/8" Box Joints

Total Pins & Sockets	4	6	8	10	12	14	16	18	20	22	24	26	28	30	32	34	36	38	40
Inches	1 1/16"	2 11/32"	3 1/8"	3 29/32"	4 11/16"	5 15/32"	6 1/4"	7 1/32"	7 13/16"	8 19/32"	9 3/8"	10 5/32"	10 15/16"	11 23/32"	12 1/2"	13 9/32"	14 1/16"	14 27/32"	15 5/8"
Millimeters	40	60	79	99	119	139	159	179	198	218	238	258	279	298	318	337	357	377	397

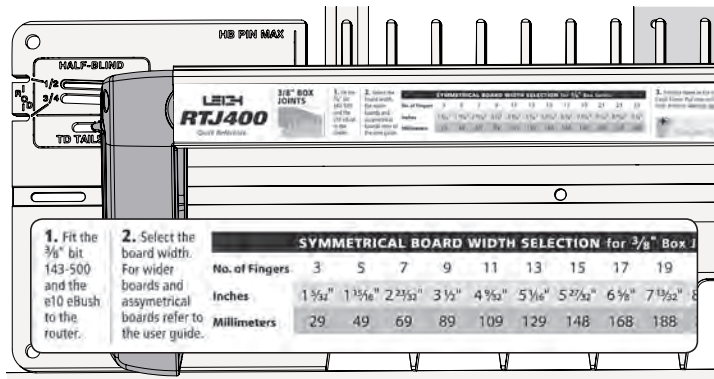

10-4 Use the Quick Reference strip to determine the correct straight bit and eBush combination.

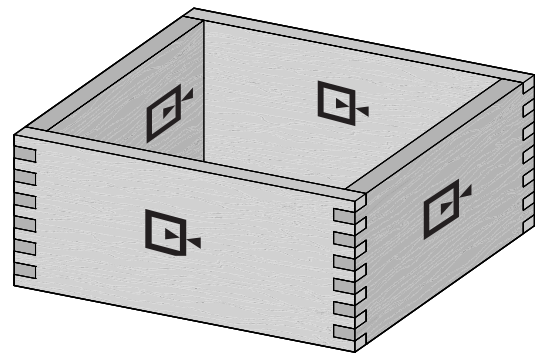

10-5 Making a Box Note the symbols indicating either side of the pin and socket boards can face in or out. With box joints, the same edge of the board goes against the side stop.

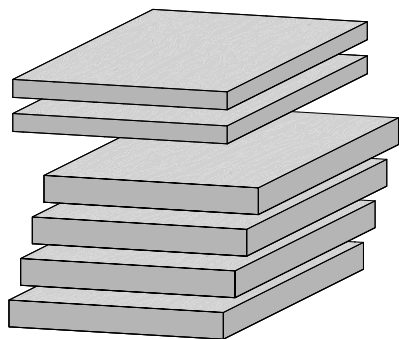

10-6 Prepare four similar boards 3/4" x 5 1/16" by about 12" long [19mm x 129mm x 305mm]. For the quick fit test you will need two test boards about 1/2" thick. Boards of different thicknesses may also be joined.

IMPORTANT: Read this whole chapter before routing any boards.

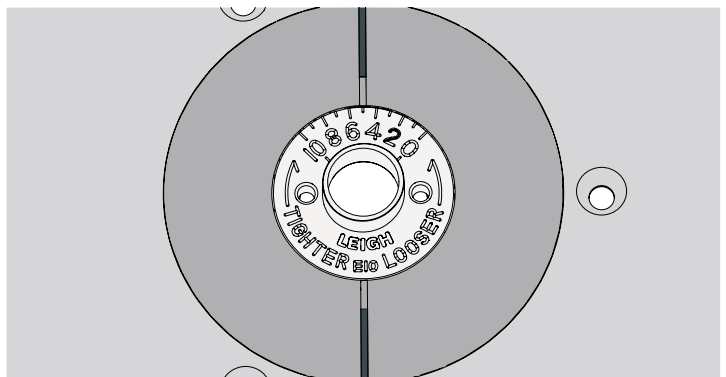

10-7 Fit the e10 eBush to the router table insert ring, set to 5.

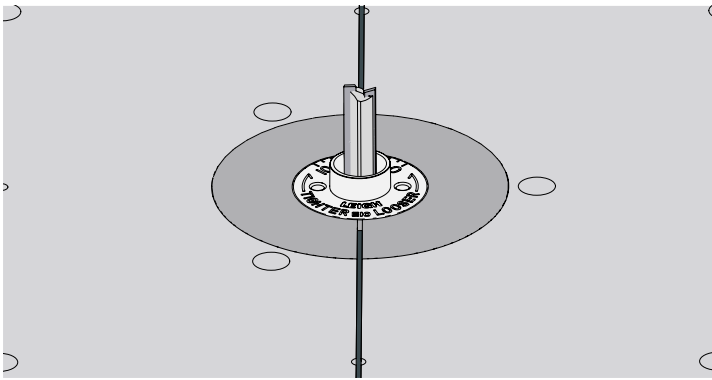

10-8 With the router unplugged, install the supplied $\frac{3}{8}$ " Leigh 143-500 bit. For cleaner routing use the optional $\frac{3}{8}$ " Leigh 173-500 (HSS) or 173-500C (solid carbide) spiral upcut bit, available at leighjigs.com. **⚠** Make sure the bit spins freely before connecting the power.

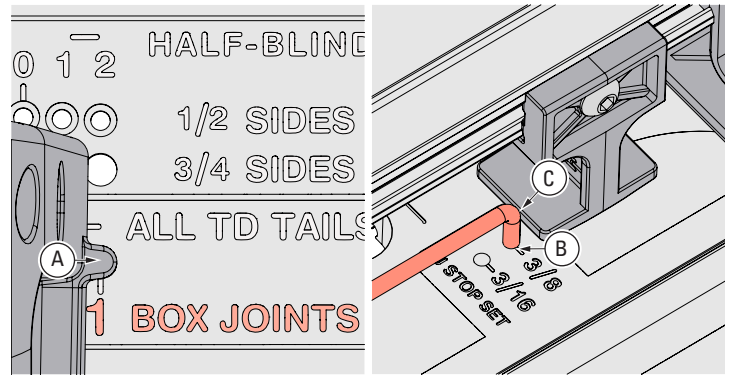

10-9 Insert the right frame pin in the **No.1 BOX JOINTS** hole (A) and the left frame pin in the **HALF-BLIND & BJ** slot. Latch the frame. Put the short end of the stop rod into the **$\frac{3}{8}$ " B J STOP SET** hole (B). Slide the side stop to lightly touch the rod (C) and tighten the side stop. Store the stop rod in the $\frac{3}{4}$ " slot.

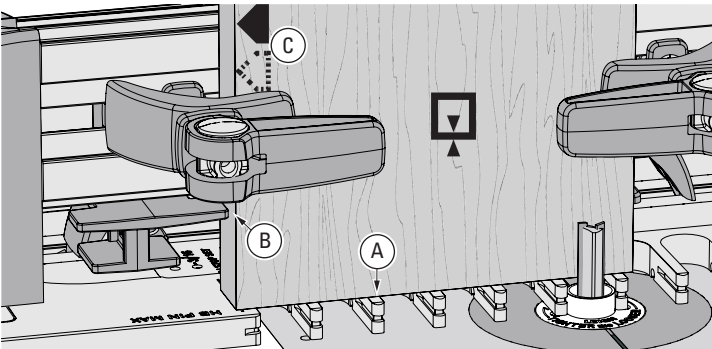

10-10 Clamp pin board 1 flush on the template (A) with the side edge against the side stop (B). **Always keep the same side edge of the board to the side stop when routing box joints (C).** If the board width is only slightly narrower than the chart width, center the board over the template, clamp in place and move the side stop against the board.

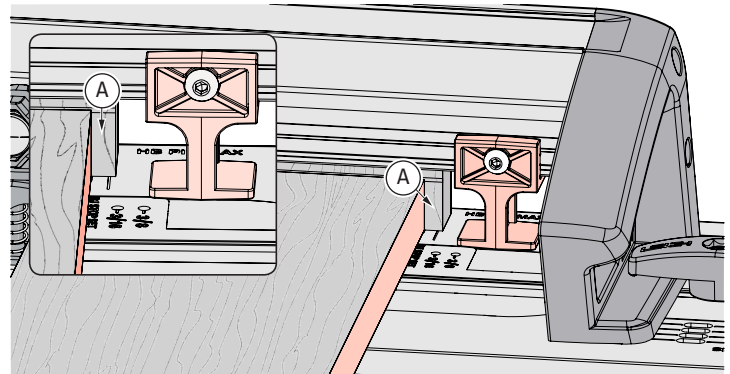

10-11 Position a backer board $\frac{1}{16}$ " [1.5mm] away from the edge of the pin board (A). This prevents the backer board from interfering with the side stop when the frame is repositioned in the second step. The backer board stays in place for the complete procedure. **Note: Clamp removed for clarity.**

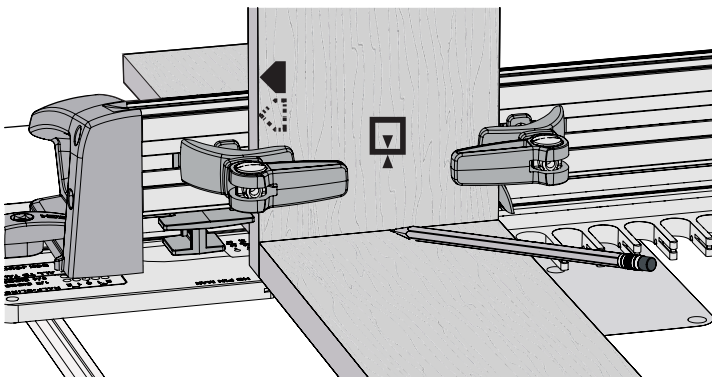

10-12 Place the end of a socket board on the template and pencil a line on the pin board.

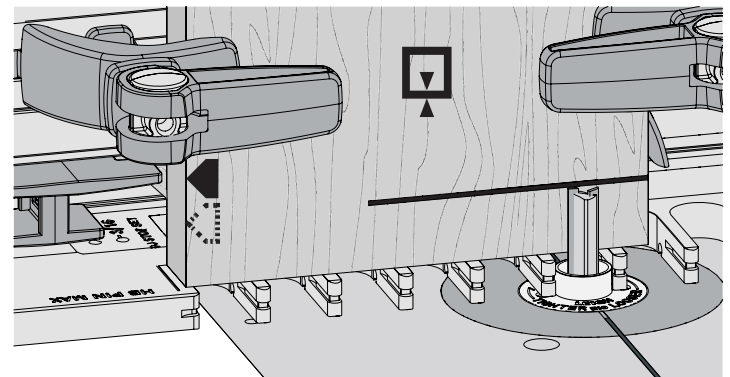

10-13 Adjust the bit to the center of the pencil line. **⚠** Double check that the bit still rotates freely. **IMPORTANT: Bit height determines the flushness of the joint, so set your bit properly the first time.** Adjustments for flushness are at the end of the chapter.

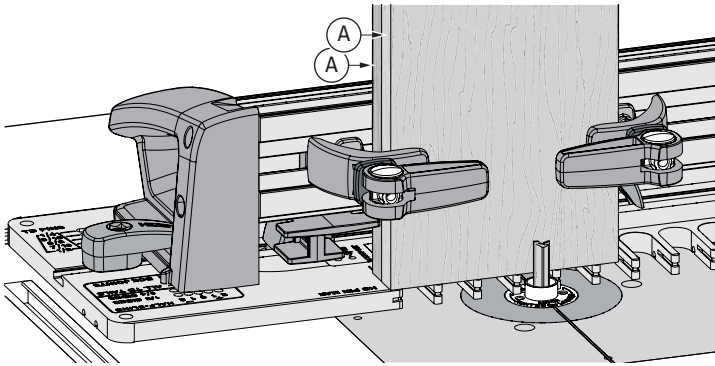

10-14 Quick Fit Test To save time and wood, clamp two ½" thick scrap boards in the jig, back to back (A). **⚠ First review the remaining steps up to 10-20.** Rout both boards at the same time. Test the boards for joint fit, and make joint fit adjustments (steps 10-15 to 10-17). Don't worry about board edge alignment, the test is for joint fit only.

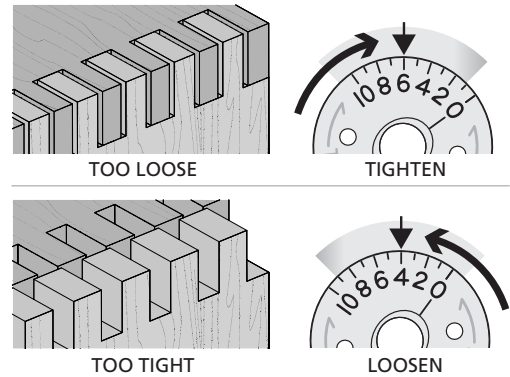

10-15 Joint Fit Adjustment Keep the same side board edges together. If the joint is too loose, turn the eBush to a higher number, as shown in the next step. If too tight, turn the eBush to a lower number.

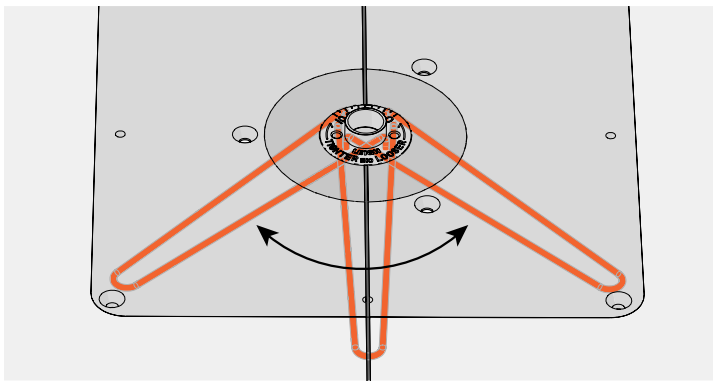

10-16 Each increment on the eBush changes the joint glue line fit by 0.002" [0.05mm]. Half an increment, a mere 1000th inch! **Re-tighten the eBush nut after each guide bushing adjustment.**

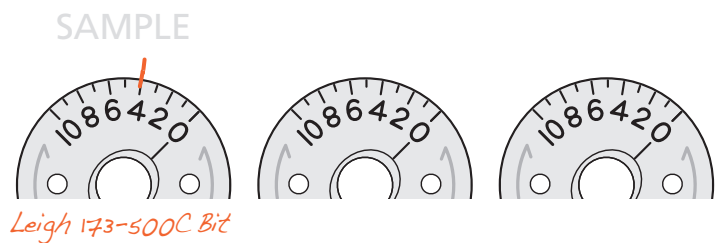

10-17 On the eBushes above, record the settings you used to achieve perfect joint fit. The first eBush is simply an example of how to record your setting.

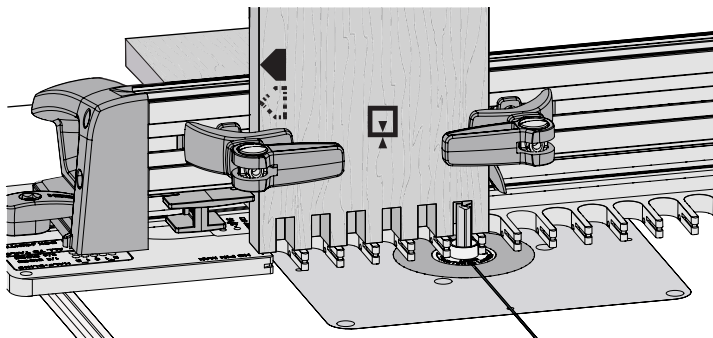

10-18 Now that your joint tightness has been determined, re-clamp pin board 1 in position and rout into all of the openings. **⚠ The eBush must touch one side of the opening as you enter and the other side as you exit.** Flip the board, keeping the same edge against the side stop, and rout the other end. Remove pin board 1 and repeat the procedure with pin board 2. Remove pin board 2.

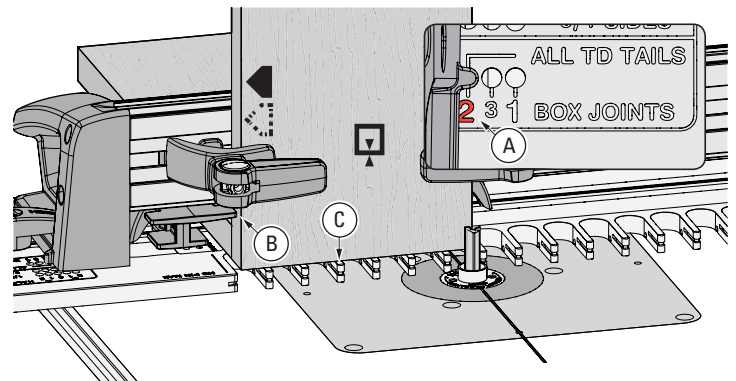

10-19 Unlatch and move the right frame pin to the **No.2 hole** in the **BOX JOINTS** mode (A). Latch the frame. Clamp socket board 1 against the side stop (B), flush on the template (C).

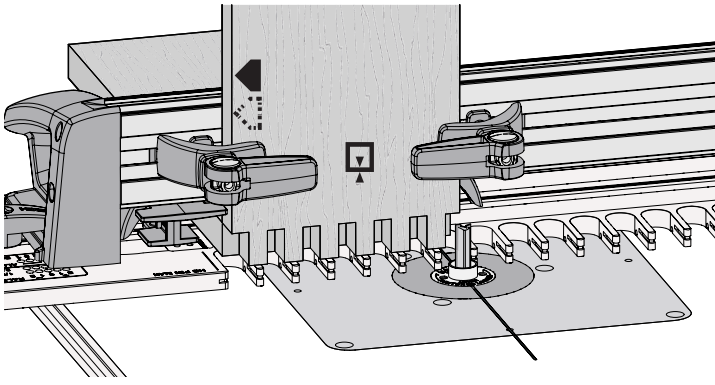

10-20 Rout the sockets making sure to contact both sides of each opening with the guide bushing. Flip the board and rout the other end. Repeat the procedure for socket board 2. All four boards are now complete and ready for assembly.

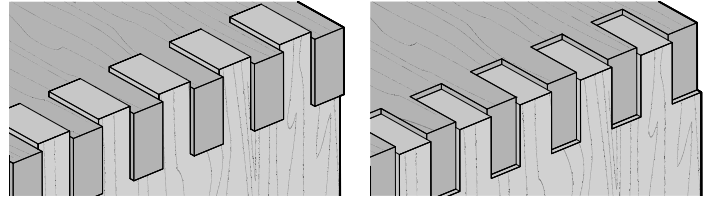

OVER FLUSH

UNDER FLUSH

10-21 Flushness If the joint is over flush, lower the bit to suit. If the joint is under flush, raise the bit to suit. Rout a fresh test joint until fit and flushness are perfect before routing the actual workpieces. ■

NOTE: See $\frac{3}{8}$ " Half-Blind Box Joints section on the next page.

3/8" Half-Blind Box Joints

10-22 Getting Started

Review the drawing opposite, to get a clear understanding of how the boards fit together and to learn the joinery terms.

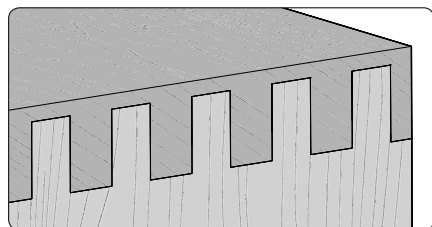
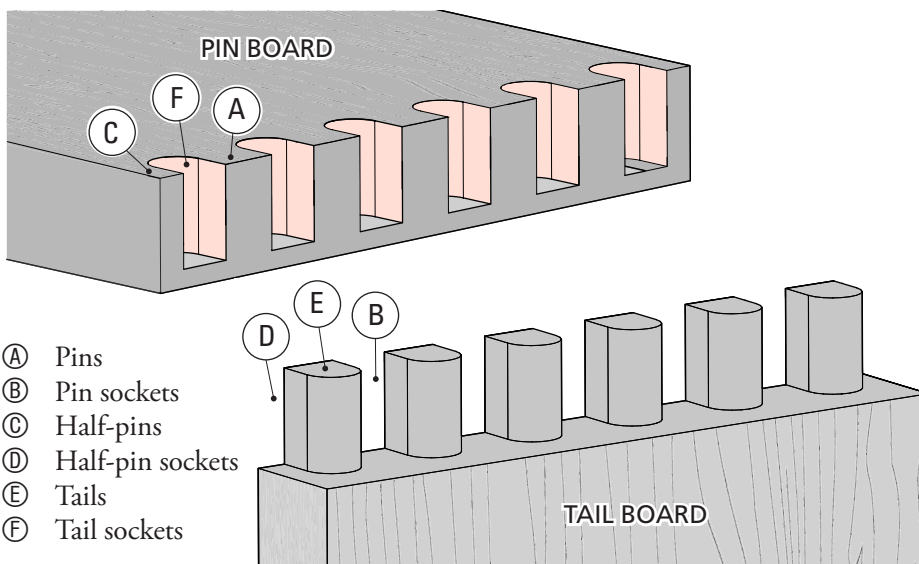

10-23 Bits, Guide Bushing and Stop Rod

To rout 3/8" half-blind box joints, use the included 3/8" straight bit 143-500 or optional 173-500 or 173-500C bits, the e10 guide bushing (eBush) and stop rod. They can be routed in board thicknesses up to the maximum cutting depth of the bit, in this case, 1" [25.4mm].



Stop Rod

e10 Guide Bushing (eBush)



143-500 (Included)

173-500 (Optional)

173-500C (Optional)

BOX JOINT BIT CUTTING DEPTH	
Bit Diameter	3/8"
Item No. Carbide Tipped	143-500
Item No. Spiral HSS (Optional)	173-500
Item No. Spiral Solid Carbide (Optional)	173-500C
Depth of Cut	0" -----
	1/4" -----
	1/2" -----
	3/4" -----
	1" -----

10-24 Board Width Selection

Half-blind box joints may be routed in boards up to 1" thick [25.4mm]. Use this chart to determine the best board width, up to a maximum of 16" [406mm]. Board widths are based on the number of full tails (A) in the joint design. Board edges always end with a half pin (B). Board widths in the chart below may be increased by 3/8" [6mm] or decreased by 1/8" [3mm] if required.

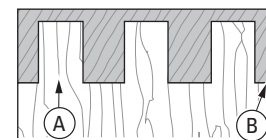

Board Width Selection for 3/8" Half-Blind Box Joints

No. of Tails	1	2	3	4	5	6	7	8	9	10	11	12	13	14	15	16	17	18	19	20	
Inches	Min	2 1/32"	1 7/16"	2 7/32"	3"	3 29/32"	4 9/16"	5 11/32"	6 1/4"	6 29/32"	7 11/16"	8 15/32"	9 1/4"	10 1/32"	10 13/16"	11 19/32"	12 3/8"	13 5/32"	13 15/16"	14 23/32"	15 1/2"
	Exact	2 5/32"	1 9/16"	2 11/32"	3 1/8"	3 29/32"	4 11/16"	5 15/32"	6 1/4"	7 1/32"	7 13/16"	8 19/32"	9 3/8"	10 5/32"	10 15/16"	11 23/32"	12 1/2"	13 9/32"	14 1/16"	14 27/32"	15 5/8"
	Max	1 1/32"	1 13/16"	2 19/32"	3 3/8"	4 3/32"	4 15/16"	5 23/32"	6 1/2"	7 11/16"	8 1/16"	8 27/32"	9 5/8"	10 13/32"	11 1/16"	11 31/32"	12 3/4"	13 17/32"	14 1/16"	15 3/32"	15 7/8"
Millimeters	Min	17	37	56	76	96	116	136	155	175	195	215	234	254	274	294	313	333	353	373	392
	Exact	20	40	60	79	99	119	139	158	178	198	217	237	257	277	297	316	336	356	376	395
	Max	26	45	65	85	105	124	144	164	184	203	223	243	263	282	302	322	342	361	381	401

3/8" Half-Blind Box Joints cont.

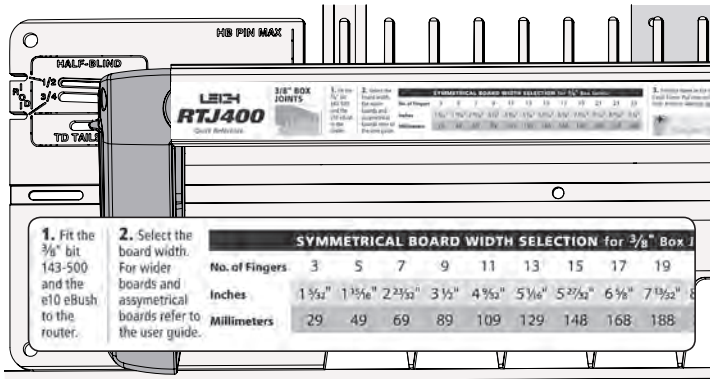

10-25 Half-blind box joints are made using the same bit and eBush as 3/8" box joints, however the **HALF-BLIND** section of the template is used.

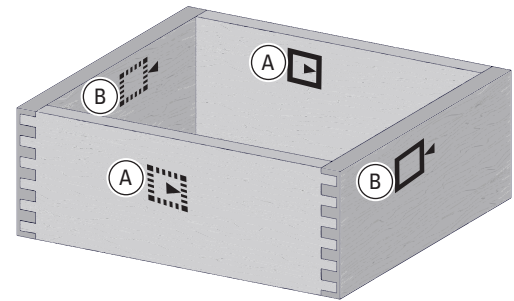

10-26 Note the symbols indicating the inside or outside of the pin and tail boards. To make a box you will need to mark these symbols on the inside faces of the tail boards (A) and outside faces of the pin boards (B).

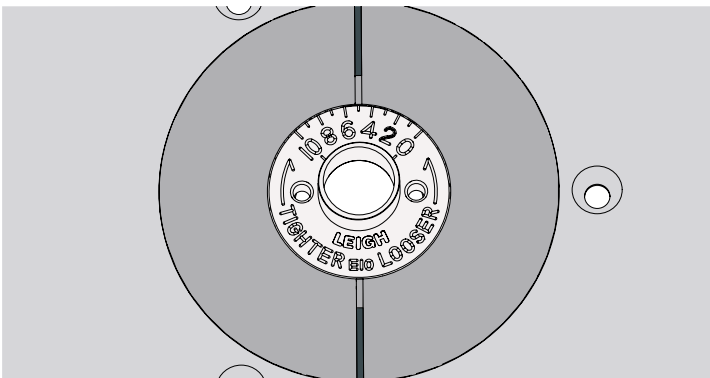

10-27 Fit the e10 eBush to the router table insert ring. If you have already determined the correct fit in the 3/8" box joint chapter, use that setting, or alternatively use the Quick Fit Test, Step 10-14.

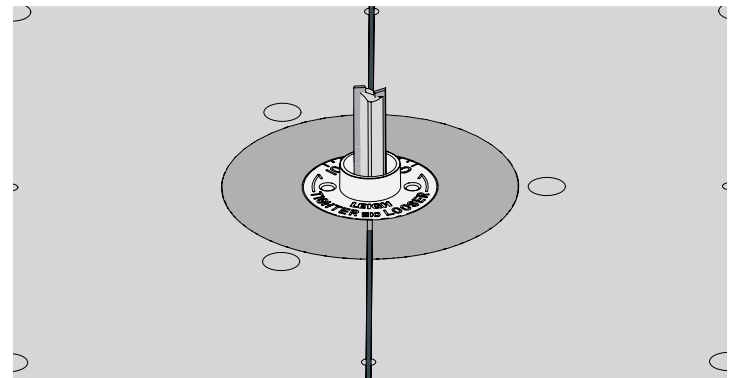

10-28 With the router unplugged, install the supplied 3/8" Leigh 143-500 bit. For cleaner routing use the optional 3/8" Leigh 173-500 (HSS) or 173-500C (solid carbide) spiral upcut bit, available at leighjigs.com. ⚠ Make sure the bit spins freely before connecting the power.

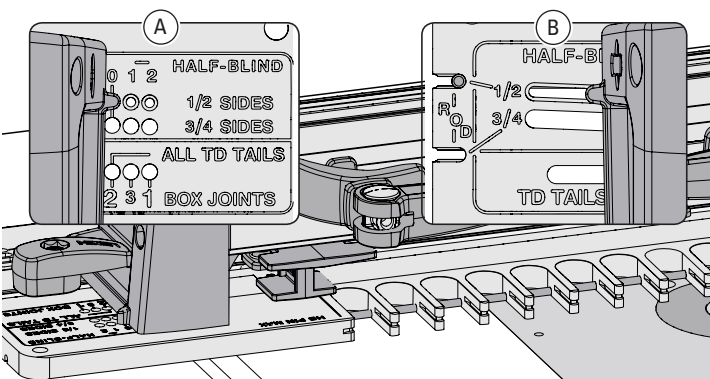

10-29 Insert the right frame pin in the 1/2" **HALF-BLIND** "0" pin hole (A) and the left frame pin in the 1/2" **HALF-BLIND** slot (B). Latch the frame. **Note: The HALF-BLIND pin hole settings refer only to the thickness of the pin board (drawer side).**

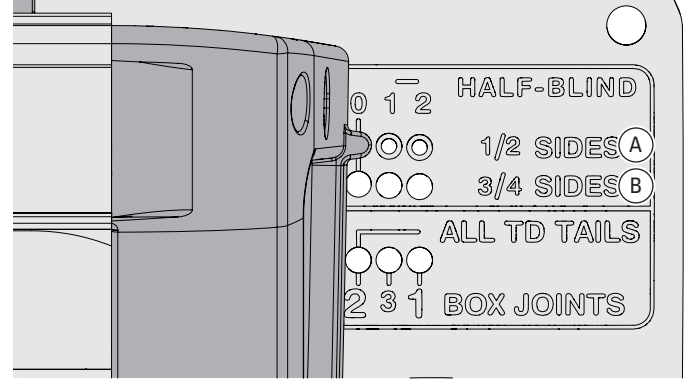

10-30 NOTE: Use the 1/2" row (A) for tail boards 3/8" [11mm] to 5/8" [16mm] thick, and the 3/4" row (B) for tail boards 1 1/16" [17.5mm] to 7/8" [22mm] thick.

3/8" Half-Blind Box Joints cont.

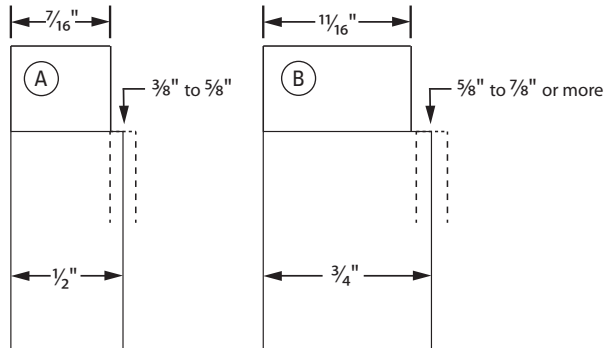

10-31 When the frame pin and stop rod are in the $\frac{1}{2}$ " positions, all tails will be $\frac{7}{16}$ ", dimension **A**, regardless of actual board thickness (dashed line). Similarly, when the frame pin and stop rod are in the $\frac{3}{4}$ " hole, all tails will be $1\frac{1}{16}$ ", dimension **B**, regardless of actual board thickness.

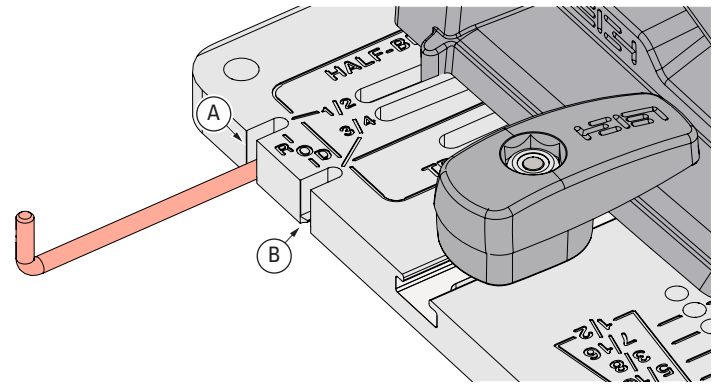

10-32 The Stop Rod. For tail boards from $\frac{3}{8}$ " [11mm] to $\frac{5}{8}$ " [16mm] thick, insert the stop rod in the $\frac{1}{2}$ " slot **A**. **Note: For tail boards $1\frac{1}{16}$ " [17.5mm] thick or greater, the stop rod is stored in the $\frac{3}{4}$ " slot **B**.**

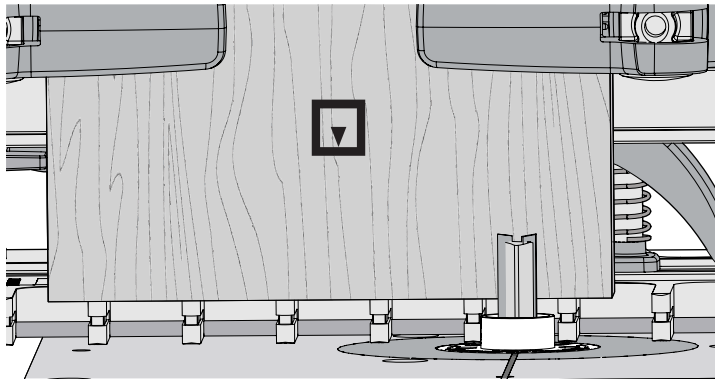

10-33 Center the tail board over the template so that the side edges are equally spaced over the template fingers and touching flush on the template. Clamp the tail board.

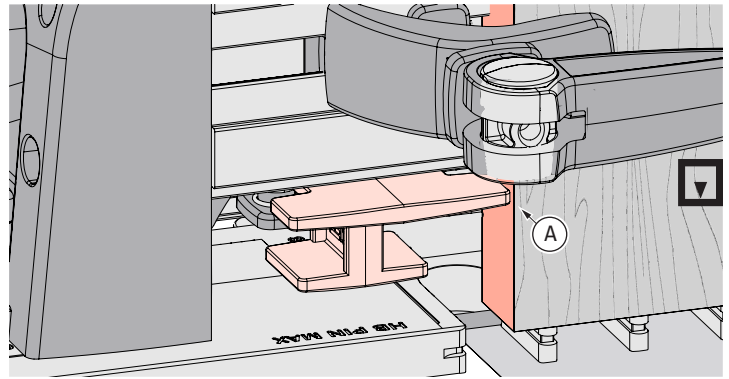

10-34 Slide the side stop so it lightly touches against the tail board and tighten it. **A**.

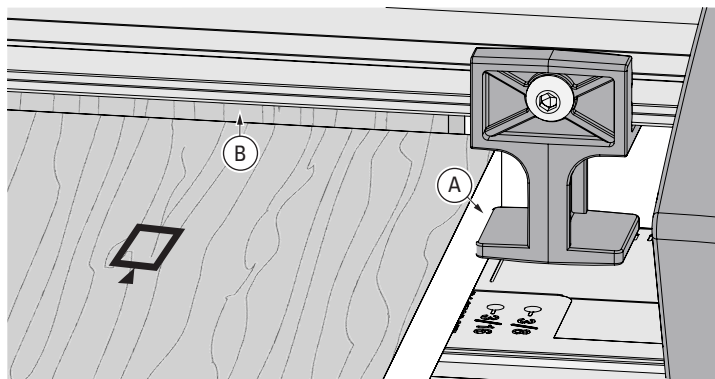

10-35 Position the pin board against the side stop **A** with the end edge touching **flush against the rear of the tail board** **B**, and clamp. **Note: Clamp removed for clarity.**

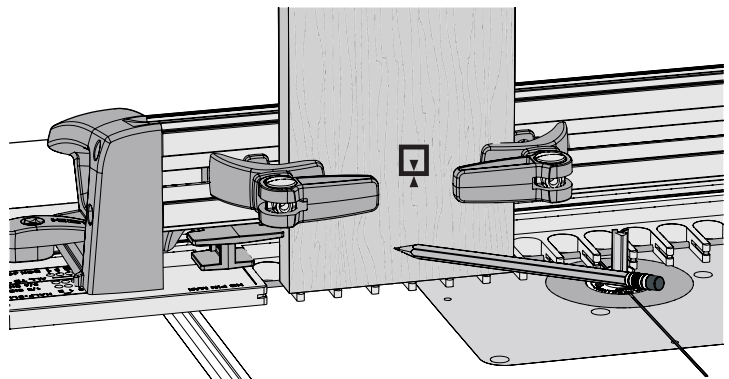

10-36 The depth of cut (how much the tail board intersects the pin board) is arbitrarily set. Our suggestion is to set the depth of cut about $\frac{1}{8}$ " less than the thickness of the pin board or in the case of lipped drawer fronts, slightly lower than the lip. In this case our pin board is $\frac{3}{4}$ ", so mark a line up from the end of the tail board $\frac{5}{8}$ ".

Half-Blind Box Joints cont.

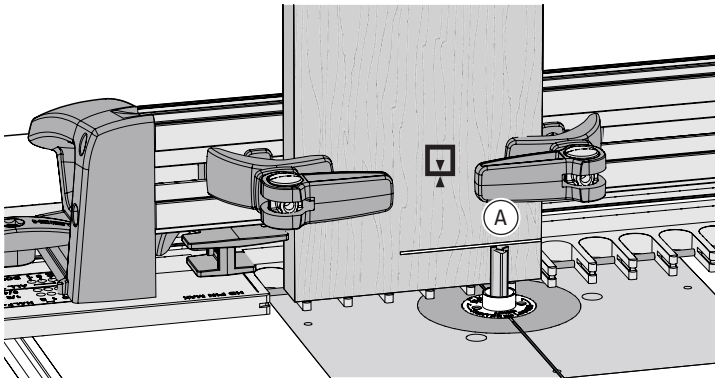

10-37 Adjust the bit to the center of the line (A).

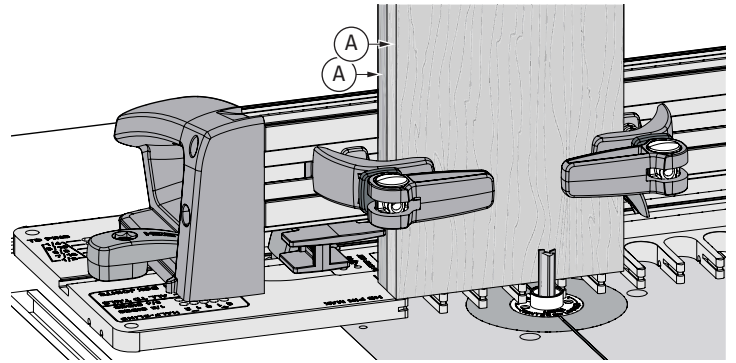

10-38 Quick Fit Test To save time and wood, clamp the two 1/2" thick scrap **test** boards in the jig, back to back (A). Rout both boards at the same time. Join the routed boards and make joint fit adjustments in the next three steps. Don't worry about board edge alignment, the test is for joint fit only. **Note:** If you have already done the Quick Fit Test in Step 10-17, use that eBush setting.

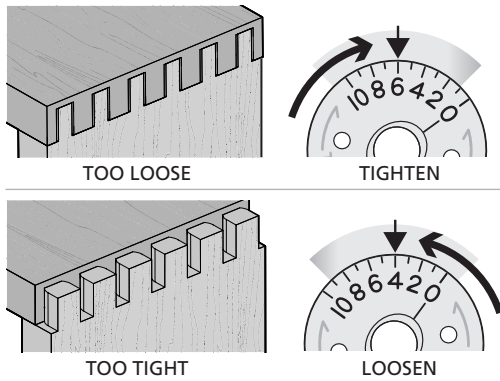

10-39 Test for Fit If the joint is too loose, turn the eBush to a higher number with the pin wrench as shown in the next step, and **rout two fresh boards**. If the joint is too tight, turn the eBush to a lower number and **rout two fresh boards**.

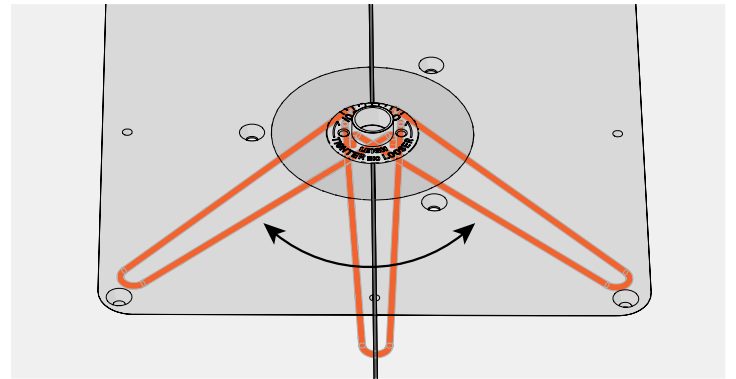

10-40 Each increment on the eBush changes the joint glue line fit by 0.002" [0.05mm]. Half an increment, a mere 1000th inch! **Re-tighten the eBush after each guide bushing adjustment.**

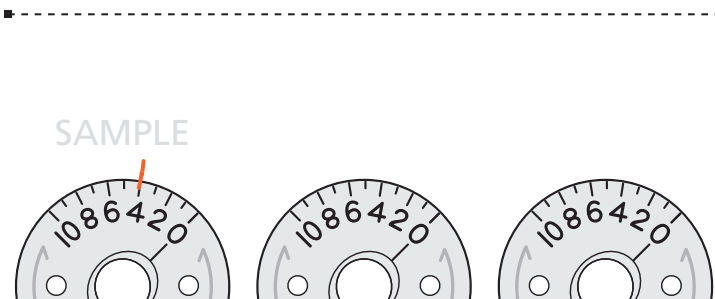

Leigh 173-500C Bit

10-41 Record your perfect fit eBush setting on one of the drawings provided above.

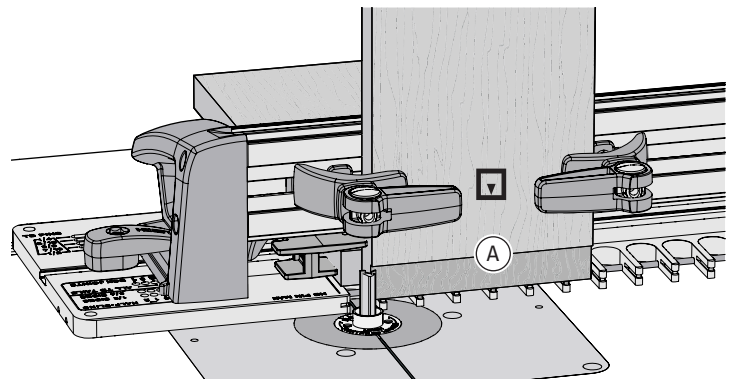

10-42 Re-clamp the tail board in position. Start by routing a very light, shallow climb cut, moving the jig right to left (A). This will leave a nice clean shoulder.

⚠ The bit will tend to drive the jig to the right, so make the cut light and with a firm grip.

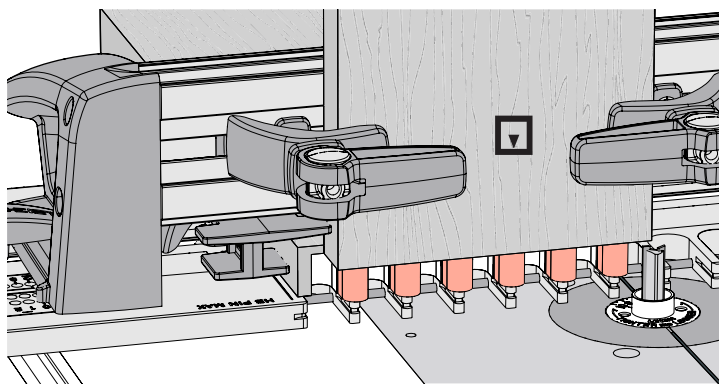
3/8" Half-Blind Box Joints cont.

10-43 Finish routing in and out of all template openings.
 ⚠ The eBush must touch one side of the opening as you enter and the other side as you exit.

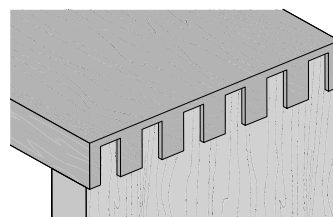

OVER FLUSH

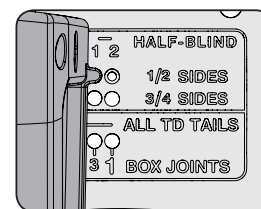

10-44 Flushness **IMPORTANT NOTE:** Do not adjust flushness until correct joint tightness in previous steps is achieved. For over flush tails, move the frame pin to a minus (“-”) tail position and rout a new test joint. ⚠ **You must re-center the tail board and reposition the side stop every time a reset for flushness is made.** Each pin position changes the joint flushness by 0.013"[0.33mm] Record the pin setting for future use.

Note: Tail board thickness will not affect flushness.

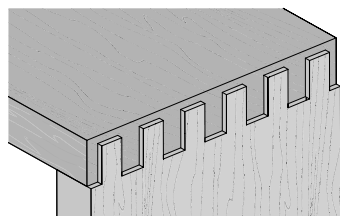

UNDER FLUSH

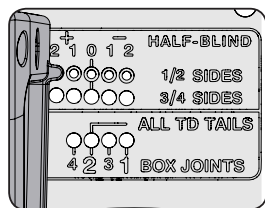

10-45 Flushness **IMPORTANT NOTE:** Do not adjust flushness until correct joint tightness in previous steps is achieved. For under flush tails, move the frame pin to a plus (“+”) pin position and rout a new test joint. ⚠ **You must re-center the tail board and reposition the side stop every time a reset for flushness is made.** Each pin position changes the joint flushness by 0.013"[0.33mm] Record the pin setting for future use.

Note: Tail board thickness will not affect flushness. ■