

LEIGH ISOLOC JOINT TEMPLATES User Guide

*I1A/B/C, I18B, I24A/B and I1600A/B/C Templates
for Leigh D-Series and SuperJigs Dovetail Jigs*

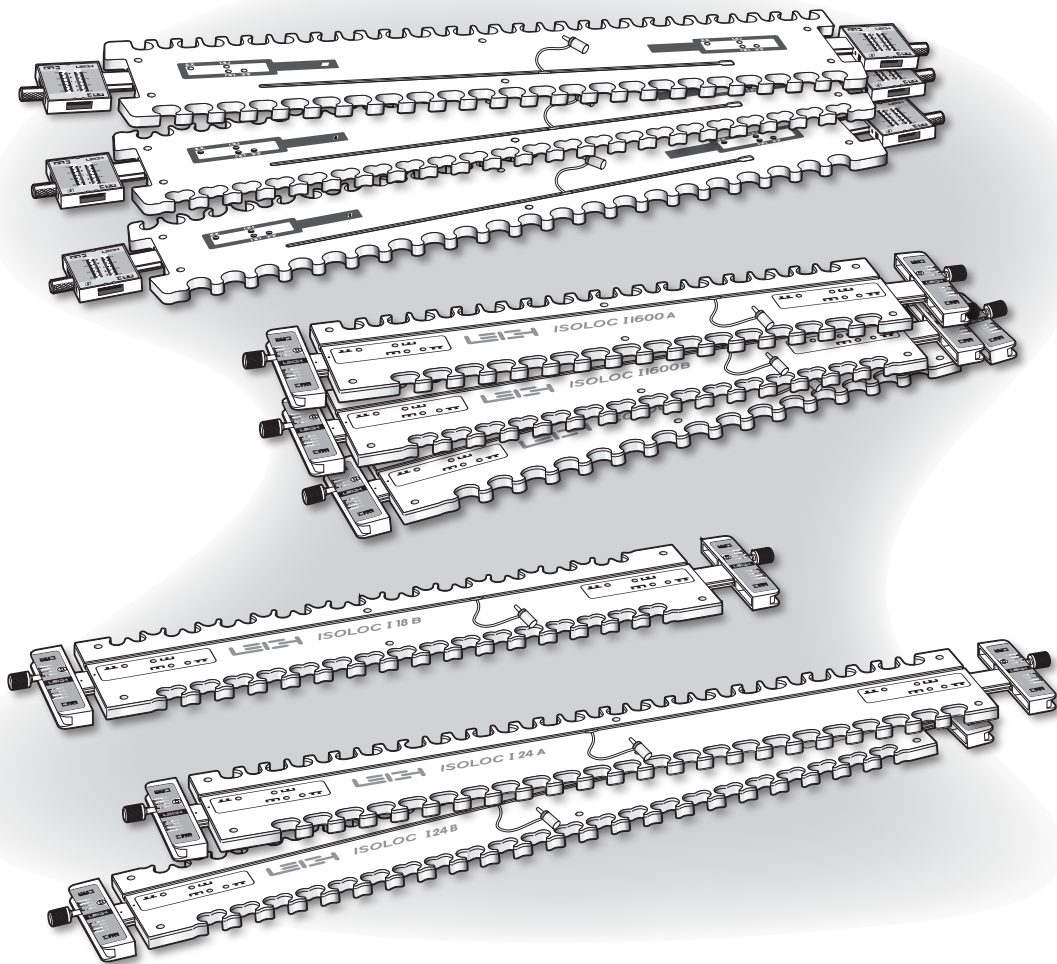

Dedicated Customer Support
1-800-663-8932

LEIGH
Joining Tradition with Today

Understanding Symbols and Terminology	1
CHAPTER1 - Mounting and Template Alignment	5
CHAPTER2 - Using Your Template Safely.....	11
CHAPTER3 - Operation Concepts & Basic Template Functions	13
CHAPTER4 - The Variable Guidebush System (VGS)	17
CHAPTER5 - Board Width Selection	19
CHAPTER6 - Half-Blind Isoloc Joint Procedures	23
CHAPTER7 - Rabbeted Half-Blind Isoloc Joint Procedures	29
CHAPTER8 - Inlaid Half-Blind Isoloc Joint Procedures	31
CHAPTER9 - Through Isoloc Joint Procedures.....	37
CHAPTER10- Isoloc Joint Symmetry and Asymmetry	39
CHAPTER11- Routing Procedures, Hints and Tips	41
AppendixI - VGS Guidebush and Bit Selection.....	45
AppendixII - Joint Specifications	49
AppendixIII- Template Parts List.....	51
AppendixIV Customer Support.....	55

Your New Leigh Isoloc™ Joint Template

The Leigh Isoloc* (equal locking) Templates and Variable Guidebush System (VGS)* are used on all 16" and 24" D-Series jigs, plus Super18" and Super24" jigs. They will allow you to rout uniquely beautiful half-blind corner joints, plus end-on-end, all with perfect fit thanks to the VGS.

This user guide is common to all Leigh Isoloc joint templates. Almost all illustrations show only the "A" template mounted on the D4 jig in the "Key" joint pattern mode. However, the joint icons ① are identical on all templates and all Isoloc templates work in exactly the same way ... regardless of the jig or template model. Note that the drawings in this user guide depict earlier model templates. The latest templates are engraved, with no decals ③.

The I1 template scales are different in shape than the I1600, I18 and I24 scales. Where scale readings are illustrated, the I1 scale will appear at the top ②.

Isoloc joint templates have dual inch and metric settings and may be used with either $\frac{5}{16}$ " or 8mm diameter bits. Only one variable guidebush (No. 713V; included) is required.

Carefully follow the mounting instructions for your jig model in the first section of the user guide. Then read the rest of the guide, following along with the basic functions. We suggest you rout some practice joints in scrap wood before you rout any precious hardwood work pieces.

Note: All operating references to D1600 jigs and I1600 templates throughout this guide apply equally to the I18 and I24 templates on Leigh Super Jigs.

If you have any questions that are not answered in the user guide, please call the Leigh customer support line. See Appendix IV – Customer Support.

* Leigh Isoloc joints, Isoloc templates, and Variable Guidebush System are protected by U.S., Canadian and European patents.

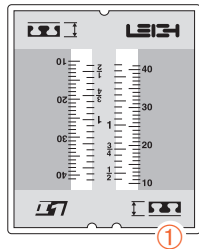

I1 Scale



I18, I24 Scale



Illustrated

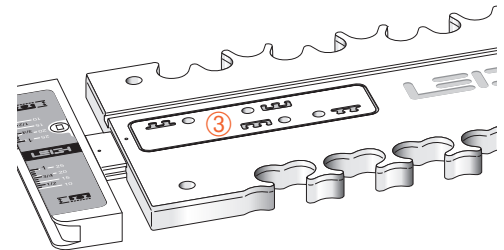

Engraved template

How to Read the Symbols

To help you understand the instructions and illustrations in this user guide, we have used a number of international symbols, plus a few special ones of our own. They are all explained below and are repeated frequently in the user guide, and you will soon get used to them.

There are three templates in the Isoloc Series. Each template has two Isoloc joint patterns for a total of six available joint shapes. Each template is identified by letter; A, B, or C ①, and each joint pattern is named in texts for reference, as below:

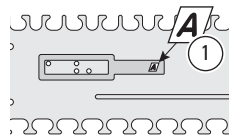

Only the Isoloc **A** “Key” template pattern is used in this user guide. Procedures for all other joints are similar.

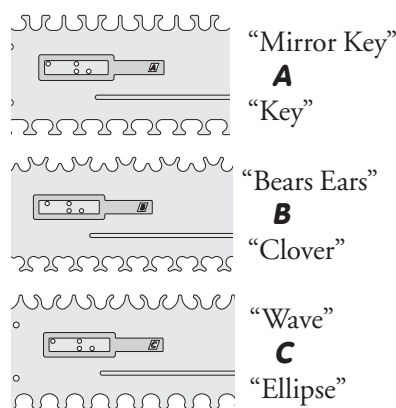

Scale Icons

 The scales all feature the same icon which (this way up) indicates the active scale.

Template Icons

 Indicates the template position for vertical pin boards.

 Indicates the template position for horizontal socket boards.

Isoloc Joint Terminology

It's a novel joint with a unique name, but we thought we would keep the joint part terminology simple. It is similar to typical dovetail terminology and should be easy to remember. Straight parts, cut in line with the grain are "pins" ①. Curved parts, cut across the grain are "sockets" ②.

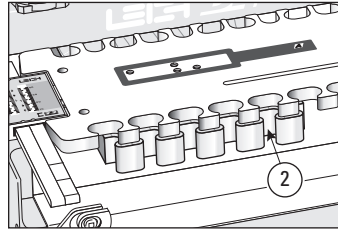
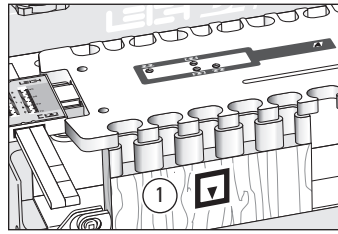

Which Way Round Should the Board Go?

Most joinery done on the Leigh Isoloc templates is for boxes. In nearly all the illustrations we have indicated which side of the board faces you when it is in the jig. *Note: On all Isoloc joint boards except end-on-end joints, the inside ▣ of the board faces away from the jig body.*

 Indicates the side of the board that will face outward.

 Dotted icons are on the other side of the board.

 Boards are clamped in the jig both "face in" and "face out" for alternate end cuts; e.g. all regular end-on-end Isolocs are routed this way.

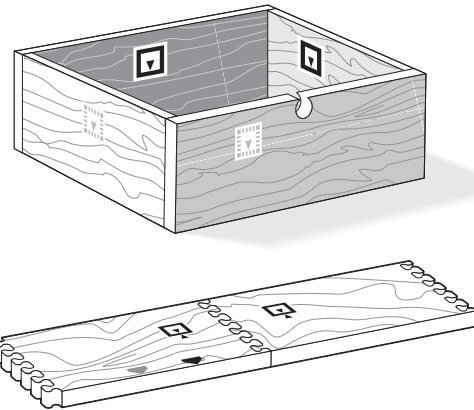

The following symbols indicate:

 This edge against side stop

 This edge against side stop

 As above, other side of board

 Caution: use special care for this operation

①②③ Numbered References in text

 Centreline of board or layout

 Plus/Minus

 Equals

 Does not equal

 Approximately

Mounting and Template Alignment

Assembly and Mounting

First, before you begin mounting your Leigh Isoloc template to your Leigh jig, make sure you have all the necessary parts.

1. **One only** complete Isoloc template assembly.
Make sure it is the model you ordered (see next page).
2. 1 User Guide
3. Variable Guidebush System consisting of:
 - 1 713V Guidebush
 - 1 700V Holder complete with lock ring
 - 1 Pin Wrench
 - 6 Bush Plugs (on one tree)
 - 1 Allen Key (for use on I1A, I1B and I1C Templates only)

If any of these items are missing from your order, please notify your supplier or Leigh Industries immediately.

Your Leigh Isoloc template comes fully assembled and requires only mounting and indexing to your Leigh jig body. **This procedure is critical to the accuracy of the finished joinery, so please follow the mounting instructions carefully.**

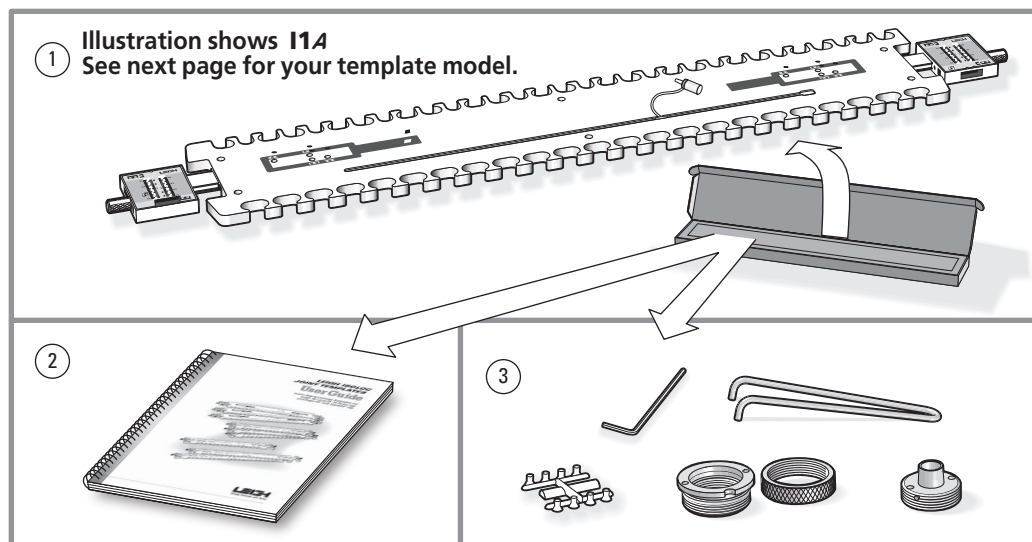

Check that you received one of the templates shown below:

I1

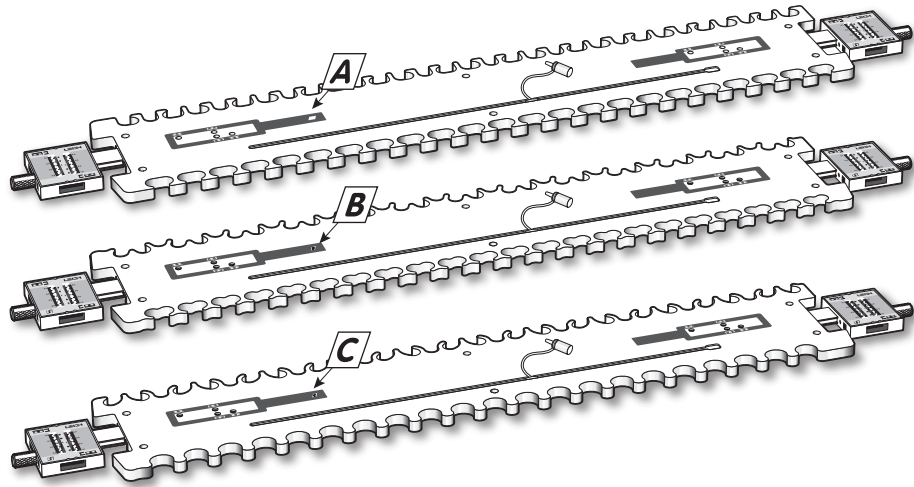

I1600

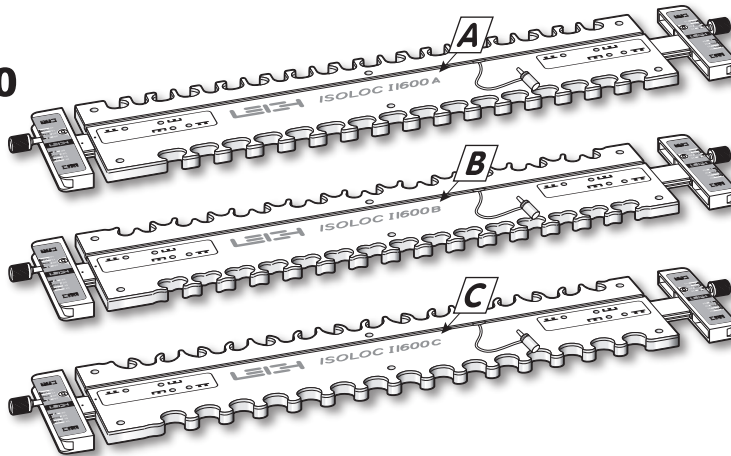

I18

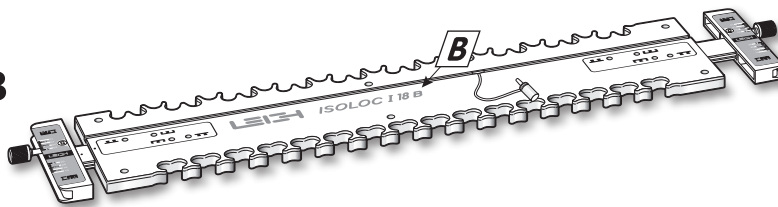

I24

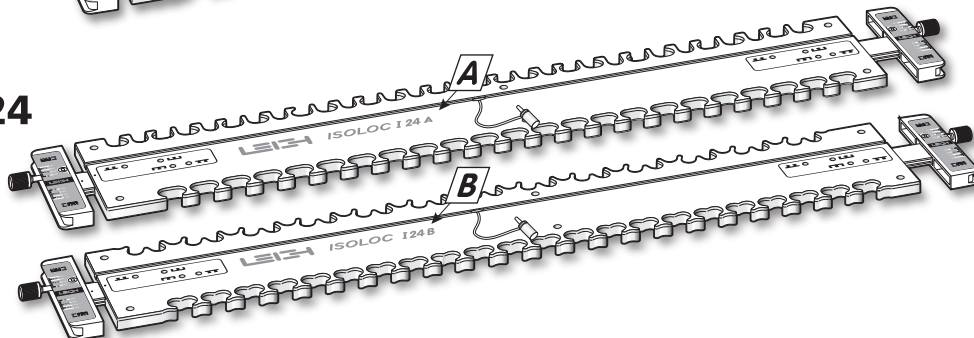

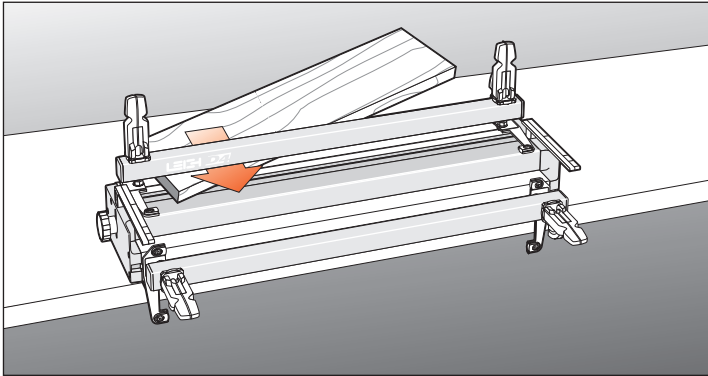

1-1 Mounting the 24" Template

For I1600, I18 and I24 Isoloc mounting go directly to 1-10. Mount the 24" D Series dovetail jig body firmly to a bench as per that jig's instructions. Clamp the spacer board into the rear clamp. The spacer board should be approximately 3/4" x 6" x 23"[20 x 150 x 575mm].

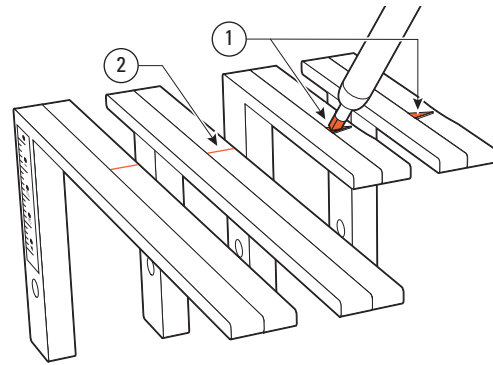

1-2 Support Bracket Markings D1258, D1258R and D3 jigs have short brackets marked with an 'arrow' for scale line-up. Shade the arrows with a black felt pen ① for better visibility. D4 and D4R jigs have either long or short brackets with lines ② in the correct location. Brackets supplied with the optional M2 or VRS systems may be used as is.

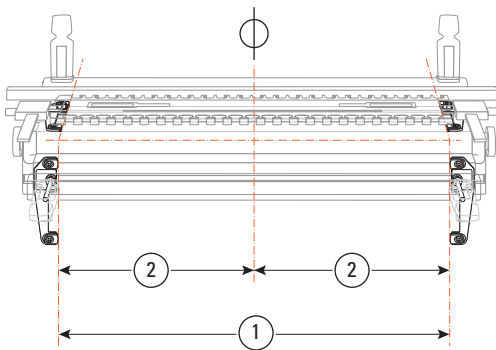

1-3 To ensure the accurate joints your Leigh Isoloc was designed to produce, check that the jig side stops are correctly positioned as per the original jig body instructions, i.e. 24 1/8"[613mm] apart ① and equidistant from the centreline ②. D4R side stops are machined as part of the body.

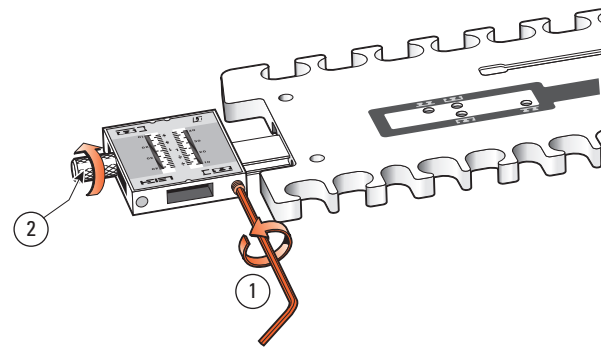

1-4 Loosen the two scale bar set screws ①, and the two scale thumb screws ② at both ends of the template.

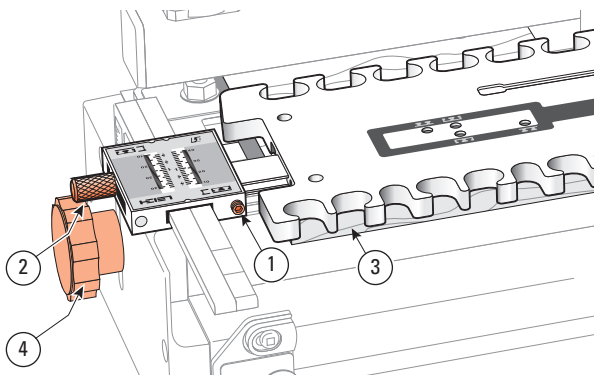

1-5 Slide the template assembly onto the jig support brackets with the set screws ① toward you and lower the completed assembly gently onto the spacer board ③. Tighten the support bracket knobs ④. **Do not tighten the set screws ①.** Make sure the scale reading is the same on both scales, say on the 1"[25mm] mark, then tighten the thumb screws ②.

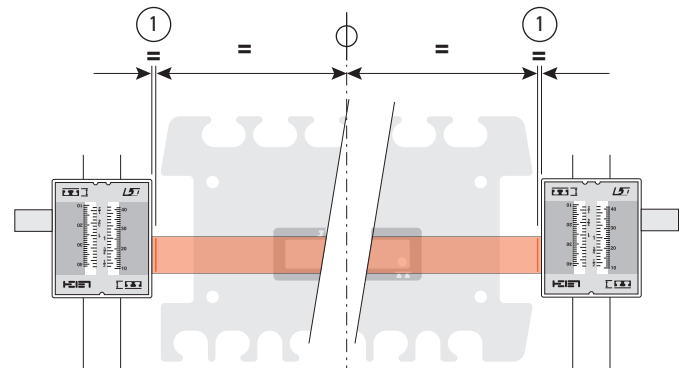

1-6 The template bar must now be centred between the two scale assemblies ①. The following instructions show how to do this.

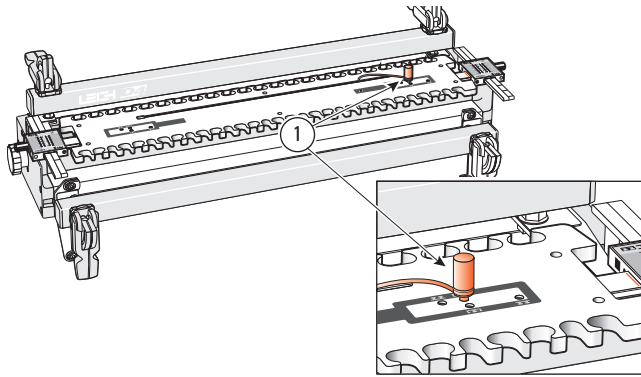

1-7 Discard the plastic shipping plug from its hole in the template. Move the template until you can insert the template pin through the rear right hand hole ① and into the bar.

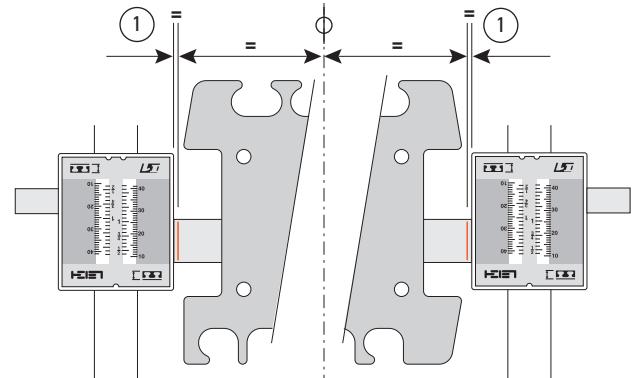

1-8 Move the template with its template bar left and right in the scales until the **scored lines at each end of the bar** are approximately equidistant from the scales ①. You can do this by eye; the human eye is an excellent comparator. If the gap appears the same, it is close enough. If you're more comfortable using a rule or dial caliper, by all means use it. *Note: The scored lines are illustrated in red for clarity.*

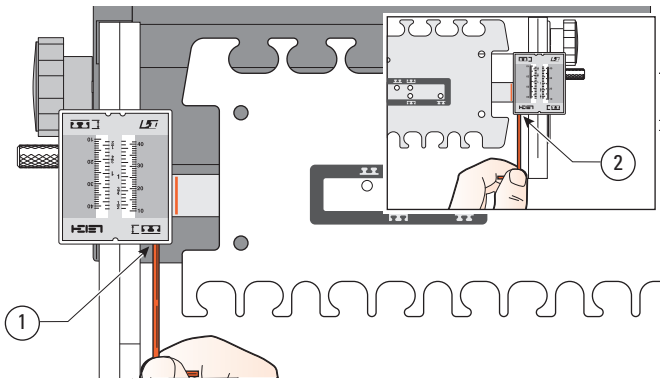

1-9 Taking care not to move the template and template bar, tighten first one scale bar screw ①, then the scale screw at the other end ②. The template bar is now centred.

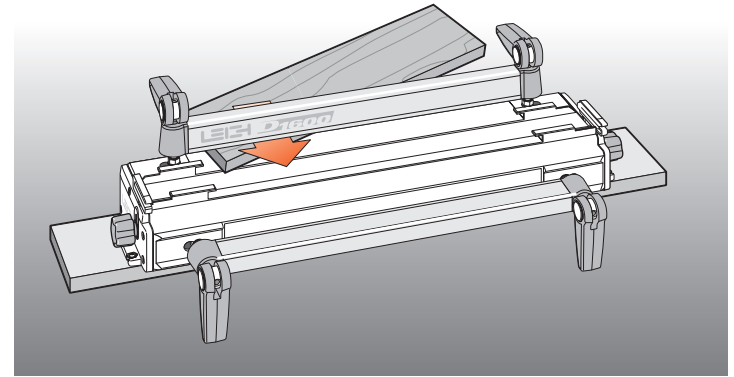

1-10 Mount a Superjig or D1600 jig body firmly to a bench as per that jig's instructions. Clamp the spacer board into the rear clamp. The spacer board should be approximately $\frac{3}{4}$ " x 6" [20 x 150mm] x 1" [25mm] less than jig length.

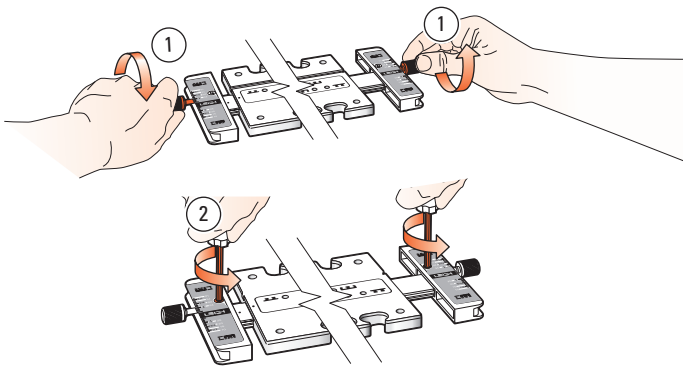

1-11 Mounting I1600, I18, and I24 Isoloc Templates
Install the two thumbscrews a few turns into the scales ①. Loosen the scale lock screw ② at **both** ends (by one turn only).

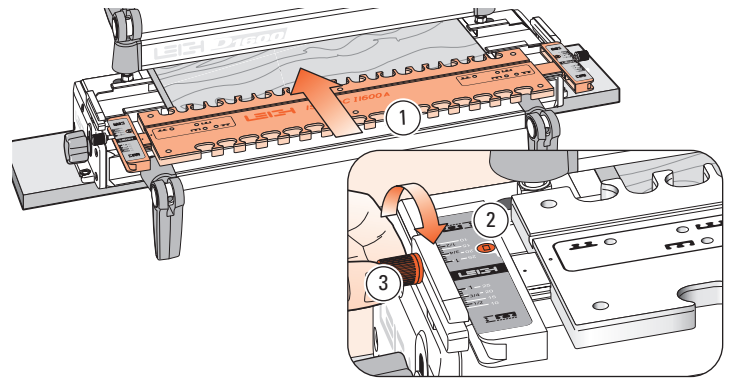

1-12 Slide the finger assembly onto the support brackets, in the "single" joint pattern (key, clover or ellipse) to the front ① and the scale lock screw to the rear ② and set on $\frac{3}{4}$ " [20mm]. **Tighten both thumbscrews ③.**

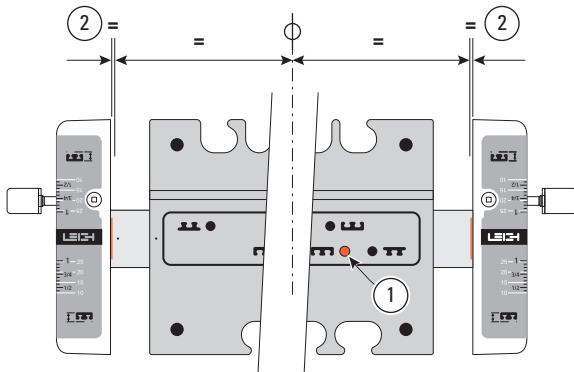

1-13 Lower the template onto the spacer board. Discard the plastic shipping pin from its hole in the template. Move the template until you can insert the steel template pin through the right front hole ①. Move the assembly left and right until the scored lines ② (illustrated in red for clarity) at each end of the template bar are about equidistant from the scales. You can do this by eye. If the gap appears the same, it is close enough. If you are more comfortable using a rule or caliper, by all means use it.

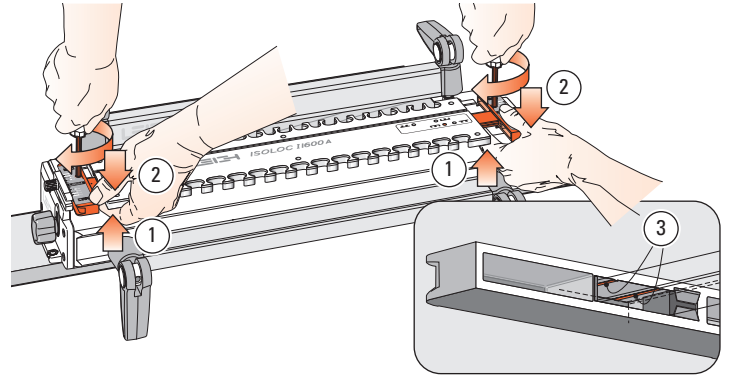

1-14 Taking care to not move the template, pull up on the template bar ① while pushing down on the scale ② to ensure the bar is touching the two registration pads ③ inside the scale. Maintain pressure and tighten the scale lock-screw. Repeat at the other end. The template is now centred.

To maintain correct assembly alignment, follow this procedure whenever you remove the scales from the template assembly. ■

Using Your Template Safely

Safety is not optional.

Read and follow the recommendations in this chapter.

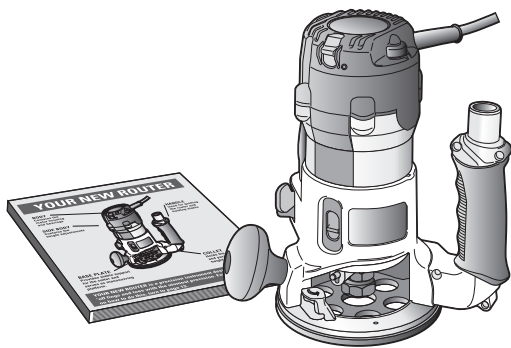

2-1 Read the owner's manual that came with your router. It is essential to understand the router manufacturer's instructions completely.



2-2 Most importantly, always wear approved safety glasses when using a router.

Always wear hearing protection when using a router.

Protect yourself from harmful dust by wearing a face mask.



2-3  Never drink alcohol or take medications that may cause drowsiness when you will be operating a router.

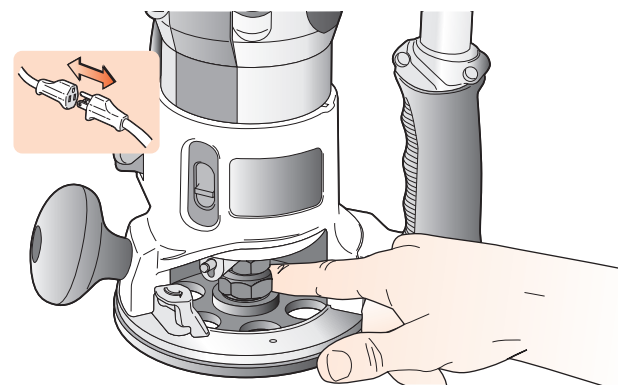

2-4 Always disconnect the power source from the router when fitting bits or guidebushes, or making adjustments.

Before connecting the router to the power source, make sure the bit and collet revolve freely in all the areas you plan to rout, and the bit does not touch the guidebush or jig.

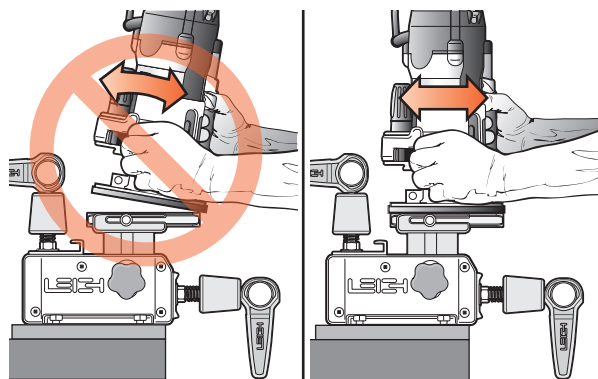

2-5 Do not tilt the router on the jig.
Keep the router flat on the jig assembly.

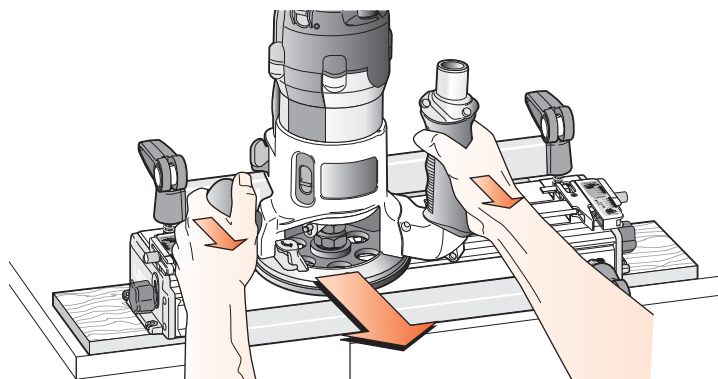

2-6 If you insist on removing the router from the jig while it is still revolving, always pull it straight off the jig horizontally, and do not raise or lower the router until it is completely clear of the jig.

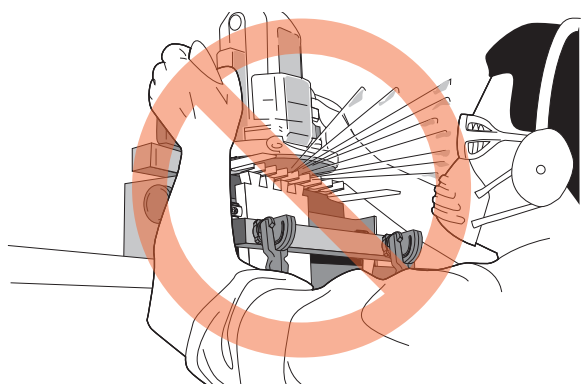

2-7 Do not rout at face level.

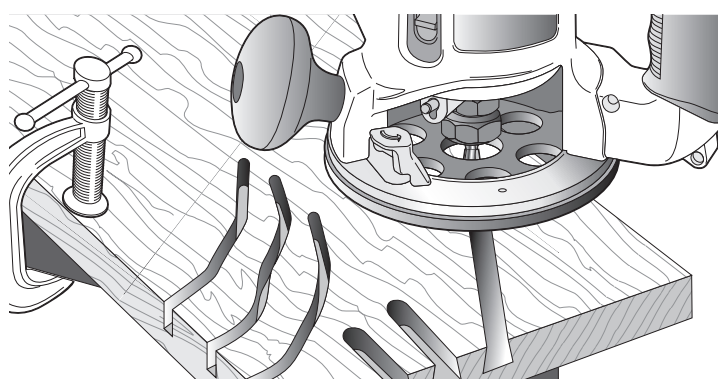

2-8 If you have never used your router before, be sure to follow the router manufacturer's instructions for its use. Make plenty of simple open-face practice cuts *without a guidebush* before you try to use the router on the Leigh jig. You must, of course, always use a guidebush when routing on the Leigh Jig. ■