

ATTENTION D4R Jig Owners.

F1 Template Assembly, Mounting and Template Alignment

This addendum replaces all of Chapter 1 of the F1 User Guide when using the new Leigh D4R Jig Body.

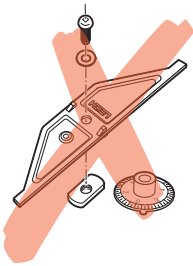

! Note: These parts are no longer required for setting up the F1 Template. They are not included with the Template package, and can be ignored if you already received them with your jig.

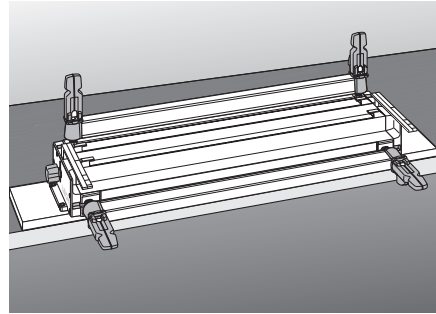

1 Mount the D4R jig firmly to a bench as per its instructions. Remove the dovetail finger assembly.

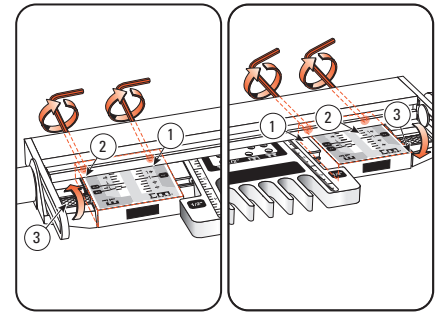

2 Loosen the two scale bar set screws ①, the two fence bracket screws ②, and the two scale thumb screws ③ **at both ends** of the template.

© Leigh Industries Ltd. All rights reserved.

This pdf publication may be downloaded and stored on a computer and printed, viewed, and freely distributed for operational guidance and evaluation purposes. This document supplements the full User Guide publication for the Leigh tool and may refer to and depend on information in other parts of the tool's User Guide for completeness. Except as provided herein, no part of this document may be reproduced, sold, published or modified without the prior written permission of Leigh Industries Ltd. [Nov2005]

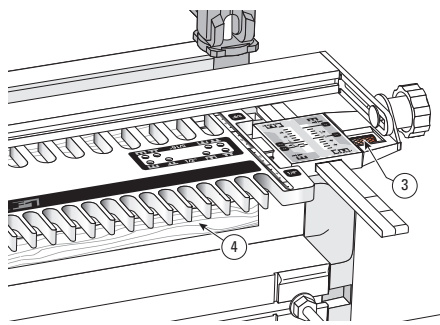

3 Slide the template assembly onto the jig support brackets with the 1/2" and 1/4"[10 and 8mm] combs toward you and lower it gently onto the D4R jig's spacer board ④ (D4R UserGuide 1-1). Make sure the scale reading is the same on both scales, say on the 1"[25mm] mark, then tighten the thumb screws ③.

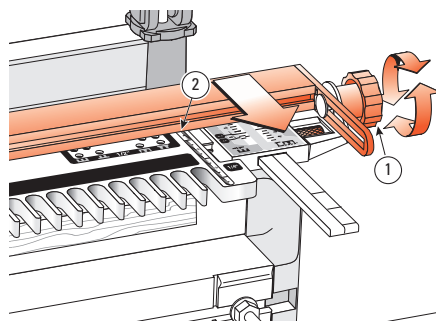

4 Loosen the fence knobs ① and move the fence on the template toward you as far forward as possible and with the fence scale reading the same at both ends ②. Then tighten the fence knobs ①.

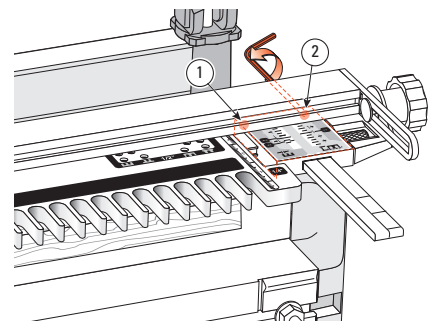

5 Tighten the scale bracket screws ②, but do **not** tighten the scale bar screws ① yet.

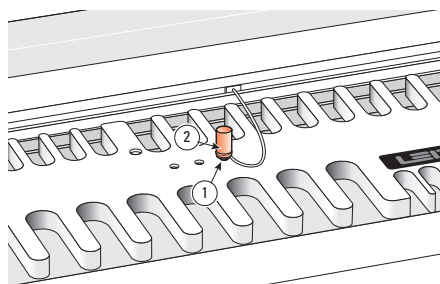

6 Discard the plastic shipping plug from the centre hole. Align the template so that the right hand hole ① of the three central template holes aligns with the hole in the bar. Insert the template pin ②, gently twisting and pushing the tapered pin into the hole until it is fully seated.

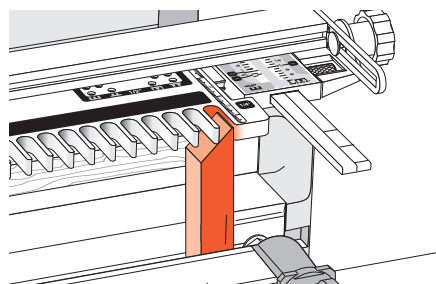

7 Trim off the end of a perfectly straight block at about 30 degrees. Slide the combined bar/template to allow the block to protrude into the last socket of the 1/4"[8mm] comb. Clamp the block with its vertical edge tight against the right hand side stop.

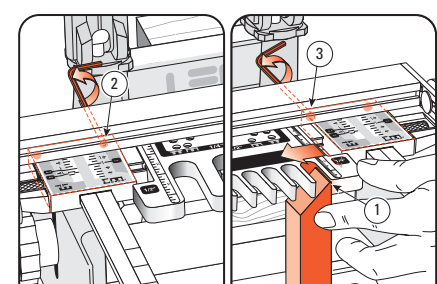

8 Move the combined template and bar to the left until the right side of the outer 1/4"[8mm] opening touches the block ①. Taking care to not move the template assembly, tighten the scale screws at the left end ②. Remove the block. Remove the pin and slide the template left. Tighten the scale screw at the right end ③. Your Leigh F1 is now ready for use. ■

ATTENTION D4, D3, D1258 Jig Owners.

**F1 Template Assembly,
 Mounting and Template Alignment**

This addendum replaces all of Chapter 1 of the F1 User Guide when using the classic Leigh D4 Jig Body.

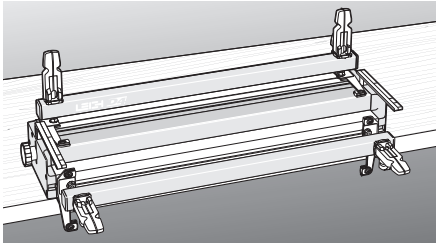

1 Mount the D4 jig firmly to a bench as per its instructions. Remove the dovetail finger assembly.

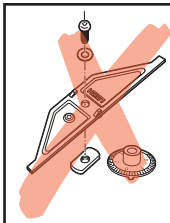

! Note: These parts are no longer required for setting up the F1 Template. They are not included with the Template package, and can be ignored if you already received them with your jig.

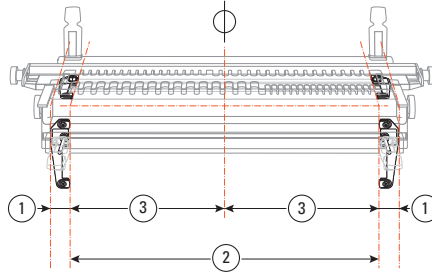

2 Ensure that the side stops are precisely 1½"[38mm] in from each end of the jig extrusions ①. This will position them 24½"[613mm] apart ② centred on the jig ③.

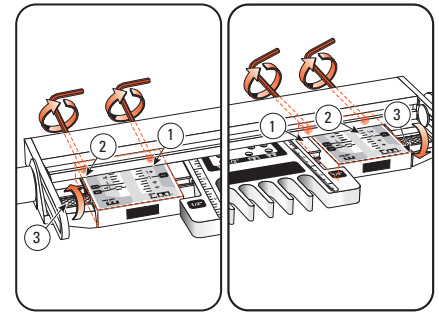

3 Loosen the two scale bar set screws ①, the two fence bracket screws ②, and the two scale thumb screws ③ at both ends of the template.

© Leigh Industries Ltd. All rights reserved. This pdf publication may be downloaded and stored on a computer and printed, viewed, and freely distributed for operational guidance and evaluation purposes. This document supplements the full User Guide publication for the Leigh tool and may refer to and depend on information in other parts of the tool's User Guide for completeness. Except as provided herein, no part of this document may be reproduced, sold, published or modified without the prior written permission of Leigh Industries Ltd. [Nov2005]

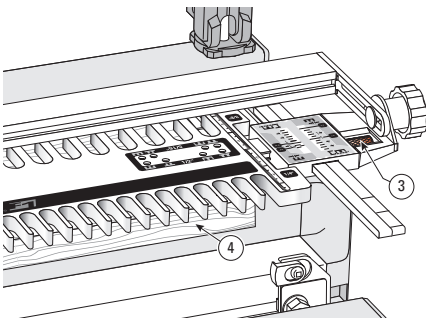

4 Slide the template assembly onto the jig support brackets with the ½" and ¼"[10 and 8mm] combs toward you and lower it gently onto the D4 jig's spacer board ④ (D4 UserGuide 1-1). Make sure the scale reading is the same on both scales, say on the 1"[25mm] mark, then tighten the thumb screws ③.

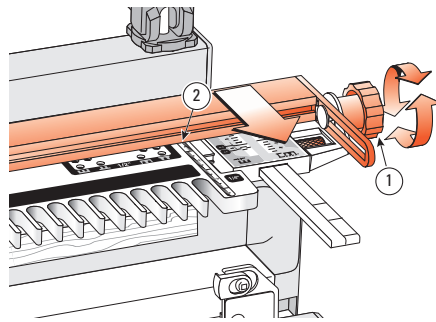

5 Loosen the fence knobs ① and move the fence on the template toward you as far forward as possible and with the fence scale reading the same at both ends ②. Then tighten the fence knobs ①.

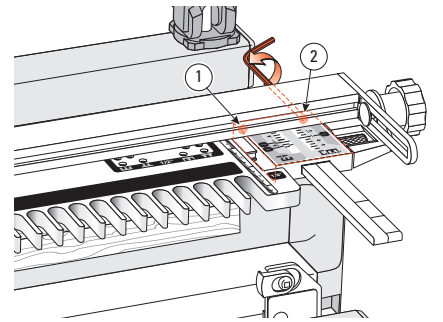

6 Tighten the scale bracket screws ②, but do not tighten the scale bar screws ① yet.

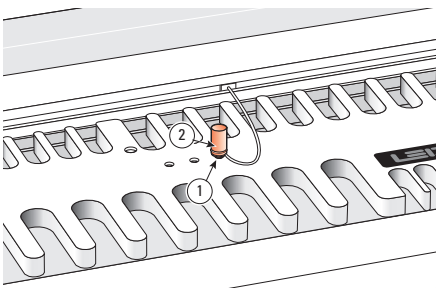

7 Discard the plastic shipping plug from the centre hole. Align the template so that the right hand hole ① of the three central template holes aligns with the hole in the bar. Insert the template pin ②, gently twisting and pushing the tapered pin into the hole until it is fully seated.

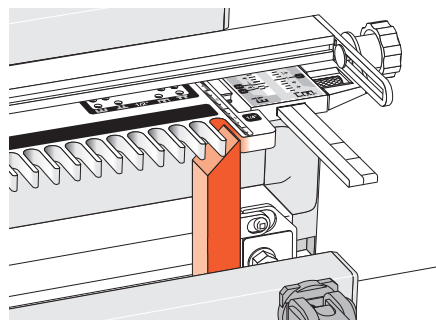

8 Trim off the end of an 8"[200mm] long perfectly straight block at about 30 degrees. Slide the combined bar/template to allow the block to protrude into the last socket of the ¼"[8mm] comb. Clamp the block with its vertical edge tight against the right hand side stop.

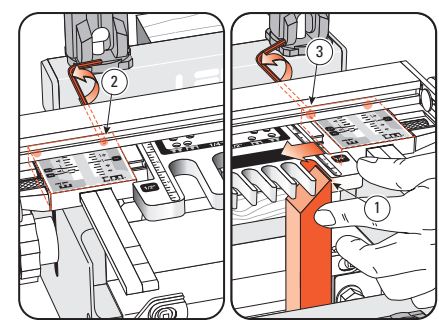

9 Move the combined template and bar to the left until the right side of the outer ¼"[8mm] opening touches the block ①. Taking care to not move the template assembly, tighten the scale screws at the left end ②. Remove the block. Remove the pin and slide the template left. Tighten the scale screw at the right end ③. Your Leigh F1 is now ready for use. ■