

D1600 CHAPTER 15

Hints and Tips

Here are some special techniques and ideas to help you get the most out of your Leigh D1600 Jig.

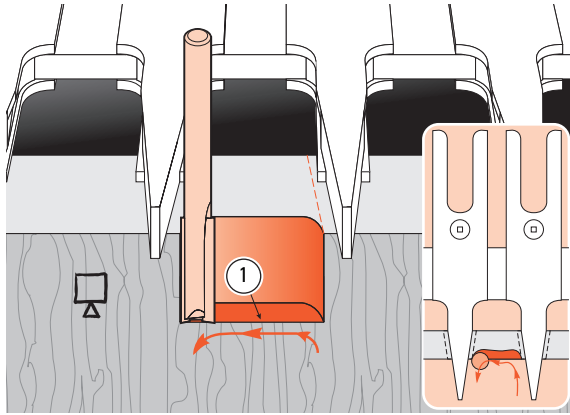

**15-1 Through Dovetail Pins**

With the straight cutter, carefully climb-rout from right to left. Make sure you control the router firmly when climb routing.

Climb routing produces a nice clean shoulder at ①.

Note: For clarity, the guidebush is not shown in this sequence.

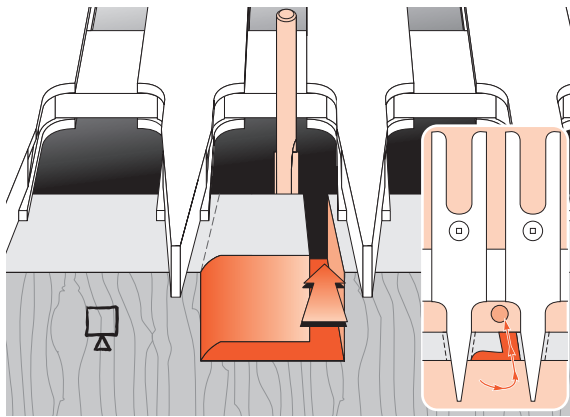
**15-2**

Rout through on the right side until the cutter is clear of the workpiece. Move the cutter to the left side and climb cut left to right.

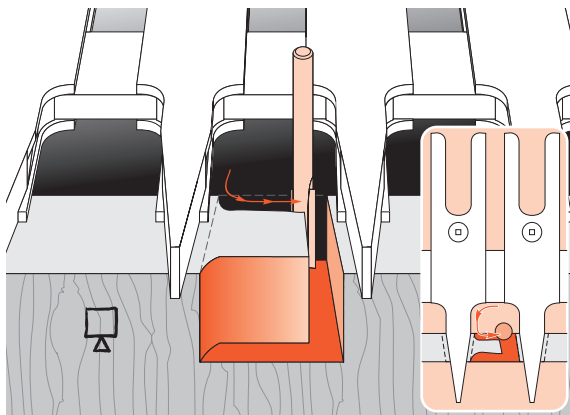
**15-3**

Climb rout from left to right from the rear of the cut. Take care to control router.

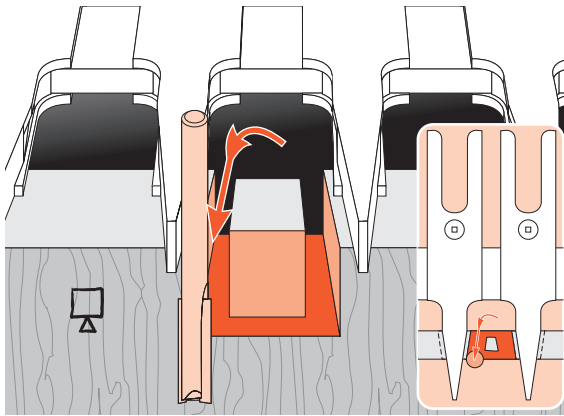
**15-4**

 Rout back through towards you on the left side.

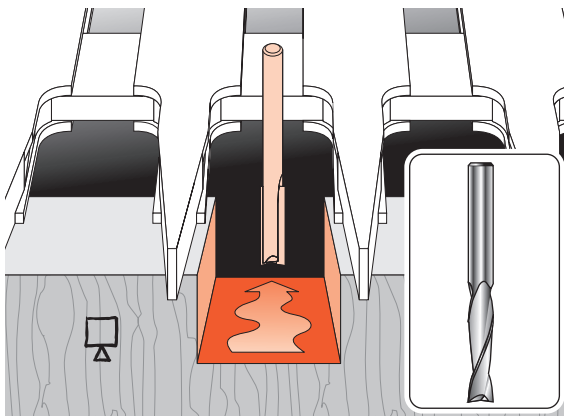
**15-5**

Rout away the rest of the waste.

Note: Spiral up-cut straight cutters (inset) generally rout more smoothly than the two-flute carbide-tipped bits.

If you want to try them, you should be aware that while the high-speed steel bits take a better edge, they are much less durable than the more costly solid carbide type.

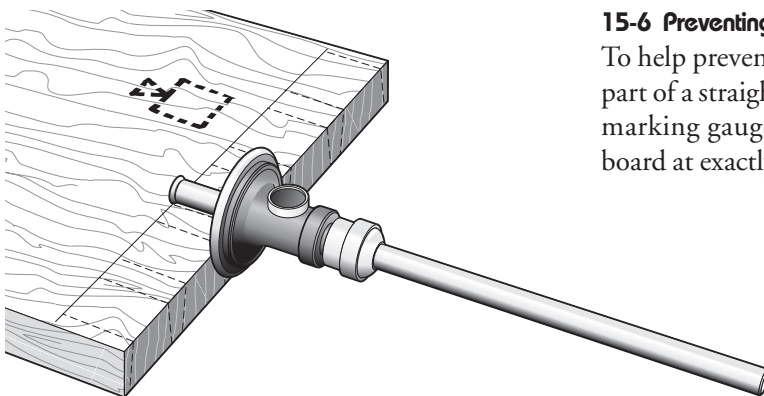
**15-6 Preventing TD Pins Tearout**

To help prevent tearout at the back bottom part of a straight cut, scribe a line with your marking gauge across the back of the pin board at exactly the depth of cut.

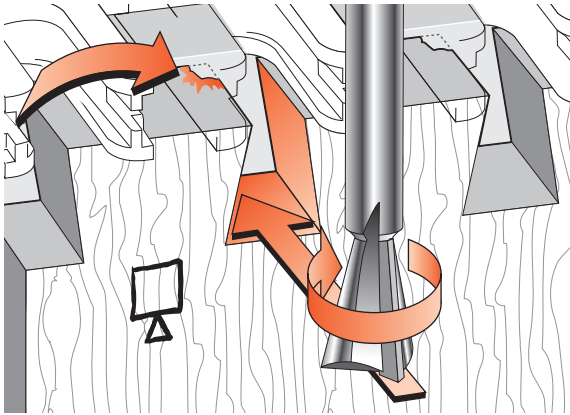
**15-7 Dovetail Tails Tearout**

With the dovetail cutter, most tearout occurs at the top left exit of the cut.

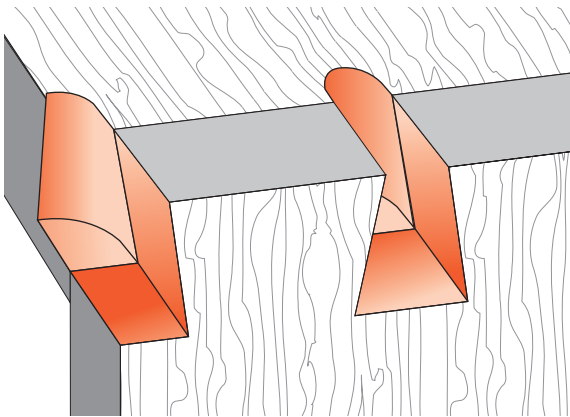
**15-8**

To help prevent this, back up the cut with the end-grain of a horizontal board pushed against the back of the workpiece and held in the rear clamp. This board replaces the spacer board.

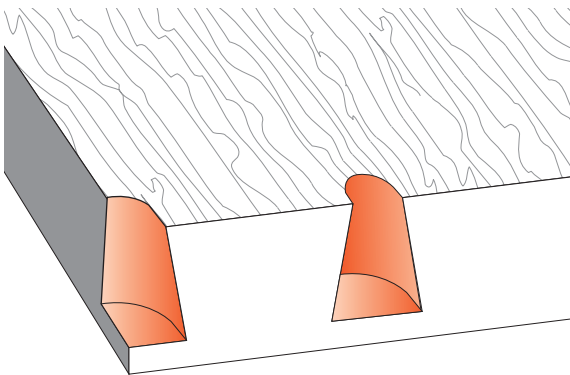
**15-9**

This same scrap piece can remain in place for successive cuts.

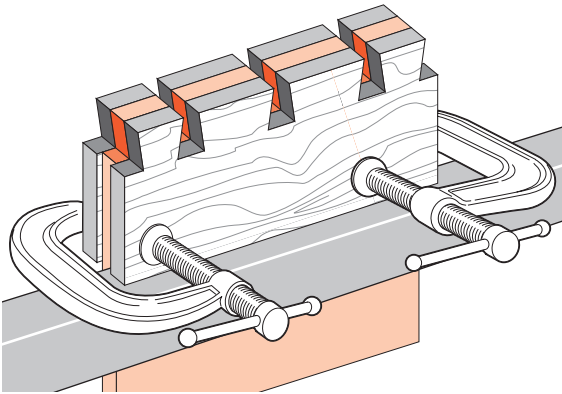

15-10

For particularly vulnerable pieces or that last piece of exotic wood, the best solution is to clamp horizontal scrap pieces to the front and back of the work piece. **Make sure the clamps are below the cutter depth.**

⚠️ PLYWOOD

Plywood is not a suitable material for routing; the laminates are very prone to tearout. Either of these two procedures (15-10 or 15-11) are essential for plywood but provide no guarantee of success.

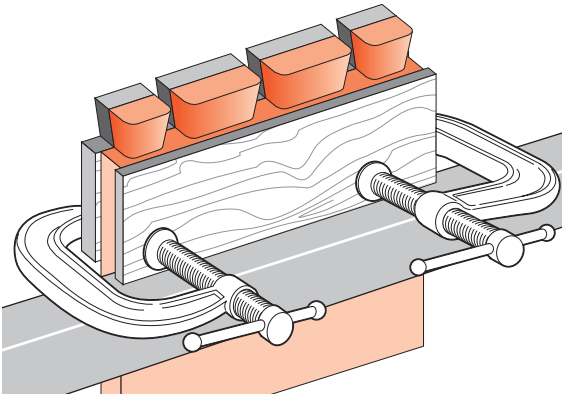

15-11

A single scrap piece can be C-clamped on the back of half-blind tails, *but make sure you protect the workpiece from the clamp pads.*

Note: There is no 100% solution to tearout. It's not the jig's fault, just something that happens when machining, sawing and even chiseling wood. Important pieces fall off from where you least want them to.

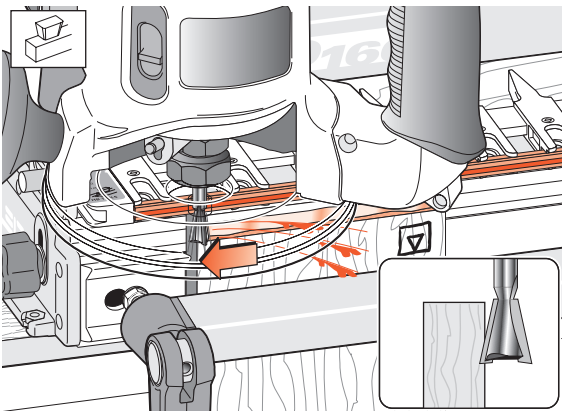

15-12

On face cuts, whether using a straight cutter or a dovetail cutter, climb routing or back routing will leave a clean edge; **but great caution must be exercised in controlling the router's movement from right to left, as the cutter rotation pulls the router in that direction anyway.**

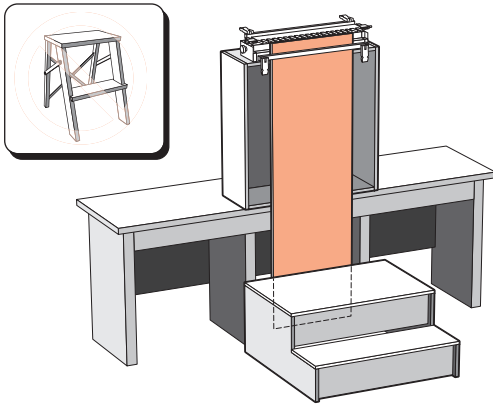
**15-13 General Hints**

For routing long vertical boards it may be necessary to build a jig stand to mount securely on your bench. Make the stand and bench height combination sufficient to accept the board length you have in mind. *The jig stand should be bolted securely to the bench.* Make up a stable platform to stand on as in the illustration. **Do not use a set of steps. Steps are not stable enough.**

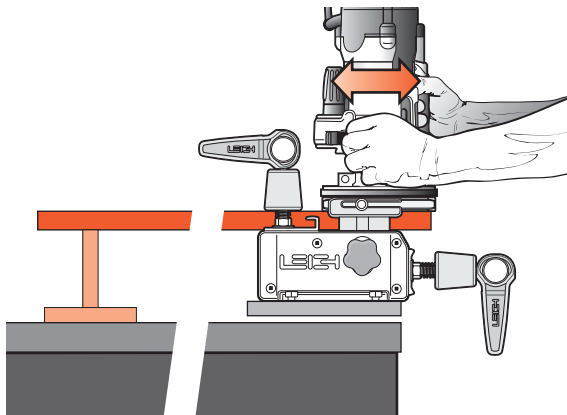
**15-14**

When placing long horizontal boards in the rear clamp, make sure the rear end of the board is supported to prevent unnecessary racking of the jig.

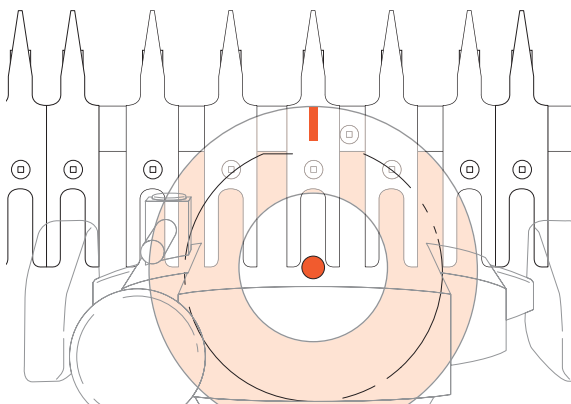
**15-15 Using The Router**

Mark the router base top edge at the 12 o'clock position with a felt marker pen. Without wood or cutters, try some **dry runs** in each jig mode. This will soon get you used to positioning the guidebush against the correct guide surface without looking under the router.

 **Do not rout at face level.**

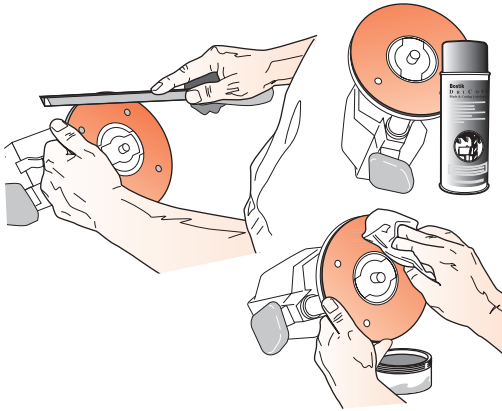
**15-16**

Some router bases have sharp edges on the outside and inside corners. A slight chamfer of the edges with a fine file or sandpaper block will ease router movement on the jig.

An occasional light spray of TopCote® or application of soft wax to the router base makes for smooth, easy router movement on the jig. ■

